

**NOTE:** Boom and jib geometry shown are for unloaded condition and machine standing level on firm supporting surface. Boom deflection and subsequent radius and boom angle change must be accounted for when applying load to hook.

# RATED LIFTING CAPACITIES (IN POUNDS)

A → B	ON OUTRIGGERS FULLY EXTENDED 360° ROTATION							ON OUTRIGGERS MID. EXTENDED 21' 11-3/4" (6.7m) SPREAD 360° ROTATION						
	36.1' (11m)	49' (14.94m)	61.7' (18.8m)	81' (24.69m)	100' (30.48m)	119' (36.27m)	138.5' (42.2m)	36.1' (11m)	49' (14.94m)	61.7' (18.8m)	81' (24.69m)	100' (30.48m)	119' (36.27m)	138.5' (42.2m)
10'	130,000	91,000	78,100					130,000	91,000	78,100				
12'	114,000	91,000	78,100					114,000	91,000	78,100				
15'	95,200	91,000	71,300	31,200				95,200	91,000	71,300	31,200			
20'	73,300	72,800	60,400	31,200	31,000			73,300	72,800	60,400	31,200	31,000		
25'	58,600	58,100	52,800	31,200	31,000	25,100		56,300	53,700	52,200	31,200	31,000	25,100	
30'	33,500	45,500	43,900	31,200	31,000	25,100	17,500	33,500	38,100	36,200	31,200	31,000	25,100	17,500
35'		34,800	34,200	31,200	27,800	25,100	17,500		28,600	27,000	30,000	27,800	25,100	17,500
40'		26,800	26,500	27,600	24,200	22,100	17,500		22,000	20,600	23,200	24,200	22,100	17,500
45'			20,700	23,400	21,300	19,300	17,000		16,100	17,700	19,600	19,300	17,000	
50'			16,600	19,000	18,600	17,000	15,600		12,700	13,700	16,000	17,000	15,600	
55'			13,300	15,700	16,300	15,100	14,500		9,800	10,600	13,300	14,400	14,500	
60'				13,000	13,900	13,600	13,200			8,300	10,900	12,000	12,300	
65'				10,800	11,600	12,100	12,000			6,700	9,000	9,900	10,600	
70'				8,900	9,800	10,800	11,000			5,600	7,400	8,100	8,800	
75'				5,500	8,200	9,200	9,500			4,600	5,900	6,600	7,400	
80'					6,800	7,700	8,100				4,600	5,300	6,200	
85'					5,500	6,400	7,100					3,600	4,200	5,200
90'					4,500	5,500	6,000					2,700	3,300	4,200
95'						4,500	5,000						2,600	3,400
100'							3,700	4,200					2,000	2,600
105'								3,000	3,600					1,900
110'								2,500	3,000					
115'									2,400					
120'									1,900					
125'									1,500					
C				0°			20°			0°			25°	38°

A : Boom length in feet    B : Load radius in feet    C : Minimum boom angle (deg.) for indicated length (no load)

A → B	ON OUTRIGGERS MID. EXTENDED 18' 1/2" (5.5m) SPREAD 360° ROTATION						
	36.1' (11m)	49' (14.94m)	61.7' (18.8m)	81' (24.69m)	100' (30.48m)	119' (36.27m)	138.5' (42.2m)
10'	130,000	91,000	78,100				
12'	114,000	91,000	78,100				
15'	95,200	91,000	71,300	31,200			
20'	60,700	60,000	57,700	31,200	31,000		
25'	41,000	39,900	38,900	31,200	31,000	25,100	
30'	28,700	28,200	27,600	30,000	30,000	25,100	17,500
35'		20,900	20,300	22,800	23,100	24,200	17,500
40'		16,200	14,900	17,700	18,500	19,500	17,500
45'			11,200	13,800	15,000	15,800	16,500
50'			8,400	10,700	12,000	12,600	13,400
55'			6,200	8,200	9,500	10,200	11,000
60'				6,200	7,400	8,300	9,000
65'				4,600	5,700	6,700	7,400
70'				3,400	4,300	5,300	6,000
75'				2,300	3,200	4,100	4,800
80'					2,400	3,100	3,700
85'					1,600	2,200	2,800
90'						1,400	2,100
95'							1,500
100'							
105'							
110'							
115'							
120'							
125'							
C				0°	26°	38°	45°

Boom length in feet

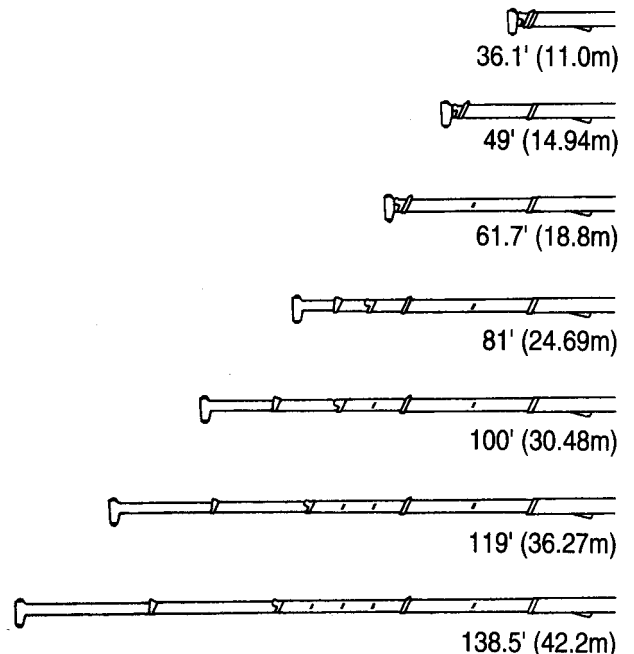

## RATED LIFTING CAPACITIES (IN POUNDS)

Boom Angle in Degree	ON OUTRIGGERS FULLY EXTENDED 360° ROTATION								ON OUTRIGGERS MID. EXTENDED 21' 11-3/4" (6.7m) SPREAD 360° ROTATION							
	Boom Length in Feet								Boom Length in Feet							
	138.5' (42.2m) Boom + 32.2' (9.8m) Jib				138.5' (42.2m) Boom + 56.1' (17.1m) Jib				138.5' (42.2m) Boom + 32.2' (9.8m) Jib				138.5' (42.2m) Boom + 56.1' (17.1m) Jib			
	5° offset		30° offset		5° offset		30° offset		5° offset		30° offset		5° offset		30° offset	
R	W	R	W	R	W	R	W	R	W	R	W	R	W	R	W	
80°	29.0	6,800	41.8	6,100	36.6	4,500	57.6	2,400	29.0	6,800	41.8	6,100	36.6	4,500	57.6	2,400
75°	44.9	6,800	56.7	5,200	54.3	4,500	74.4	2,200	44.9	6,800	56.7	5,200	54.3	4,500	74.4	2,200
70°	60.0	6,800	70.8	4,500	71.4	4,100	90.0	1,900	60.0	6,800	70.8	4,500	71.4	4,100	90.0	1,900
65°	74.0	5,600	84.0	3,800	87.3	3,300	105.0	1,800	74.0	5,600	84.0	3,800	87.3	3,300	105.0	1,800
60°	87.4	4,300	96.5	3,200	102.0	2,600	119.0	1,700	87.4	4,300	96.5	3,200	102.0	2,600	119.0	1,700
55°	99.5	3,000	108.0	2,600	117.0	2,200	131.0	1,500	99.2	2,700	108.0	2,000	116.0	1,700	131.0	1,300
50°	111.0	2,000	119.0	1,800	130.0	1,500	142.0	1,200	111.0	1,300						
45°	122.0	1,100	128.0	1,100												

R : Load radius in feet    W : Rated lifting capacity in pounds

Boom Angle in Degree	ON OUTRIGGERS MID. EXTENDED 18' 1/2" (5.5m) SPREAD 360° ROTATION							
	Boom Length in Feet							
	138.5' (42.2m) Boom + 32.2' (9.8m) Jib				138.5' (42.2m) Boom + 56.1' (17.1m) Jib			
	5° offset		30° offset		5° offset		30° offset	
R	W	R	W	R	W	R	W	
80°	29.0	6,800	41.8	6,100	36.6	4,500	57.6	2,400
75°	44.9	6,800	56.7	5,200	54.3	4,500	74.4	2,200
70°	60.0	6,800	70.8	4,500	71.4	4,100	90.0	1,900
65°	73.7	4,600	84.0	3,700	87.3	3,300	105.0	1,800
60°	86.4	2,200	96.0	2,000	102.0	1,800	118.0	1,400
55°								
50°								
45°								

**NOTE:** Load radii for jib operation are given for reference with the boom fully extended to 138.5' (42.2m).

6,200lbs. (2,800kg) shall be subtracted from the rated lifting capacities of main boom, when jib is attached to main boom head.

Jib weight is 2,200lbs. (1,000kg).

Standard number of parts of line should be according to the following table.

Boom Length in Feet (meters)	36.1' (11.0)	36.1' to 61.7' (11.0 to 18.8)	61.7' to 138.5' (18.8 to 42.2)	Single top Jib
No. of parts of line	12	8	4	1

The lifting capacity data stored in the LOAD MOMENT INDICATOR (AML-L) is based on the standard number of parts of line listed in the chart.

# RATED LIFTING CAPACITIES (IN POUNDS)

ON RUBBER									
Load Radius in Feet	Stationary						Creep		
	Over Front			360° Rotation			Over Front		
	Boom Length in Feet			Boom Length in Feet			Boom Length in Feet		
	36.1' (11.0m)	61.7' (18.8m)	100' (30.48m)	36.1' (11.0m)	61.7' (18.8m)	100' (30.48m)	36.1' (11.0m)	61.7' (18.8m)	100' (30.48m)
10'	67,200			34,300			50,000		
12'	58,600			32,700			45,600		
15'	51,300			24,800			39,000		
20'	36,000			15,400			29,200		
25'	25,200	24,000		9,900	8,800		22,500	21,000	
30'	18,100	17,200		6,000	5,200		17,300	16,400	
35'		12,500			2,800	4,500		12,500	
40'		9,200	10,800			2,900		9,200	10,800
45'		6,800	8,500					6,800	8,500
50'		4,800	6,900					4,800	6,900
55'		3,200	5,300					3,200	5,300
60'			4,000						4,000
65'			2,900						2,900
70'			2,100						2,100
A		0°	41°	0°	47°	63°		0°	41°

A: Minimum boom angle (deg.) for indicated length (no load)

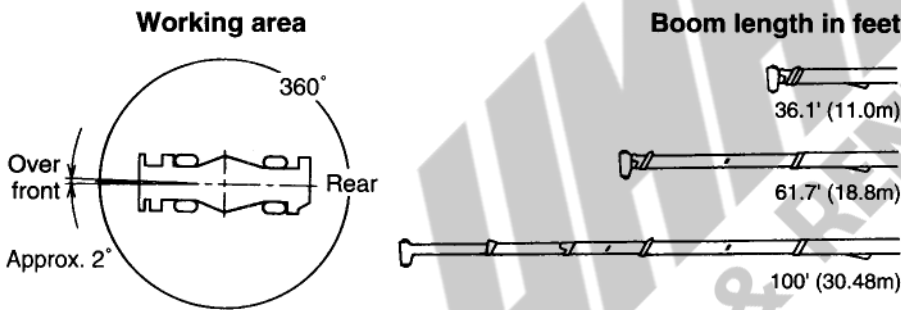

**NOTE :** Standard number of parts of line for on rubber operation should be according to the following table. The lifting capacity data stored in the LOAD MOMENT INDICATOR (AML-L) is based on the standard number of parts of line listed in the chart.

Boom Length in Feet (meters)	36.1' (11.0)	36.1' to 100' (11.0 to 30.48)	Single top
No. of parts of line	6	4	1

## WARNING AND OPERATING INSTRUCTIONS FOR ON RUBBER CAPACITIES

- Rated lifting capacities on rubber are in pounds and do not exceed 75 % of tipping loads as determined by SAE J765-Crane Stability Test Code.
- Rated lifting capacities shown in the chart are based on condition that crane is set on firm level surfaces with axle oscillation lockout applied. Those above bold lines are based on tire capacity and those below, on crane stability. They are based on actual load radius increased by tire deformation and boom deflection.
- If the axle oscillation lockout cylinders contain air, the axle will not be locked completely and rated lifting capacities may not be obtainable. Bleed the cylinders according to the operation, safety and maintenance manual.
- Rated lifting capacities are based on proper tire inflation, capacity and condition. Damaged tires are hazardous to safe operation of crane.
- Tires shall be inflated to correct air pressure.
- Over front operation shall be performed within two degrees in front of chassis.
- On rubber lifting with "jib" is not permitted. Maximum permissible boom length is 100ft. (30.48m).
- When making lift on rubber (stationary), set parking brake.
- For creep operation, boom must be centered over front of machine, swing lock engaged, and load restrained from swinging. Travel slowly and keep the lifted load as close to the ground as possible, and especially avoid any abrupt steering, accelerating or braking.
- Do not operate the crane while carrying the load.
- Creep is motion for crane not to travel more than 200ft. (60 m) in any 30 minute period and to travel at the speed of less than 1 mph (1.6km/h).
- For creep operation, set drive select switch to "4-WHEEL (Lo)" and set gear shift lever to "1".
- On rubber lifting operations are prohibited without full counterweight (16,800lbs.) installed.

Tires	Air Pressure
29.5-25-22PR	60 psi. (4.2kgf/cm <sup>2</sup> )

# WARNING AND OPERATING INSTRUCTIONS FOR LIFTING CAPACITIES

## GENERAL

1. RATED LIFTING CAPACITIES apply only to the machine as originally manufactured and normally equipped by TADANO LTD. Modifications to the machine or use of optional equipment other than that specified can result in a reduction of capacity.
2. Construction equipment can be hazardous if improperly operated or maintained. Operation and maintenance of this machine must be in compliance with information in the operation, safety and maintenance manual supplied with machine. If these manuals are missing, order replacement through the distributor.
3. The operator and other personnel associated with this machine shall fully acquaint themselves with the latest American National Standards Institute (ANSI) safety standards for cranes.

## SET UP

1. Rated lifting capacities on the chart are the maximum allowable crane capacities and are based on the machine standing level on firm supporting surface under ideal job conditions. Depending on the nature of the supporting surface, it may be necessary to have structural supports under the outrigger floats or tires to spread the loads to a larger bearing surface.
2. For outrigger operation, outriggers shall be properly extended with tires free of supporting surface before operating crane.

## OPERATION

1. Rated lifting capacities have been tested to and meet minimum requirements of SAE J1063-Cantilevered Boom Crane Structures Method of Test.
2. Rated lifting capacities do not exceed 85 % of the tipping load on outriggers fully extended as determined by SAE J765Crane Stability Test Code.  
Rated lifting capacities for partially extended outriggers are determined from the formula, Rated Lifting Capacities = (Tipping Load - 0.1 x Tip Reaction)/1.25.
3. Rated lifting capacities above bold lines in the chart are based on crane strength and those below, on its stability. They are based on actual load radius increased by boom deflection.
4. Rated lifting capacities include the mass of main hook block (1,320lbs. for 65 ton capacity), auxiliary hook block (330lbs. for 6.2 ton capacity), sling and auxiliary lifting devices and their masses shall be subtracted from the listed capacities to obtain the net load to be lifted.
5. Rated lifting capacities are based on freely suspended loads and make no allowance for such factors as the effect of wind, sudden stopping of loads, supporting surface conditions, inflation of tires, operating speeds, side loads, etc. Side pull on boom or jib is extremely dangerous.
6. Rated lifting capacities do not account for wind on lifted load or boom. Rated lifting capacities and boom length shall be appropriately reduced, when wind velocity is above 20 mph (9m/sec.).
7. Rated lifting capacities at load radius shall not be exceeded. Do not tip the crane to determine allowable loads.
8. Do not operate at boom lengths, radii, or boom angle, where no capacities are shown. Crane may overturn without any load on the hook.
9. When boom length is between values listed, refer to the rated lifting capacities of the next longer and next shorter booms for the same radius. The lesser of the two rated lifting capacities shall be used.
10. When making lifts at a load radius not shown, use the next longer radius to determine allowable capacity.

11. Load per line should not exceed 11,900lbs. (5,400kg) for main winch and 12,300lbs. (5,600kg) for auxiliary winch.
12. Check the actual number of parts of line with LOAD MOMENT INDICATOR (AML-L) before operation. Maximum lifting capacity is restricted by the number of parts of line of LOAD MOMENT INDICATOR (AML-L). Limited capacity is as determined from the formula, Single line pull for main winch (11,900lbs.) X number of parts of line.
13. The boom angle before loading should be greater to account for deflection.
14. The 36.1' (11.0m) boom length capacities are based on boom fully retracted. If not fully retracted [less than 49' (14.94m) boom length], use the rated lifting capacities for the 49' (14.94m) boom length.
15. Extension or retraction of the boom with loads may be attempted within the limits of the RATED LIFTING CAPACITIES. The ability to telescope loads is limited by hydraulic pressure, boom angle, boom length, crane maintenance, etc.
16. For lifting capacity of single top, reduce the rated lifting capacities of relevant boom by the mass of the main hook block. Capacities of single top shall not exceed 12,300lbs. (5,600kg) including main hook.
17. When erecting and stowing jib, be sure to retain it by hand or by other means to prevent its free movement.
18. 6,200lbs. (2,800kg) shall be subtracted from the rated lifting capacities of the main boom, when jib is attached to main boom head. Jib mass is 2,200lbs. (1,000kg).
19. Use Anti-two block (OVERWIND CUTOFF) disable switch when erecting and stowing jib and when stowing hook block. While the switch is pushed, the hoist does not stop, even when overwind condition occurs.
20. When lifting a load by using jib (aux. winch) and boom (main winch) simultaneously, do the following:
  - Enter the operation status as jib operation, not as boom operation.
  - Before starting operation, make sure that mass of load is within rated lifting capacity for jib.
21. Crane operation is prohibited without full counterweight (16,800lbs.) installed.  
Outriggers shall be extended a minimum of 21'11-3/4" (6.7m) spread when installing or removing removable counterweight.

## DEFINITIONS

1. Load Radius: Horizontal distance from a projection of the axis of rotation to supporting surface before loading to the center of the vertical hoist line or tackle with load applied.
2. Loaded Boom Angle: The angle between the boom base section and the horizontal, after lifting the rated lifting capacity at the load radius.
3. Working Area: Area measured in a circular arc about the centerline of rotation.
4. Freely Suspended Load: Load hanging free with no direct external force applied except by the hoist line.
5. Side Load: Horizontal side force applied to the lifted load either on the ground or in the air.

# WARNING AND OPERATING INSTRUCTIONS FOR USING THE LOAD MOMENT INDICATOR (AML-L)

## 1. When operating crane on outriggers:

- Set P.T.O. switch to "ON".
- Press the outrigger mode select key to register for the outrigger operation. The outrigger mode indicative symbol changes from flickering to lighting.
- Press the boom mode select key to register the boom mode. Each time the boom mode select key is pressed, the mode changes. Select the status that corresponds to the actual state of the boom.
- When erecting and stowing jib, select the status of jib set (jib state indicative symbol flicker).

## 2. When operating crane on rubber:

- Set P.T.O. switch to "ON".
- Press the on-tire mode select key. The outrigger mode indicative symbol will disappear as the on-tire mode indicative symbol comes on. Each time the on-tire mode select key is pressed, the mode changes. Select the creep operation, the on-tire mode indicative symbol flicker.
- Press the boom mode select key to register the boom mode.

However, pay attention to the following:

### (1) For stationary operation:

- The front capacities are attainable only when the over front position symbol comes on. When the boom is more than 2 degrees from centered over front of chassis, 360° capacities are in effect.

- When a load is lifted in the front position and then swung to the side area, make sure the value of the LOAD MOMENT INDICATOR (AML-L) is below the 360° lifting capacity.

### (2) For creep operation:

- The creep capacities are attainable only when boom is in the straight forward position of chassis and the over front position symbol is on. If boom is not in the straight forward position of chassis, never lift load.

3. A swing does not automatically stop even if the crane becomes overloaded.
4. During crane operation, make sure that the displays on front panel are in accordance with actual operating conditions.
5. The displayed values of LOAD MOMENT INDICATOR (AML) are based on freely suspended loads and make no allowance for such factors as the effect of wind, sudden stopping of loads, supporting surface conditions, inflation of tires, operating speed, side loads, etc. For safe operation, it is recommended when extending and lowering boom or swinging, lifting loads shall be appropriately reduced.
6. LOAD MOMENT INDICATOR (AML-L) is intended as an aid to the operator. Under no condition should it be relied upon to replace use of capacity charts and operating instructions. Sole reliance upon LOAD MOMENT INDICATOR (AML-L) aids in place of good operating practice can cause an accident. The operator must exercise caution to assure safety.

# HOISTING SPECIFICATIONS

## LINE SPEEDS AND PULLS

Layer	Speed	Main or auxiliary hoist – 15 3/4" (0.4) drum					
		Line Speeds (2)		Line pulls			
		F.P.M	m/min	Available (1)		Permissible (4)	
				Lbs.	kgf	Lbs.	kgf
1st	Low	180	55	15,698	7,121	14,272	6,474
	High	361	110				
2nd	Low	197	60	14,647	6,644	13,315	6,040
	High	394	120				
3rd	Low	213	65	13,520	6,133	12,292	5,576
	High	427	130				
4th	Low	230	70	12,557	5,696	11,417	5,179
	High	460	140				
5th	Low	246	75	11,721	5,317	10,657	4,834
	High	492	150				
6th (3)	Low	262	80	10,989	4,985	9,991	4,532
	High	525	160				

- (1) Developed by machinery with first layer of wire rope, but not based on rope strength or other limitation in machinery or equipment.
- (2) Line speeds based only on hook block, not loaded.
- (3) Sixth layer of wire rope is not recommended for hoisting operations.
- (4) Permissible line pull may be affected by wire rope strength.

## DRUM WIRE ROPE CAPACITIES

Wire Rope Layer	Main and auxiliary drum grooved lagging			
	3/4" (19 mm) wire rope			
	Rope per layer		Total wire rope	
	Feet	Meters	Feet	Meters
1	123.0	37.5	123.0	37.5
2	134.2	40.9	257.2	78.4
3	145.3	44.3	402.5	122.7
4	156.6	47.7	559.0	170.4
5	167.7	51.1	726.7	221.5
6	178.8	54.5	905.5	276.0

## DRUM DIMENSIONS

	Inch	mm
	Root Diameter	15-3/4"
Length	22-3/4"	578
Flange Diameter	25-3/8"	645

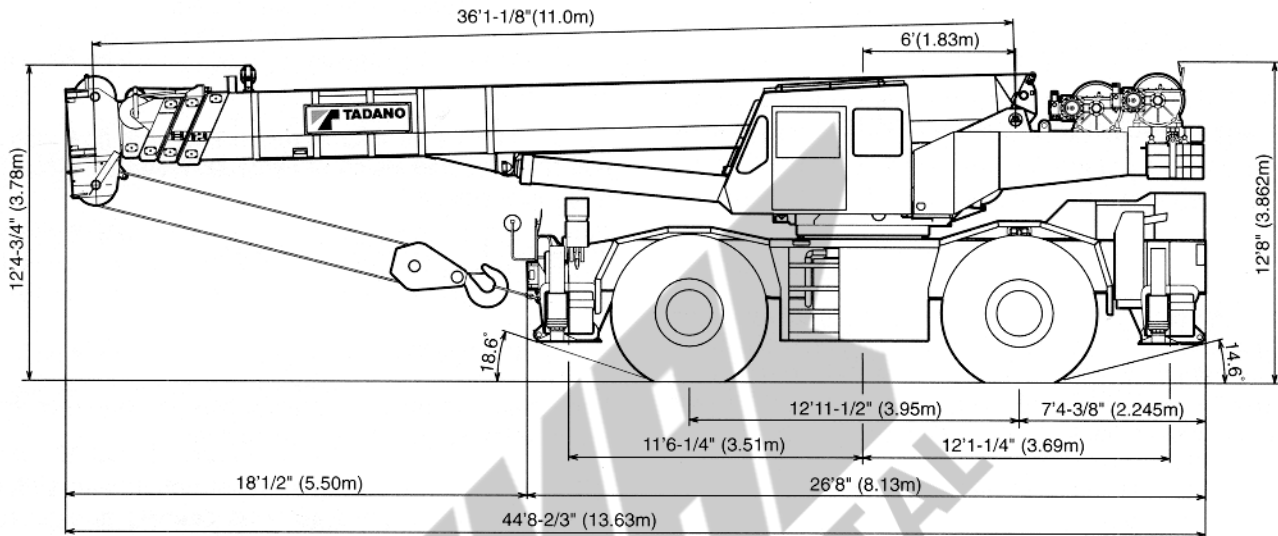

Note: Dimension is with boom angle at  $-1.5^\circ$ .

**GENERAL DIMENSIONS  
(29.5 X 25 Tires)**

	Feet	Meters
Turning Radius:		
4 wheel steer	21' 11-3/4"	6.7
2 wheel steer	39' 1/2"	11.9
Tail swing of counterweight	13' 6-1/4"	4.12

