

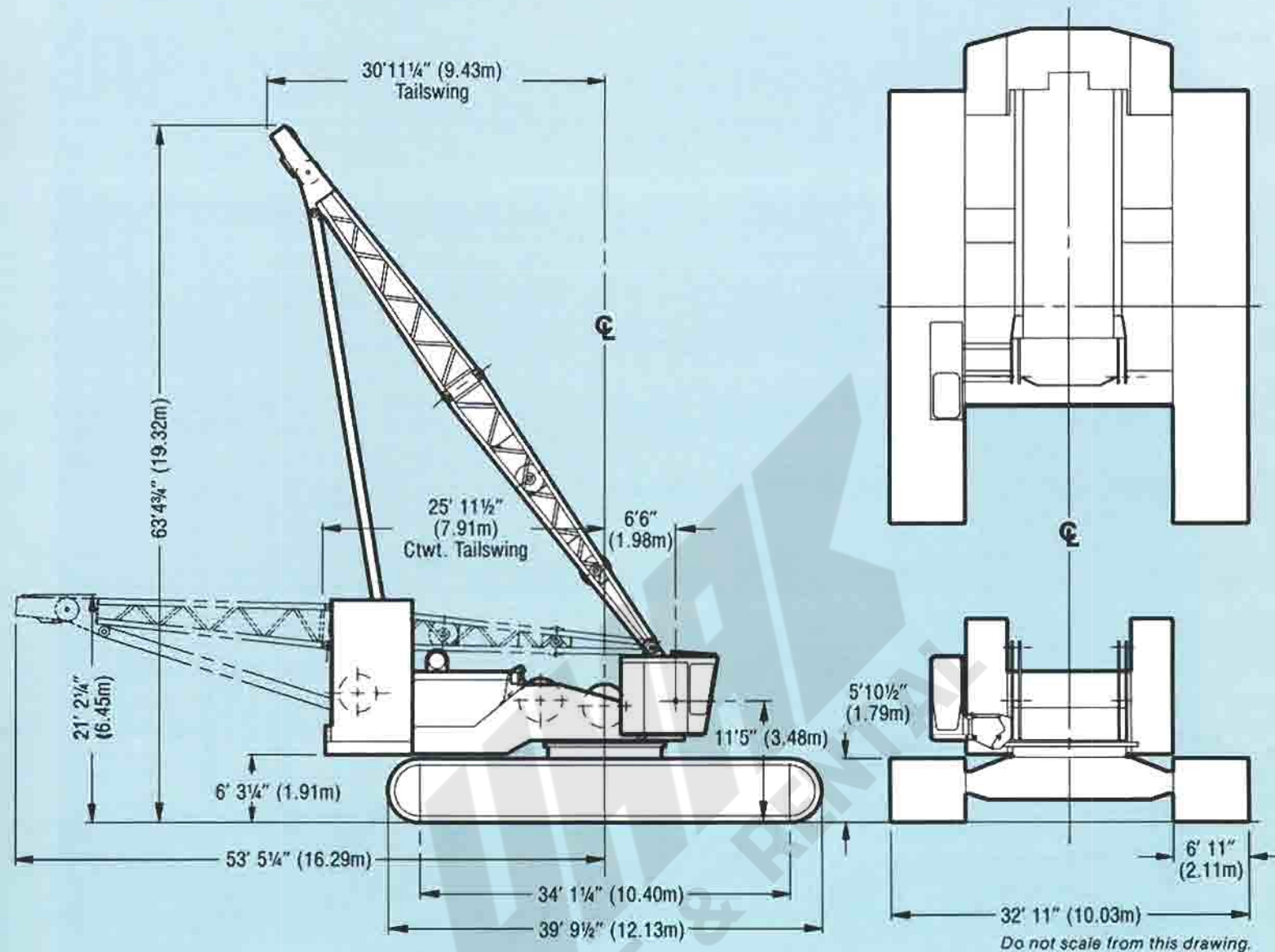

MODEL 6000 SERIES-2

600-TON CAPACITY • 375' MAXIMUM BOOM LENGTH

OUTLINE DIMENSIONS



WEIGHTS

	Pounds*		Pounds*
LIFTCRANE: With 75' No. 66 boom, gantry and backhitch, boom hoist rigging and pendants, wire rope, basic upperworks package, counterweights, 39'9½" long crawlers with 83" treads	1,020,000	REMOVABLE COUNTERWEIGHT: (Total).....	260,000
UPPERWORKS: Complete with basic machinery including main drums (but not including boom hoist, gantry, backhitch, front end attachments, operator's cab, or counterweights)	146,315	CARBODY MODULE: With king pin and roller path	63,670
BOOM: (75' Basic No. 66 — 600 Ton Rating)	35,020	TRANSVERSE BEAMS: (Each 37,725)	75,450
(100' Basic No. 66-64A — 400 Ton Rating)	29,900	POWER PACKAGE	11,900
GANTRY, BACKHITCH and BOOM HOIST	49,360	CRAWLER ASSEMBLIES: (2) with 83" wide crawler treads and hydraulic motors (each assembly 159,710)	319,420

*Weights are approximate and may vary between machines as a result of design changes and component variations.

UPPERWORKS

ROTATING BED: One-piece, deep section weldment with integral machinery side frames, fixture-bored to assure precision alignment. Provides rigid deck for power plant, house and hook rollers, rotating machinery and boom hinge.

POWER TRANSMISSION, VICON: The VICON® (Variable Independent CONTROL — patented) system provides an independent, stepless, variable-control power transmission for major machine functions. Engine power is divided at transmission case to hoist converter and hydraulic pumps which power swing and boom hoist.

HOIST DRIVE: Controlled torque converter powers hoist drums through chain drive to countershaft and then to main drum gears. Chain and gear drives enclosed and oil lubricated.

HYDRAULIC SWING: Reversible hydraulic motor driving through planetary gear reduction to swing shaft.

FRONT AND REAR DRUM ASSEMBLIES: Both drums have heat treated alloy steel drum shafts with antifriction bearing mountings. Drum gear hubs and clutch spiders are integral and keyed to drum shafts. Steel drums mounted on antifriction bearings have bolted cast iron combination brake and clutch flanges on each side. Air controlled, internal expanding, band-type drum clutches are mounted on left side and have heavy duty molded linings. Dual, air-actuated band-type brakes are spring set for parking and automatically set in the event of air pressure loss.

INDEPENDENT BOOM HOIST: Dual-drum, worm drive unit mounted on rear frame. Dual-drum design provides equalized pull on boom hoist rigging for optimum performance.

Independently powered by variable displacement hydraulic motor, providing full range speed control. Quick disconnect couplings on hydraulic lines facilitate removal. Bronze worm gear drives boom hoist drum shaft through a gear and pinion reduction. All rotating shafts antifriction bearing mounted. All gears fully enclosed and oil lubricated. Boom hoist brake is external contracting band type, spring applied, air released, located on worm shaft; automatically releases or sets as boom hoist is engaged or disengaged. Auxiliary brake, external contracting band type, set from operator's station. Ratchet mounted on boom hoist drum flange with pawl.

BOOM HOIST DRIVE: Powered through variable displacement hydraulic pump mounted to transmission case.

GANTRY AND BACKHITCH: Gantry and telescopic backhitch are heavy fabrication. Lattice gantry supported by rotating bed on large pins. Vertical sheaves antifriction bearing mounted. Equalizer sheaves bronze bearing mounted.

AUTOMATIC BOOM STOP: Automatic boom stop is provided to stop boom at desired maximum boom angle.

TELESCOPIC BOOM STOP: Starts cushioning at 79½° with positive physical stop at 85° from horizontal. Telescopic tube, air cushioned. Pinned to boom and frame.

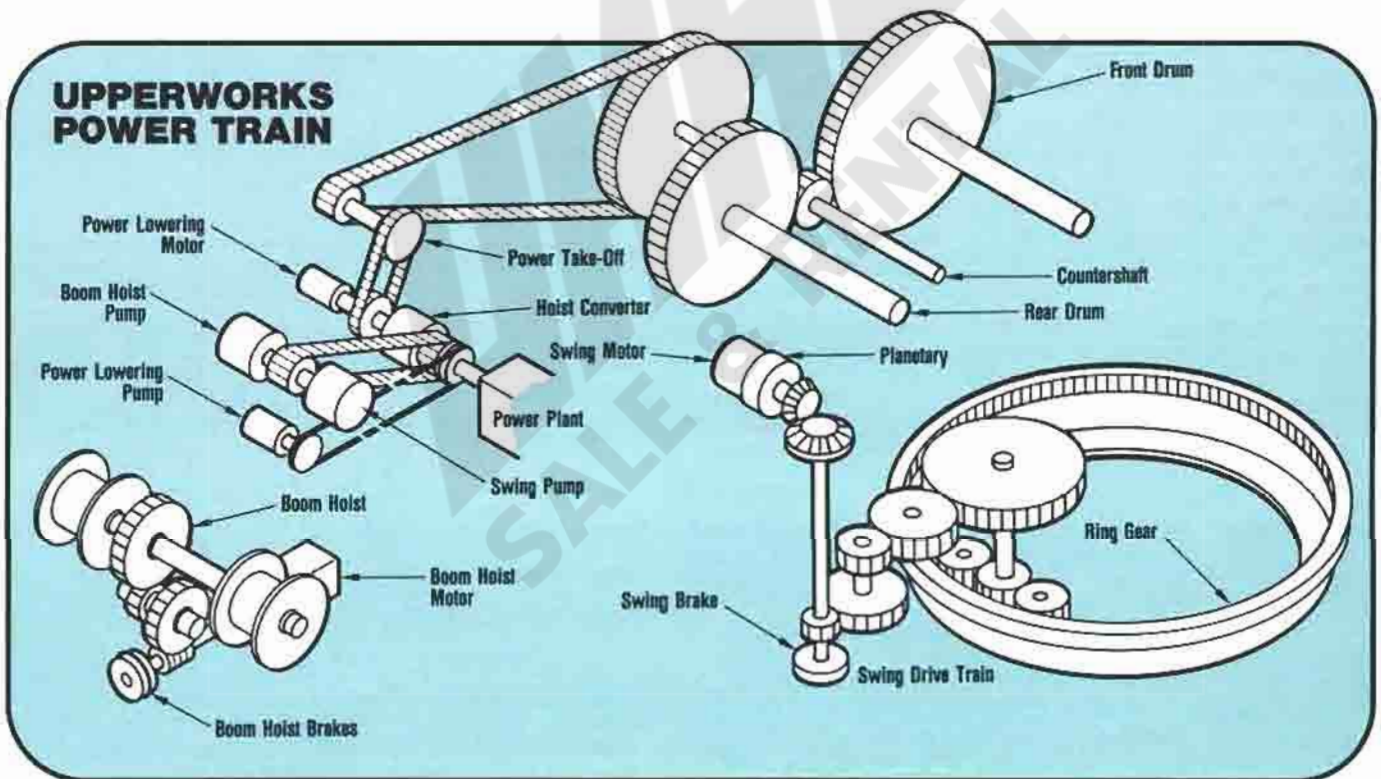

DRUM AND LAGGING CHART

Application		Drum	Dia.	Drum Width	Type	Wire Rope Size	Spooling Capacity Maximum
LIFTCRANE	Hoist	Front	28"	58"	Plain Drum	1½"	2665'
	Whip	Rear	28"	58"	Plain Drum	1½"	2665'

POWER PLANTS

	Model	Cylinder	Bore	Stroke	Cubic Inch Displacement	Net HP @ RPM (at flywheel)
Upper	Cummins KTA-1150-C600	6	6.25"	6.25"	1150	600 @ 2000
Lower	Cummins KT-1150-C450	6	6.25"	6.25"	1150	450 @ 2000

LOWERWORKS

CARBODY MODULE: A welded steel fabrication features heavy ribbed square box design with 11'2" diameter cast alloy steel ring gear and roller path with internal machine cut teeth. Roller path/ring gear and cast steel king pin bolted to carbody with high strength bolts.

TRANSVERSE BEAMS: Two welded steel fabricated transverse beams are assembled to carbody module with hook pins and hydraulically operated lock pins.

CRAWLER ASSEMBLY:

CRAWLER SIDE FRAMES, (2) welded steel fabrications with mounting for crawler tread drive tumbler at one end and crawler tread idler roller at the other. Intermediate rollers are mounted in lower sections between main vertical longitudinal plates. Transverse beam bearing pockets are located approximately 10' from each end and a fully enclosed travel gear housing, integral with the crawler side frame, is located between rear transverse beam pocket and drive tumbler mounting. Crawler frame is secured to the two transverse beams with two 4" diameter pins.

CRAWLER IDLER, cast steel with double flanges. Idler shaft is stationary and straddle-mounted.

INTERMEDIATE ROLLERS, cast steel 20" diameter double-flanged, straddle-mounted on shafts, with 16 rollers per crawler side frame.

CRAWLER GEAR AND TUMBLER, cast steel with self-cleaning design, straddle-mounted on stationary shaft with bronze bushings. Gear and tumbler transmit all power to crawler treads.

CRAWLER TREADS, 83" wide and constructed of cast alloy steel and closed box section design, with center driving lug. There are 60 treads per crawler and each tread is connected to the next with two high carbon steel pins.

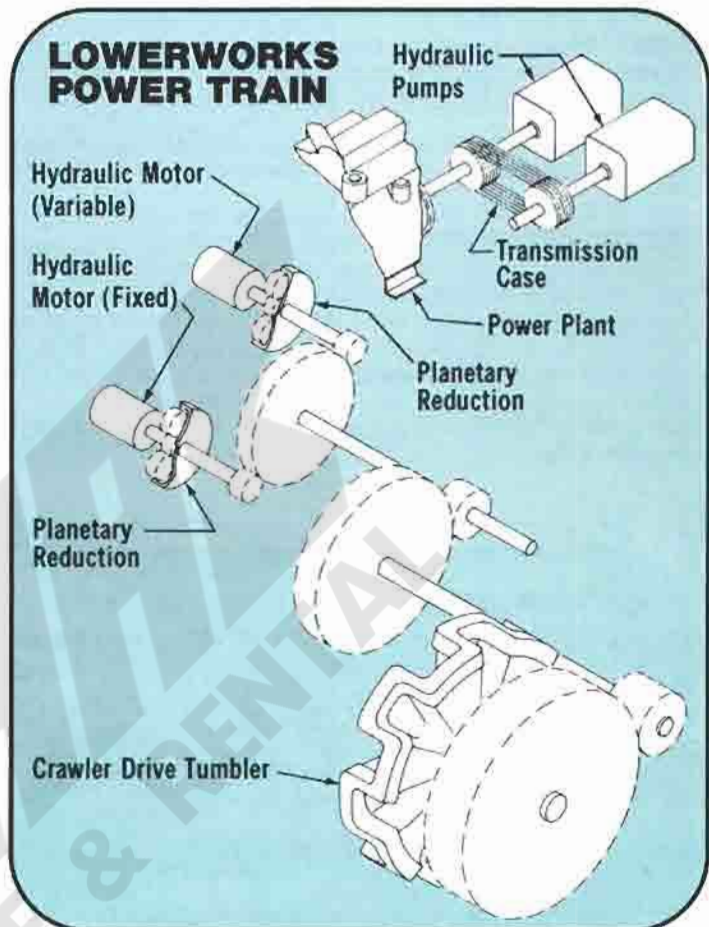

GENERAL

CONTROLS: Modulated air controls for main clutch functions. With VICON® system, main control levers are combination clutch and converter control. First 10° movement engages clutch; further movement increases converter output torque permitting variable speed control of hoist. Air actuated hydraulic valves operate boom hoist and travel functions. Air operated treadle-type drum brakes. Spring-set, air-released parking brake automatically set in the event of air pressure loss. Split control stand to provide exceptional downward visibility.

SWING SPEED: Variable, 2.4 RPM maximum.

TRAVEL SPEED: Variable, 1.0 MPH maximum.

OPERATOR'S MODULE: Isolated, fully enclosed, insulated steel module with safety glass windows. Mounted to right front corner of rotating bed. (Optional power actuated bracket permits raising, lowering or extending cab position to provide best operator visibility.) Cab swings forward of rotating bed for shipping clearance. Air signal horn and windshield wipers standard. Heater and air conditioner optional.

DISASSEMBLY AND SHIPPING: Both upperworks and lowerworks strip down, with minimum disassembly, to an 11' maximum shipping width, unmatched for crane's capacity.

Because of a program of continuing improvements, Manitowoc Engineering Co. reserves the right to change specifications at any time, without notice.

MANITOWOC ENGINEERING CO.

Division of The Manitowoc Company, Inc.
Manitowoc, Wisconsin 54221