

Manitowoc 12000

Product Guide



Features

- 110 t (120 USt) capacity
- 397 mton-m (2,880 ft-kips) maximum load moment
- 70,1 m (230 ft) heavy-lift boom
- 82,3 m (270 ft) fixed jib on heavy-lift boom
- 94,5 m (310 ft) luffing jib on heavy-lift boom
- 247 kW (332 HP) engine

Contents

| | |
|---------------------------------|----|
| Specifications | 3 |
| Outline dimensions | 6 |
| Transport data | 10 |
| Crane assembly | 11 |
| Performance data | 12 |
| Load chart notes | 13 |
| Boom combinations | 14 |
| Main boom range / load charts | 16 |
| Fixed jib range / load charts | 18 |
| Luffing jib range / load charts | 21 |
| Clamshell | 25 |
| Manitowoc Crane Care | 26 |

Specifications

Upperworks



Engine

Hino P11C-UN, 6 cylinder, water-cooled diesel, direct fuel injection with turbocharger, 247 kW (332 HP) at 2000 high-idle RPM. Maximum torque 1300 N•m (959 lb•ft) net at 1,500 rpm (SAE J 1349).

One diesel fuel tank, 400 liters (105 gallons) capacity.

Two 12 volt 136 AH capacity batteries, 24 volt system and 50 amp alternator.

All wiring harnesses and connectors are numbered for easier servicing. Machine is equipped with individual fused branch circuits.



Controls

Full-flow hydraulic control system for constant variable pressure to front and rear drums, boom hoist brakes and clutches. Controls respond instantly to the touch, delivering smooth function operation.

Relief valve pressures:

Load hoist, boom hoist

and propel system 315kg/cm2 (4,480 psi)

Swing system 280 kg/cm2, (3,980psi)

Control system 80 kg/cm2 (1,140 psi)



Hydraulic system

All four variable displacement piston-type pumps are driven by a heavy-duty pump drive. One of these pumps is used in the right propel circuit and hook hoist circuit, and can accommodate an optional third circuit. Another is used in the left propel circuit and hook hoist circuit. The third variable displacement pump is used in the boom hoist circuit. The fourth variable displacement pump is used in the swing circuit. In addition, two gear pumps are used in the control system and auxiliary equipment, and two gear pumps serve the brake cooling system.

Maximum pressure rating . . . 325 kg/cm2 (4,640 psi)

Load hoist, boom hoist and propel . . 2 Piston pumps

Boom Hoist 1 Piston pump

Swing 1 Piston pump

Control system and auxiliary 2 Gear pumps

Brake cooling system 2 Gear pumps

Reservoir capacity: 460 liter (121 US gallon).

Cooling: Oil-to-air heat exchanger (plate-fin type).

Filtration: Full-flow and bypass type with replaceable paper element.



Drums

Front and rear drums for load hoist powered by hydraulic variable displacement piston-type motors, driven through planetary reducers. Powered hoisting/lowering and free-fall operation is standard. Drum turn indicators for front and rear drums are also standard.

Brake & Clutches (compatible): Forced-circulation oil-cooled wet-type multi-disc brakes, each using positive and negative actuation. An external ratchet is fitted for locking the drums.

Drums: (front and rear) 613 mm (24.1") P.C.D. X 622 mm (24.5") wide drums, grooved for 26.0 mm wire rope.

Wire rope capacity:

Front drum 260 m (853 ft) working length

Rear drum 230 m (754 ft) working length

Storage length (each drum) 253 m (830')

Line speed: Single line on the first drum layer

Hoisting: 120m/min (394 ft/min)

Lowering: 120m/min (394 ft/min)

➤ **Optional third drum:** same dimensions and specifications as front and rear drums. Wire rope working length is 240 m (787').



Swing system

Swing unit: Powered by a hydraulic piston-type motor driving spur gears through planetary reducers, the swing system provides 360° rotation.

Swing brake: A spring-set, hydraulically released multiple-disc brake is internally fitted in swing motor.

Swing lock: 2 Position lock for transportation.

Rotating bed turntable: Single-row ball bearing with an integral internally cut swing gear.

Swing speed: 2.7 rpm



Boom support system

Single drum powered by a hydraulic axial piston motor through a planetary reducer.

Brake: A spring-set, hydraulically released multiple-disc brake is internally fitted in the boom hoist motor and

Specifications

operated through a counter-balance valve. An external ratchet is fitted for locking the drum.

Drum: Single drum, grooved for 20 mm dia. wire rope. Boom Hoist reeving is 10-part line.

Wire Rope Capacity:

Drum 155 m (508 ft) working length.

Line speed: Single line on the first drum layer

Hoisting: 48m/min (157 ft/min)

Lowering: 48m/min (157 ft/min)



Gantry

This high folding type gantry is fitted with a sheave frame for boom hoist reeving. It provides full up, full down positions.



Counterweight

| Qty. | Item | Unit weight | | Total weight | |
|----------------------------|-----------------|---------------|---------------|--------------|--------|
| | | kg | lb | kg | lb |
| 1 | Counterweight A | 10 000 | 22,050 | 10 000 | 22,050 |
| 2 | Counterweight B | 7 000 | 15,435 | 14 000 | 30,870 |
| 1 | Counterweight C | 10 000 | 22,050 | 10 000 | 22,050 |
| Counterweight Total | | 34 000 | 74,970 | | |



Operator's cab

Totally enclosed, full vision cab fitted with tinted safety glass. A fully adjustable, highbacked seat with arm rests permits operators to set their ideal working position. Side mounted console for auxiliary controls and instruments. An air conditioner, a signal horn, cigarette lighter, windshield wiper and inspection lamp socket are standard features.

Controls

In front of operator are the foot pedals for front, rear and third drum (option) brakes and foot throttle pedal. At operator's right side are the travel (propel) control levers and the function lock lever. To the operator's right front are the boom hoist control lever, front and rear winch control levers and the free-fall select switches for the front and rear winches and drum turn indicators (front/rear drum). To the operators left front are the swing control lever and third drum (option) control lever. To the operator's left are the crawler extend/retract lever and the positive swing lock. The left-hand console contains switches for the anti-two-block/boom overhoist. Directly in front of the console are the drum pawl lock for boom, front, rear and third drum (option) and the engine ignition key. The swing parking brake and signal horn are mounted on the swing control lever.

Gauges

Fuel gauge, engine water temperature gauge, hour meter and tachometer are located on the monitor display.

Warning display

All potential warnings, including battery charge, engine oil pressure, air cleaner, engine oil filter, control main pressure, and hydraulic oil temperature will appear on the monitor display when a fault occurs.

Safety device

Function lock lever, anti-two-block, boom over hoist limit switch, boom angle indicator, signal horn, boom hoist drum lock, front and rear drum lock, swing lock, swing alarm (buzzer and lamps), boom backstops and load moment indicator.

Lowerworks



Carbody

The durable carbody features steel welded construction with extendible axles.



Crawlers

Crawler assemblies can be hydraulically extended for wide-track operation or retracted for transportation. Crawler belt tension adjusted with hydraulic jack and maintained by shims between idler block and frame.

Crawler drive

The independent hydraulic propel drive is built into each crawler side frame. Each drive consists of a hydraulic motor driving a propel sprocket through a planetary gearbox. The hydraulic motor and gearbox are built into the crawler side frame within the shoe width. The track rollers are sealed for maintenance-free operation.

Crawler brakes

Spring set, hydraulically released, multiple disc-type parking brakes are built into each propel drive.

Steering mechanism

The hydraulic propel system provides both skid steering (driving one track only) and counter-rotating steering (driving each track in opposite direction) and differential track speed.

Crawler shoes

66 shoes per side, 914 mm (36") wide each crawler.

Travel speed

(High/Low) 1.4/1.0 km/h (0.87/0.62 mph)

Specifications

Attachments



Boom

Welded lattice construction using tubular, high-tensile steel chords with pin connections between sections. Boom tip is open throat construction. Two idler sheaves and four point sheaves are standard.

Basic boom length 15,24 m (50') consists of the boom butt section 7,62 m (25' 0") and boom top section 7,62 m (25' 0").

Optional boom inserts are available to provide extension capabilities. They also have welded lattice construction with tubular, high-tensile steel chords and pin connections on each one of 3,0 m (10'), 6,1 m (20'), 12,2 m (40') inserts.

Maximum total length of boom 70,1 m (230').



Fixed jib

The optional fixed jib employs welded lattice construction with tubular, high-tensile steel chords with pin connections between sections.

Basic jib length 9,14 m (30') consists of jib butt section 4,57 m (15') and jib top section 4,57 m (15').

Optional jib boom inserts of 3,0 m (10'), 6,1 m (20') are available for extension capabilities up to 21,3 m (70').

Maximum total length of boom and jib 61,0 m (200') + 21,3 m (70') is 82,3 m (270').



Luffing jib

Optional: Components to make up 18,3 m (60') basic luffing boom including 7,62 m (25') butt, 9,14 m (30') special luffing boom insert (with idler sheave), 1,5 m (5') top, boom strut assembly, jib strut assembly, jib stop assembly, strut backstops, backstay pendants with sheaves, mounting parts and LMI hardware.

Optional: 3,1 m (10'), 6,1 m (20'), and 12,2 m (40') luffing boom inserts. Utilize optional boom inserts to make up to 45,7 m (150') of luffing boom.

Optional: 18,3 m (60') basic luffing jib assembly including 5,8 m (19') luffing jib butt, 6,1 m (20') luffing jib insert, 6,4 m (21') luffing jib top, 6,4 m (21') front strut assembly, 5,3 m (17' 5") rear strut assembly, and luffing jib point roller assembly (single sheave) which is required during erection of the jib.

Maximum 51,8 m (170') jib length for 42,7 m (140') boom length and maximum 30,4 m (100') jib length for 45,7 m (150') boom length.

Note: Luffing boom utilizes the liftcrane boom inserts (except for the 30' special luffing boom insert). Also, the third drum and wire rope must be ordered with luffing jib attachment.

Tools and accessories

A set of tools and accessories are furnished.

Optional equipment

- Optional: Blocks and Hooks each with roller bearing sheaves grooved for 26.0 mm diameter wire rope, and roller bearing swivel with hook latch.
- 12 t ball hook, 456 kg wedge socket for 26 mm wire rope. (15 USt ball hook, 1,310 lb wedge socket for 26 mm wire rope.)
- 35 t hook block, 700 kg with one 622 mm Nominal O.D. roller bearing sheave. (40 USt hook block, 1,881 lb with one 24" Nominal O.D. roller bearing sheaves.)
- 70 t hook block, 900 kg, three 622 mm Nominal O.D. roller bearing sheave. (90 USt hook block, 4,060 lb, with three 24" Nominal O.D. roller bearing sheaves.)
- 110 t hook block, 1 700 kg, with five 622 mm Nominal O.D. roller bearing sheaves. (120 USt hook block, 3,760 lb with five 24" Nominal O.D. roller bearing sheaves.)
- Optional: Detachable upper boom point with one 575 mm (22.6") Nominal outer diameter roller bearing steel sheave grooved for 26mm rope for liftcrane.

Travel kit
Custom color

Working weight

Approximately 99,000 kg (218,000 lb) including upperworks and lowerworks, full upper counterweights and 15,2 m (50') basic boom.

Ground pressure

Approximately 92.9 kPa (13.5 psi) with basic boom and no load.

Gradeability

With basic boom: 30%.

Outline dimensions

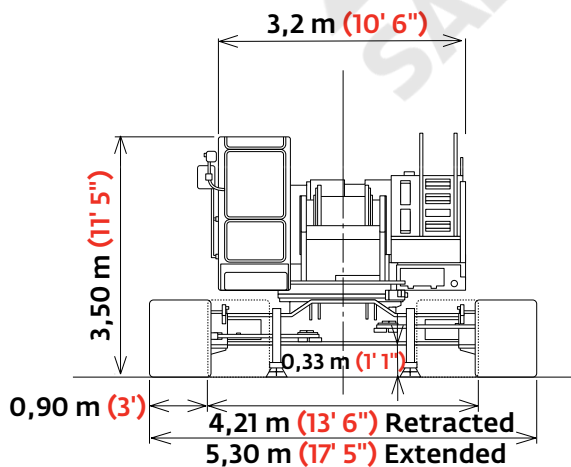
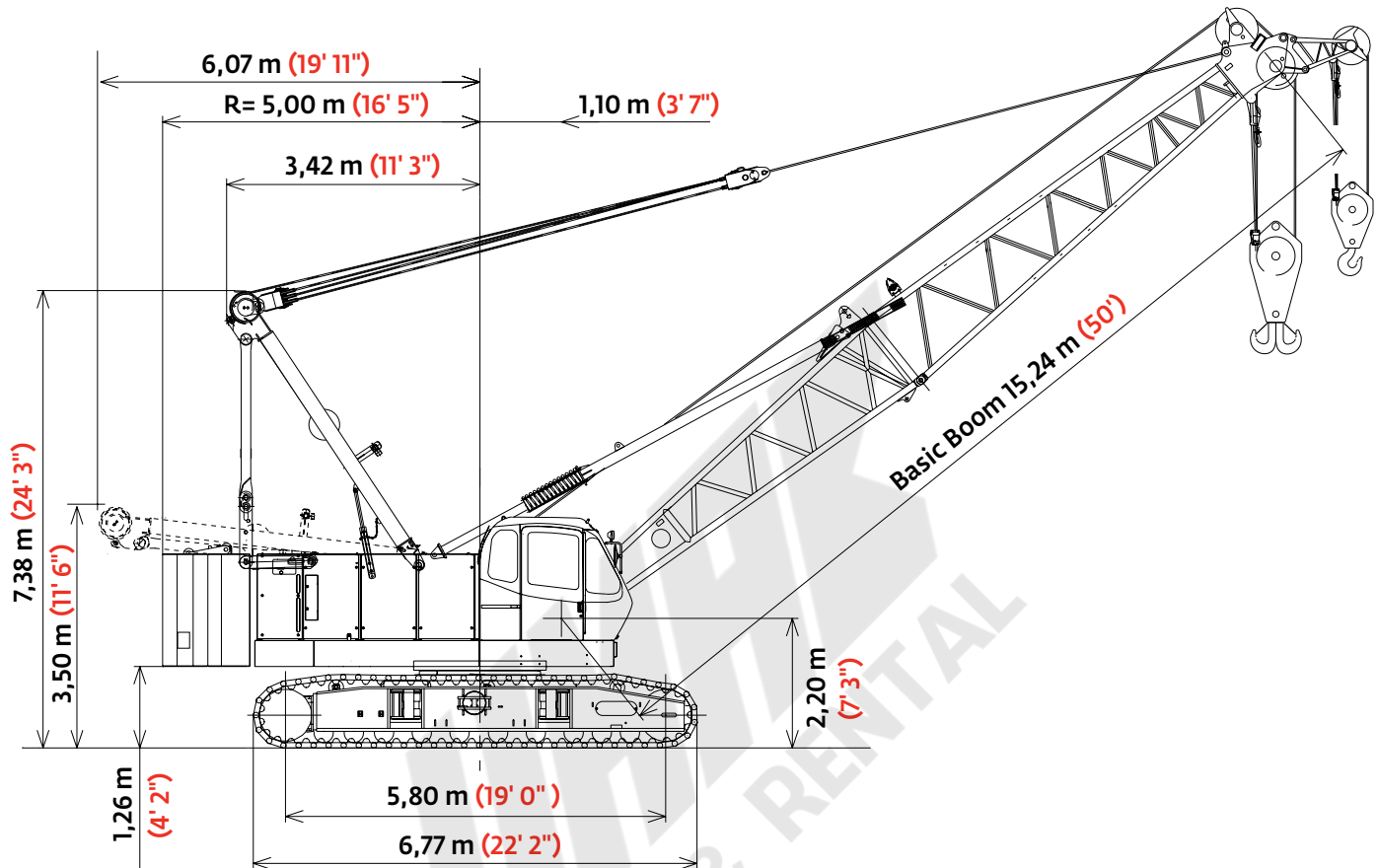

Outline dimensions

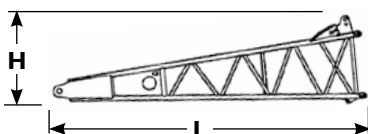
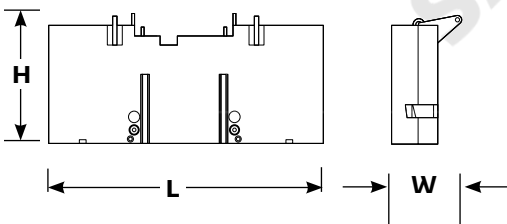
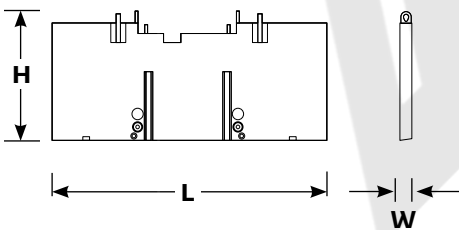
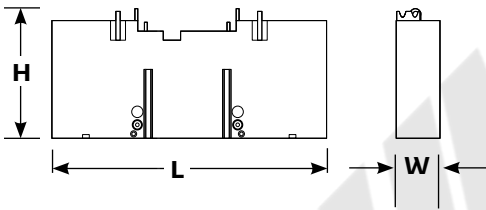
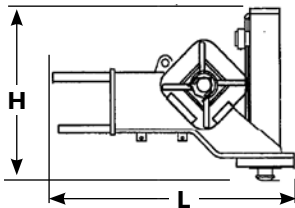
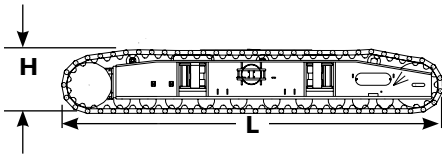
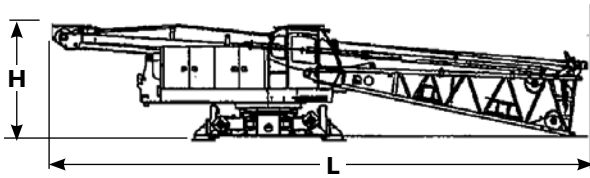

Upperworks without crawlers x1

| | | |
|--------|-----------|-----------|
| Length | 15,12 m | 49' 7" |
| Width | 3,24 m | 10' 8" |
| Height | 3,15 m | 10' 4" |
| Weight | 42 661 kg | 94,052 lb |

Note: Weight includes base machine, gantry, maximum hoist and whip lines on drums, boom butt, full hydraulic fluid reservoir, and one-third tank of fuel.

Crawlers x2

| | | |
|--------|-----------|-----------|
| Length | 6,77 m | 22' 3" |
| Width | 0,90 m | 3' 0" |
| Height | 1,15 m | 3' 9" |
| Weight | 11 830 kg | 26,085 lb |

Hydraulic jack (if removed) x4

| | | |
|--------|--------|--------|
| Length | 1,36 m | 4' 5" |
| Width | 0,32 m | 1' 1" |
| Height | 0,96 m | 3' 2" |
| Weight | 430 kg | 950 lb |

Upper counterweight A x1

| | | |
|--------|-----------|-----------|
| Length | 3,20 m | 10' 5" |
| Width | 0,58 m | 1' 11" |
| Height | 1,94 m | 6' 4" |
| Weight | 10 000 kg | 22,050 lb |

Upper counterweight B x2

| | | |
|--------|----------|-----------|
| Length | 3,20 m | 10' 5" |
| Width | 0,49 m | 1' 7" |
| Height | 1,92 m | 6' 3" |
| Weight | 7 000 kg | 15,435 lb |

Upper counterweight C x1

| | | |
|--------|-----------|-----------|
| Length | 3,20 m | 10' 5" |
| Width | 0,69 m | 2' 3" |
| Height | 1,92 m | 6' 3" |
| Weight | 10 000 kg | 22,050 lb |

Optional 3rd drum and wire rope x1

| | | |
|--------|----------|----------|
| Weight | 2 660 kg | 5,865 lb |
|--------|----------|----------|

Boom butt 7,6 m (25 ft) x1

| | | |
|--------|----------|----------|
| Length | 7,79 m | 26' 3" |
| Width | 1,68 m | 5' 6" |
| Height | 2,06 m | 6' 9" |
| Weight | 2 110 kg | 4,652 lb |

Option

Outline dimensions

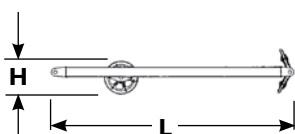
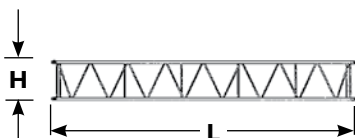
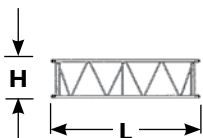
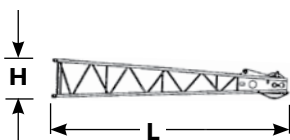
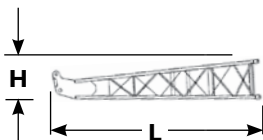
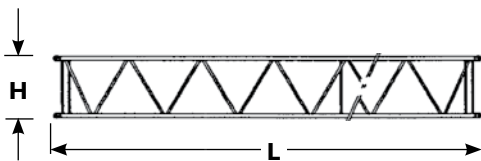
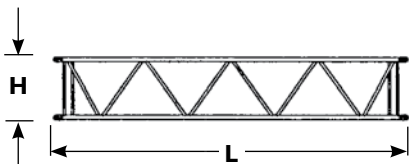
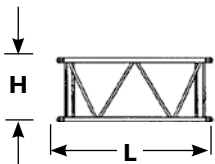
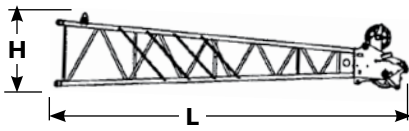

| Boom top 7,6 m (25 ft) | | x 1 |
|------------------------|----------|----------|
| Length | 8,32 m | 27' 4" |
| Width | 1,68 m | 5' 6" |
| Height | 1,69 m | 5' 7" |
| Weight | 1 525 kg | 3,362 lb |

| Boom insert 3,0 m (10 ft) | | x 1,2 |
|---------------------------|--------|--------|
| Length | 3,17 m | 10' 5" |
| Width | 1,68 m | 5' 6" |
| Height | 1,69 m | 5' 7" |
| Weight | 380 kg | 838 lb |

| Boom insert 6,1 m (20 ft) | | x 1,2 |
|---------------------------|--------|----------|
| Length | 6,22 m | 20' 5" |
| Width | 1,68 m | 5' 6" |
| Height | 1,69 m | 5' 7" |
| Weight | 655 kg | 1,445 lb |

| Boom insert 12,2 m (40 ft) | | x 1,2,3 |
|----------------------------|----------|----------|
| Length | 12,31 m | 40' 5" |
| Width | 1,68 m | 5' 6" |
| Height | 1,69 m | 5' 7" |
| Weight | 1 195 kg | 2,635 lb |

Note: Use of one "A" type insert with lug required for any boom combinations that require a 12,2 m (40') insert.

| Fixed jib butt | | x 1 |
|----------------|--------|--------|
| Length | 4,81 m | 15' 9" |
| Width | 0,80 m | 2' 8" |
| Height | 0,80 m | 2' 8" |
| Weight | 200 kg | 440 lb |

| Fixed jib top | | x 1 |
|---------------|--------|--------|
| Length | 4,91 m | 16' 1" |
| Width | 0,80 m | 2' 8" |
| Height | 0,80 m | 2' 8" |
| Weight | 280 kg | 617 lb |

| Fixed jib insert 3,0 m (10 ft) | | x 1,2 |
|--------------------------------|--------|--------|
| Length | 3,12 m | 10' 3" |
| Width | 0,80 m | 2' 8" |
| Height | 0,80 m | 2' 8" |
| Weight | 100 kg | 220 lb |

| Fixed jib insert 6,1 (20 ft) | | x 1,2 |
|------------------------------|--------|--------|
| Length | 6,16 m | 20' 3" |
| Width | 0,80 m | 2' 8" |
| Height | 0,80 m | 2' 8" |
| Weight | 180 kg | 395 lb |

| Fixed jib strut | | x 1 |
|-----------------|--------|---------|
| Length | 3,62 m | 11' 11" |
| Height | 0,62 m | 2' 0" |
| Weight | 250 kg | 550 lb |

Option

Outline dimensions

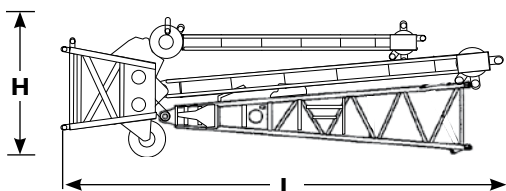
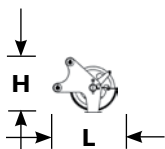
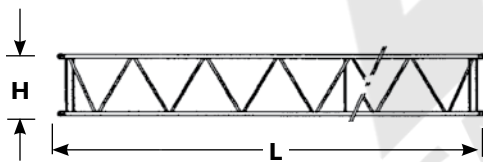
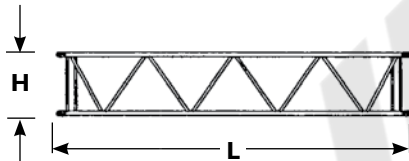
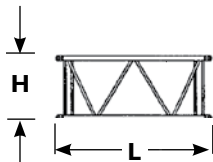
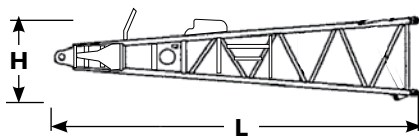
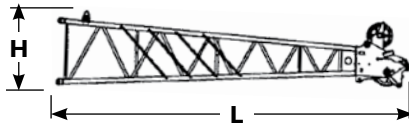
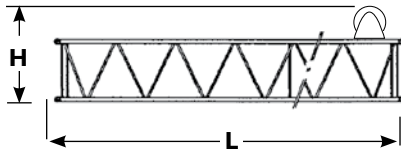

Special luffing boom insert
9,1 m (30 ft) x1

| | | |
|--------|---------|----------|
| Length | 9,27 m | 30' 5" |
| Width | 1,68 m | 5' 6" |
| Height | 2,41 m | 7' 11" |
| Weight | 1160 kg | 2,558 lb |

Luffing jib top x1

| | | |
|--------|---------|----------|
| Length | 6,91 m | 22' 8" |
| Width | 1,50 m | 4' 11" |
| Height | 1,48 m | 4' 10" |
| Weight | 1170 kg | 2,580 lb |

Luffing jib butt x1

| | | |
|--------|--------|----------|
| Length | 5,97 m | 19' 7" |
| Width | 1,49 m | 4' 11" |
| Height | 1,32 m | 4' 4" |
| Weight | 836 kg | 1,903 lb |

Luffing jib insert 3,0 m (10 ft) x1,2

| | | |
|--------|--------|--------|
| Length | 3,16 m | 10' 5" |
| Width | 1,49 m | 4' 11" |
| Height | 1,29 m | 4' 3" |
| Weight | 310 kg | 684 lb |

Luffing jib insert 6,1 m (20 ft) x1,2

| | | |
|--------|--------|----------|
| Length | 6,21 m | 20' 5" |
| Width | 1,49 m | 4' 11" |
| Height | 1,29 m | 4' 3" |
| Weight | 540 kg | 1,147 lb |

Luffing jib insert 12,2 m (40 ft) x1,2,3

| | | |
|--------|---------|----------|
| Length | 12,31 m | 40' 4" |
| Width | 1,49 m | 4' 11" |
| Height | 1,29 m | 4' 3" |
| Weight | 960 kg | 2,117 lb |

Luffing jib point roller assembly x1

| | | |
|--------|--------|--------|
| Length | 1,01 m | 3' 4" |
| Width | 0,89 m | 2' 11" |
| Height | 0,91 m | 3' 0" |
| Weight | 380 kg | 838 lb |

Luffing boom top assembly (Shipping style) x1

| | | |
|--------|----------|----------|
| Length | 8,19 m | 26' 10" |
| Height | 2,65 m | 8' 8" |
| Weight | 3 580 kg | 7,895 lb |

Transport data

Trailer load out summary

12000 fixed jib 21,3 m (70 ft) on 12000 boom 70,1 m (230 ft)

| Item | Weight each item kg (lb) | Quantity on trailer load # | | | | | |
|--|--------------------------------|-------------------------------|--------------------|--------------------|-------------------|--------------------|--------------------|
| | | 1 | 2 | 3 | 4 | 5 | 6 |
| 12000 basic crane with crawlers removed | 42 661 (94,052) | 1 | | | | | |
| Crawler frame | 11 832 (26,085) | | 1 | | | | |
| Crawler frame | 11 832 (26,085) | | | 1 | | | |
| Counterweight A | 10 000 (22,050) | | | | | 1 | |
| Counterweight B | 7 000 (15,435) | | | | 1 | | |
| Counterweight B | 7 000 (15,435) | | | | | 1 | |
| Counterweight C | 10 000 (22,050) | | | | | | 1 |
| 12,2 m (40 ft) boom insert, pendants | 1 195 (2,635) | | 1 | | | | |
| 12,2 m (40 ft) boom insert, pendants | 1 195 (2,635) | | | 1 | | | |
| 12,2 m (40 ft) boom insert, pendants | 1 195 (2,635) | | | | 1 | | |
| 6,1 m (20 ft) boom insert, pendants | 655 (1,445) | | | | | 1 | |
| 6,1 m (20 ft) boom insert, pendants | 655 (1,445) | | | | | | 1 |
| 3,0 m (10 ft) boom insert, pendants | 380 (838) | | 1 | | | | |
| 3,0 m (10 ft) boom insert, pendants | 380 (838) | | | | | 1 | |
| Standard boom top 7,6 m (25 ft) | 1,525 (3,362) | | | | | | 1 |
| Upper boom point | 501 (1,105) | | | 1 | | | |
| 4,6 m (15 ft) fixed jib top | 280 (617) | | | | 1 | | |
| 4,6 m (15 ft) fixed jib butt | 200 (440) | | | | | | 1 |
| 6,1 m (20 ft) fixed jib insert | 180 (395) | | | | 1 | | |
| 6,1 m (20 ft) fixed jib insert | 180 (395) | | | | | | 1 |
| Approximate total Shipping weight kg (lb) | | 42 661 (94,052) | 13 407 (29,558) | 13 528 (29,825) | 8 655 (19,082) | 18 035 (39,768) | 12 560 (27,692) |
| | | 1 | 2 | 3 | 4 | 5 | 6 |

Crane assembly

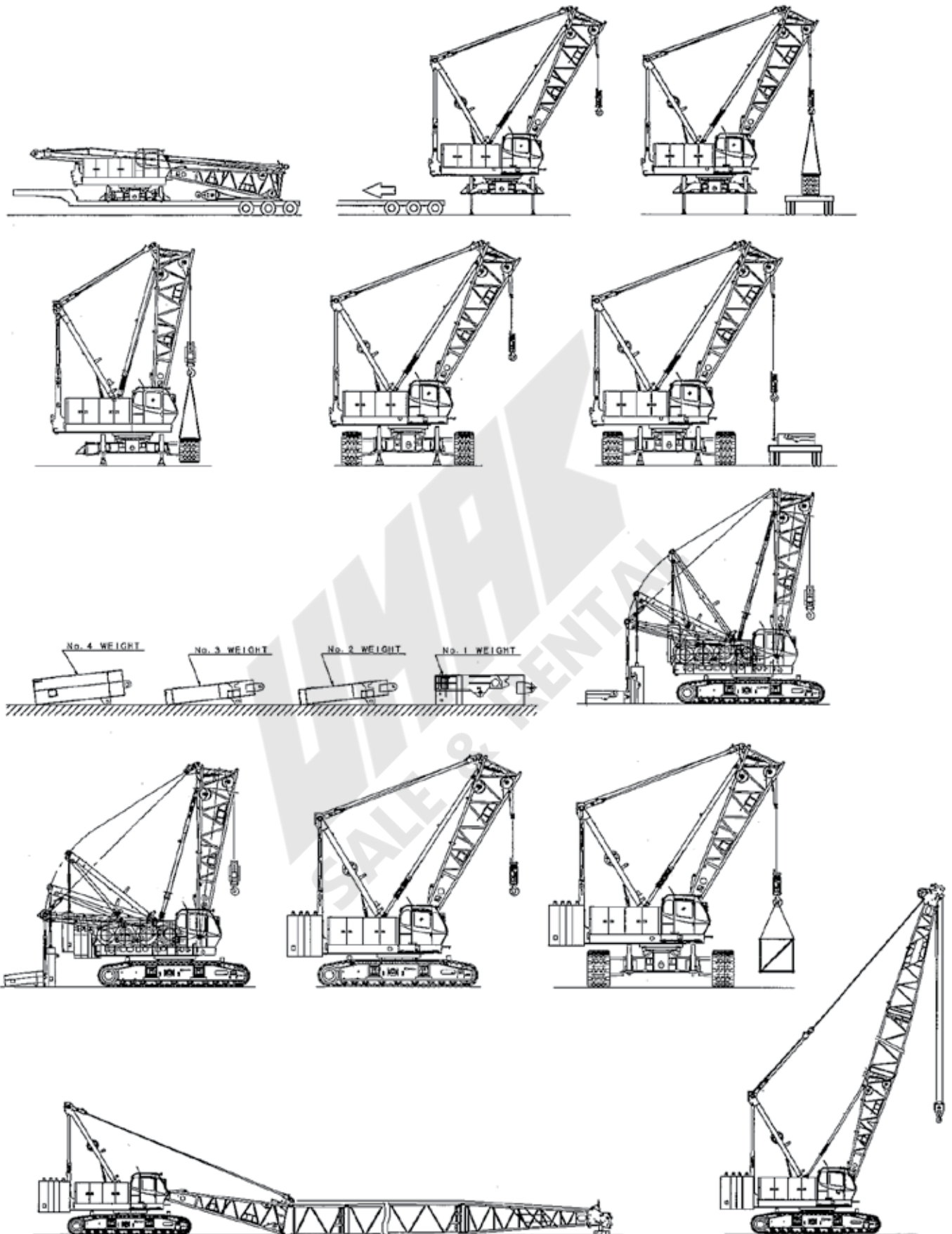

Performance data

| Line pull | | |
|-------------------|----------------------------|-------------------------------|
| | Rated line pull kg (lb) | *Maximum line pull kg (lb) |
| Front drum | 11 400 (25,100) | 21 180 (46,700) |
| Rear drum | 11 400 (25,100) | 21 180 (46,700) |
| Optional 3rd drum | 11 400 (25,100) | 21 180 (46,700) |

* Maximum line pull is not based on wire rope strength.

| Wire rope specifications | | | | |
|--------------------------|-------------------------|----------------|-----------------------------|---------------------------------|
| Use | Specs | Diameter mm | Working length m (ft) | Breaking strength kg (lb) |
| Front drum | IWRC 6 X Fi (29) C/O | 26,0 | 260 (853) | 54 431 (120,000) |
| Rear drum | IWRC 6 X Fi (29) C/O | 26,0 | 230 (754) | 54 431 (120,000) |
| Boom hoist drum | IWRC 6 X WS (31) C/O | 20,0 | 155 (508) | 33 430 (73,700) |

| Front and rear winch performance (optional: third winch) | | | | | | |
|--|------------------------------|--------------|--------------|--------------|--------------|--------------|
| Layer | Line speed m/min (ft/min) | | | | | |
| | 1 | 2 | 3 | 4 | 5 | 6 |
| Single line pull kg (lb) | | | | | | |
| 0 (0) | 120 (394) | 129 (422) | 137 (450) | 146 (479) | 155 (505) | 163 (535) |
| 2 268 (5,000) | 118 (387) | 126 (415) | 135 (443) | 143 (471) | 152 (499) | 160 (526) |
| 4 536 (10,000) | 108 (353) | 108 (353) | 108 (353) | 108 (353) | 108 (353) | 108 (353) |
| 6 804 (15,000) | 72 (235) | 72 (235) | 72 (235) | 72 (235) | 72 (235) | 72 (235) |
| 9 072 (20,000) | 52 (117) | 52 (117) | 52 (117) | 52 (117) | 52 (117) | 52 (117) |
| 11 340 (25,000) | 43 (141) | 43 (141) | 43 (141) | 43 (141) | 43 (141) | 43 (141) |
| 13 608 (30,000) | 36 (118) | 36 (118) | 36 (119) | 37 (121) | 37 (122) | 37 (123) |
| 15 876 (35,000) | 31 (103) | 32 (104) | 32 (105) | 32 (105) | – | – |
| 18 144 (40,000) | 28 (92) | 28 (92) | – | – | – | – |

NOTE: Line speeds and line pull based on single line.
Line pulls are not based on wire rope strength.

Load chart notes

- Rated loads included in the charts are the maximum allowable freely suspended loads at a given boom length, boom angle and load radius, and have been determined for the machine standing level on firm supporting surface under ideal operating conditions. The user must limit or de-rate rated loads to allow for adverse conditions (such as soft or uneven ground, out-of-level conditions, wind, side loads, pendulum action, jerking or sudden stopping of loads, inexperience of personnel, multiple machine lifts, and traveling with a load).
- Capacities do not exceed 75% of minimum tipping loads. Capacities based on factors other than machine stability such as structural competence are shown by asterisk * in the charts located in the operator's crane cab.
- The machine must be reeved and set-up as stated in the operation manual and all the instruction manuals. If these manuals are missing, obtain replacements. Boom backstops are required for all boom lengths. Gantry must be in the fully raised position for all operations. Crawlers must be fully extended and be locked in position. The crane must be leveled to within 1% on a firm supporting surface.
- Do not attempt to lift where no radius or load is listed as crane may tip or collapse.
- Attempting to lift more than rated loads may cause machine to tip or collapse. Do not tip machine to determine capacity.
- Weight of hooks, hook blocks, slings and other lifting devices are a part of the total load. Their total weight must be subtracted from the rated load to obtain the weight that can be lifted.
- When lifting over boom point with jib or upper boom point installed, rated loads for the boom must be deducted as shown below.

| Jib length m (ft) | Upper boom point | 9,1 (30) | 12,2 (40) | 15,2 (50) | 18,3 (60) | 21,3 (70) |
|-------------------|------------------|--------------|--------------|--------------|--------------|--------------|
| Deduct kg (lb) | 318 (700) | 1100 (2,400) | 1500 (3,200) | 2000 (4,200) | 2400 (5,200) | 2900 (6,200) |

When lifting over luffing jib point with luffing jib roller assembly or pin connected boom point sheave (on the luffing boom top) attached, rated loads for the jib and sheave must be deducted as shown below.

| | Luffing jib point roller | Pin connected boom point sheave |
|----------------|--------------------------|---------------------------------|
| Deduct kg (lb) | 386 (850) | 218 (480) |

- The total load that can be lifted by the fixed jib is limited by rated jib loads. The total load that can be lifted with the upper boom point is limited by rated upper boom point loads.
- Boom lengths for fixed jib mounting are 27,4 m (90 ft) to 61,0 m (200 ft).
- The total load that can be lifted by the upper boom point is: the rated load for the luffing jib (without upper boom point installed) minus 386 kg (850 lb);

however, the upper boom point rated load should not exceed 11 300 kg (25,000 lb).

- An upper boom point cannot be used on a 70,1 m (230 ft) boom length.
- The boom should be erected over the front of the crawlers, not laterally.
- Least stable position is over the side.
- Maximum hoist load for number of reeving parts of line for hoist rope.

Maximum load for main boom

| No. of parts of line | 1 | 2 | 3 | 4 | 5 |
|-----------------------|-----------------|-----------------|-----------------|------------------|------------------|
| Maximum loads kg (lb) | 11 300 (25,000) | 22 600 (50,000) | 33 900 (75,000) | 45 200 (100,000) | 56 500 (125,000) |

| No. of parts of line | 6 | 7 | 8 | 9 | 10 |
|-----------------------|------------------|------------------|------------------|-------------------|-------------------|
| Maximum loads kg (lb) | 67 800 (150,000) | 79 100 (175,000) | 90 400 (200,000) | 101 700 (225,000) | 110 000 (240,000) |

Maximum load for luffing jib

| No. of parts of line | 1 | 2 | 3 | 4 |
|-----------------------|-----------------|-----------------|-----------------|-----------------|
| Maximum loads kg (lb) | 11 300 (25,000) | 22 600 (50,000) | 33 900 (75,000) | 36 200 (80,000) |

Maximum load for fixed jib

| No. of parts of line | 1 |
|-----------------------|-----------------|
| Maximum loads kg (lb) | 10 800 (24,000) |

Maximum load for upper boom point (on liftcrane boom)

| No. of parts of line | 1 | 2 |
|-----------------------|-----------------|-----------------|
| Maximum loads kg (lb) | 11 300 (25,000) | 22 600 (50,000) |

Maximum load for upper boom point (on luffing jib)

| No. of parts of line | 1 |
|-----------------------|-----------------|
| Maximum loads kg (lb) | 11 300 (25,000) |

Minimum weight of hook block required for lowering. (Luffing jib use)

| No. of parts of line | 1 | 2 | 3 | 4 |
|------------------------|-----------|-------------|-------------|-------------|
| Maximum weight kg (lb) | 272 (600) | 544 (1,200) | 680 (1,500) | 800 (1,800) |

- Lifting capacities listed apply only to the machine as originally manufactured for and supplied by Manitowoc Cranes, Inc. Modifications to this machine or use of equipment other than that specified can reduce operating capacity.
- Designed and rated to comply with ANSI Code B30.5.

Operation of this equipment in excess of rated loads or disregard of instruction voids the warranty.

Boom combinations

No. 12000 heavy-lift boom combinations

| Boom length m (ft) | Boom inserts | | |
|-----------------------|------------------|------------------|-------------------|
| | 3,1 m (10 ft) | 6,1 m (20 ft) | 12,2 m (40 ft) |
| 15,2 (50) | – | – | – |
| 18,3 (60) | 1 | – | – |
| 21,3 (70) | 2 | 1 | – |
| 24,4 (80) | 1 | 1 | – |
| 27,4 (90) | 2 | 1 | – |
| 30,5 (100) | 1 | 2 | – |
| 33,5 (110) | 2 | 2 | – |
| 36,6 (120) | 1 | 1 | 1* |
| 39,6 (130) | 2 | 1 | 1* |
| 42,7 (140) | 1 | 2 | 1* |
| 45,7 (150) | 2 | 2 | 1* |
| 48,8 (160) | 1 | 1 | 2* |
| 51,8 (170) | 2 | 1 | 2* |
| 54,9 (180) | 1 | 2 | 2* |
| 57,9 (190) | 2 | 2 | 2* |
| 61,0 (200) | 1 | 1 | 3* |
| 64,0 (210) | 2 | 1 | 3* |
| 67,0 (220) | 1 | 2 | 3* |
| 70,1 (230) | 2 | 2 | 3* |

* NOTE: One 40 ft (12,2 m) boom insert with lug 40A is required for fixed jib. When no jib is installed a 40 ft (12,2 m) boom can be used instead of 40A.

No. 12000 fixed jib combinations

| Fixed jib length m (ft) | Fixed jib inserts | |
|----------------------------|-------------------|------------------|
| | 3,1 m (10 ft) | 6,1 m (20 ft) |
| 9,1 (30) | – | – |
| 12,2 (40) | 1 | – |
| 15,2 (50) | – | 1 |
| 18,3 (60) | 1 | 1 |
| 21,3 (70) | – | 2 |

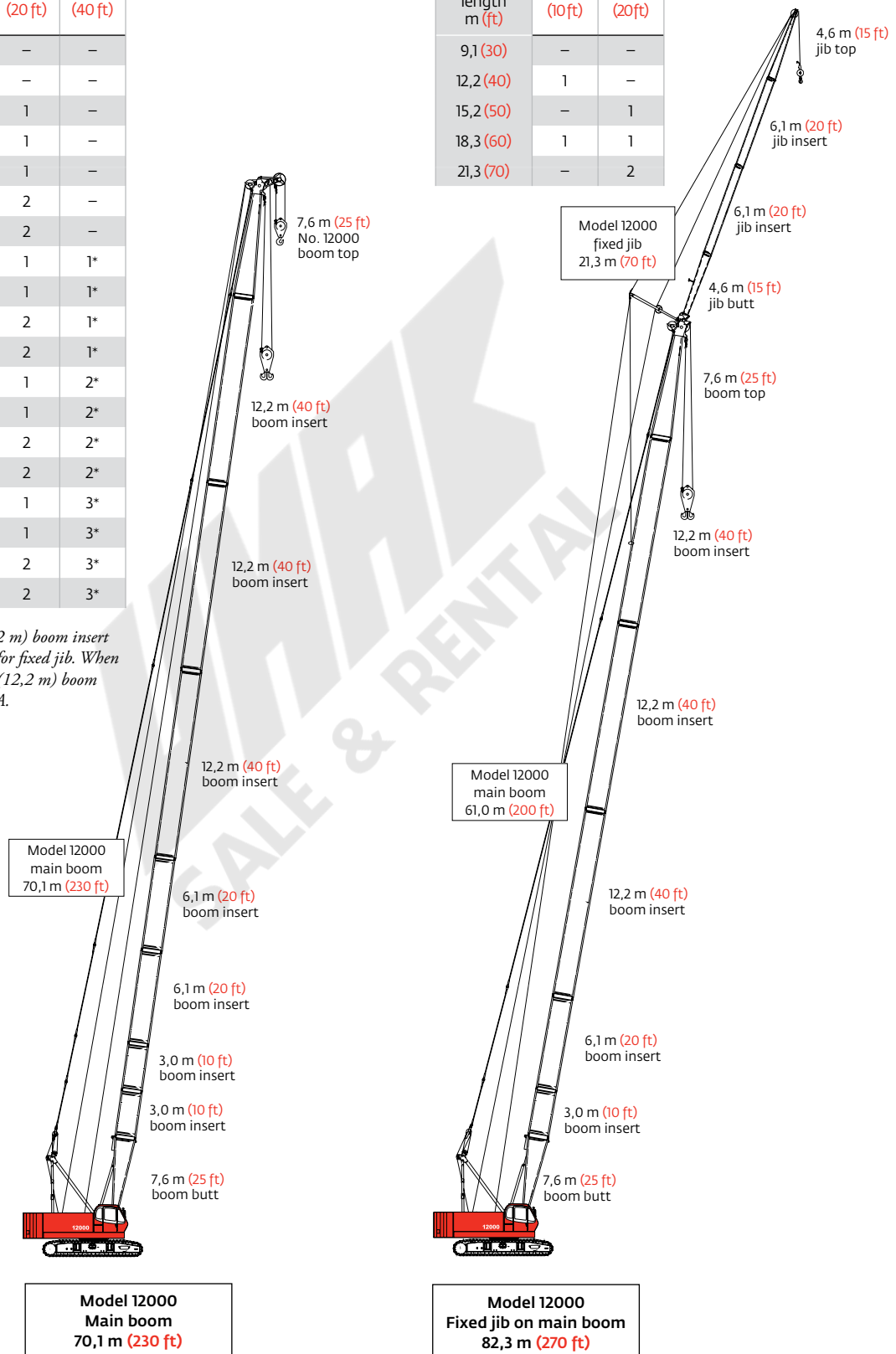

Boom combinations

No. 12000 luffing jib combinations

| Boom length m (ft) | Boom inserts | | |
|-----------------------|-----------------|-----------------|------------------|
| | 3,0m (10 ft) | 6,1m (20 ft) | 12,2m (40 ft) |
| 18,3 (60) | – | – | – |
| 21,3 (70) | 1 | – | – |
| 24,4 (80) | 2 | – | – |
| 27,4 (90) | 1 | 1 | – |
| 30,5 (100) | 2 | 1 | – |
| 33,5 (110) | 1 | – | 1 |
| 36,6 (120) | 2 | – | 1 |
| 39,6 (130) | 1 | 1 | 1 |
| 42,7 (140) | 2 | 1 | 1 |
| 45,7 (150) | 1 | – | 2 |
| 48,8 (160) | 2 | – | 2 |
| 51,8 (170) | 1 | 1 | 2 |

No. 12000 luffing boom combinations

| Boom length m (ft) | Boom inserts | | | |
|-----------------------|-----------------|-----------------|-----------------|------------------|
| | 3,0m (10 ft) | 6,1m (20 ft) | 9,1m (30 ft) | 12,2m (40 ft) |
| 18,3 (60) | – | – | 1* | – |
| 21,3 (70) | 1 | – | 1* | – |
| 24,3 (80) | 2 | – | 1* | – |
| 27,4 (90) | 1 | 1 | 1* | – |
| 30,5 (100) | 2 | 1 | 1* | – |
| 33,5 (110) | 1 | 2 | 1* | – |
| 36,6 (120) | 2 | 2 | 1* | – |
| 39,6 (130) | 1 | 1 | 1* | 1 |
| 42,7 (140) | 2 | 1 | 1* | 1 |
| 45,7 (150) | 1 | 2 | 1* | 1 |

NOTE: One 9,14 m (30') special luffing boom insert is required for luffing boom.

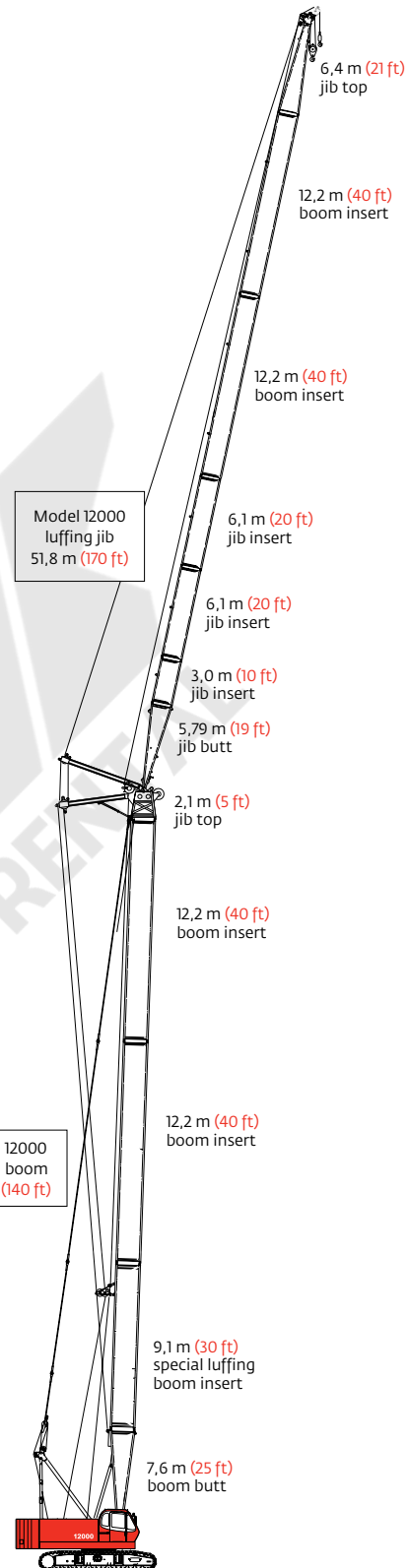

Model 12000
Luffing jib on luffing boom
94,5 m (310 ft)

Heavy-lift boom range diagram

No. 12000 main boom

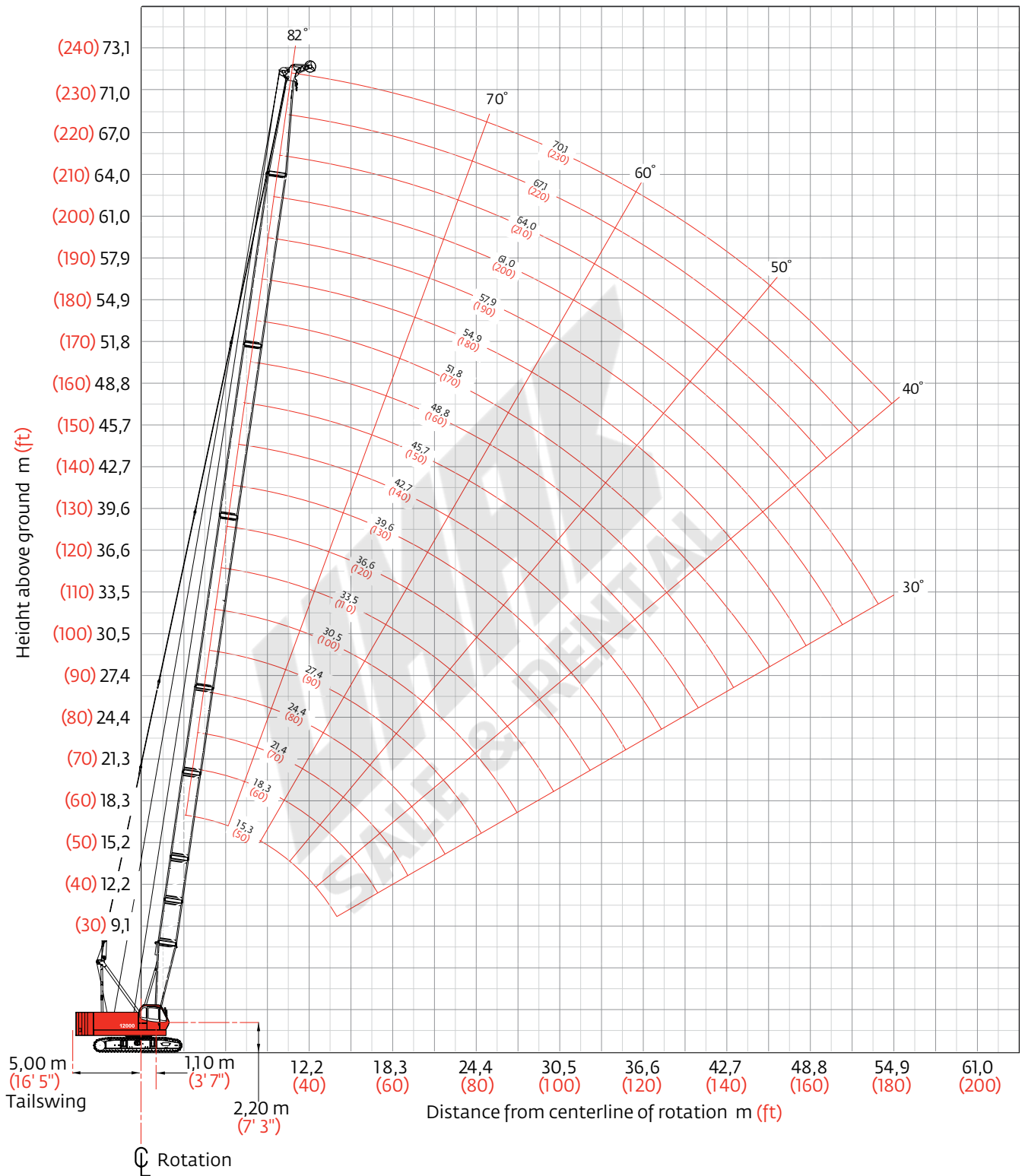

Heavy-lift boom load charts

Model 12000 liftcrane boom capacities - No. 12000 main boom

34 000 kg (75,000 lb) upper counterweight

360° Rating

kg (lb) x 1 000

| Boom m (ft) | 15,2 (50) | 18,3 (60) | 21,3 (70) | 24,4 (80) | 27,4 (90) | 30,5 (100) | 33,5 (110) | 36,6 (120) | 39,6 (130) | 42,7 (140) | 45,7 (150) | 48,8 (160) | 51,8 (170) | 54,9 (180) | 57,9 (190) | 61,0 (200) | 64,0 (210) | 67,1 (220) | 70,1 (230) |
|-------------------|------------------|-----------------|-----------------|-----------------|-----------------|-----------------|-----------------|-----------------|----------------|----------------|----------------|----------------|----------------|----------------|----------------|----------------|----------------|----------------|----------------|
| Radius | | | | | | | | | | | | | | | | | | | |
| 3,6 (12) | 110,0 (240.0) | | | | | | | | | | | | | | | | | | |
| 4,0 (14) | 99,1 (206.0) | — (204.0) | | | | | | | | | | | | | | | | | |
| 4,5 (16) | 88,4 (177.0) | 87,6 (177.0) | 86,2 (177.0) | | | | | | | | | | | | | | | | |
| 5,5 (18) | 68,0 (150.0) | 67,9 (150.0) | 67,9 (150.0) | 68,0 (150.0) | 67,9 (150.0) | | | | | | | | | | | | | | |
| 6,0 (20) | 62,0 (135.0) | 61,9 (135.0) | 61,9 (135.0) | 62,0 (135.0) | 61,9 (135.0) | 61,9 (135.0) | | | | | | | | | | | | | |
| 7,0 (24) | 53,6 (111.9) | 53,6 (111.7) | 53,6 (111.7) | 53,6 (111.5) | 53,6 (111.5) | 53,1 (111.3) | 53,0 (111.3) | 53,3 (111.1) | — (100.0) | | | | | | | | | | |
| 8,0 (28) | 44,5 (89.5) | 44,3 (89.2) | 44,3 (89.0) | 44,3 (88.8) | 44,3 (88.8) | 44,2 (88.6) | 44,1 (88.4) | 44,1 (88.4) | 44,0 (88.1) | 43,9 (87.9) | — (87.7) | | | | | | | | |
| 10,0 (34) | 32,8 (68.3) | 32,2 (68.1) | 32,2 (67.9) | 32,2 (67.4) | 32,2 (67.4) | 32,1 (67.2) | 32,0 (67.0) | 32,0 (67.0) | 31,9 (66.7) | 31,8 (66.5) | 31,7 (66.3) | 31,7 (66.3) | 31,6 (66.1) | 31,5 (65.9) | 30,0 (65.4) | | | | |
| 12,0 (40) | 25,6 (55.1) | 25,6 (54.6) | 25,3 (54.4) | 25,3 (54.2) | 24,6 (54.0) | 24,9 (53.7) | 24,8 (53.5) | 24,8 (53.5) | 24,7 (53.3) | 24,6 (53.1) | 24,4 (52.6) | 24,5 (52.9) | 24,3 (52.4) | 24,2 (52.2) | 24,1 (52.0) | 22,6 (50.0) | 22,6 (50.0) | 21,3 (46.7) | 19,5 (42.7) |
| 14,0 (45) | — (47.1) | 20,5 (46.7) | 20,5 (46.5) | 20,5 (46.2) | 20,5 (46.0) | 20,3 (45.8) | 20,2 (45.6) | 20,2 (45.6) | 20,1 (45.4) | 20,0 (45.1) | 19,8 (44.7) | 19,9 (44.9) | 19,7 (44.5) | 19,6 (44.3) | 19,5 (44.0) | 19,5 (44.0) | 19,4 (43.8) | 19,2 (43.4) | 17,9 (40.1) |
| 16,0 (55) | | 17,0 (36.1) | 17,0 (35.9) | 17,0 (35.4) | 17,0 (35.4) | 17,0 (35.0) | 16,9 (34.8) | 16,8 (34.8) | 16,8 (34.6) | 16,6 (34.3) | 16,5 (33.9) | 16,5 (33.9) | 16,4 (33.7) | 16,2 (33.2) | 16,1 (33.0) | 16,1 (33.0) | 16,0 (32.8) | 15,9 (32.6) | 15,7 (32.1) |
| 22,0 (75) | | | | | 11,5 (23.5) | 11,0 (23.1) | 11,0 (22.9) | 10,9 (22.7) | 10,8 (22.4) | 10,6 (22.2) | 10,5 (21.8) | 10,5 (21.8) | 10,4 (21.6) | 10,2 (21.1) | 10,0 (20.9) | 10,1 (20.9) | 10,0 (20.7) | 9,8 (20.2) | 9,6 (20.0) |
| 28,0 (95) | | | | | | | 7,9 (16.5) | 7,8 (16.3) | 7,7 (16.0) | 7,5 (15.6) | 7,4 (15.4) | 7,4 (15.4) | 7,2 (14.9) | 7,0 (14.7) | 6,9 (14.3) | 6,9 (14.3) | 6,8 (14.1) | 6,7 (13.8) | 6,5 (13.4) |
| 32,0 (105) | | | | | | | | 6,4 (14.1) | 6,3 (13.8) | 6,1 (13.4) | 6,0 (13.2) | 6,0 (13.2) | 5,8 (12.7) | 5,6 (12.3) | 5,5 (12.1) | 5,5 (12.1) | 5,4 (11.9) | 5,2 (11.4) | 5,1 (11.2) |
| 34,0 (115) | | | | | | | | | 5,8 (12.1) | 5,5 (11.6) | 5,4 (11.2) | 5,4 (11.2) | 5,2 (11.0) | 5,0 (10.5) | 4,9 (10.1) | 5,0 (10.3) | 4,8 (9.9) | 4,6 (9.7) | 4,5 (9.2) |
| 38,0 (125) | | | | | | | | | | 4,7 (10.3) | 4,5 (9.9) | 4,4 (9.7) | 4,3 (9.4) | 4,1 (9.0) | 4,0 (8.8) | 4,0 (8.8) | 3,8 (8.3) | 3,6 (7.9) | 3,4 (7.4) |
| 40,0 (135) | | | | | | | | | | | | 4,1 (8.5) | 3,9 (8.1) | 3,7 (7.7) | 3,5 (7.2) | 3,5 (7.2) | 3,4 (6.8) | 3,2 (6.6) | 3,0 (6.1) |
| 44,0 (145) | | | | | | | | | | | | | 3,2 (7.0) | 3,0 (6.6) | 2,8 (6.1) | 2,8 (6.1) | 2,6 (5.7) | 2,4 (5.2) | 2,2 (4.8) |
| 46,0 (155) | | | | | | | | | | | | | | 2,7 (5.7) | 2,5 (5.2) | 2,5 (5.0) | 2,3 (4.6) | 2,1 (4.4) | 1,9 (3.9) |
| 50,0 (165) | | | | | | | | | | | | | | | 2,0 (4.4) | 1,9 (4.1) | 1,7 (3.7) | 1,6 (3.5) | |
| 53,3 (175) | | | | | | | | | | | | | | | | 1,6 (3.5) | | | |

For complete chart, refer to www.cranelibrary.com.

Meets ANSI B30.5 Requirements - Capacities do not exceed 75% of static tipping load.
 NOTICE: This capacity chart is for reference only and must not be used for lifting purposes.

Fixed jib range diagram

No. 12000 fixed jib on main boom

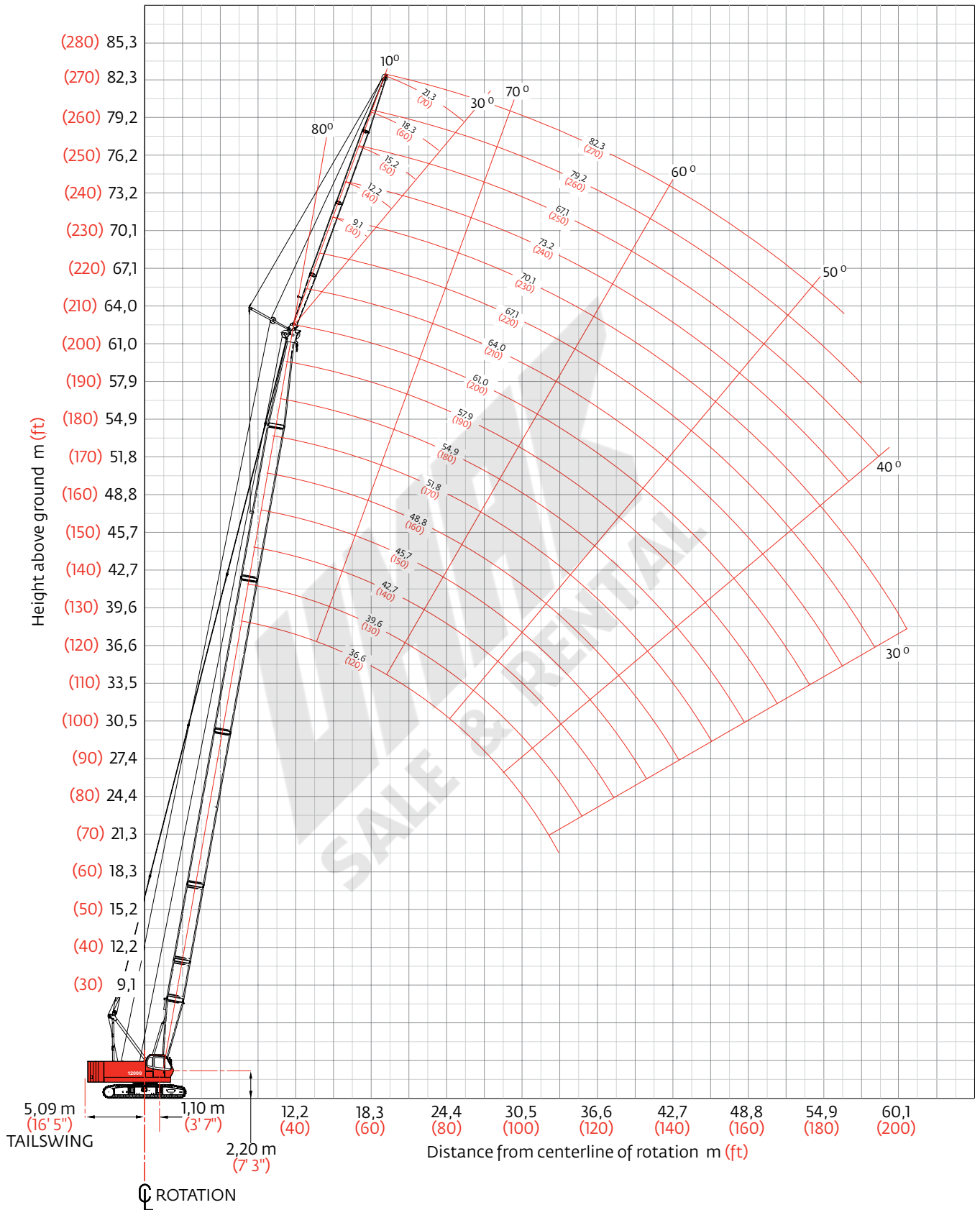

Fixed jib load charts

Model 12000 liftcrane fixed jib capacities - No. 12000 fixed jib on main boom

34 000 kg (75,000 lb) upper counterweight

360° Rating

kg (lb) x 1 000

10° offset

30° offset

| Boom m (ft) | 27,4 (90) | 36,6 (120) | 48,8 (160) | 54,9 (180) | 61,0 (200) |
|----------------|----------------|----------------|----------------|----------------|----------------|
| Radius | | | | | |
| 10,0 (30) | 10,8 (24.0) | | | | |
| 12,0 (40) | 10,8 (24.0) | 10,8 (24.0) | | | |
| 14,0 (50) | 10,8 (24.0) | 10,8 (24.0) | 10,8 (24.0) | — (24.0) | — (24.0) |
| 18,0 (60) | 10,8 (24.0) | 10,8 (24.0) | 10,8 (24.0) | 10,8 (24.0) | 10,8 (24.0) |
| 24,0 (80) | 10,1 (21.9) | 9,7 (21.1) | 9,3 (20.1) | 9,0 (19.8) | 8,8 (19.0) |
| 30,0 (100) | 7,4 (16.1) | 7,1 (15.3) | 6,6 (14.2) | 6,3 (13.6) | 6,1 (13.1) |
| 36,0 (120) | | 5,3 (11.6) | 4,8 (10.4) | 4,5 (9.8) | 4,3 (9.3) |
| 42,0 (140) | | | 3,6 (7.8) | 3,3 (7.1) | 3,0 (6.5) |
| 48,0 (160) | | | 2,7 (5.8) | 2,3 (4.9) | 2,0 (4.2) |
| 52,0 (175) | | | 2,2 (—) | 1,7 (3.6) | 1,5 (—) |
| 56,0 (185) | | | | | |

| Boom m (ft) | 27,4 (90) | 36,6 (120) | 48,8 (160) | 54,9 (180) | 61,0 (200) |
|----------------|---------------|---------------|---------------|---------------|---------------|
| Radius | | | | | |
| 10,0 (30) | | | | | |
| 12,0 (40) | — (21.0) | | | | |
| 14,0 (50) | 9,5 (21.0) | 9,5 (21.0) | | | |
| 18,0 (60) | 9,5 (21.0) | 9,5 (21.0) | 9,5 (21.0) | 9,5 (21.0) | — |
| 24,0 (80) | 8,6 (18.9) | 9,4 (20.8) | 9,4 (20.8) | 9,2 (20.2) | 9,1 (19.9) |
| 30,0 (100) | | 7,2 (15.6) | 6,8 (14.7) | 6,5 (14.1) | 6,4 (13.7) |
| 36,0 (120) | | | 5,0 (10.7) | 4,7 (10.2) | 4,5 (9.7) |
| 42,0 (140) | | | | 3,4 (7.4) | 3,2 (7.0) |
| 48,0 (160) | | | | | 2,3 (—) |
| 52,0 (175) | | | | | |
| 56,0 (185) | | | | | |

| Boom m (ft) | 27,4 (90) | 36,6 (120) | 48,8 (160) | 54,9 (180) | 61,0 (200) |
|----------------|---------------|---------------|---------------|---------------|---------------|
| Radius | | | | | |
| 10,0 (30) | 9,0 (—) | | | | |
| 12,0 (40) | 9,0 (20.0) | 9,0 (—) | | | |
| 14,0 (50) | 9,0 (20.0) | 9,0 (20.0) | 9,0 (20.0) | | |
| 18,0 (60) | 9,0 (20.0) | 9,0 (20.0) | 9,0 (20.0) | 9,0 (20.0) | 9,0 (20.0) |
| 24,0 (80) | 7,7 (16.8) | 8,9 (19.5) | 9,0 (20.0) | 9,0 (20.0) | 8,9 (19.7) |
| 30,0 (100) | 6,2 (13.6) | 7,2 (15.7) | 6,8 (14.7) | 6,5 (14.1) | 6,3 (13.6) |
| 36,0 (120) | 5,2 (11.5) | 5,5 (11.9) | 5,0 (10.8) | 4,7 (10.2) | 4,5 (9.8) |
| 42,0 (140) | | 4,3 (9.3) | 3,8 (8.2) | 3,5 (7.5) | 3,3 (7.1) |
| 48,0 (160) | | | 2,9 (6.2) | 2,5 (5.4) | 2,2 (4.7) |
| 52,0 (175) | | | 2,3 (4.9) | 1,9 (4.0) | 1,6 (3.3) |
| 58,0 (185) | | | 1,8 (4.1) | | |

| Boom m (ft) | 27,4 (90) | 36,6 (120) | 48,8 (160) | 54,9 (180) | 61,0 (200) |
|----------------|---------------|---------------|---------------|---------------|---------------|
| Radius | | | | | |
| 10,0 (30) | | | | | |
| 12,0 (40) | | | | | |
| 14,0 (50) | | | | | |
| 18,0 (60) | 5,1 (11.4) | 5,1 (11.4) | 5,1 (—) | | |
| 24,0 (80) | 5,1 (11.2) | 5,1 (11.2) | 5,1 (11.4) | 5,1 (11.4) | 5,1 (11.4) |
| 30,0 (100) | 4,4 (9.8) | 4,8 (10.6) | 5,1 (11.4) | 5,1 (11.4) | 5,1 (11.4) |
| 36,0 (120) | | 4,3 (9.6) | 4,7 (10.4) | 4,9 (10.8) | 4,9 (10.6) |
| 42,0 (140) | | | 4,0 (8.6) | 3,7 (8.1) | 3,6 (7.7) |
| 48,0 (160) | | | | 2,7 (5.9) | 2,5 (5.3) |
| 52,0 (175) | | | | | 1,9 (3.8) |
| 58,0 (185) | | | | | |

For complete chart, refer to www.cranelibrary.com.

Fixed jib load charts

Model 12000 liftcrane fixed jib capacities - No. 12000 fixed jib on main boom

34 000 kg (75,000 lb) upper counterweight
360° Rating

kg (lb) x 1 000

| 10° offset | | | | | | 30° offset | | | | | |
|--------------------|---------------|---------------|---------------|---------------|---------------|----------------|--------------|---------------|---------------|---------------|---------------|
| Boom m (ft) | 27,4 (90) | 36,6 (120) | 48,8 (160) | 54,9 (180) | 61,0 (200) | Boom m (ft) | 27,4 (90) | 36,6 (120) | 48,8 (160) | 54,9 (180) | 61,0 (200) |
| Radius | | | | | | Radius | | | | | |
| jib 21,3 m (70 ft) | 12,0 (45) | 7,1 (15.7) | | | | 12,0 (45) | | | | | |
| | 18,0 (60) | 6,7 (14.8) | 6,8 (15.1) | 6,9 (15.4) | 7,0 (15.6) | 7,1 (15.7) | 3,6 (—) | | | | |
| | 22,0 (75) | 6,4 (13.9) | 6,6 (14.4) | 6,7 (14.8) | 6,8 (15.0) | 6,9 (15.1) | 3,6 (8.1) | 3,6 (8.1) | | | |
| | 26,0 (90) | 5,5 (11.5) | 6,3 (13.3) | 6,5 (14.3) | 6,6 (14.4) | 6,7 (14.6) | 3,5 (7.6) | 3,6 (8.1) | 3,6 (8.1) | 3,6 (8.1) | 3,6 (8.1) |
| | 32,0 (110) | 4,4 (9.4) | 5,1 (10.9) | 6,0 (12.7) | 6,0 (12.3) | 5,8 (11.9) | 3,0 (6.5) | 3,3 (7.0) | 3,5 (7.6) | 3,6 (7.8) | 3,6 (8.0) |
| | 38,0 (130) | 3,7 (7.9) | 4,3 (9.2) | 4,7 (9.7) | 4,4 (9.1) | 4,2 (8.6) | 2,7 (—) | 2,9 (6.3) | 3,1 (6.9) | 3,2 (7.1) | 3,3 (7.3) |
| | 44,0 (145) | 3,2 (7.1) | 3,7 (8.2) | 3,6 (7.9) | 3,3 (7.2) | 3,1 (6.8) | | 2,6 (5.9) | 2,9 (6.4) | 3,0 (6.6) | 3,0 (6.8) |
| | 50,0 (170) | | 3,2 (6.8) | 2,7 (5.6) | 2,4 (4.7) | 2,0 (4.1) | | | 2,6 (5.9) | 2,7 (5.5) | 2,5 (4.9) |
| | 54,0 (180) | | | 2,2 (4.8) | 1,8 (3.9) | | | | | 2,1 (4.5) | 1,8 (3.9) |
| | 56,0 (190) | | | 2,0 (4.0) | 1,6 (—) | | | | | | 1,6 (—) |
| | 60,0 (200) | | | 1,6 (3.3) | | | | | | | |

For complete chart, refer to www.cranelibrary.com.

Meets ANSI B30.5 Requirements - Capacities do not exceed 75% of static tipping load.
NOTICE: This capacity chart is for reference only and must not be used for lifting purposes.

Luffing jib range diagram

No. 12000 luffing jib on luffing boom

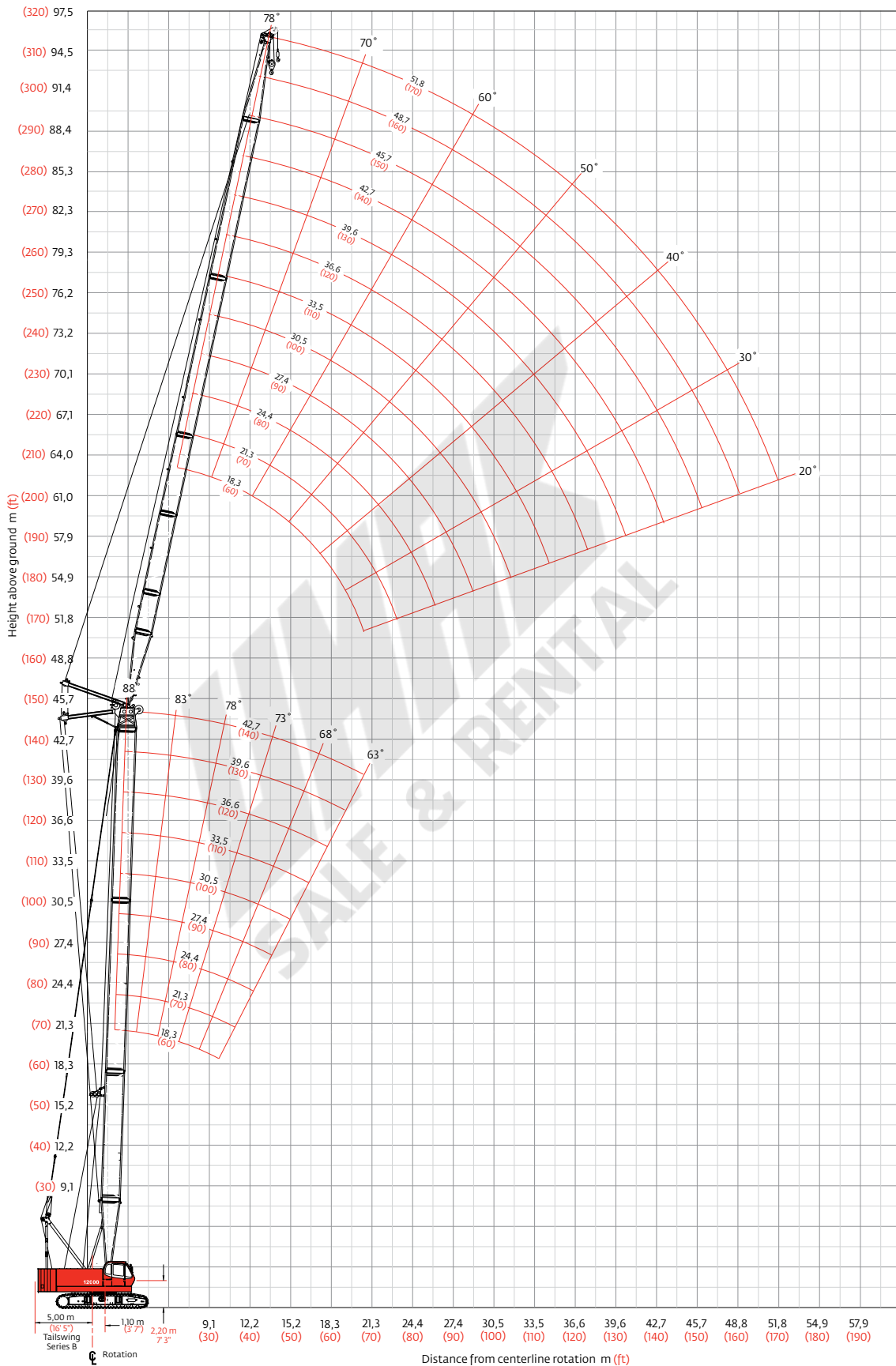

Luffing jib load charts

Model 12000 liftcrane luffing jib capacities - No. 12000 luffing jib on luffing boom

34 000 kg (75,000 lb) counterweight
360° Rating

kg (lb) x1000

88° boom angle

| | Boom m (ft) | 18,2 (60) | 24,4 (80) | 30,5 (100) | 36,6 (120) | 45,7 (150) |
|-----------------------------------|----------------|----------------|----------------|----------------|----------------|----------------|
| Luffing jib length 18,3 m (60 ft) | Radius | | | | | |
| | 7,9 (26) | 36,2 (80.0) | — (80.0) | | | |
| | 9,0 (30) | 31,9 (69.3) | 31,9 (69.3) | 31,9 (69.3) | 31,9 (69.3) | 19,5 (42.5) |
| | 10,0 (36) | 28,8 (57.7) | 28,7 (57.7) | 28,7 (57.7) | 28,7 (57.7) | 17,9 (36.4) |
| | 14,0 (45) | 20,4 (46.2) | 20,5 (46.2) | 20,5 (46.2) | 20,5 (46.2) | 12,9 (29.1) |
| | 18,0 (65) | 14,1 (—) | 14,4 (26.9) | 14,6 (27.3) | 14,8 (27.6) | 9,5 (18.3) |
| | 20,0 (80) | 11,2 (—) | 11,3 (—) | 11,5 (—) | 11,8 (—) | 7,9 (—) |
| | 24,0 (80) | | | | | |
| | 30,0 (100) | | | | | |
| | 36,0 (120) | | | | | |
| 44,0 (145) | | | | | | |

| | Boom m (ft) | 18,2 (60) | 24,4 (80) | 30,5 (100) | 36,6 (120) | 45,7 (150) |
|------------------------------------|----------------|----------------|----------------|----------------|----------------|----------------|
| Luffing jib length 30,5 m (100 ft) | Radius | | | | | |
| | 7,9 (26) | | | | | |
| | 9,0 (30) | | | | | |
| | 10,0 (36) | — (57.7) | | | | |
| | 14,0 (45) | 20,5 (46.2) | 20,5 (46.2) | 20,5 (46.2) | 20,5 (46.2) | 12,6 (28.4) |
| | 18,0 (65) | 14,7 (28.0) | 15,0 (28.4) | 15,2 (28.9) | 15,4 (29.1) | 9,6 (19.0) |
| | 24,0 (80) | 9,4 (20.3) | 9,4 (20.3) | 9,5 (20.5) | 9,6 (20.7) | 6,6 (14.3) |
| | 30,0 (100) | 6,4 (13.7) | 6,4 (13.7) | 6,4 (13.7) | 6,4 (13.7) | 4,5 (9.7) |
| | 32,0 (120) | | | 5,4 (—) | 5,5 (—) | 3,9 (—) |
| | 36,0 (120) | | | | | |
| 44,0 (145) | | | | | | |

| | Boom m (ft) | 18,2 (60) | 24,4 (80) | 30,5 (100) | 36,6 (120) |
|------------------------------------|----------------|----------------|----------------|----------------|----------------|
| Luffing jib length 39,6 m (130 ft) | Radius | | | | |
| | 14,0 (45) | 20,7 (46.2) | 20,7 (46.2) | 20,7 (46.2) | |
| | 16,0 (55) | 17,7 (36.8) | 17,9 (37.5) | 17,9 (37.5) | 17,1 (36.4) |
| | 22,0 (75) | 10,9 (22.7) | 11,0 (22.9) | 11,2 (23.1) | 11,3 (23.4) |
| | 28,0 (95) | 7,3 (15.2) | 7,4 (15.4) | 7,4 (15.4) | 7,5 (15.7) |
| | 34,0 (115) | 5,0 (10.6) | 5,1 (10.6) | 5,1 (10.6) | 5,1 (10.8) |
| | 40,0 (130) | 3,4 (8.2) | 3,4 (8.2) | 3,4 (8.2) | 3,4 (8.2) |
| | 44,0 (150) | | | | |
| | 50,0 (165) | | | | |
| | 52,0 (175) | | | | |
| 56,0 (190) | | | | | |

| | Boom m (ft) | 18,2 (60) | 24,4 (80) | 30,5 (100) | 36,6 (120) |
|------------------------------------|----------------|----------------|----------------|----------------|----------------|
| Luffing jib length 51,8 m (170 ft) | Radius | | | | |
| | 14,0 (45) | | | | |
| | 16,0 (55) | — (30.0) | — (30.2) | | |
| | 22,0 (75) | 10,3 (21.6) | 10,4 (21.8) | 10,4 (22.0) | 10,6 (22.3) |
| | 28,0 (95) | 6,8 (14.1) | 6,9 (14.3) | 6,9 (14.3) | 7,0 (14.6) |
| | 34,0 (115) | 4,6 (9.7) | 4,6 (9.7) | 4,7 (9.7) | 4,7 (9.7) |
| | 40,0 (130) | 3,2 (7.3) | 3,2 (7.3) | 3,2 (7.3) | 2,6 (6.2) |
| | 44,0 (150) | 2,6 (4.9) | 2,6 (4.0) | 1,6 (—) | |
| | 50,0 (165) | — (2.2) | | | |
| | 52,0 (175) | | | | |
| 56,0 (190) | | | | | |

For complete chart, refer to www.cranelibrary.com.

Meets ANSI B30.5 Requirements - Capacities do not exceed 75% of static tipping load.
NOTICE: This capacity chart is for reference only and must not be used for lifting purposes.

Luffing jib load charts

Model 12000 liftcrane luffing jib capacities - No. 12000 luffing jib on luffing boom

34 000 kg (75,000 lb) counterweight

360° Rating

kg (lb) x1 000

73° boom angle

| | Boom m (ft) | 18,2 (60) | 24,4 (80) | 30,5 (100) | 36,6 (120) | 45,7 (150) | | Boom m (ft) | 18,2 (60) | 24,4 (80) | 30,5 (100) | 36,6 (120) | 45,7 (150) |
|-----------------------------------|----------------|----------------|----------------|----------------|---------------|---------------|---------------|----------------|---------------|---------------|---------------|---------------|---------------|
| | Radius | | | | | | | | Radius | | | | |
| Luffing jib length 18,3 m (60 ft) | 16,0 (55) | — (35.9) | | | | | 16,0 (55) | | | | | | |
| | 20,0 (65) | 13,0 (29.1) | 12,4 (27.6) | | | | 20,0 (65) | | | | | | |
| | 22,0 (75) | 11,5 (24.0) | 11,0 (23.1) | 10,4 (22.3) | — (20.3) | | 22,0 (75) | | | | | | |
| | 26,0 (85) | | 8,5 (19.6) | 8,4 (18.7) | 8,0 (17.9) | 6,9 (15.4) | 26,0 (85) | 8,8 (19.6) | 8,1 (17.9) | | | | |
| | 28,0 (95) | | | 7,4 (—) | 7,2 (15.2) | 6,6 (13.9) | 28,0 (95) | 7,9 (16.8) | 7,5 (15.9) | 6,9 (15.0) | — (13.0) | | |
| | 32,0 (105) | | | | | 5,3 (11.9) | 32,0 (105) | 6,6 (14.6) | 6,2 (13.7) | 5,8 (13.0) | 5,4 (12.1) | 4,2 (9.3) | |
| | 34,0 (115) | | | | | | 34,0 (115) | 5,9 (12.8) | 5,6 (11.9) | 5,3 (11.2) | 4,9 (10.4) | 4,1 (9.0) | 4,1 (9.0) |
| | 38,0 (125) | | | | | | 38,0 (125) | | 4,7 (—) | 4,5 (9.9) | 4,1 (9.0) | 3,5 (7.7) | 3,5 (7.7) |
| | 40,0 (135) | | | | | | 40,0 (135) | | | | 3,8 (7.9) | 3,1 (6.6) | 3,1 (6.6) |
| | 42,0 (140) | | | | | | 42,0 (140) | | | | | | 2,8 (6.2) |

| | Boom m (ft) | 18,2 (60) | 24,4 (80) | 30,5 (100) | 36,6 (120) | | Boom m (ft) | 18,2 (60) | 24,4 (80) | 30,5 (100) | 36,6 (120) |
|------------------------------------|----------------|---------------|---------------|---------------|---------------|---------------|----------------|--------------|--------------|---------------|---------------|
| | Radius | | | | | | | Radius | | | |
| Luffing jib length 39,6 m (130 ft) | 28,0 (95) | — (15.2) | | | | 28,0 (95) | | | | | |
| | 32,0 (105) | 6,3 (13.9) | 5,8 (13.0) | — (11.2) | | 32,0 (105) | | | | | |
| | 34,0 (115) | 5,7 (12.1) | 5,3 (11.2) | 5,0 (10.6) | 4,2 (9.3) | 34,0 (115) | — (10.1) | | | | |
| | 38,0 (125) | 4,8 (10.6) | 4,5 (9.9) | 4,2 (9.3) | 3,7 (8.2) | 38,0 (125) | 4,3 (9.5) | 3,8 (8.4) | — (6.6) | | |
| | 40,0 (135) | 4,4 (9.3) | 4,1 (8.6) | 3,8 (7.9) | 3,4 (7.1) | 40,0 (135) | 3,9 (8.4) | 3,6 (7.5) | 2,9 (6.6) | 2,2 (4.9) | |
| | 44,0 (145) | 3,7 (8.2) | 3,5 (7.7) | 3,1 (6.8) | 2,8 (6.2) | 44,0 (145) | 3,2 (7.1) | 2,9 (6.4) | 2,5 (5.5) | 2,1 (4.6) | |
| | 46,0 (155) | | 3,2 (—) | 2,8 (6.0) | 2,5 (5.3) | 46,0 (155) | 2,9 (6.2) | 2,6 (5.5) | 2,2 (4.6) | 1,8 (4.0) | |
| | 48,0 (160) | | | 2,6 (—) | 2,3 (4.9) | 48,0 (160) | 2,7 (5.7) | 2,4 (5.1) | 1,9 (4.2) | 1,7 (3.5) | |
| | 52,0 (175) | | | | | 52,0 (175) | 2,2 (4.6) | 1,8 (4.0) | 1,5 (3.3) | | |
| | 56,0 (185) | | | | | 56,0 (185) | 1,7 (—) | 1,5 (3.3) | | | |

For complete chart, refer to www.cranelibrary.com.

Meets ANSI B30.5 Requirements - Capacities do not exceed 75% of static tipping load.
NOTICE: This capacity chart is for reference only and must not be used for lifting purposes.

Luffing jib load charts

Model 12000 liftcrane luffing jib capacities - No. 12000 luffing jib on luffing boom

34 000 kg (75,000 lb) counterweight

360° Rating

kg (lb) x 1000

63° boom angle

| Boom m (ft) | 18,2 (60) | 24,4 (80) | 30,5 (100) | 36,6 (120) | 45,7 (150) |
|--|---------------|---------------|---------------|---------------|---------------|
| Luffing jib length 18,3 m (60 ft) | | | | | |
| Radius | | | | | |
| 22,0 (75) | — (22.5) | | | | |
| 24,0 (80) | 9,7 (21.2) | | | | |
| 26,0 (85) | 8,6 (19.4) | 7,9 (17.6) | | | |
| 28,0 (95) | | 7,4 (15.7) | — (13.7) | | |
| 32,0 (105) | | | 5,5 (12.3) | 4,7 (10.4) | |
| 34,0 (115) | | | | 4,6 (9.7) | — (6.4) |
| 38,0 (125) | | | | | 2,9 (6.4) |
| 40,0 (135) | | | | | |
| 44,0 (145) | | | | | |
| 46,0 (150) | | | | | |

| Boom m (ft) | 18,2 (60) | 24,4 (80) | 30,5 (100) | 36,6 (120) |
|---|---------------|---------------|---------------|---------------|
| Luffing jib length 30,5 m (100 ft) | | | | |
| Radius | | | | |
| 22,0 (75) | | | | |
| 24,0 (80) | | | | |
| 26,0 (85) | | | | |
| 28,0 (95) | | | | |
| 32,0 (105) | 6,0 (13.4) | | | |
| 34,0 (115) | 5,5 (11.7) | 4,8 (10.6) | | |
| 38,0 (125) | 4,7 (10.4) | 4,2 (9.3) | 3,5 (7.9) | |
| 40,0 (135) | | 3,9 (8.2) | 3,3 (7.1) | 2,4 (5.3) |
| 44,0 (145) | | | 2,8 (6.2) | 2,2 (4.9) |
| 46,0 (150) | | | | 2,0 (4.4) |

| Boom m (ft) | 18,2 (60) | 24,4 (80) | 30,5 (100) |
|---|--------------|--------------|---------------|
| Luffing jib length 39,6 m (130 ft) | | | |
| Radius | | | |
| 36,0 (120) | — (9.7) | | |
| 38,0 (125) | 4,4 (9.7) | | |
| 40,0 (130) | 4,0 (9.0) | 3,2 (7.1) | |
| 42,0 (140) | 3,6 (7.9) | 3,1 (6.8) | — (4.6) |
| 44,0 (150) | 3,4 (7.1) | 2,9 (6.0) | 2,0 (4.6) |
| 48,0 (160) | 2,9 (—) | 2,4 (5.1) | 1,9 (4.0) |
| 50,0 (170) | | 2,1 (—) | 1,7 (3.3) |
| 52,0 (175) | | | 1,5 (3.1) |
| 54,0 (180) | | | |
| 58,0 (190) | | | |

| Boom m (ft) | 18,2 (60) |
|---|--------------|
| Luffing jib length 51,8 m (170 ft) | |
| Radius | |
| 36,0 (120) | |
| 38,0 (125) | |
| 40,0 (130) | |
| 42,0 (140) | |
| 44,0 (150) | — (5.1) |
| 48,0 (160) | 2,2 (4.9) |
| 50,0 (170) | 2,0 (4.0) |
| 52,0 (175) | 1,7 (3.7) |
| 54,0 (180) | 1,6 (3.3) |
| 58,0 (190) | — (2.9) |

For complete chart, refer to www.cranelibrary.com.

Meets ANSI B30.5 Requirements - Capacities do not exceed 75% of static tipping load.
NOTICE: This capacity chart is for reference only and must not be used for lifting purposes.

Clamshell

Boom:

Welded lattice construction using tubular, high-tensile steel chords with pin connections between sections.

Basic boom length: 15,2 m (50 ft)

Max. boom length: 30,5 m (100 ft)

Limit of empty clamshell bucket weight: 2 100 kg (4,600 lb)

Boom component chart

| Boom length m (ft) | Boom arrangement |
|--------------------|--|
| 15,2 (50) | Base-Tip |
| 18,3 (60) | Base-A-Tip |
| 21,3 (70) | Base-A-A-Tip, Base-B-Tip |
| 24,4 (80) | Base-A-B-Tip |
| 27,4 (90) | Base-A-A-B-Tip, Base-B-B-Tip, Base-C-Tip |
| 30,5 (100) | Base-A-B-B-Tip, Base-A-C-Tip |

Base = 7,6 m (25 ft)

Insert: A = 3,05 m (10 ft)

B = 6,10 m (20 ft)

C = 12,2 m (40 ft)

Tip = 7,2 m (25 ft)

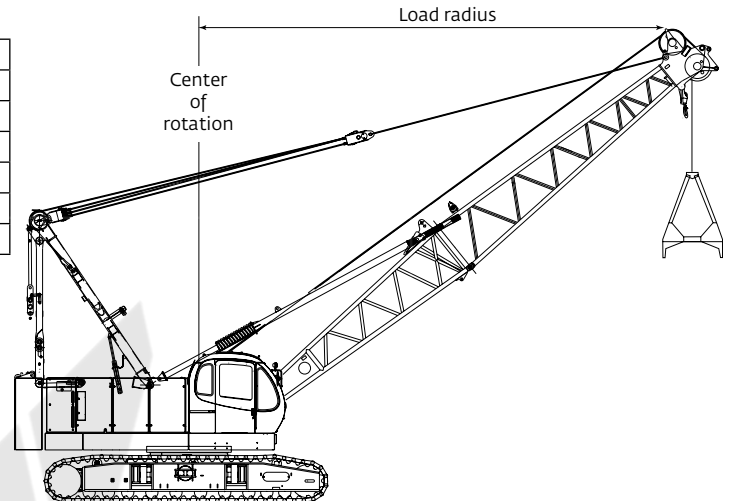

1. Figures represent maximum allowable capacity, and assume level ground and ideal working conditions.
2. Capacities are calculated at 66% of the minimum tipping loads.
3. Capacities are maximum recommended by PCSA Standard #4. Allowances must be made by the user for such unfavorable conditions as a soft or uneven supporting surface, rapid cycle operations, or bucket suction.
4. The combined weight of the bucket and load must not exceed these capacities.
5. Boom length for clamshell operation should not exceed 30,5 m (100 ft).

Clamshell Capacities

10 000 kg (22,050 lb) counterweight
(one upper counterweight, crawlers extended)

kg (lb) x 1 000

| Boom m (ft) | 15,2 (50) | 18,3 (60) | 21,3 (70) | 24,4 (80) | 27,4 (90) | 30,5 (100) |
|-------------|-------------|-------------|------------|------------|------------|------------|
| Radius | | | | | | |
| 7,0 (22) | 10,0 (25.0) | | | | | |
| 8,0 (26) | 10,0 (25.0) | | | | | |
| 9,0 (30) | 10,0 (25.0) | 10,0 (25.0) | | | | |
| 10,0 (34) | 10,0 (25.0) | 9,7 (25.0) | 9,7 (25.0) | | | |
| 14,0 (45) | 10,0 (23.1) | 7,8 (22.9) | 7,8 (22.7) | 7,8 (22.5) | 7,8 (21.6) | |
| 15,0 (50) | | 6,6 (19.8) | 6,6 (19.6) | 6,6 (19.4) | 6,6 (19.2) | 6,6 (18.5) |
| 17,0 (55) | | 5,7 (12.5) | 5,7 (17.2) | 5,7 (17.0) | 5,7 (16.8) | 5,7 (16.5) |
| 18,0 (60) | | | 5,0 (15.2) | 5,0 (15.0) | 5,0 (14.8) | 5,0 (14.6) |
| 21,0 (70) | | | | 4,4 (11.9) | 4,3 (11.7) | 4,2 (11.5) |
| 24,0 (80) | | | | | — (9.5) | — (9.3) |
| 25,0 (85) | | | | | | — (8.4) |
| 27,0 (90) | | | | | | — (7.7) |

Manitowoc Crane Care

Crane Care is Manitowoc's comprehensive service and support program. It includes classroom and on-site training, prompt parts availability, expert field service, technical support and documentation.

That's commitment you won't find anywhere else.

That's Crane Care.

Service training

Manitowoc specialists work with you in our training centers and in the field to make sure you know how to get maximum performance, reliability and life from your cranes.

Manitowoc Cranes Technical Training Centers provide valuable multi-level training, which is available for all models and attachments, in the following format:

- **Intro to Canbus and Canbus 1, 2, 3**
- **Intro to EPIC and EPIC 1, 2, 3**
- **Small Crawler 1**
- **Canbus 1 and 2 assembly, operation and maintenance**
- **EPIC 1 and 2 assembly, operation and maintenance**

Refer to www.manitowoc.com for course descriptions.

Parts availability

Genuine Manitowoc replacement parts are accessible through your distributor 24 hours a day, 7 days a week, 365 days a year.

Service interval kits

200 hour kit

1,000 hour kit

2,000 hour kit

Hydraulic test kit

U.S. standard tools kit

Field service

Factory-trained service experts are always ready to help maintain your crane's peak performance.

For a worldwide listing of dealer locations, please consult our website at: www.manitowoc.com

Technical support

Manitowoc's dealer network and factory personnel are available 24 hours a day, 7 days a week, 365 days a year to answer your technical questions and more, with the help of computerized programs that simplify crane selection, lift planning, and ground-bearing calculations.

For a worldwide listing of dealer locations, please consult our website at: www.manitowoc.com

Technical documentation

Manitowoc has the industry's most extensive documentation; available in major languages and formats that include print, videotape, and DVD/CD.

Additional copies available through your Authorized Manitowoc Distributor.

- Crane operator's manual
- Crane parts manual
- Crane capacity manual
- Crane vendor manual
- Crane service manual
- Luffing jib operator's/parts manual
- Capacity chart manual - attachments

CD rom versions of the operator's and parts manuals are shipped with each crane. Also available are the following CDs:

- Crane Care Owner CD –
- Ground Bearing Pressure Estimator CD
- Crane Selection and Planning Software (CompuCRANE®)
- EPIC® Crane Library CD consisting of capacity charts, range diagrams, wire rope specifications, travel specifications, crane weights, counterweight arrangements, luffing jib raising procedures, operating range diagrams, drum and lagging charts, boom rigging drawings, jib rigging drawings, outline dimensions and wind condition charts.

Available from your Authorized Manitowoc Cranes Distributor, these videos are available in NTSC, PAL, SECAM, and DVD formats.

- Your Capacity Chart Video
- Respect the Limits Video
- Crane Safety Video
- Boom Inspection/Repair Video

Crane Care Package

Manitowoc has assembled all of the available literature, CD's and videos listed above plus several Manitowoc premiums into one complete Crane Care Package.



Manitowoc Cranes

Regional headquarters

Americas

Manitowoc, Wisconsin, USA

Tel: +1 920 684 6621

Fax: +1 920 683 6277

Shady Grove, Pennsylvania, USA

Tel: +1 717 597 8121

Fax: +1 717 597 4062

Europe, Middle East, Africa

Ecully, France

Tel: +33 (0)4 72 18 20 20

Fax: +33 (0)4 72 18 20 00

China

Shanghai, China

Tel: +86 21 6457 0066

Fax: +86 21 6457 4955

Greater Asia-Pacific

Singapore

Tel: +65 6264 1188

Fax: +65 6862 4040

Regional offices

Americas

Brazil

Alphaville

Mexico

Monterrey

Chile

Santiago

Europe, Middle East,

Africa

Czech Republic

Netvorice

France

Baudemont

Cergy

Decines

Germany

Langenfeld

Hungary

Budapest

Italy

Lainate

Netherlands

Breda

Poland

Warsaw

Portugal

Baltar

Russia

Moscow

U.A.E.

Dubai

U.K.

Buckingham

China

Beijing

Chengdu

Guangzhou

Xian

Greater Asia-Pacific

Australia

Adelaide

Brisbane

Melbourne

Sydney

India

Calcutta

Chennai

Delhi

Hyderabad

Pune

Korea

Seoul

Philippines

Makati City

Singapore

Factories

Brazil

Alphaville

China

TaiAn

Zhangjiagang

France

Charlieu

Moulines

Germany

Wilhelmshaven

India

Pune

Italy

Niella Tanaro

Portugal

Baltar

Fânzeres

Slovakia

Saris

USA

Manitowoc

Port Washington

Shady Grove

This document is non-contractual. Constant improvement and engineering progress make it necessary that we reserve the right to make specification, equipment, and price changes without notice. Illustrations shown may include optional equipment and accessories and may not include all standard equipment.



Grove Maniwoc National Crane Potain



Manitowoc 12000

Product Guide



Features

- 110 t (120 USt) capacity
- 397 mton-m (2,880 ft-kips) maximum load moment
- 70,1 m (230 ft) heavy-lift boom
- 82,3 m (270 ft) fixed jib on heavy-lift boom
- 94,5 m (310 ft) luffing jib on heavy-lift boom
- 247 kW (332 HP) engine



Contents

| | |
|---------------------------------|----|
| Specifications | 3 |
| Outline dimensions | 6 |
| Transport data | 10 |
| Crane assembly | 11 |
| Performance data | 12 |
| Load chart notes | 13 |
| Boom combinations | 14 |
| Main boom range / load charts | 16 |
| Fixed jib range / load charts | 18 |
| Luffing jib range / load charts | 21 |
| Clamshell | 25 |
| Manitowoc Crane Care | 26 |

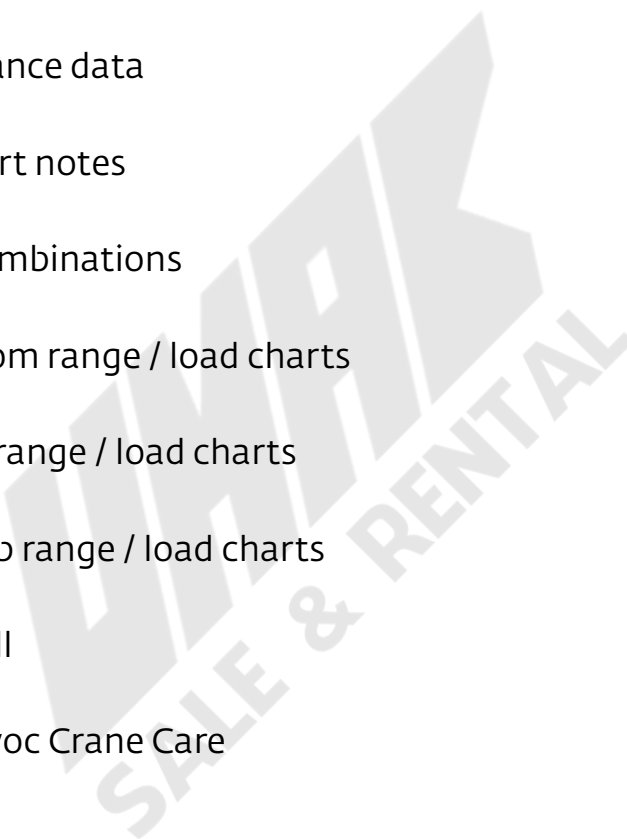



Specifications

Upperworks



Engine

Hino P11C-UN, 6 cylinder, water-cooled diesel, direct fuel injection with turbocharger, 247 kW (332 HP) at 2000 high-idle RPM. Maximum torque 1300 N•m (959 lb•ft) net at 1,500 rpm (SAE J 1349).

One diesel fuel tank, 400 liters (105 gallons) capacity.

Two 12 volt 136 AH capacity batteries, 24 volt system and 50 amp alternator.

All wiring harnesses and connectors are numbered for easier servicing. Machine is equipped with individual fused branch circuits.



Controls

Full-flow hydraulic control system for constant variable pressure to front and rear drums, boom hoist brakes and clutches. Controls respond instantly to the touch, delivering smooth function operation.

Relief valve pressures:

Load hoist, boom hoist

and propel system 315kg/cm² (4,480 psi)

Swing system 280 kg/cm², (3,980psi)

Control system 80 kg/cm² (1,140 psi)



Hydraulic system

All four variable displacement piston-type pumps are driven by a heavy-duty pump drive. One of these pumps is used in the right propel circuit and hook hoist circuit, and can accommodate an optional third circuit. Another is used in the left propel circuit and hook hoist circuit. The third variable displacement pump is used in the boom hoist circuit. The fourth variable displacement pump is used in the swing circuit. In addition, two gear pumps are used in the control system and auxiliary equipment, and two gear pumps serve the brake cooling system.

Maximum pressure rating . . . 325 kg/cm² (4,640 psi)

Load hoist, boom hoist and propel . . 2 Piston pumps

Boom Hoist 1 Piston pump

Swing 1 Piston pump

Control system and auxiliary 2 Gear pumps

Brake cooling system 2 Gear pumps

Reservoir capacity: 460 liter (121 US gallon).

Cooling: Oil-to-air heat exchanger (plate-fin type).

Filtration: Full-flow and bypass type with replaceable paper element.



Drums

Front and rear drums for load hoist powered by hydraulic variable displacement piston-type motors, driven through planetary reducers. Powered hoisting/lowering and free-fall operation is standard. Drum turn indicators for front and rear drums are also standard.

Brake & Clutches (compatible): Forced-circulation oil-cooled wet-type multi-disc brakes, each using positive and negative actuation. An external ratchet is fitted for locking the drums.

Drums: (front and rear) 613 mm (24.1") P.C.D. X 622 mm (24.5") wide drums, grooved for 26.0 mm wire rope.

Wire rope capacity:

Front drum 260 m (853 ft) working length

Rear drum 230 m (754 ft) working length

Storage length (each drum) 253 m (830')

Line speed: Single line on the first drum layer

Hoisting: 120m/min (394 ft/min)

Lowering: 120m/min (394 ft/min)

➤ **Optional third drum:** same dimensions and specifications as front and rear drums. Wire rope working length is 240 m (787').



Swing system

Swing unit: Powered by a hydraulic piston-type motor driving spur gears through planetary reducers, the swing system provides 360° rotation.

Swing brake: A spring-set, hydraulically released multiple-disc brake is internally fitted in swing motor.

Swing lock: 2 Position lock for transportation.

Rotating bed turntable: Single-row ball bearing with an integral internally cut swing gear.

Swing speed: 2.7 rpm



Boom support system

Single drum powered by a hydraulic axial piston motor through a planetary reducer.

Brake: A spring-set, hydraulically released multiple-disc brake is internally fitted in the boom hoist motor and



Specifications

operated through a counter-balance valve. An external ratchet is fitted for locking the drum.

Drum: Single drum, grooved for 20 mm dia. wire rope. Boom Hoist reeving is 10-part line.

Wire Rope Capacity:

Drum 155 m (508 ft) working length.

Line speed: Single line on the first drum layer

Hoisting: 48m/min (157 ft/min)

Lowering: 48m/min (157 ft/min)



Gantry

This high folding type gantry is fitted with a sheave frame for boom hoist reeving. It provides full up, full down positions.



Counterweight

| Qty. | Item | Unit weight | | Total weight | |
|----------------------------|-----------------|---------------|---------------|--------------|--------|
| | | kg | lb | kg | lb |
| 1 | Counterweight A | 10 000 | 22,050 | 10 000 | 22,050 |
| 2 | Counterweight B | 7 000 | 15,435 | 14 000 | 30,870 |
| 1 | Counterweight C | 10 000 | 22,050 | 10 000 | 22,050 |
| Counterweight Total | | 34 000 | 74,970 | | |



Operator's cab

Totally enclosed, full vision cab fitted with tinted safety glass. A fully adjustable, highbacked seat with arm rests permits operators to set their ideal working position. Side mounted console for auxiliary controls and instruments. An air conditioner, a signal horn, cigarette lighter, windshield wiper and inspection lamp socket are standard features.

Controls

In front of operator are the foot pedals for front, rear and third drum (option) brakes and foot throttle pedal. At operator's right side are the travel (propel) control levers and the function lock lever. To the operator's right front are the boom hoist control lever, front and rear winch control levers and the free-fall select switches for the front and rear winches and drum turn indicators (front/rear drum). To the operators left front are the swing control lever and third drum (option) control lever. To the operator's left are the crawler extend/retract lever and the positive swing lock. The left-hand console contains switches for the anti-two-block/boom overhoist. Directly in front of the console are the drum pawl lock for boom, front, rear and third drum (option) and the engine ignition key. The swing parking brake and signal horn are mounted on the swing control lever.

Gauges

Fuel gauge, engine water temperature gauge, hour meter and tachometer are located on the monitor display.

Warning display

All potential warnings, including battery charge, engine oil pressure, air cleaner, engine oil filter, control main pressure, and hydraulic oil temperature will appear on the monitor display when a fault occurs.

Safety device

Function lock lever, anti-two-block, boom over hoist limit switch, boom angle indicator, signal horn, boom hoist drum lock, front and rear drum lock, swing lock, swing alarm (buzzer and lamps), boom backstops and load moment indicator.

Lowerworks



Carbody

The durable carbody features steel welded construction with extendible axles.



Crawlers

Crawler assemblies can be hydraulically extended for wide-track operation or retracted for transportation. Crawler belt tension adjusted with hydraulic jack and maintained by shims between idler block and frame.

Crawler drive

The independent hydraulic propel drive is built into each crawler side frame. Each drive consists of a hydraulic motor driving a propel sprocket through a planetary gearbox. The hydraulic motor and gearbox are built into the crawler side frame within the shoe width. The track rollers are sealed for maintenance-free operation.

Crawler brakes

Spring set, hydraulically released, multiple disc-type parking brakes are built into each propel drive.

Steering mechanism

The hydraulic propel system provides both skid steering (driving one track only) and counter-rotating steering (driving each track in opposite direction) and differential track speed.

Crawler shoes

66 shoes per side, 914 mm (36") wide each crawler.

Travel speed

(High/Low) 1.4/1.0 km/h (0.87/0.62 mph)



Specifications

Attachments



Boom

Welded lattice construction using tubular, high-tensile steel chords with pin connections between sections. Boom tip is open throat construction. Two idler sheaves and four point sheaves are standard.

Basic boom length 15,24 m (50') consists of the boom butt section 7,62 m (25' 0") and boom top section 7,62 m (25' 0").

Optional boom inserts are available to provide extension capabilities. They also have welded lattice construction with tubular, high-tensile steel chords and pin connections on each one of 3,0 m (10'), 6,1 m (20'), 12,2 m (40') inserts.

Maximum total length of boom 70,1 m (230').



Fixed jib

The optional fixed jib employs welded lattice construction with tubular, high-tensile steel chords with pin connections between sections.

Basic jib length 9,14 m (30') consists of jib butt section 4,57 m (15') and jib top section 4,57 m (15').

Optional jib boom inserts of 3,0 m (10'), 6,1 m (20') are available for extension capabilities up to 21,3 m (70').

Maximum total length of boom and jib 61,0 m (200') + 21,3 m (70') is 82,3 m (270').



Luffing jib

Optional: Components to make up 18,3 m (60') basic luffing boom including 7,62 m (25') butt, 9,14 m (30') special luffing boom insert (with idler sheave), 1,5 m (5') top, boom strut assembly, jib strut assembly, jib stop assembly, strut backstops, backstay pendants with sheaves, mounting parts and LMI hardware.

Optional: 3,1 m (10'), 6,1 m (20'), and 12,2 m (40') luffing boom inserts. Utilize optional boom inserts to make up to 45,7 m (150') of luffing boom.

Optional: 18,3 m (60') basic luffing jib assembly including 5,8 m (19') luffing jib butt, 6,1 m (20') luffing jib insert, 6,4 m (21') luffing jib top, 6,4 m (21') front strut assembly, 5,3 m (17' 5") rear strut assembly, and luffing jib point roller assembly (single sheave) which is required during erection of the jib.

Maximum 51,8 m (170') jib length for 42,7 m (140') boom length and maximum 30,4 m (100') jib length for 45,7 m (150') boom length.

Note: Luffing boom utilizes the liftcrane boom inserts (except for the 30' special luffing boom insert). Also, the third drum and wire rope must be ordered with luffing jib attachment.

Tools and accessories

A set of tools and accessories are furnished.

Optional equipment

- Optional: Blocks and Hooks each with roller bearing sheaves grooved for 26.0 mm diameter wire rope, and roller bearing swivel with hook latch.
- 12 t ball hook, 456 kg wedge socket for 26 mm wire rope. (15 USt ball hook, 1,310 lb wedge socket for 26 mm wire rope.)
- 35 t hook block, 700 kg with one 622 mm Nominal O.D. roller bearing sheave. (40 USt hook block, 1,881 lb with one 24" Nominal O.D. roller bearing sheaves.)
- 70 t hook block, 900 kg, three 622 mm Nominal O.D. roller bearing bearing sheave. (90 USt hook block, 4,060 lb, with three 24" Nominal O.D. roller bearing sheaves.)
- 110 t hook block, 1 700 kg, with five 622 mm Nominal O.D. roller bearing sheaves. (120 USt hook block, 3,760 lb with five 24" Nominal O.D. roller bearing sheaves.)
- Optional: Detachable upper boom point with one 575 mm (22.6") Nominal outer diameter roller bearing steel sheave grooved for 26mm rope for liftcrane.

Travel kit
Custom color

Working weight

Approximately 99,000 kg (218,000 lb) including upperworks and lowerworks, full upper counterweights and 15,2 m (50') basic boom.

Ground pressure

Approximately 92.9 kPa (13.5 psi) with basic boom and no load.

Gradeability

With basic boom: 30%.



Outline dimensions

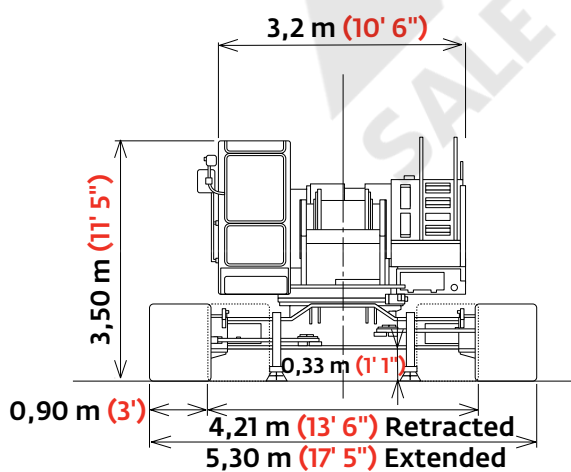
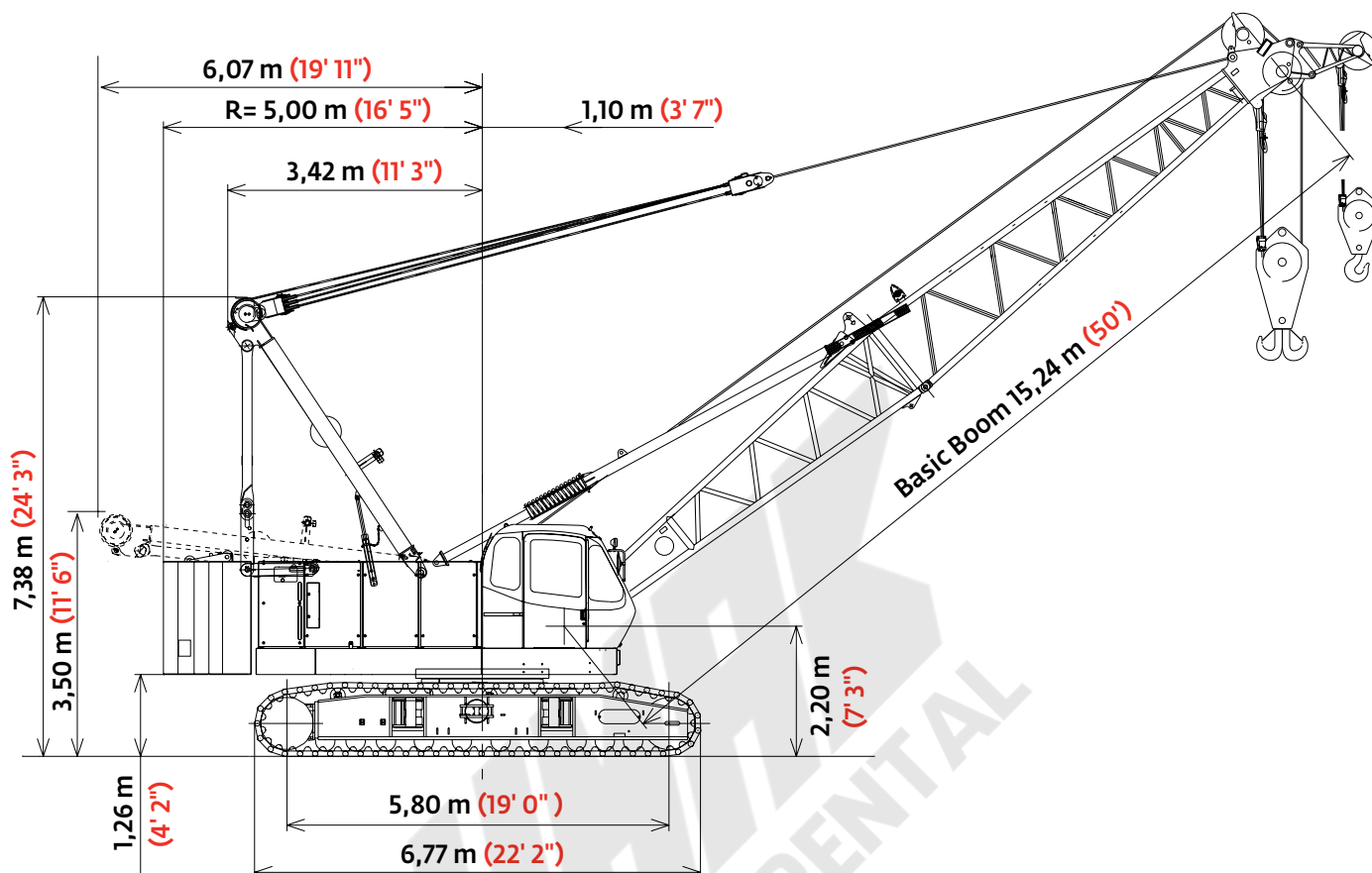



Outline dimensions

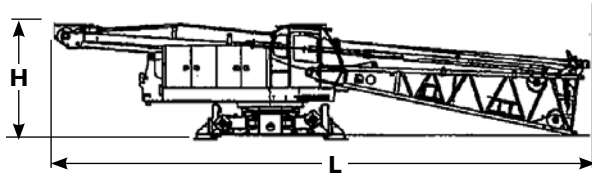

Upperworks without crawlers x 1

| | | |
|--------|-----------|-----------|
| Length | 15,12 m | 49' 7" |
| Width | 3,24 m | 10' 8" |
| Height | 3,15 m | 10' 4" |
| Weight | 42 661 kg | 94,052 lb |

Note: Weight includes base machine, gantry, maximum hoist and whip lines on drums, boom butt, full hydraulic fluid reservoir, and one-third tank of fuel.

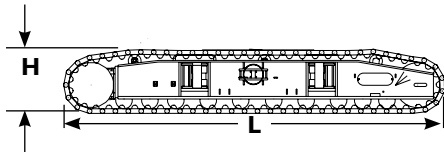

Crawlers x 2

| | | |
|--------|-----------|-----------|
| Length | 6,77 m | 22' 3" |
| Width | 0,90 m | 3' 0" |
| Height | 1,15 m | 3' 9" |
| Weight | 11 830 kg | 26,085 lb |

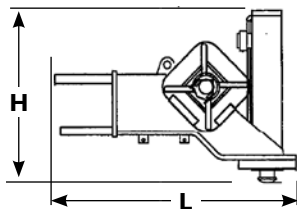

Hydraulic jack (if removed) x 4

| | | |
|--------|--------|--------|
| Length | 1,36 m | 4' 5" |
| Width | 0,32 m | 1' 1" |
| Height | 0,96 m | 3' 2" |
| Weight | 430 kg | 950 lb |

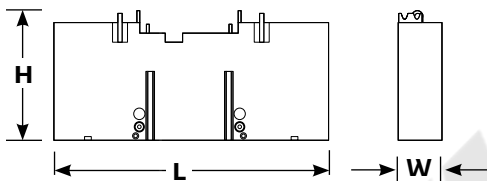

Upper counterweight A x 1

| | | |
|--------|-----------|-----------|
| Length | 3,20 m | 10' 5" |
| Width | 0,58 m | 1' 11" |
| Height | 1,94 m | 6' 4" |
| Weight | 10 000 kg | 22,050 lb |

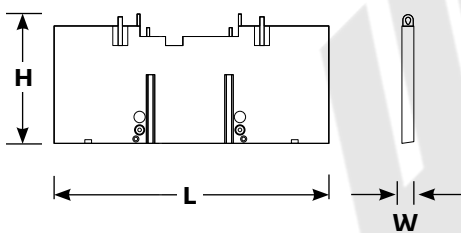

Upper counterweight B x 2

| | | |
|--------|----------|-----------|
| Length | 3,20 m | 10' 5" |
| Width | 0,49 m | 1' 7" |
| Height | 1,92 m | 6' 3" |
| Weight | 7 000 kg | 15,435 lb |

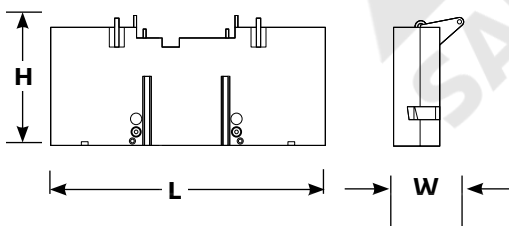

Upper counterweight C x 1

| | | |
|--------|-----------|-----------|
| Length | 3,20 m | 10' 5" |
| Width | 0,69 m | 2' 3" |
| Height | 1,92 m | 6' 3" |
| Weight | 10 000 kg | 22,050 lb |

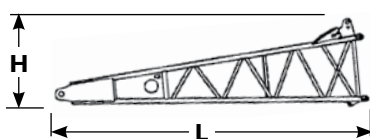

Optional 3rd drum and wire rope x 1

| | | |
|--------|----------|----------|
| Weight | 2 660 kg | 5,865 lb |
|--------|----------|----------|

Boom butt 7,6 m (25 ft) x 1

| | | |
|--------|----------|----------|
| Length | 7,79 m | 26' 3" |
| Width | 1,68 m | 5' 6" |
| Height | 2,06 m | 6' 9" |
| Weight | 2 110 kg | 4,652 lb |

Option



Outline dimensions

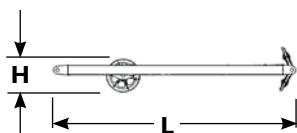
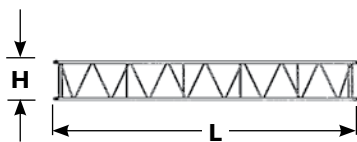
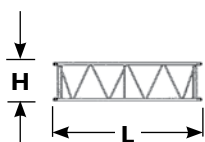
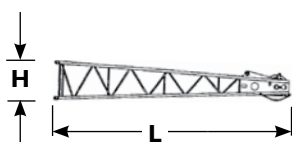
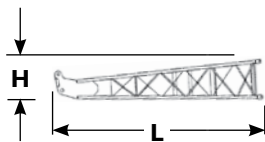
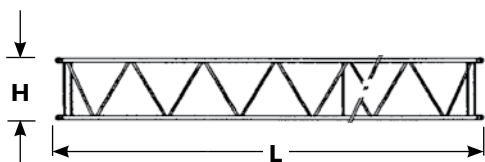
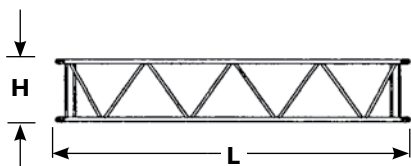
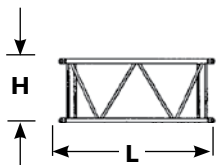
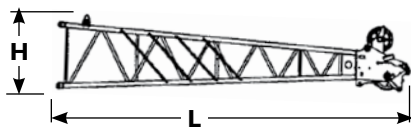

| Boom top 7,6 m (25 ft) | | x 1 |
|------------------------|----------|----------|
| Length | 8,32 m | 27' 4" |
| Width | 1,68 m | 5' 6" |
| Height | 1,69 m | 5' 7" |
| Weight | 1 525 kg | 3,362 lb |

| Boom insert 3,0 m (10 ft) | | x 1,2 |
|---------------------------|--------|--------|
| Length | 3,17 m | 10' 5" |
| Width | 1,68 m | 5' 6" |
| Height | 1,69 m | 5' 7" |
| Weight | 380 kg | 838 lb |

| Boom insert 6,1 m (20 ft) | | x 1,2 |
|---------------------------|--------|----------|
| Length | 6,22 m | 20' 5" |
| Width | 1,68 m | 5' 6" |
| Height | 1,69 m | 5' 7" |
| Weight | 655 kg | 1,445 lb |

| Boom insert 12,2 m (40 ft) | | x 1,2,3 |
|----------------------------|----------|----------|
| Length | 12,31 m | 40' 5" |
| Width | 1,68 m | 5' 6" |
| Height | 1,69 m | 5' 7" |
| Weight | 1 195 kg | 2,635 lb |

Note: Use of one "A" type insert with lug required for any boom combinations that require a 12,2 m (40') insert.

| Fixed jib butt | | x 1 |
|----------------|--------|--------|
| Length | 4,81 m | 15' 9" |
| Width | 0,80 m | 2' 8" |
| Height | 0,80 m | 2' 8" |
| Weight | 200 kg | 440 lb |

| Fixed jib top | | x 1 |
|---------------|--------|--------|
| Length | 4,91 m | 16' 1" |
| Width | 0,80 m | 2' 8" |
| Height | 0,80 m | 2' 8" |
| Weight | 280 kg | 617 lb |

| Fixed jib insert 3,0 m (10 ft) | | x 1,2 |
|--------------------------------|--------|--------|
| Length | 3,12 m | 10' 3" |
| Width | 0,80 m | 2' 8" |
| Height | 0,80 m | 2' 8" |
| Weight | 100 kg | 220 lb |

| Fixed jib insert 6,1 (20 ft) | | x 1,2 |
|------------------------------|--------|--------|
| Length | 6,16 m | 20' 3" |
| Width | 0,80 m | 2' 8" |
| Height | 0,80 m | 2' 8" |
| Weight | 180 kg | 395 lb |

| Fixed jib strut | | x 1 |
|-----------------|--------|---------|
| Length | 3,62 m | 11' 11" |
| Height | 0,62 m | 2' 0" |
| Weight | 250 kg | 550 lb |

Option



Outline dimensions

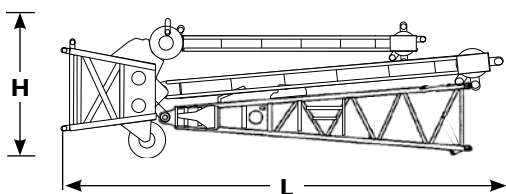
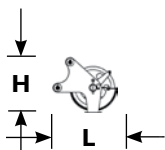
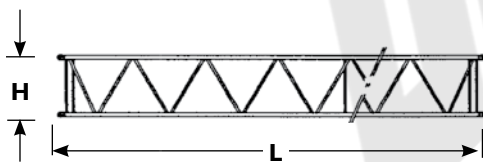
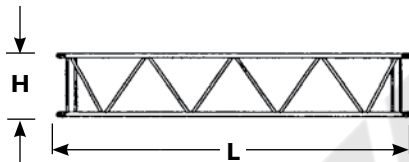
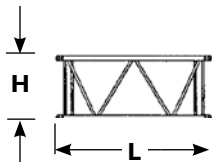
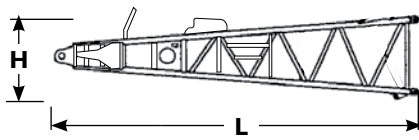
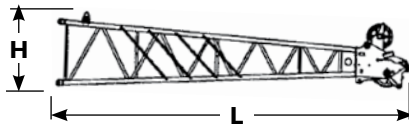
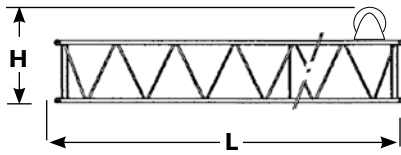

| Special luffing boom insert 9,1 m (30 ft) x1 | | |
|---|---------|----------|
| Length | 9,27 m | 30' 5" |
| Width | 1,68 m | 5' 6" |
| Height | 2,41 m | 7' 11" |
| Weight | 1160 kg | 2,558 lb |

| Luffing jib top x1 | | |
|--------------------|---------|----------|
| Length | 6,91 m | 22' 8" |
| Width | 1,50 m | 4' 11" |
| Height | 1,48 m | 4' 10" |
| Weight | 1170 kg | 2,580 lb |

| Luffing jib butt x1 | | |
|---------------------|--------|----------|
| Length | 5,97 m | 19' 7" |
| Width | 1,49 m | 4' 11" |
| Height | 1,32 m | 4' 4" |
| Weight | 836 kg | 1,903 lb |

| Luffing jib insert 3,0 m (10 ft) x1,2 | | |
|---------------------------------------|--------|--------|
| Length | 3,16 m | 10' 5" |
| Width | 1,49 m | 4' 11" |
| Height | 1,29 m | 4' 3" |
| Weight | 310 kg | 684 lb |

| Luffing jib insert 6,1 m (20 ft) x1,2 | | |
|---------------------------------------|--------|----------|
| Length | 6,21 m | 20' 5" |
| Width | 1,49 m | 4' 11" |
| Height | 1,29 m | 4' 3" |
| Weight | 540 kg | 1,147 lb |

| Luffing jib insert 12,2 m (40 ft) x1,2,3 | | |
|--|---------|----------|
| Length | 12,31 m | 40' 4" |
| Width | 1,49 m | 4' 11" |
| Height | 1,29 m | 4' 3" |
| Weight | 960 kg | 2,117 lb |

| Luffing jib point roller assembly x1 | | |
|--------------------------------------|--------|--------|
| Length | 1,01 m | 3' 4" |
| Width | 0,89 m | 2' 11" |
| Height | 0,91 m | 3' 0" |
| Weight | 380 kg | 838 lb |

| Luffing boom top assembly (Shipping style) x1 | | |
|--|----------|----------|
| Length | 8,19 m | 26' 10" |
| Height | 2,65 m | 8' 8" |
| Weight | 3 580 kg | 7,895 lb |

Option



Transport data

Trailer load out summary

12000 fixed jib 21,3 m (70 ft) on 12000 boom 70,1 m (230 ft)

| Item | Weight each item kg (lb) | Quantity on trailer load # | | | | | |
|--|--------------------------------|-------------------------------|--------------------|--------------------|-------------------|--------------------|--------------------|
| | | 1 | 2 | 3 | 4 | 5 | 6 |
| 12000 basic crane with crawlers removed | 42 661 (94,052) | 1 | | | | | |
| Crawler frame | 11 832 (26,085) | | 1 | | | | |
| Crawler frame | 11 832 (26,085) | | | 1 | | | |
| Counterweight A | 10 000 (22,050) | | | | | 1 | |
| Counterweight B | 7 000 (15,435) | | | | 1 | | |
| Counterweight B | 7 000 (15,435) | | | | | 1 | |
| Counterweight C | 10 000 (22,050) | | | | | | 1 |
| 12,2 m (40 ft) boom insert, pendants | 1 195 (2,635) | | 1 | | | | |
| 12,2 m (40 ft) boom insert, pendants | 1 195 (2,635) | | | 1 | | | |
| 12,2 m (40 ft) boom insert, pendants | 1 195 (2,635) | | | | 1 | | |
| 6,1 m (20 ft) boom insert, pendants | 655 (1,445) | | | | | 1 | |
| 6,1 m (20 ft) boom insert, pendants | 655 (1,445) | | | | | | 1 |
| 3,0 m (10 ft) boom insert, pendants | 380 (838) | | 1 | | | | |
| 3,0 m (10 ft) boom insert, pendants | 380 (838) | | | | | 1 | |
| Standard boom top 7,6 m (25 ft) | 1,525 (3,362) | | | | | | 1 |
| Upper boom point | 501 (1,105) | | | 1 | | | |
| 4,6 m (15 ft) fixed jib top | 280 (617) | | | | 1 | | |
| 4,6 m (15 ft) fixed jib butt | 200 (440) | | | | | | 1 |
| 6,1 m (20 ft) fixed jib insert | 180 (395) | | | | 1 | | |
| 6,1 m (20 ft) fixed jib insert | 180 (395) | | | | | | 1 |
| Approximate total Shipping weight kg (lb) | | 42 661 (94,052) | 13 407 (29,558) | 13 528 (29,825) | 8 655 (19,082) | 18 035 (39,768) | 12 560 (27,692) |
| | | 1 | 2 | 3 | 4 | 5 | 6 |



Crane assembly

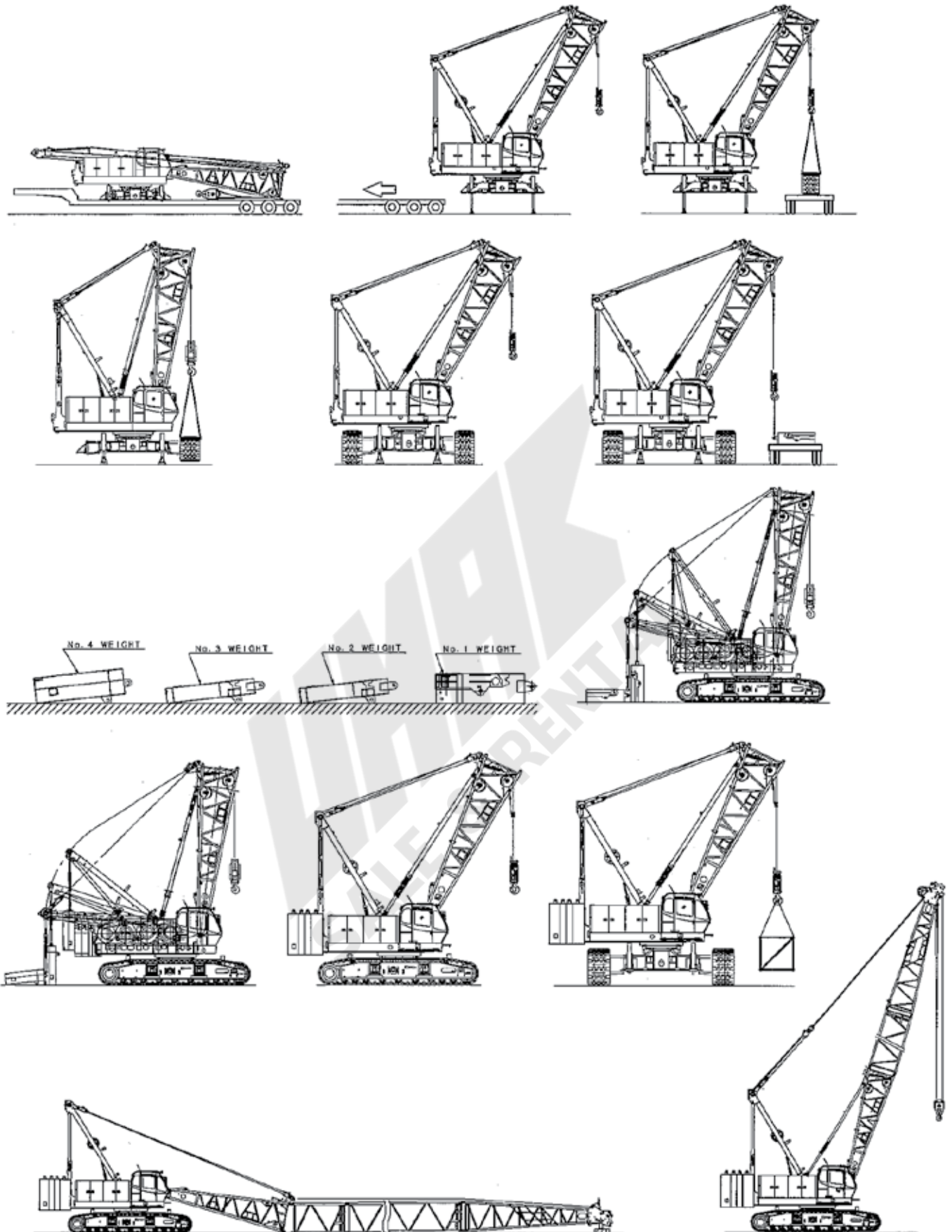



Performance data

| Line pull | | |
|-------------------|----------------------------|-------------------------------|
| | Rated line pull kg (lb) | *Maximum line pull kg (lb) |
| Front drum | 11 400 (25,100) | 21 180 (46,700) |
| Rear drum | 11 400 (25,100) | 21 180 (46,700) |
| Optional 3rd drum | 11 400 (25,100) | 21 180 (46,700) |

* Maximum line pull is not based on wire rope strength.

| Wire rope specifications | | | | |
|--------------------------|-------------------------|----------------|-----------------------------|---------------------------------|
| Use | Specs | Diameter mm | Working length m (ft) | Breaking strength kg (lb) |
| Front drum | IWRC 6 X Fi (29) C/O | 26,0 | 260 (853) | 54 431 (120,000) |
| Rear drum | IWRC 6 X Fi (29) C/O | 26,0 | 230 (754) | 54 431 (120,000) |
| Boom hoist drum | IWRC 6 X WS (31) C/O | 20,0 | 155 (508) | 33 430 (73,700) |

| Front and rear winch performance (optional: third winch) | | | | | | |
|--|------------------------------|--------------|--------------|--------------|--------------|--------------|
| Layer | Line speed m/min (ft/min) | | | | | |
| | 1 | 2 | 3 | 4 | 5 | 6 |
| Single line pull kg (lb) | | | | | | |
| 0 (0) | 120 (394) | 129 (422) | 137 (450) | 146 (479) | 155 (505) | 163 (535) |
| 2 268 (5,000) | 118 (387) | 126 (415) | 135 (443) | 143 (471) | 152 (499) | 160 (526) |
| 4 536 (10,000) | 108 (353) | 108 (353) | 108 (353) | 108 (353) | 108 (353) | 108 (353) |
| 6 804 (15,000) | 72 (235) | 72 (235) | 72 (235) | 72 (235) | 72 (235) | 72 (235) |
| 9 072 (20,000) | 52 (117) | 52 (117) | 52 (117) | 52 (117) | 52 (117) | 52 (117) |
| 11 340 (25,000) | 43 (141) | 43 (141) | 43 (141) | 43 (141) | 43 (141) | 43 (141) |
| 13 608 (30,000) | 36 (118) | 36 (118) | 36 (119) | 37 (121) | 37 (122) | 37 (123) |
| 15 876 (35,000) | 31 (103) | 32 (104) | 32 (105) | 32 (105) | – | – |
| 18 144 (40,000) | 28 (92) | 28 (92) | – | – | – | – |

NOTE: Line speeds and line pull based on single line.
Line pulls are not based on wire rope strength.



Load chart notes

- Rated loads included in the charts are the maximum allowable freely suspended loads at a given boom length, boom angle and load radius, and have been determined for the machine standing level on firm supporting surface under ideal operating conditions. The user must limit or de-rate rated loads to allow for adverse conditions (such as soft or uneven ground, out-of-level conditions, wind, side loads, pendulum action, jerking or sudden stopping of loads, inexperience of personnel, multiple machine lifts, and traveling with a load).
- Capacities do not exceed 75% of minimum tipping loads. Capacities based on factors other than machine stability such as structural competence are shown by asterisk * in the charts located in the operator's crane cab.
- The machine must be reeved and set-up as stated in the operation manual and all the instruction manuals. If these manuals are missing, obtain replacements. Boom backstops are required for all boom lengths. Gantry must be in the fully raised position for all operations. Crawlers must be fully extended and be locked in position. The crane must be leveled to within 1% on a firm supporting surface.
- Do not attempt to lift where no radius or load is listed as crane may tip or collapse.
- Attempting to lift more than rated loads may cause machine to tip or collapse. Do not tip machine to determine capacity.
- Weight of hooks, hook blocks, slings and other lifting devices are a part of the total load. Their total weight must be subtracted from the rated load to obtain the weight that can be lifted.
- When lifting over boom point with jib or upper boom point installed, rated loads for the boom must be deducted as shown below.

| Jib length m (ft) | Upper boom point | 9,1 (30) | 12,2 (40) | 15,2 (50) | 18,3 (60) | 21,3 (70) |
|-------------------|------------------|--------------|--------------|--------------|--------------|--------------|
| Deduct kg (lb) | 318 (700) | 1100 (2,400) | 1500 (3,200) | 2000 (4,200) | 2400 (5,200) | 2900 (6,200) |

When lifting over luffing jib point with luffing jib roller assembly or pin connected boom point sheave (on the luffing boom top) attached, rated loads for the jib and sheave must be deducted as shown below.

| | Luffing jib point roller | Pin connected boom point sheave |
|----------------|--------------------------|---------------------------------|
| Deduct kg (lb) | 386 (850) | 218 (480) |

- The total load that can be lifted by the fixed jib is limited by rated jib loads. The total load that can be lifted with the upper boom point is limited by rated upper boom point loads.
- Boom lengths for fixed jib mounting are 27,4 m (90 ft) to 61,0 m (200 ft).
- The total load that can be lifted by the upper boom point is: the rated load for the luffing jib (without upper boom point installed) minus 386 kg (850 lb);

however, the upper boom point rated load should not exceed 11 300 kg (25,000 lb).

- An upper boom point cannot be used on a 70,1 m (230 ft) boom length.
- The boom should be erected over the front of the crawlers, not laterally.
- Least stable position is over the side.
- Maximum hoist load for number of reeving parts of line for hoist rope.

Maximum load for main boom

| No. of parts of line | 1 | 2 | 3 | 4 | 5 |
|-----------------------|-----------------|-----------------|-----------------|------------------|------------------|
| Maximum loads kg (lb) | 11 300 (25,000) | 22 600 (50,000) | 33 900 (75,000) | 45 200 (100,000) | 56 500 (125,000) |

| No. of parts of line | 6 | 7 | 8 | 9 | 10 |
|-----------------------|------------------|------------------|------------------|-------------------|-------------------|
| Maximum loads kg (lb) | 67 800 (150,000) | 79 100 (175,000) | 90 400 (200,000) | 101 700 (225,000) | 110 000 (240,000) |

Maximum load for luffing jib

| No. of parts of line | 1 | 2 | 3 | 4 |
|-----------------------|-----------------|-----------------|-----------------|-----------------|
| Maximum loads kg (lb) | 11 300 (25,000) | 22 600 (50,000) | 33 900 (75,000) | 36 200 (80,000) |

Maximum load for fixed jib

| No. of parts of line | 1 |
|-----------------------|-----------------|
| Maximum loads kg (lb) | 10 800 (24,000) |

Maximum load for upper boom point (on liftcrane boom)

| No. of parts of line | 1 | 2 |
|-----------------------|-----------------|-----------------|
| Maximum loads kg (lb) | 11 300 (25,000) | 22 600 (50,000) |

Maximum load for upper boom point (on luffing jib)

| No. of parts of line | 1 |
|-----------------------|-----------------|
| Maximum loads kg (lb) | 11 300 (25,000) |

Minimum weight of hook block required for lowering. (Luffing jib use)

| No. of parts of line | 1 | 2 | 3 | 4 |
|------------------------|-----------|-------------|-------------|-------------|
| Maximum weight kg (lb) | 272 (600) | 544 (1,200) | 680 (1,500) | 800 (1,800) |

- Lifting capacities listed apply only to the machine as originally manufactured for and supplied by Manitowoc Cranes, Inc. Modifications to this machine or use of equipment other than that specified can reduce operating capacity.
- Designed and rated to comply with ANSI Code B30.5.

Operation of this equipment in excess of rated loads or disregard of instruction voids the warranty.



Boom combinations

No. 12000 heavy-lift boom combinations

| Boom length m (ft) | Boom inserts | | |
|-----------------------|------------------|------------------|-------------------|
| | 3,1 m (10 ft) | 6,1 m (20 ft) | 12,2 m (40 ft) |
| 15,2 (50) | – | – | – |
| 18,3 (60) | 1 | – | – |
| 21,3 (70) | 2 | 1 | – |
| 24,4 (80) | 1 | 1 | – |
| 27,4 (90) | 2 | 1 | – |
| 30,5 (100) | 1 | 2 | – |
| 33,5 (110) | 2 | 2 | – |
| 36,6 (120) | 1 | 1 | 1* |
| 39,6 (130) | 2 | 1 | 1* |
| 42,7 (140) | 1 | 2 | 1* |
| 45,7 (150) | 2 | 2 | 1* |
| 48,8 (160) | 1 | 1 | 2* |
| 51,8 (170) | 2 | 1 | 2* |
| 54,9 (180) | 1 | 2 | 2* |
| 57,9 (190) | 2 | 2 | 2* |
| 61,0 (200) | 1 | 1 | 3* |
| 64,0 (210) | 2 | 1 | 3* |
| 67,0 (220) | 1 | 2 | 3* |
| 70,1 (230) | 2 | 2 | 3* |

* NOTE: One 40 ft (12,2 m) boom insert with lug 40A is required for fixed jib. When no jib is installed a 40 ft (12,2 m) boom can be used instead of 40A.

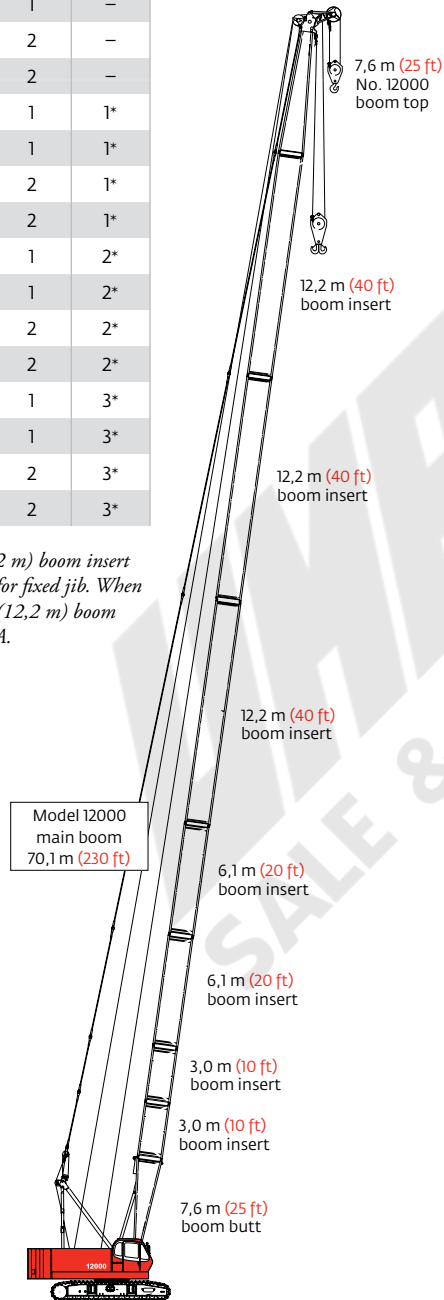

**Model 12000
Main boom
70,1 m (230 ft)**

No. 12000 fixed jib combinations

| Fixed jib length m (ft) | Fixed jib inserts | |
|----------------------------|-------------------|------------------|
| | 3,1 m (10 ft) | 6,1 m (20 ft) |
| 9,1 (30) | – | – |
| 12,2 (40) | 1 | – |
| 15,2 (50) | – | 1 |
| 18,3 (60) | 1 | 1 |
| 21,3 (70) | – | 2 |

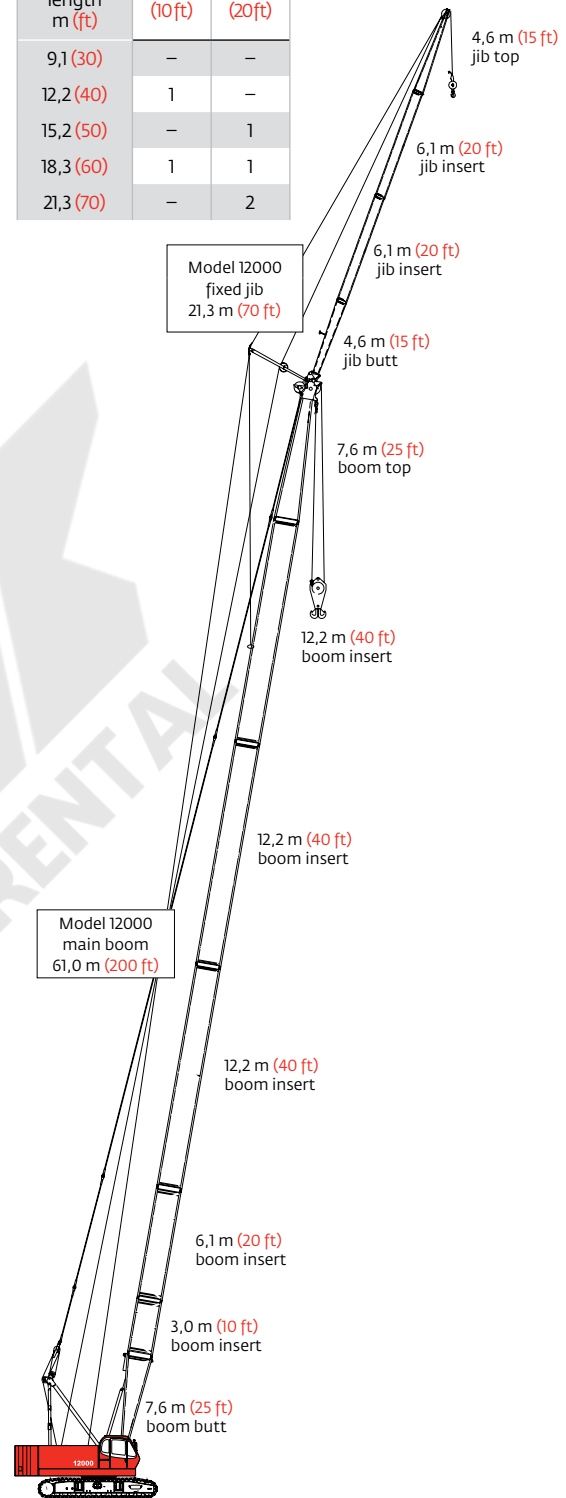

**Model 12000
Fixed jib on main boom
82,3 m (270 ft)**



Boom combinations

No. 12000 luffing jib combinations

| Boom length m (ft) | Boom inserts | | |
|-----------------------|-----------------|-----------------|------------------|
| | 3,0m (10 ft) | 6,1m (20 ft) | 12,2m (40 ft) |
| 18,3 (60) | – | – | – |
| 21,3 (70) | 1 | – | – |
| 24,4 (80) | 2 | – | – |
| 27,4 (90) | 1 | 1 | – |
| 30,5 (100) | 2 | 1 | – |
| 33,5 (110) | 1 | – | 1 |
| 36,6 (120) | 2 | – | 1 |
| 39,6 (130) | 1 | 1 | 1 |
| 42,7 (140) | 2 | 1 | 1 |
| 45,7 (150) | 1 | – | 2 |
| 48,8 (160) | 2 | – | 2 |
| 51,8 (170) | 1 | 1 | 2 |

No. 12000 luffing boom combinations

| Boom length m (ft) | Boom inserts | | | |
|-----------------------|-----------------|-----------------|-----------------|------------------|
| | 3,0m (10 ft) | 6,1m (20 ft) | 9,1m (30 ft) | 12,2m (40 ft) |
| 18,3 (60) | – | – | 1* | – |
| 21,3 (70) | 1 | – | 1* | – |
| 24,3 (80) | 2 | – | 1* | – |
| 27,4 (90) | 1 | 1 | 1* | – |
| 30,5 (100) | 2 | 1 | 1* | – |
| 33,5 (110) | 1 | 2 | 1* | – |
| 36,6 (120) | 2 | 2 | 1* | – |
| 39,6 (130) | 1 | 1 | 1* | 1 |
| 42,7 (140) | 2 | 1 | 1* | 1 |
| 45,7 (150) | 1 | 2 | 1* | 1 |

NOTE: One 9,14 m (30') special luffing boom insert is required for luffing boom.

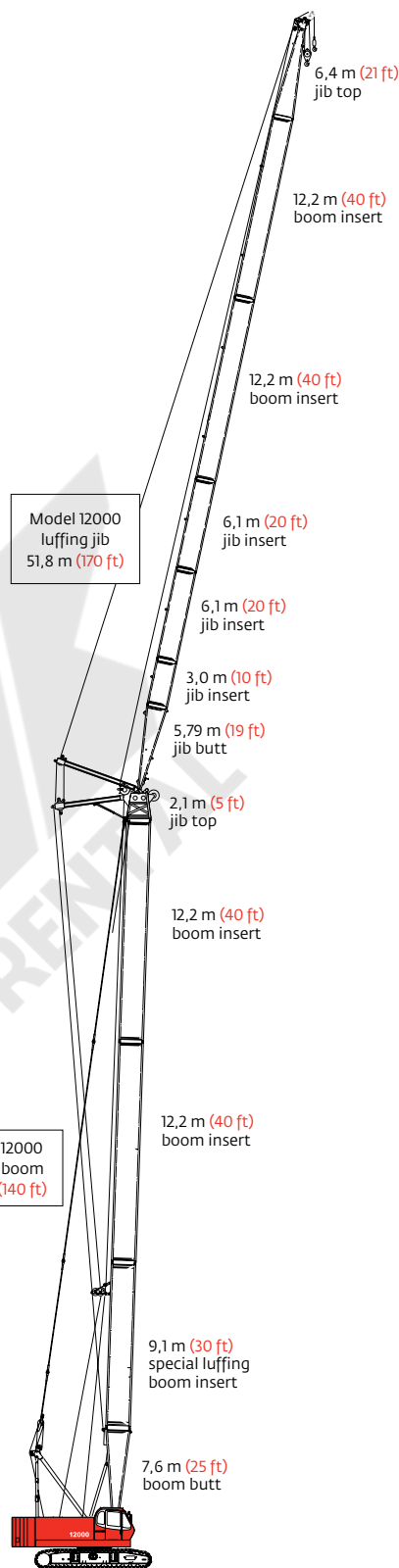

Model 12000
Luffing jib on luffing boom
94,5 m (310 ft)



Heavy-lift boom range diagram

No. 12000 main boom

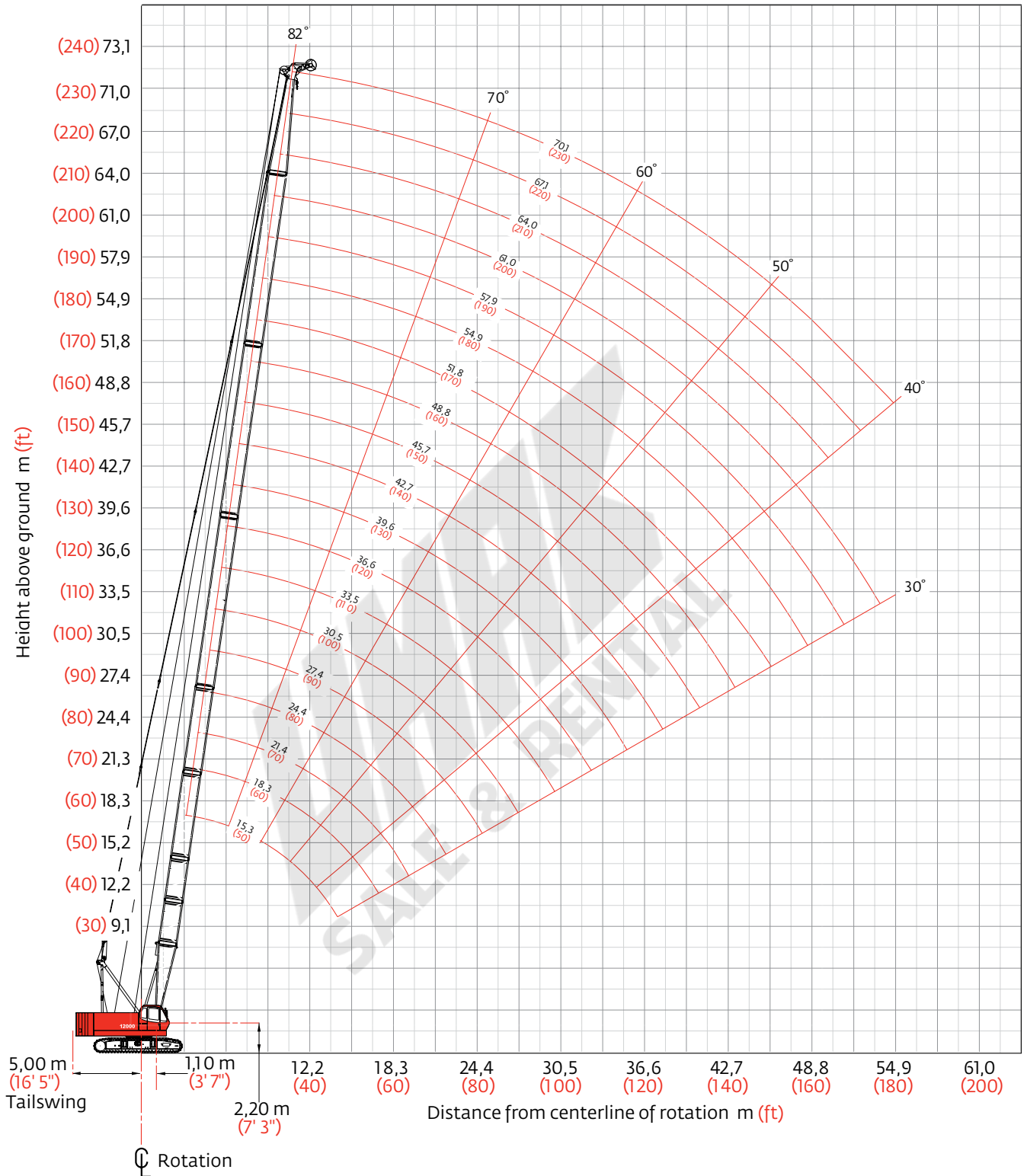



Heavy-lift boom load charts

Model 12000 liftcrane boom capacities - No. 12000 main boom

34 000 kg (75,000 lb) upper counterweight

360° Rating

kg (lb) x 1 000

| Boom m (ft) | 15,2 (50) | 18,3 (60) | 21,3 (70) | 24,4 (80) | 27,4 (90) | 30,5 (100) | 33,5 (110) | 36,6 (120) | 39,6 (130) | 42,7 (140) | 45,7 (150) | 48,8 (160) | 51,8 (170) | 54,9 (180) | 57,9 (190) | 61,0 (200) | 64,0 (210) | 67,1 (220) | 70,1 (230) |
|-------------------|------------------|-----------------|-----------------|-----------------|-----------------|-----------------|-----------------|-----------------|----------------|----------------|----------------|----------------|----------------|----------------|----------------|----------------|----------------|----------------|----------------|
| Radius | | | | | | | | | | | | | | | | | | | |
| 3,6 (12) | 110,0 (240.0) | | | | | | | | | | | | | | | | | | |
| 4,0 (14) | 99,1 (206.0) | — (204.0) | | | | | | | | | | | | | | | | | |
| 4,5 (16) | 88,4 (177.0) | 87,6 (177.0) | 86,2 (177.0) | | | | | | | | | | | | | | | | |
| 5,5 (18) | 68,0 (150.0) | 67,9 (150.0) | 67,9 (150.0) | 68,0 (150.0) | 67,9 (150.0) | | | | | | | | | | | | | | |
| 6,0 (20) | 62,0 (135.0) | 61,9 (135.0) | 61,9 (135.0) | 62,0 (135.0) | 61,9 (135.0) | 61,9 (135.0) | | | | | | | | | | | | | |
| 7,0 (24) | 53,6 (111.9) | 53,6 (111.7) | 53,6 (111.7) | 53,6 (111.5) | 53,6 (111.5) | 53,1 (111.3) | 53,0 (111.3) | 53,3 (111.1) | — (100.0) | | | | | | | | | | |
| 8,0 (28) | 44,5 (89.5) | 44,3 (89.2) | 44,3 (89.0) | 44,3 (88.8) | 44,3 (88.8) | 44,2 (88.6) | 44,1 (88.4) | 44,1 (88.4) | 44,0 (88.1) | 43,9 (87.9) | — (87.7) | | | | | | | | |
| 10,0 (34) | 32,8 (68.3) | 32,2 (68.1) | 32,2 (67.9) | 32,2 (67.4) | 32,2 (67.4) | 32,1 (67.2) | 32,0 (67.0) | 32,0 (67.0) | 31,9 (66.7) | 31,8 (66.5) | 31,7 (66.3) | 31,7 (66.3) | 31,6 (66.1) | 31,5 (65.9) | 30,0 (65.4) | | | | |
| 12,0 (40) | 25,6 (55.1) | 25,6 (54.6) | 25,3 (54.4) | 25,3 (54.2) | 24,6 (54.0) | 24,9 (53.7) | 24,8 (53.5) | 24,8 (53.5) | 24,7 (53.3) | 24,6 (53.1) | 24,4 (52.6) | 24,5 (52.9) | 24,3 (52.4) | 24,2 (52.2) | 24,1 (52.0) | 22,6 (50.0) | 22,6 (50.0) | 21,3 (46.7) | 19,5 (42.7) |
| 14,0 (45) | — (47.1) | 20,5 (46.7) | 20,5 (46.5) | 20,5 (46.2) | 20,5 (46.0) | 20,3 (45.8) | 20,2 (45.6) | 20,2 (45.6) | 20,1 (45.4) | 20,0 (45.1) | 19,8 (44.7) | 19,9 (44.9) | 19,7 (44.5) | 19,6 (44.3) | 19,5 (44.0) | 19,5 (44.0) | 19,4 (43.8) | 19,2 (43.4) | 17,9 (40.1) |
| 16,0 (55) | | 17,0 (36.1) | 17,0 (35.9) | 17,0 (35.4) | 17,0 (35.4) | 17,0 (35.0) | 16,9 (34.8) | 16,8 (34.8) | 16,8 (34.6) | 16,6 (34.3) | 16,5 (33.9) | 16,5 (33.9) | 16,4 (33.7) | 16,2 (33.2) | 16,1 (33.0) | 16,1 (33.0) | 16,0 (32.8) | 15,9 (32.6) | 15,7 (32.1) |
| 22,0 (75) | | | | | 11,5 (23.5) | 11,0 (23.1) | 11,0 (22.9) | 10,9 (22.7) | 10,8 (22.4) | 10,6 (22.2) | 10,5 (21.8) | 10,5 (21.8) | 10,4 (21.6) | 10,2 (21.1) | 10,0 (20.9) | 10,1 (20.9) | 10,0 (20.7) | 9,8 (20.2) | 9,6 (20.0) |
| 28,0 (95) | | | | | | | 7,9 (16.5) | 7,8 (16.3) | 7,7 (16.0) | 7,5 (15.6) | 7,4 (15.4) | 7,4 (15.4) | 7,2 (14.9) | 7,0 (14.7) | 6,9 (14.3) | 6,9 (14.3) | 6,8 (14.1) | 6,7 (13.8) | 6,5 (13.4) |
| 32,0 (105) | | | | | | | | 6,4 (14.1) | 6,3 (13.8) | 6,1 (13.4) | 6,0 (13.2) | 6,0 (13.2) | 5,8 (12.7) | 5,6 (12.3) | 5,5 (12.1) | 5,5 (12.1) | 5,4 (11.9) | 5,2 (11.4) | 5,1 (11.2) |
| 34,0 (115) | | | | | | | | | 5,8 (12.1) | 5,5 (11.6) | 5,4 (11.2) | 5,4 (11.2) | 5,2 (11.0) | 5,0 (10.5) | 4,9 (10.1) | 5,0 (10.3) | 4,8 (9.9) | 4,6 (9.7) | 4,5 (9.2) |
| 38,0 (125) | | | | | | | | | | 4,7 (10.3) | 4,5 (9.9) | 4,4 (9.7) | 4,3 (9.4) | 4,1 (9.0) | 4,0 (8.8) | 4,0 (8.8) | 3,8 (8.3) | 3,6 (7.9) | 3,4 (7.4) |
| 40,0 (135) | | | | | | | | | | | | 4,1 (8.5) | 3,9 (8.1) | 3,7 (7.7) | 3,5 (7.2) | 3,5 (7.2) | 3,4 (6.8) | 3,2 (6.6) | 3,0 (6.1) |
| 44,0 (145) | | | | | | | | | | | | | 3,2 (7.0) | 3,0 (6.6) | 2,8 (6.1) | 2,8 (6.1) | 2,6 (5.7) | 2,4 (5.2) | 2,2 (4.8) |
| 46,0 (155) | | | | | | | | | | | | | | 2,7 (5.7) | 2,5 (5.2) | 2,5 (5.0) | 2,3 (4.6) | 2,1 (4.4) | 1,9 (3.9) |
| 50,0 (165) | | | | | | | | | | | | | | | 2,0 (4.4) | 1,9 (4.1) | 1,7 (3.7) | 1,6 (3.5) | |
| 53,3 (175) | | | | | | | | | | | | | | | | 1,6 (3.5) | | | |

For complete chart, refer to www.cranelibrary.com.

Meets ANSI B30.5 Requirements - Capacities do not exceed 75% of static tipping load.
 NOTICE: This capacity chart is for reference only and must not be used for lifting purposes.



Fixed jib range diagram

No. 12000 fixed jib on main boom

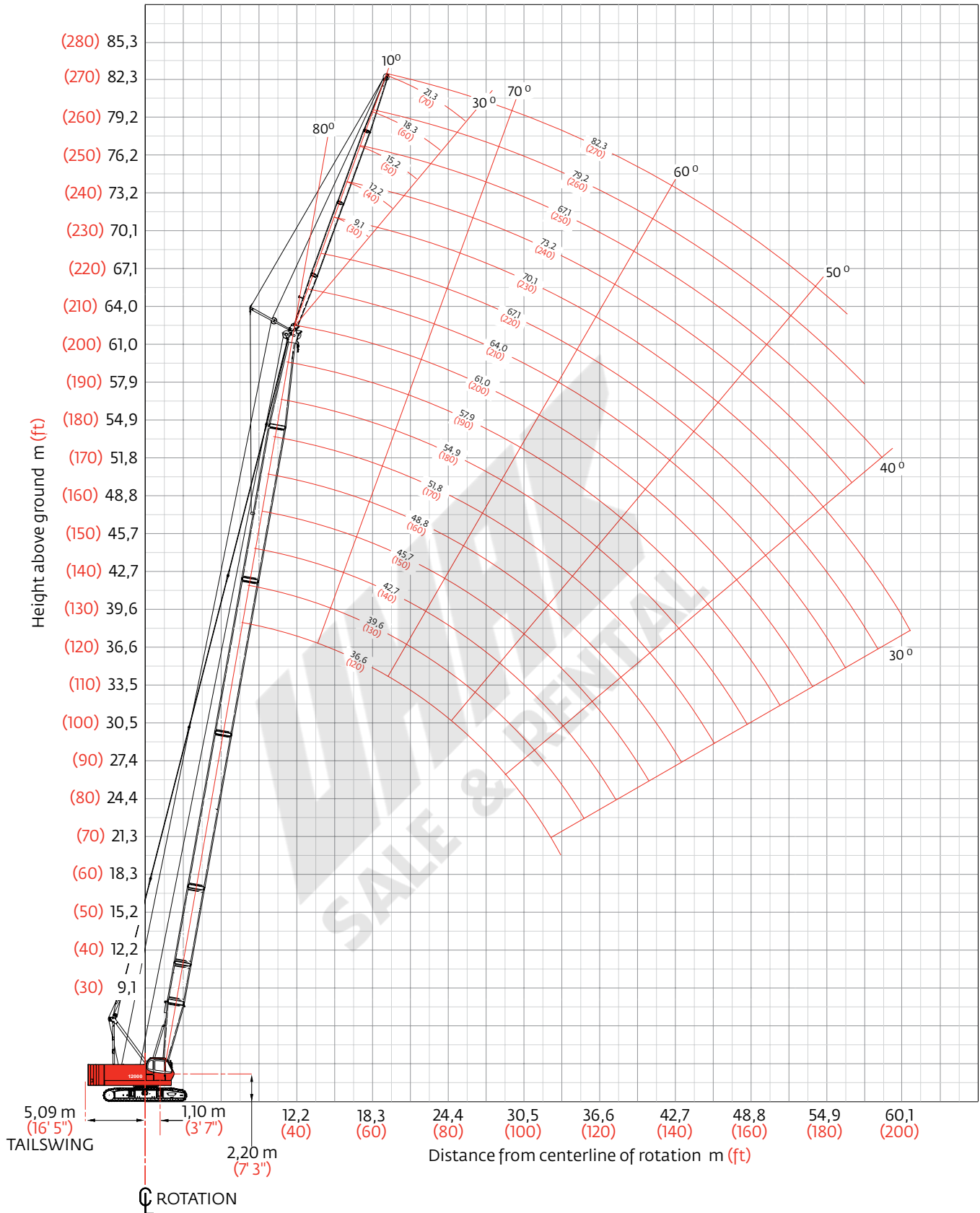



Fixed jib load charts

Model 12000 liftcrane fixed jib capacities - No. 12000 fixed jib on main boom

34 000 kg (75,000 lb) upper counterweight

360° Rating

kg (lb) x 1 000

10° offset

30° offset

| Boom m (ft) | 27,4 (90) | 36,6 (120) | 48,8 (160) | 54,9 (180) | 61,0 (200) |
|----------------|----------------|----------------|----------------|----------------|----------------|
| Radius | | | | | |
| 10,0 (30) | 10,8 (24.0) | | | | |
| 12,0 (40) | 10,8 (24.0) | 10,8 (24.0) | | | |
| 14,0 (50) | 10,8 (24.0) | 10,8 (24.0) | 10,8 (24.0) | — (24.0) | — (24.0) |
| 18,0 (60) | 10,8 (24.0) | 10,8 (24.0) | 10,8 (24.0) | 10,8 (24.0) | 10,8 (24.0) |
| 24,0 (80) | 10,1 (21.9) | 9,7 (21.1) | 9,3 (20.1) | 9,0 (19.8) | 8,8 (19.0) |
| 30,0 (100) | 7,4 (16.1) | 7,1 (15.3) | 6,6 (14.2) | 6,3 (13.6) | 6,1 (13.1) |
| 36,0 (120) | | 5,3 (11.6) | 4,8 (10.4) | 4,5 (9.8) | 4,3 (9.3) |
| 42,0 (140) | | | 3,6 (7.8) | 3,3 (7.1) | 3,0 (6.5) |
| 48,0 (160) | | | 2,7 (5.8) | 2,3 (4.9) | 2,0 (4.2) |
| 52,0 (175) | | | 2,2 (—) | 1,7 (3.6) | 1,5 (—) |
| 56,0 (185) | | | | | |

| Boom m (ft) | 27,4 (90) | 36,6 (120) | 48,8 (160) | 54,9 (180) | 61,0 (200) |
|----------------|---------------|---------------|---------------|---------------|---------------|
| Radius | | | | | |
| 10,0 (30) | | | | | |
| 12,0 (40) | — (21.0) | | | | |
| 14,0 (50) | 9,5 (21.0) | 9,5 (21.0) | | | |
| 18,0 (60) | 9,5 (21.0) | 9,5 (21.0) | 9,5 (21.0) | 9,5 (21.0) | — (21.0) |
| 24,0 (80) | 8,6 (18.9) | 9,4 (20.8) | 9,4 (20.8) | 9,2 (20.2) | 9,1 (19.9) |
| 30,0 (100) | | 7,2 (15.6) | 6,8 (14.7) | 6,5 (14.1) | 6,4 (13.7) |
| 36,0 (120) | | | 5,0 (10.7) | 4,7 (10.2) | 4,5 (9.7) |
| 42,0 (140) | | | | 3,4 (7.4) | 3,2 (7.0) |
| 48,0 (160) | | | | | 2,3 (—) |
| 52,0 (175) | | | | | |
| 56,0 (185) | | | | | |

| Boom m (ft) | 27,4 (90) | 36,6 (120) | 48,8 (160) | 54,9 (180) | 61,0 (200) |
|----------------|---------------|---------------|---------------|---------------|---------------|
| Radius | | | | | |
| 10,0 (30) | 9,0 (—) | | | | |
| 12,0 (40) | 9,0 (20.0) | 9,0 (—) | | | |
| 14,0 (50) | 9,0 (20.0) | 9,0 (20.0) | 9,0 (20.0) | | |
| 18,0 (60) | 9,0 (20.0) | 9,0 (20.0) | 9,0 (20.0) | 9,0 (20.0) | 9,0 (20.0) |
| 24,0 (80) | 7,7 (16.8) | 8,9 (19.5) | 9,0 (20.0) | 9,0 (20.0) | 8,9 (19.7) |
| 30,0 (100) | 6,2 (13.6) | 7,2 (15.7) | 6,8 (14.7) | 6,5 (14.1) | 6,3 (13.6) |
| 36,0 (120) | 5,2 (11.5) | 5,5 (11.9) | 5,0 (10.8) | 4,7 (10.2) | 4,5 (9.8) |
| 42,0 (140) | | 4,3 (9.3) | 3,8 (8.2) | 3,5 (7.5) | 3,3 (7.1) |
| 48,0 (160) | | | 2,9 (6.2) | 2,5 (5.4) | 2,2 (4.7) |
| 52,0 (175) | | | 2,3 (4.9) | 1,9 (4.0) | 1,6 (3.3) |
| 58,0 (185) | | | 1,8 (4.1) | | |

| Boom m (ft) | 27,4 (90) | 36,6 (120) | 48,8 (160) | 54,9 (180) | 61,0 (200) |
|----------------|---------------|---------------|---------------|---------------|---------------|
| Radius | | | | | |
| 10,0 (30) | | | | | |
| 12,0 (40) | | | | | |
| 14,0 (50) | | | | | |
| 18,0 (60) | 5,1 (11.4) | 5,1 (11.4) | 5,1 (—) | | |
| 24,0 (80) | 5,1 (11.2) | 5,1 (11.2) | 5,1 (11.4) | 5,1 (11.4) | 5,1 (11.4) |
| 30,0 (100) | 4,4 (9.8) | 4,8 (10.6) | 5,1 (11.4) | 5,1 (11.4) | 5,1 (11.4) |
| 36,0 (120) | | 4,3 (9.6) | 4,7 (10.4) | 4,9 (10.8) | 4,9 (10.6) |
| 42,0 (140) | | | 4,0 (8.6) | 3,7 (8.1) | 3,6 (7.7) |
| 48,0 (160) | | | | 2,7 (5.9) | 2,5 (5.3) |
| 52,0 (175) | | | | | 1,9 (3.8) |
| 58,0 (185) | | | | | |

For complete chart, refer to www.cranelibrary.com.



Fixed jib load charts

Model 12000 liftcrane fixed jib capacities - No. 12000 fixed jib on main boom

34 000 kg (75,000 lb) upper counterweight

360° Rating

kg (lb) x 1 000

| | | 10° offset | | | | | 30° offset | | | | | |
|--------------------|---------------|---------------|---------------|---------------|---------------|---------------|----------------|--------------|---------------|---------------|---------------|---------------|
| Boom m (ft) | | 27,4 (90) | 36,6 (120) | 48,8 (160) | 54,9 (180) | 61,0 (200) | Boom m (ft) | 27,4 (90) | 36,6 (120) | 48,8 (160) | 54,9 (180) | 61,0 (200) |
| jib 21,3 m (70 ft) | Radius | | | | | | | | | | | |
| | 12,0 (45) | 7,1 (15.7) | | | | | 12,0 (45) | | | | | |
| | 18,0 (60) | 6,7 (14.8) | 6,8 (15.1) | 6,9 (15.4) | 7,0 (15.6) | 7,1 (15.7) | 18,0 (60) | 3,6 (—) | | | | |
| | 22,0 (75) | 6,4 (13.9) | 6,6 (14.4) | 6,7 (14.8) | 6,8 (15.0) | 6,9 (15.1) | 22,0 (75) | 3,6 (8.1) | 3,6 (8.1) | | | |
| | 26,0 (90) | 5,5 (11.5) | 6,3 (13.3) | 6,5 (14.3) | 6,6 (14.4) | 6,7 (14.6) | 26,0 (90) | 3,5 (7.6) | 3,6 (8.1) | 3,6 (8.1) | 3,6 (8.1) | 3,6 (8.1) |
| | 32,0 (110) | 4,4 (9.4) | 5,1 (10.9) | 6,0 (12.7) | 6,0 (12.3) | 5,8 (11.9) | 32,0 (110) | 3,0 (6.5) | 3,3 (7.0) | 3,5 (7.6) | 3,6 (7.8) | 3,6 (8.0) |
| | 38,0 (130) | 3,7 (7.9) | 4,3 (9.2) | 4,7 (9.7) | 4,4 (9.1) | 4,2 (8.6) | 38,0 (130) | 2,7 (—) | 2,9 (6.3) | 3,1 (6.9) | 3,2 (7.1) | 3,3 (7.3) |
| | 44,0 (145) | 3,2 (7.1) | 3,7 (8.2) | 3,6 (7.9) | 3,3 (7.2) | 3,1 (6.8) | 44,0 (145) | | 2,6 (5.9) | 2,9 (6.4) | 3,0 (6.6) | 3,0 (6.8) |
| | 50,0 (170) | | 3,2 (6.8) | 2,7 (5.6) | 2,4 (4.7) | 2,0 (4.1) | 50,0 (170) | | | 2,6 (5.9) | 2,7 (5.5) | 2,5 (4.9) |
| | 54,0 (180) | | | 2,2 (4.8) | 1,8 (3.9) | | 54,0 (180) | | | | 2,1 (4.5) | 1,8 (3.9) |
| | 56,0 (190) | | | 2,0 (4.0) | 1,6 (—) | | 56,0 (190) | | | | | 1,6 (—) |
| | 60,0 (200) | | | 1,6 (3.3) | | | 60,0 (200) | | | | | |

For complete chart, refer to www.cranelibrary.com.

Meets ANSI B30.5 Requirements - Capacities do not exceed 75% of static tipping load.
 NOTICE: This capacity chart is for reference only and must not be used for lifting purposes.



Luffing jib range diagram

No. 12000 luffing jib on luffing boom

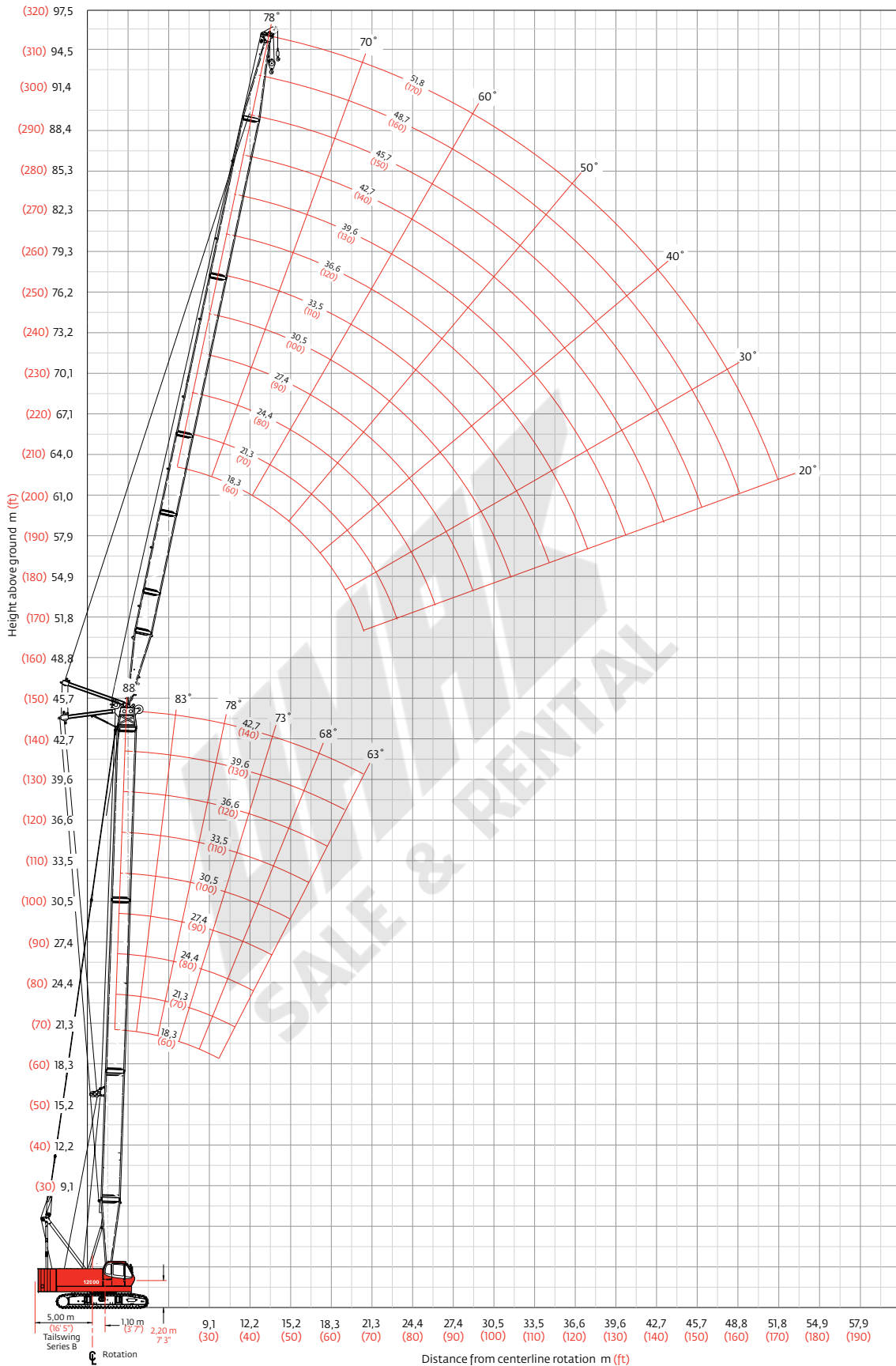



Luffing jib load charts

Model 12000 liftcrane luffing jib capacities - No. 12000 luffing jib on luffing boom

34 000 kg (75,000 lb) counterweight

360° Rating

kg (lb) x1000

88° boom angle

| | Boom | 18,2 | 24,4 | 30,5 | 36,6 | 45,7 | | Boom | 18,2 | 24,4 | 30,5 | 36,6 | 45,7 |
|------------------------------------|------------|-------------|-------------|-------------|-------------|-------------|------------|------------|-------------|-------------|-------------|-------------|-------------|
| | m (ft) | (60) | (80) | (100) | (120) | (150) | | m (ft) | (60) | (80) | (100) | (120) | (150) |
| Luffing jib length 18,3 m (60 ft) | Radius | | | | | | | Radius | | | | | |
| | 7,9 (26) | 36,2 (80.0) | — (80.0) | | | | | 7,9 (26) | | | | | |
| | 9,0 (30) | 31,9 (69.3) | 31,9 (69.3) | 31,9 (69.3) | 31,9 (69.3) | 19,5 (42.5) | | 9,0 (30) | | | | | |
| | 10,0 (36) | 28,8 (57.7) | 28,7 (57.7) | 28,7 (57.7) | 28,7 (57.7) | 17,9 (36.4) | | 10,0 (36) | — (57.7) | | | | |
| | 14,0 (45) | 20,4 (46.2) | 20,5 (46.2) | 20,5 (46.2) | 20,5 (46.2) | 12,9 (29.1) | | 14,0 (45) | 20,5 (46.2) | 20,5 (46.2) | 20,5 (46.2) | 20,5 (46.2) | 12,6 (28.4) |
| | 18,0 (65) | 14,1 (—) | 14,4 (26.9) | 14,6 (27.3) | 14,8 (27.6) | 9,5 (18.3) | | 18,0 (65) | 14,7 (28.0) | 15,0 (28.4) | 15,2 (28.9) | 15,4 (29.1) | 9,6 (19.0) |
| | 20,0 (80) | 11,2 (—) | 11,3 (—) | 11,5 (—) | 11,8 (—) | 7,9 (—) | | 24,0 (80) | 9,4 (20.3) | 9,4 (20.3) | 9,5 (20.5) | 9,6 (20.7) | 6,6 (14.3) |
| | 24,0 (80) | | | | | | | 30,0 (100) | 6,4 (13.7) | 6,4 (13.7) | 6,4 (13.7) | 6,4 (13.7) | 4,5 (9.7) |
| | 30,0 (100) | | | | | | | 32,0 (120) | | | 5,4 (—) | 5,5 (—) | 3,9 (—) |
| | 36,0 (120) | | | | | | | 36,0 (120) | | | | | |
| 44,0 (145) | | | | | | | 44,0 (145) | | | | | | |
| Luffing jib length 39,6 m (130 ft) | Radius | | | | | | | Radius | | | | | |
| | 14,0 (45) | 20,7 (46.2) | 20,7 (46.2) | 20,7 (46.2) | | | | 14,0 (45) | | | | | |
| | 16,0 (55) | 17,7 (36.8) | 17,9 (37.5) | 17,9 (37.5) | 17,1 (36.4) | | | 16,0 (55) | — (30.0) | — (30.2) | | | |
| | 22,0 (75) | 10,9 (22.7) | 11,0 (22.9) | 11,2 (23.1) | 11,3 (23.4) | | | 22,0 (75) | 10,3 (21.6) | 10,4 (21.8) | 10,4 (22.0) | 10,6 (22.3) | |
| | 28,0 (95) | 7,3 (15.2) | 7,4 (15.4) | 7,4 (15.4) | 7,5 (15.7) | | | 28,0 (95) | 6,8 (14.1) | 6,9 (14.3) | 6,9 (14.3) | 7,0 (14.6) | |
| | 34,0 (115) | 5,0 (10.6) | 5,1 (10.6) | 5,1 (10.6) | 5,1 (10.8) | | | 34,0 (115) | 4,6 (9.7) | 4,6 (9.7) | 4,7 (9.7) | 4,7 (9.7) | |
| | 40,0 (130) | 3,4 (8.2) | 3,4 (8.2) | 3,4 (8.2) | 3,4 (8.2) | | | 40,0 (130) | 3,2 (7.3) | 3,2 (7.3) | 3,2 (7.3) | 2,6 (6.2) | |
| | 44,0 (150) | | | | | | | 44,0 (150) | 2,6 (4.9) | 2,6 (4.0) | 1,6 (—) | | |
| | 50,0 (165) | | | | | | | 50,0 (165) | — (2.2) | | | | |
| | 52,0 (175) | | | | | | | 52,0 (175) | | | | | |
| 56,0 (190) | | | | | | | 56,0 (190) | | | | | | |
| Luffing jib length 51,8 m (170 ft) | Radius | | | | | | | Radius | | | | | |
| | 14,0 (45) | | | | | | | 14,0 (45) | | | | | |
| | 16,0 (55) | | | | | | | 16,0 (55) | | | | | |
| | 22,0 (75) | | | | | | | 22,0 (75) | | | | | |
| | 28,0 (95) | | | | | | | 28,0 (95) | | | | | |
| | 34,0 (115) | | | | | | | 34,0 (115) | | | | | |
| | 40,0 (130) | | | | | | | 40,0 (130) | | | | | |
| | 44,0 (150) | | | | | | | 44,0 (150) | | | | | |
| | 50,0 (165) | | | | | | | 50,0 (165) | | | | | |
| | 52,0 (175) | | | | | | | 52,0 (175) | | | | | |
| 56,0 (190) | | | | | | | 56,0 (190) | | | | | | |

For complete chart, refer to www.cranelibrary.com.

Meets ANSI B30.5 Requirements - Capacities do not exceed 75% of static tipping load.
 NOTICE: This capacity chart is for reference only and must not be used for lifting purposes.



Luffing jib load charts

Model 12000 liftcrane luffing jib capacities - No. 12000 luffing jib on luffing boom

34 000 kg (75,000 lb) counterweight

360° Rating

kg (lb) x1 000

73° boom angle

| | Boom | 18,2 | 24,4 | 30,5 | 36,6 | 45,7 | | Boom | 18,2 | 24,4 | 30,5 | 36,6 | 45,7 |
|------------------------------------|------------|-------------|-------------|-------------|------------|------------|--|------------|------------|------------|------------|------------|-----------|
| | m (ft) | (60) | (80) | (100) | (120) | (150) | | m (ft) | (60) | (80) | (100) | (120) | (150) |
| Luffing jib length 18,3 m (60 ft) | Radius | | | | | | | Radius | | | | | |
| | 16,0 (55) | — (35.9) | | | | | | 16,0 (55) | | | | | |
| | 20,0 (65) | 13,0 (29.1) | 12,4 (27.6) | | | | | 20,0 (65) | | | | | |
| | 22,0 (75) | 11,5 (24.0) | 11,0 (23.1) | 10,4 (22.3) | — (20.3) | | | 22,0 (75) | | | | | |
| | 26,0 (85) | | 8,5 (19.6) | 8,4 (18.7) | 8,0 (17.9) | 6,9 (15.4) | | 26,0 (85) | 8,8 (19.6) | 8,1 (17.9) | | | |
| | 28,0 (95) | | | 7,4 (—) | 7,2 (15.2) | 6,6 (13.9) | | 28,0 (95) | 7,9 (16.8) | 7,5 (15.9) | 6,9 (15.0) | — (13.0) | |
| | 32,0 (105) | | | | | 5,3 (11.9) | | 32,0 (105) | 6,6 (14.6) | 6,2 (13.7) | 5,8 (13.0) | 5,4 (12.1) | 4,2 (9.3) |
| | 34,0 (115) | | | | | | | 34,0 (115) | 5,9 (12.8) | 5,6 (11.9) | 5,3 (11.2) | 4,9 (10.4) | 4,1 (9.0) |
| | 38,0 (125) | | | | | | | 38,0 (125) | | 4,7 (—) | 4,5 (9.9) | 4,1 (9.0) | 3,5 (7.7) |
| | 40,0 (135) | | | | | | | 40,0 (135) | | | | 3,8 (7.9) | 3,1 (6.6) |
| | 42,0 (140) | | | | | | | 42,0 (140) | | | | | 2,8 (6.2) |
| Luffing jib length 39,6 m (130 ft) | Radius | | | | | | | Radius | | | | | |
| | 28,0 (95) | — (15.2) | | | | | | 28,0 (95) | | | | | |
| | 32,0 (105) | 6,3 (13.9) | 5,8 (13.0) | — (11.2) | | | | 32,0 (105) | | | | | |
| | 34,0 (115) | 5,7 (12.1) | 5,3 (11.2) | 5,0 (10.6) | 4,2 (9.3) | | | 34,0 (115) | — (10.1) | | | | |
| | 38,0 (125) | 4,8 (10.6) | 4,5 (9.9) | 4,2 (9.3) | 3,7 (8.2) | | | 38,0 (125) | 4,3 (9.5) | 3,8 (8.4) | — (6.6) | | |
| | 40,0 (135) | 4,4 (9.3) | 4,1 (8.6) | 3,8 (7.9) | 3,4 (7.1) | | | 40,0 (135) | 3,9 (8.4) | 3,6 (7.5) | 2,9 (6.6) | 2,2 (4.9) | |
| | 44,0 (145) | 3,7 (8.2) | 3,5 (7.7) | 3,1 (6.8) | 2,8 (6.2) | | | 44,0 (145) | 3,2 (7.1) | 2,9 (6.4) | 2,5 (5.5) | 2,1 (4.6) | |
| | 46,0 (155) | | 3,2 (—) | 2,8 (6.0) | 2,5 (5.3) | | | 46,0 (155) | 2,9 (6.2) | 2,6 (5.5) | 2,2 (4.6) | 1,8 (4.0) | |
| | 48,0 (160) | | | 2,6 (—) | 2,3 (4.9) | | | 48,0 (160) | 2,7 (5.7) | 2,4 (5.1) | 1,9 (4.2) | 1,7 (3.5) | |
| | 52,0 (175) | | | | | | | 52,0 (175) | 2,2 (4.6) | 1,8 (4.0) | 1,5 (3.3) | | |
| | 56,0 (185) | | | | | | | 56,0 (185) | 1,7 (—) | 1,5 (3.3) | | | |

For complete chart, refer to www.cranelibrary.com.

Meets ANSI B30.5 Requirements - Capacities do not exceed 75% of static tipping load.
NOTICE: This capacity chart is for reference only and must not be used for lifting purposes.



Luffing jib load charts

Model 12000 liftcrane luffing jib capacities - No. 12000 luffing jib on luffing boom

34 000 kg (75,000 lb) counterweight

360° Rating

kg (lb) x1000

63° boom angle

| | Luffing jib length 18,3 m (60 ft) | | | | | | Luffing jib length 30,5 m (100 ft) | | | | |
|---------------|-----------------------------------|---------------|---------------|---------------|---------------|--|------------------------------------|----------------|---------------|--------------|---------------|
| | Boom m (ft) | 18,2 (60) | 24,4 (80) | 30,5 (100) | 36,6 (120) | | 45,7 (150) | Boom m (ft) | 18,2 (60) | 24,4 (80) | 30,5 (100) |
| Radius | | | | | | | | | | | |
| 22,0 (75) | — (22.5) | | | | | | 22,0 (75) | | | | |
| 24,0 (80) | 9,7 (21.2) | | | | | | 24,0 (80) | | | | |
| 26,0 (85) | 8,6 (19.4) | 7,9 (17.6) | | | | | 26,0 (85) | | | | |
| 28,0 (95) | | 7,4 (15.7) | — (13.7) | | | | 28,0 (95) | | | | |
| 32,0 (105) | | | 5,5 (12.3) | 4,7 (10.4) | | | 32,0 (105) | 6,0 (13.4) | | | |
| 34,0 (115) | | | | 4,6 (9.7) | — (6.4) | | 34,0 (115) | 5,5 (11.7) | 4,8 (10.6) | | |
| 38,0 (125) | | | | | 2,9 (6.4) | | 38,0 (125) | 4,7 (10.4) | 4,2 (9.3) | 3,5 (7.9) | |
| 40,0 (135) | | | | | | | 40,0 (135) | | 3,9 (8.2) | 3,3 (7.1) | 2,4 (5.3) |
| 44,0 (145) | | | | | | | 44,0 (145) | | | 2,8 (6.2) | 2,2 (4.9) |
| 46,0 (150) | | | | | | | 46,0 (150) | | | | 2,0 (4.4) |

| | Luffing jib length 39,6 m (130 ft) | | | | Luffing jib length 51,8 m (170 ft) | |
|---------------|------------------------------------|--------------|--------------|--|------------------------------------|----------------|
| | Boom m (ft) | 18,2 (60) | 24,4 (80) | | 30,5 (100) | Boom m (ft) |
| Radius | | | | | | |
| 36,0 (120) | — (9.7) | | | | | 36,0 (120) |
| 38,0 (125) | 4,4 (9.7) | | | | | 38,0 (125) |
| 40,0 (130) | 4,0 (9.0) | 3,2 (7.1) | | | | 40,0 (130) |
| 42,0 (140) | 3,6 (7.9) | 3,1 (6.8) | — (4.6) | | | 42,0 (140) |
| 44,0 (150) | 3,4 (7.1) | 2,9 (6.0) | 2,0 (4.6) | | | 44,0 (150) |
| 48,0 (160) | 2,9 (—) | 2,4 (5.1) | 1,9 (4.0) | | | 48,0 (160) |
| 50,0 (170) | | 2,1 (—) | 1,7 (3.3) | | | 50,0 (170) |
| 52,0 (175) | | | 1,5 (3.1) | | | 52,0 (175) |
| 54,0 (180) | | | | | | 54,0 (180) |
| 58,0 (190) | | | | | | 58,0 (190) |

For complete chart, refer to www.cranelibrary.com.

Meets ANSI B30.5 Requirements - Capacities do not exceed 75% of static tipping load.
 NOTICE: This capacity chart is for reference only and must not be used for lifting purposes.



Clamshell

Boom:

Welded lattice construction using tubular, high-tensile steel chords with pin connections between sections.

Basic boom length: 15,2 m (50 ft)

Max. boom length: 30,5 m (100 ft)

Limit of empty clamshell bucket weight: 2 100 kg (4,600 lb)

Boom component chart

| Boom length m (ft) | Boom arrangement |
|--------------------|--|
| 15,2 (50) | Base-Tip |
| 18,3 (60) | Base-A-Tip |
| 21,3 (70) | Base-A-A-Tip, Base-B-Tip |
| 24,4 (80) | Base-A-B-Tip |
| 27,4 (90) | Base-A-A-B-Tip, Base-B-B-Tip, Base-C-Tip |
| 30,5 (100) | Base-A-B-B-Tip, Base-A-C-Tip |

Base = 7,6 m (25 ft)

Insert: A = 3,05 m (10 ft)

B = 6,10 m (20 ft)

C = 12,2 m (40 ft)

Tip = 7,2 m (25 ft)

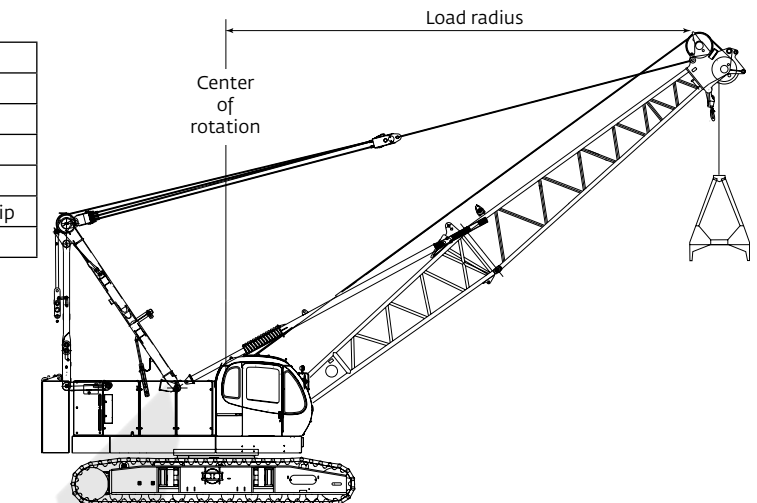

1. Figures represent maximum allowable capacity, and assume level ground and ideal working conditions.
2. Capacities are calculated at 66% of the minimum tipping loads.
3. Capacities are maximum recommended by PCSA Standard #4. Allowances must be made by the user for such unfavorable conditions as a soft or uneven supporting surface, rapid cycle operations, or bucket suction.
4. The combined weight of the bucket and load must not exceed these capacities.
5. Boom length for clamshell operation should not exceed 30,5 m (100 ft).

Clamshell Capacities

10 000 kg (22,050 lb) counterweight
(one upper counterweight, crawlers extended)

kg (lb) x 1 000

| Boom m (ft) | 15,2 (50) | 18,3 (60) | 21,3 (70) | 24,4 (80) | 27,4 (90) | 30,5 (100) |
|-------------|-------------|-------------|------------|------------|------------|------------|
| Radius | | | | | | |
| 7,0 (22) | 10,0 (25.0) | | | | | |
| 8,0 (26) | 10,0 (25.0) | | | | | |
| 9,0 (30) | 10,0 (25.0) | 10,0 (25.0) | | | | |
| 10,0 (34) | 10,0 (25.0) | 9,7 (25.0) | 9,7 (25.0) | | | |
| 14,0 (45) | 10,0 (23.1) | 7,8 (22.9) | 7,8 (22.7) | 7,8 (22.5) | 7,8 (21.6) | |
| 15,0 (50) | | 6,6 (19.8) | 6,6 (19.6) | 6,6 (19.4) | 6,6 (19.2) | 6,6 (18.5) |
| 17,0 (55) | | 5,7 (12.5) | 5,7 (17.2) | 5,7 (17.0) | 5,7 (16.8) | 5,7 (16.5) |
| 18,0 (60) | | | 5,0 (15.2) | 5,0 (15.0) | 5,0 (14.8) | 5,0 (14.6) |
| 21,0 (70) | | | | 4,4 (11.9) | 4,3 (11.7) | 4,2 (11.5) |
| 24,0 (80) | | | | | — (9.5) | — (9.3) |
| 25,0 (85) | | | | | | — (8.4) |
| 27,0 (90) | | | | | | — (7.7) |



Manitowoc Crane Care

Crane Care is Manitowoc's comprehensive service and support program. It includes classroom and on-site training, prompt parts availability, expert field service, technical support and documentation.

That's commitment you won't find anywhere else.

That's Crane Care.

Service training

Manitowoc specialists work with you in our training centers and in the field to make sure you know how to get maximum performance, reliability and life from your cranes.

Manitowoc Cranes Technical Training Centers provide valuable multi-level training, which is available for all models and attachments, in the following format:

- **Intro to Canbus and Canbus 1, 2, 3**
- **Intro to EPIC and EPIC 1, 2, 3**
- **Small Crawler 1**
- **Canbus 1 and 2 assembly, operation and maintenance**
- **EPIC 1 and 2 assembly, operation and maintenance**

Refer to www.manitowoc.com for course descriptions.

Parts availability

Genuine Manitowoc replacement parts are accessible through your distributor 24 hours a day, 7 days a week, 365 days a year.

Service interval kits

200 hour kit

1,000 hour kit

2,000 hour kit

Hydraulic test kit

U.S. standard tools kit

Field service

Factory-trained service experts are always ready to help maintain your crane's peak performance.

For a worldwide listing of dealer locations, please consult our website at: www.manitowoc.com

Technical support

Manitowoc's dealer network and factory personnel are available 24 hours a day, 7 days a week, 365 days a year to answer your technical questions and more, with the help of computerized programs that simplify crane selection, lift planning, and ground-bearing calculations.

For a worldwide listing of dealer locations, please consult our website at: www.manitowoc.com

Technical documentation

Manitowoc has the industry's most extensive documentation; available in major languages and formats that include print, videotape, and DVD/CD.

Additional copies available through your Authorized Manitowoc Distributor.

- Crane operator's manual
- Crane parts manual
- Crane capacity manual
- Crane vendor manual
- Crane service manual
- Luffing jib operator's/parts manual
- Capacity chart manual - attachments

CD rom versions of the operator's and parts manuals are shipped with each crane. Also available are the following CDs:

- Crane Care Owner CD –
- Ground Bearing Pressure Estimator CD
- Crane Selection and Planning Software (CompuCRANE®)
- EPIC® Crane Library CD consisting of capacity charts, range diagrams, wire rope specifications, travel specifications, crane weights, counterweight arrangements, luffing jib raising procedures, operating range diagrams, drum and lagging charts, boom rigging drawings, jib rigging drawings, outline dimensions and wind condition charts.

Available from your Authorized Manitowoc Cranes Distributor, these videos are available in NTSC, PAL, SECAM, and DVD formats.

- Your Capacity Chart Video
- Respect the Limits Video
- Crane Safety Video
- Boom Inspection/Repair Video

Crane Care Package

Manitowoc has assembled all of the available literature, CD's and videos listed above plus several Manitowoc premiums into one complete Crane Care Package.



Notes

UMAX
SALE & RENTAL



Manitowoc Cranes

Regional headquarters

Americas**Manitowoc, Wisconsin, USA**

Tel: +1 920 684 6621

Fax: +1 920 683 6277

Shady Grove, Pennsylvania, USA

Tel: +1 717 597 8121

Fax: +1 717 597 4062

Europe, Middle East, Africa**Ecully, France**

Tel: +33 (0)4 72 18 20 20

Fax: +33 (0)4 72 18 20 00

China**Shanghai, China**

Tel: +86 21 6457 0066

Fax: +86 21 6457 4955

Greater Asia-Pacific**Singapore**

Tel: +65 6264 1188

Fax: +65 6862 4040

Regional offices

Americas**Brazil**

Alphaville

Mexico

Monterrey

Chile

Santiago

Europe, Middle East, Africa**Czech Republic**

Netvorice

France

Baudemont

Cergy

Decines

Germany

Langenfeld

Hungary

Budapest

Italy

Lainate

Netherlands

Breda

Poland

Warsaw

Portugal

Baltar

Russia

Moscow

U.A.E.

Dubai

U.K.

Buckingham

China

Beijing

Chengdu

Guangzhou

Xian

Greater Asia-Pacific**Australia**

Adelaide

Brisbane

Melbourne

Sydney

India

Calcutta

Chennai

Delhi

Hyderabad

Pune

Korea

Seoul

Philippines

Makati City

Singapore

Factories

Brazil

Alphaville

China

TaiAn

Zhangjiagang

France

Charlieu

Moulines

Germany

Wilhelmshaven

India

Pune

Italy

Niella Tanaro

Portugal

Baltar

Fânzeres

Slovakia

Saris

USA

Manitowoc

Port Washington

Shady Grove

This document is non-contractual. Constant improvement and engineering progress make it necessary that we reserve the right to make specification, equipment, and price changes without notice. Illustrations shown may include optional equipment and accessories and may not include all standard equipment.

Manitowoc 12000

Product Guide



Features

- 110 t (120 USt) capacity
- 397 mton-m (2,880 ft-kips) maximum load moment
- 70,1 m (230 ft) heavy-lift boom
- 82,3 m (270 ft) fixed jib on heavy-lift boom
- 94,5 m (310 ft) luffing jib on heavy-lift boom
- 247 kW (332 HP) engine

Contents

| | |
|---------------------------------|----|
| Specifications | 3 |
| Outline dimensions | 6 |
| Transport data | 10 |
| Crane assembly | 11 |
| Performance data | 12 |
| Load chart notes | 13 |
| Boom combinations | 14 |
| Main boom range / load charts | 16 |
| Fixed jib range / load charts | 18 |
| Luffing jib range / load charts | 21 |
| Clamshell | 25 |
| Manitowoc Crane Care | 26 |

Specifications

Upperworks



Engine

Hino P11C-UN, 6 cylinder, water-cooled diesel, direct fuel injection with turbocharger, 247 kW (332 HP) at 2000 high-idle RPM. Maximum torque 1300 N•m (959 lb•ft) net at 1,500 rpm (SAE J 1349).

One diesel fuel tank, 400 liters (105 gallons) capacity.

Two 12 volt 136 AH capacity batteries, 24 volt system and 50 amp alternator.

All wiring harnesses and connectors are numbered for easier servicing. Machine is equipped with individual fused branch circuits.



Controls

Full-flow hydraulic control system for constant variable pressure to front and rear drums, boom hoist brakes and clutches. Controls respond instantly to the touch, delivering smooth function operation.

Relief valve pressures:

Load hoist, boom hoist

and propel system 315kg/cm2 (4,480 psi)

Swing system 280 kg/cm2, (3,980psi)

Control system 80 kg/cm2 (1,140 psi)



Hydraulic system

All four variable displacement piston-type pumps are driven by a heavy-duty pump drive. One of these pumps is used in the right propel circuit and hook hoist circuit, and can accommodate an optional third circuit. Another is used in the left propel circuit and hook hoist circuit. The third variable displacement pump is used in the boom hoist circuit. The fourth variable displacement pump is used in the swing circuit. In addition, two gear pumps are used in the control system and auxiliary equipment, and two gear pumps serve the brake cooling system.

Maximum pressure rating . . . 325 kg/cm2 (4,640 psi)

Load hoist, boom hoist and propel . . 2 Piston pumps

Boom Hoist 1 Piston pump

Swing 1 Piston pump

Control system and auxiliary 2 Gear pumps

Brake cooling system 2 Gear pumps

Reservoir capacity: 460 liter (121 US gallon).

Cooling: Oil-to-air heat exchanger (plate-fin type).

Filtration: Full-flow and bypass type with replaceable paper element.



Drums

Front and rear drums for load hoist powered by hydraulic variable displacement piston-type motors, driven through planetary reducers. Powered hoisting/lowering and free-fall operation is standard. Drum turn indicators for front and rear drums are also standard.

Brake & Clutches (compatible): Forced-circulation oil-cooled wet-type multi-disc brakes, each using positive and negative actuation. An external ratchet is fitted for locking the drums.

Drums: (front and rear) 613 mm (24.1") P.C.D. X 622 mm (24.5") wide drums, grooved for 26.0 mm wire rope.

Wire rope capacity:

Front drum 260 m (853 ft) working length

Rear drum 230 m (754 ft) working length

Storage length (each drum) 253 m (830')

Line speed: Single line on the first drum layer

Hoisting: 120m/min (394 ft/min)

Lowering: 120m/min (394 ft/min)

➤ **Optional third drum:** same dimensions and specifications as front and rear drums. Wire rope working length is 240 m (787').



Swing system

Swing unit: Powered by a hydraulic piston-type motor driving spur gears through planetary reducers, the swing system provides 360° rotation.

Swing brake: A spring-set, hydraulically released multiple-disc brake is internally fitted in swing motor.

Swing lock: 2 Position lock for transportation.

Rotating bed turntable: Single-row ball bearing with an integral internally cut swing gear.

Swing speed: 2.7 rpm



Boom support system

Single drum powered by a hydraulic axial piston motor through a planetary reducer.

Brake: A spring-set, hydraulically released multiple-disc brake is internally fitted in the boom hoist motor and

Specifications

operated through a counter-balance valve. An external ratchet is fitted for locking the drum.

Drum: Single drum, grooved for 20 mm dia. wire rope. Boom Hoist reeving is 10-part line.

Wire Rope Capacity:

Drum 155 m (508 ft) working length.

Line speed: Single line on the first drum layer

Hoisting: 48m/min (157 ft/min)

Lowering: 48m/min (157 ft/min)



Gantry

This high folding type gantry is fitted with a sheave frame for boom hoist reeving. It provides full up, full down positions.



Counterweight

| Qty. | Item | Unit weight | | Total weight | |
|----------------------------|-----------------|---------------|---------------|--------------|--------|
| | | kg | lb | kg | lb |
| 1 | Counterweight A | 10 000 | 22,050 | 10 000 | 22,050 |
| 2 | Counterweight B | 7 000 | 15,435 | 14 000 | 30,870 |
| 1 | Counterweight C | 10 000 | 22,050 | 10 000 | 22,050 |
| Counterweight Total | | 34 000 | 74,970 | | |



Operator's cab

Totally enclosed, full vision cab fitted with tinted safety glass. A fully adjustable, highbacked seat with arm rests permits operators to set their ideal working position. Side mounted console for auxiliary controls and instruments. An air conditioner, a signal horn, cigarette lighter, windshield wiper and inspection lamp socket are standard features.

Controls

In front of operator are the foot pedals for front, rear and third drum (option) brakes and foot throttle pedal. At operator's right side are the travel (propel) control levers and the function lock lever. To the operator's right front are the boom hoist control lever, front and rear winch control levers and the free-fall select switches for the front and rear winches and drum turn indicators (front/rear drum). To the operators left front are the swing control lever and third drum (option) control lever. To the operator's left are the crawler extend/retract lever and the positive swing lock. The left-hand console contains switches for the anti-two-block/boom overhoist. Directly in front of the console are the drum pawl lock for boom, front, rear and third drum (option) and the engine ignition key. The swing parking brake and signal horn are mounted on the swing control lever.

Gauges

Fuel gauge, engine water temperature gauge, hour meter and tachometer are located on the monitor display.

Warning display

All potential warnings, including battery charge, engine oil pressure, air cleaner, engine oil filter, control main pressure, and hydraulic oil temperature will appear on the monitor display when a fault occurs.

Safety device

Function lock lever, anti-two-block, boom over hoist limit switch, boom angle indicator, signal horn, boom hoist drum lock, front and rear drum lock, swing lock, swing alarm (buzzer and lamps), boom backstops and load moment indicator.

Lowerworks



Carbody

The durable carbody features steel welded construction with extendible axles.



Crawlers

Crawler assemblies can be hydraulically extended for wide-track operation or retracted for transportation. Crawler belt tension adjusted with hydraulic jack and maintained by shims between idler block and frame.

Crawler drive

The independent hydraulic propel drive is built into each crawler side frame. Each drive consists of a hydraulic motor driving a propel sprocket through a planetary gearbox. The hydraulic motor and gearbox are built into the crawler side frame within the shoe width. The track rollers are sealed for maintenance-free operation.

Crawler brakes

Spring set, hydraulically released, multiple disc-type parking brakes are built into each propel drive.

Steering mechanism

The hydraulic propel system provides both skid steering (driving one track only) and counter-rotating steering (driving each track in opposite direction) and differential track speed.

Crawler shoes

66 shoes per side, 914 mm (36") wide each crawler.

Travel speed

(High/Low) 1.4/1.0 km/h (0.87/0.62 mph)

Specifications

Attachments



Boom

Welded lattice construction using tubular, high-tensile steel chords with pin connections between sections. Boom tip is open throat construction. Two idler sheaves and four point sheaves are standard.

Basic boom length 15,24 m (50') consists of the boom butt section 7,62 m (25' 0") and boom top section 7,62 m (25' 0").

Optional boom inserts are available to provide extension capabilities. They also have welded lattice construction with tubular, high-tensile steel chords and pin connections on each one of 3,0 m (10'), 6,1 m (20'), 12,2 m (40') inserts.

Maximum total length of boom 70,1 m (230').



Fixed jib

The optional fixed jib employs welded lattice construction with tubular, high-tensile steel chords with pin connections between sections.

Basic jib length 9,14 m (30') consists of jib butt section 4,57 m (15') and jib top section 4,57 m (15').

Optional jib boom inserts of 3,0 m (10'), 6,1 m (20') are available for extension capabilities up to 21,3 m (70').

Maximum total length of boom and jib 61,0 m (200') + 21,3 m (70') is 82,3 m (270').



Luffing jib

Optional: Components to make up 18,3 m (60') basic luffing boom including 7,62 m (25') butt, 9,14 m (30') special luffing boom insert (with idler sheave), 1,5 m (5') top, boom strut assembly, jib strut assembly, jib stop assembly, strut backstops, backstay pendants with sheaves, mounting parts and LMI hardware.

Optional: 3,1 m (10'), 6,1 m (20'), and 12,2 m (40') luffing boom inserts. Utilize optional boom inserts to make up to 45,7 m (150') of luffing boom.

Optional: 18,3 m (60') basic luffing jib assembly including 5,8 m (19') luffing jib butt, 6,1 m (20') luffing jib insert, 6,4 m (21') luffing jib top, 6,4 m (21') front strut assembly, 5,3 m (17' 5") rear strut assembly, and luffing jib point roller assembly (single sheave) which is required during erection of the jib.

Maximum 51,8 m (170') jib length for 42,7 m (140') boom length and maximum 30,4 m (100') jib length for 45,7 m (150') boom length.

Note: Luffing boom utilizes the liftcrane boom inserts (except for the 30' special luffing boom insert). Also, the third drum and wire rope must be ordered with luffing jib attachment.

Tools and accessories

A set of tools and accessories are furnished.

Optional equipment

- Optional: Blocks and Hooks each with roller bearing sheaves grooved for 26.0 mm diameter wire rope, and roller bearing swivel with hook latch.
- 12 t ball hook, 456 kg wedge socket for 26 mm wire rope. (15 USt ball hook, 1,310 lb wedge socket for 26 mm wire rope.)
- 35 t hook block, 700 kg with one 622 mm Nominal O.D. roller bearing sheave. (40 USt hook block, 1,881 lb with one 24" Nominal O.D. roller bearing sheaves.)
- 70 t hook block, 900 kg, three 622 mm Nominal O.D. roller bearing sheave. (90 USt hook block, 4,060 lb, with three 24" Nominal O.D. roller bearing sheaves.)
- 110 t hook block, 1 700 kg, with five 622 mm Nominal O.D. roller bearing sheaves. (120 USt hook block, 3,760 lb with five 24" Nominal O.D. roller bearing sheaves.)
- Optional: Detachable upper boom point with one 575 mm (22.6") Nominal outer diameter roller bearing steel sheave grooved for 26mm rope for liftcrane.

Travel kit
Custom color

Working weight

Approximately 99,000 kg (218,000 lb) including upperworks and lowerworks, full upper counterweights and 15,2 m (50') basic boom.

Ground pressure

Approximately 92.9 kPa (13.5 psi) with basic boom and no load.

Gradeability

With basic boom: 30%.

Outline dimensions

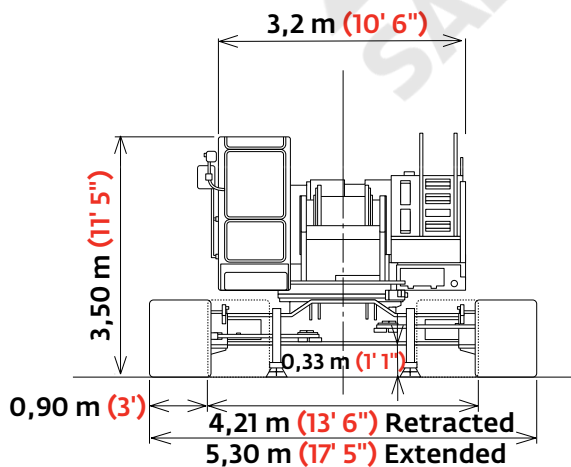
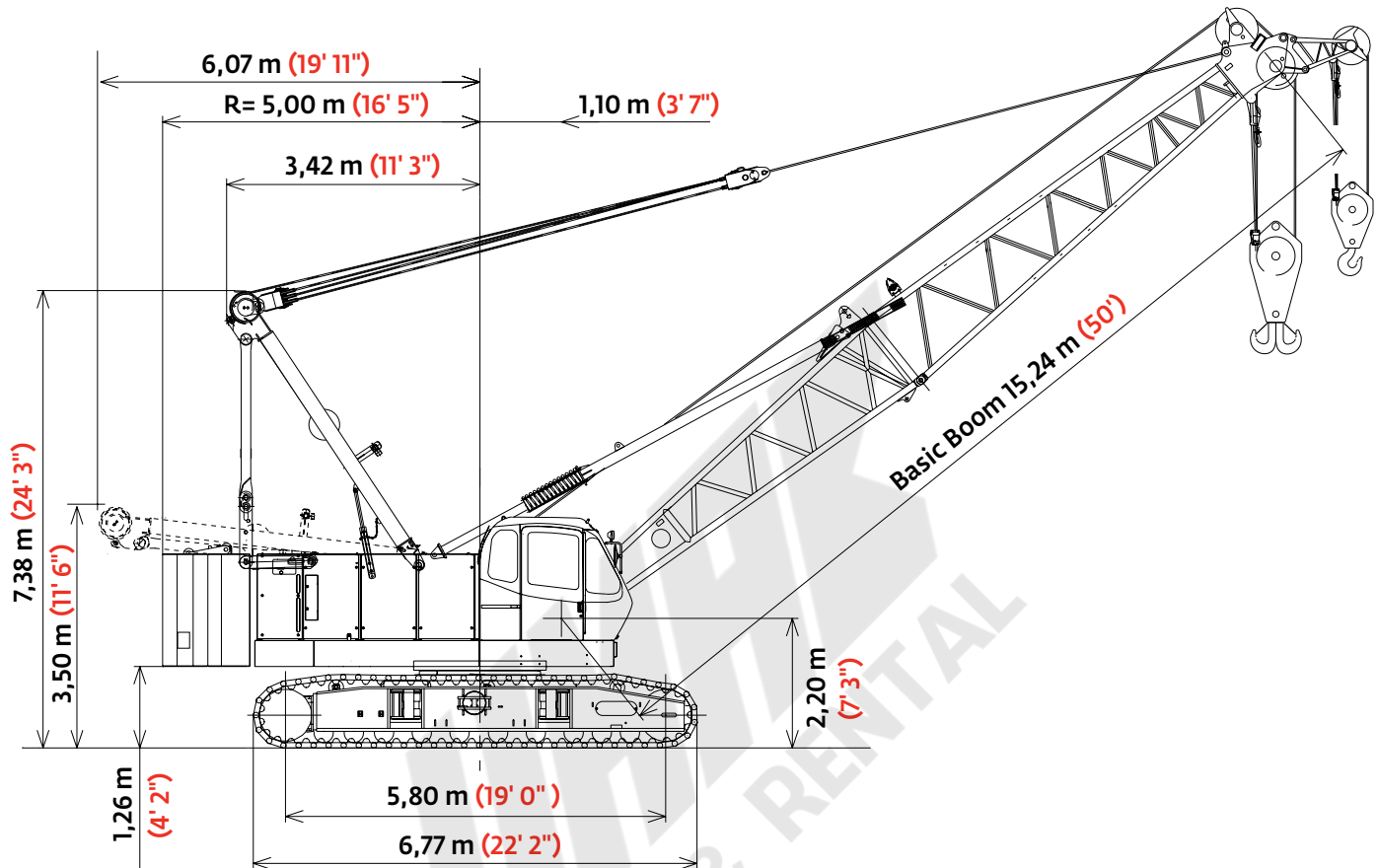

Outline dimensions

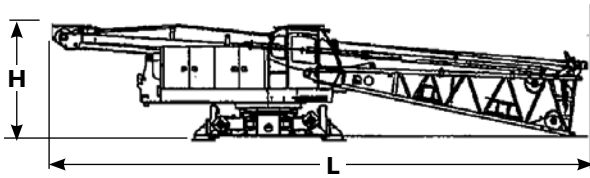

Upperworks without crawlers x1

| | | |
|--------|-----------|-----------|
| Length | 15,12 m | 49' 7" |
| Width | 3,24 m | 10' 8" |
| Height | 3,15 m | 10' 4" |
| Weight | 42 661 kg | 94,052 lb |

Note: Weight includes base machine, gantry, maximum hoist and whip lines on drums, boom butt, full hydraulic fluid reservoir, and one-third tank of fuel.

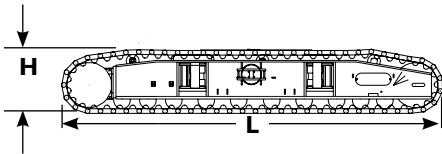

Crawlers x2

| | | |
|--------|-----------|-----------|
| Length | 6,77 m | 22' 3" |
| Width | 0,90 m | 3' 0" |
| Height | 1,15 m | 3' 9" |
| Weight | 11 830 kg | 26,085 lb |

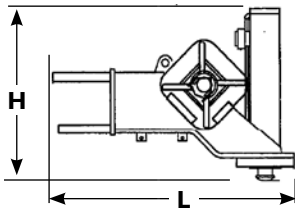

Hydraulic jack (if removed) x4

| | | |
|--------|--------|--------|
| Length | 1,36 m | 4' 5" |
| Width | 0,32 m | 1' 1" |
| Height | 0,96 m | 3' 2" |
| Weight | 430 kg | 950 lb |

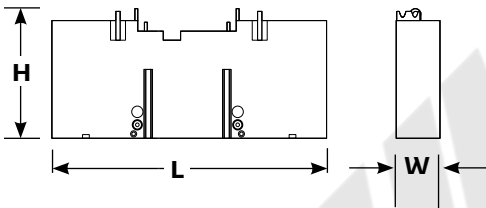

Upper counterweight A x1

| | | |
|--------|-----------|-----------|
| Length | 3,20 m | 10' 5" |
| Width | 0,58 m | 1' 11" |
| Height | 1,94 m | 6' 4" |
| Weight | 10 000 kg | 22,050 lb |

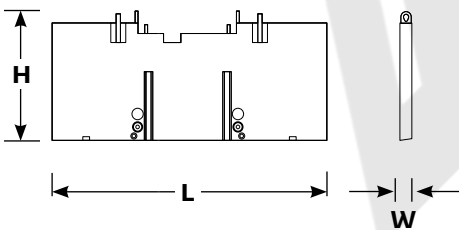

Upper counterweight B x2

| | | |
|--------|----------|-----------|
| Length | 3,20 m | 10' 5" |
| Width | 0,49 m | 1' 7" |
| Height | 1,92 m | 6' 3" |
| Weight | 7 000 kg | 15,435 lb |

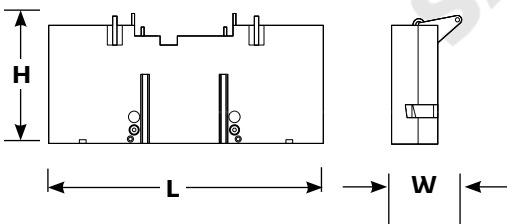

Upper counterweight C x1

| | | |
|--------|-----------|-----------|
| Length | 3,20 m | 10' 5" |
| Width | 0,69 m | 2' 3" |
| Height | 1,92 m | 6' 3" |
| Weight | 10 000 kg | 22,050 lb |

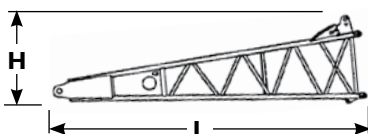

Boom butt 7,6 m (25 ft) x1

| | | |
|--------|----------|----------|
| Length | 7,79 m | 26' 3" |
| Width | 1,68 m | 5' 6" |
| Height | 2,06 m | 6' 9" |
| Weight | 2 110 kg | 4,652 lb |

Option

Outline dimensions

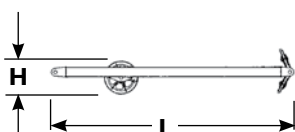
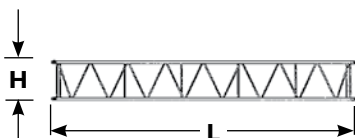
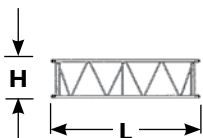
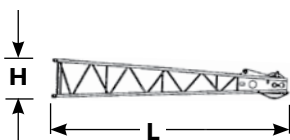
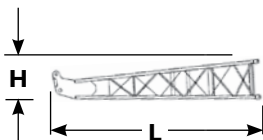
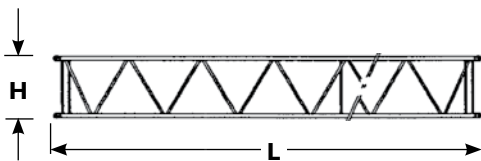
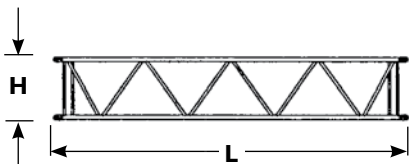
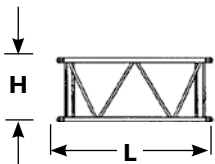
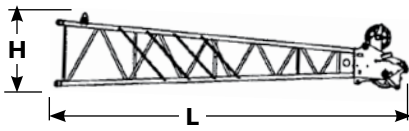

| Boom top 7,6 m (25 ft) | | x 1 |
|------------------------|----------|----------|
| Length | 8,32 m | 27' 4" |
| Width | 1,68 m | 5' 6" |
| Height | 1,69 m | 5' 7" |
| Weight | 1 525 kg | 3,362 lb |

| Boom insert 3,0 m (10 ft) | | x 1,2 |
|---------------------------|--------|--------|
| Length | 3,17 m | 10' 5" |
| Width | 1,68 m | 5' 6" |
| Height | 1,69 m | 5' 7" |
| Weight | 380 kg | 838 lb |

| Boom insert 6,1 m (20 ft) | | x 1,2 |
|---------------------------|--------|----------|
| Length | 6,22 m | 20' 5" |
| Width | 1,68 m | 5' 6" |
| Height | 1,69 m | 5' 7" |
| Weight | 655 kg | 1,445 lb |

| Boom insert 12,2 m (40 ft) | | x 1,2,3 |
|----------------------------|----------|----------|
| Length | 12,31 m | 40' 5" |
| Width | 1,68 m | 5' 6" |
| Height | 1,69 m | 5' 7" |
| Weight | 1 195 kg | 2,635 lb |

Note: Use of one "A" type insert with lug required for any boom combinations that require a 12,2 m (40') insert.

| Fixed jib butt | | x 1 |
|----------------|--------|--------|
| Length | 4,81 m | 15' 9" |
| Width | 0,80 m | 2' 8" |
| Height | 0,80 m | 2' 8" |
| Weight | 200 kg | 440 lb |

| Fixed jib top | | x 1 |
|---------------|--------|--------|
| Length | 4,91 m | 16' 1" |
| Width | 0,80 m | 2' 8" |
| Height | 0,80 m | 2' 8" |
| Weight | 280 kg | 617 lb |

| Fixed jib insert 3,0 m (10 ft) | | x 1,2 |
|--------------------------------|--------|--------|
| Length | 3,12 m | 10' 3" |
| Width | 0,80 m | 2' 8" |
| Height | 0,80 m | 2' 8" |
| Weight | 100 kg | 220 lb |

| Fixed jib insert 6,1 (20 ft) | | x 1,2 |
|------------------------------|--------|--------|
| Length | 6,16 m | 20' 3" |
| Width | 0,80 m | 2' 8" |
| Height | 0,80 m | 2' 8" |
| Weight | 180 kg | 395 lb |

| Fixed jib strut | | x 1 |
|-----------------|--------|---------|
| Length | 3,62 m | 11' 11" |
| Height | 0,62 m | 2' 0" |
| Weight | 250 kg | 550 lb |

Option

Outline dimensions

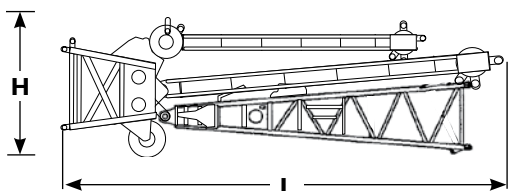
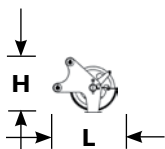
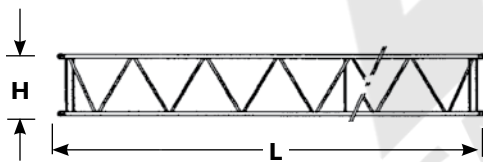
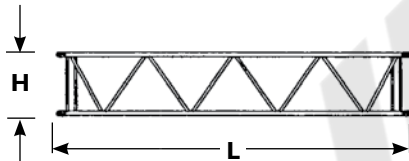
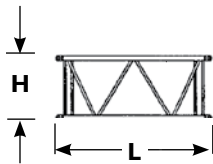
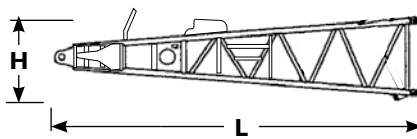
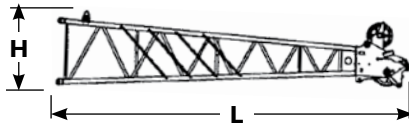
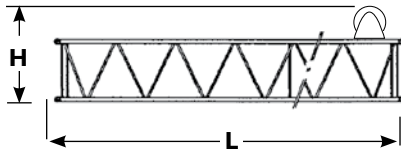

▶ **Special luffing boom insert**
9,1 m (30 ft) x1

| | | |
|--------|---------|----------|
| Length | 9,27 m | 30' 5" |
| Width | 1,68 m | 5' 6" |
| Height | 2,41 m | 7' 11" |
| Weight | 1160 kg | 2,558 lb |

▶ **Luffing jib top** x1

| | | |
|--------|---------|----------|
| Length | 6,91 m | 22' 8" |
| Width | 1,50 m | 4' 11" |
| Height | 1,48 m | 4' 10" |
| Weight | 1170 kg | 2,580 lb |

▶ **Luffing jib butt** x1

| | | |
|--------|--------|----------|
| Length | 5,97 m | 19' 7" |
| Width | 1,49 m | 4' 11" |
| Height | 1,32 m | 4' 4" |
| Weight | 836 kg | 1,903 lb |

▶ **Luffing jib insert 3,0 m (10 ft)** x1,2

| | | |
|--------|--------|--------|
| Length | 3,16 m | 10' 5" |
| Width | 1,49 m | 4' 11" |
| Height | 1,29 m | 4' 3" |
| Weight | 310 kg | 684 lb |

▶ **Luffing jib insert 6,1 m (20 ft)** x1,2

| | | |
|--------|--------|----------|
| Length | 6,21 m | 20' 5" |
| Width | 1,49 m | 4' 11" |
| Height | 1,29 m | 4' 3" |
| Weight | 540 kg | 1,147 lb |

▶ **Luffing jib insert 12,2 m (40 ft)** x1,2,3

| | | |
|--------|---------|----------|
| Length | 12,31 m | 40' 4" |
| Width | 1,49 m | 4' 11" |
| Height | 1,29 m | 4' 3" |
| Weight | 960 kg | 2,117 lb |

▶ **Luffing jib point roller assembly** x1

| | | |
|--------|--------|--------|
| Length | 1,01 m | 3' 4" |
| Width | 0,89 m | 2' 11" |
| Height | 0,91 m | 3' 0" |
| Weight | 380 kg | 838 lb |

▶ **Luffing boom top assembly (Shipping style)** x1

| | | |
|--------|----------|----------|
| Length | 8,19 m | 26' 10" |
| Height | 2,65 m | 8' 8" |
| Weight | 3 580 kg | 7,895 lb |

▶ Option

Transport data

Trailer load out summary

12000 fixed jib 21,3 m (70 ft) on 12000 boom 70,1 m (230 ft)

| Item | Weight each item kg (lb) | Quantity on trailer load # | | | | | |
|--|--------------------------------|-------------------------------|--------------------|--------------------|-------------------|--------------------|--------------------|
| | | 1 | 2 | 3 | 4 | 5 | 6 |
| 12000 basic crane with crawlers removed | 42 661 (94,052) | 1 | | | | | |
| Crawler frame | 11 832 (26,085) | | 1 | | | | |
| Crawler frame | 11 832 (26,085) | | | 1 | | | |
| Counterweight A | 10 000 (22,050) | | | | | 1 | |
| Counterweight B | 7 000 (15,435) | | | | 1 | | |
| Counterweight B | 7 000 (15,435) | | | | | 1 | |
| Counterweight C | 10 000 (22,050) | | | | | | 1 |
| 12,2 m (40 ft) boom insert, pendants | 1 195 (2,635) | | 1 | | | | |
| 12,2 m (40 ft) boom insert, pendants | 1 195 (2,635) | | | 1 | | | |
| 12,2 m (40 ft) boom insert, pendants | 1 195 (2,635) | | | | 1 | | |
| 6,1 m (20 ft) boom insert, pendants | 655 (1,445) | | | | | 1 | |
| 6,1 m (20 ft) boom insert, pendants | 655 (1,445) | | | | | | 1 |
| 3,0 m (10 ft) boom insert, pendants | 380 (838) | | 1 | | | | |
| 3,0 m (10 ft) boom insert, pendants | 380 (838) | | | | | 1 | |
| Standard boom top 7,6 m (25 ft) | 1,525 (3,362) | | | | | | 1 |
| Upper boom point | 501 (1,105) | | | 1 | | | |
| 4,6 m (15 ft) fixed jib top | 280 (617) | | | | 1 | | |
| 4,6 m (15 ft) fixed jib butt | 200 (440) | | | | | | 1 |
| 6,1 m (20 ft) fixed jib insert | 180 (395) | | | | 1 | | |
| 6,1 m (20 ft) fixed jib insert | 180 (395) | | | | | | 1 |
| Approximate total Shipping weight kg (lb) | | 42 661 (94,052) | 13 407 (29,558) | 13 528 (29,825) | 8 655 (19,082) | 18 035 (39,768) | 12 560 (27,692) |
| | | 1 | 2 | 3 | 4 | 5 | 6 |

Crane assembly

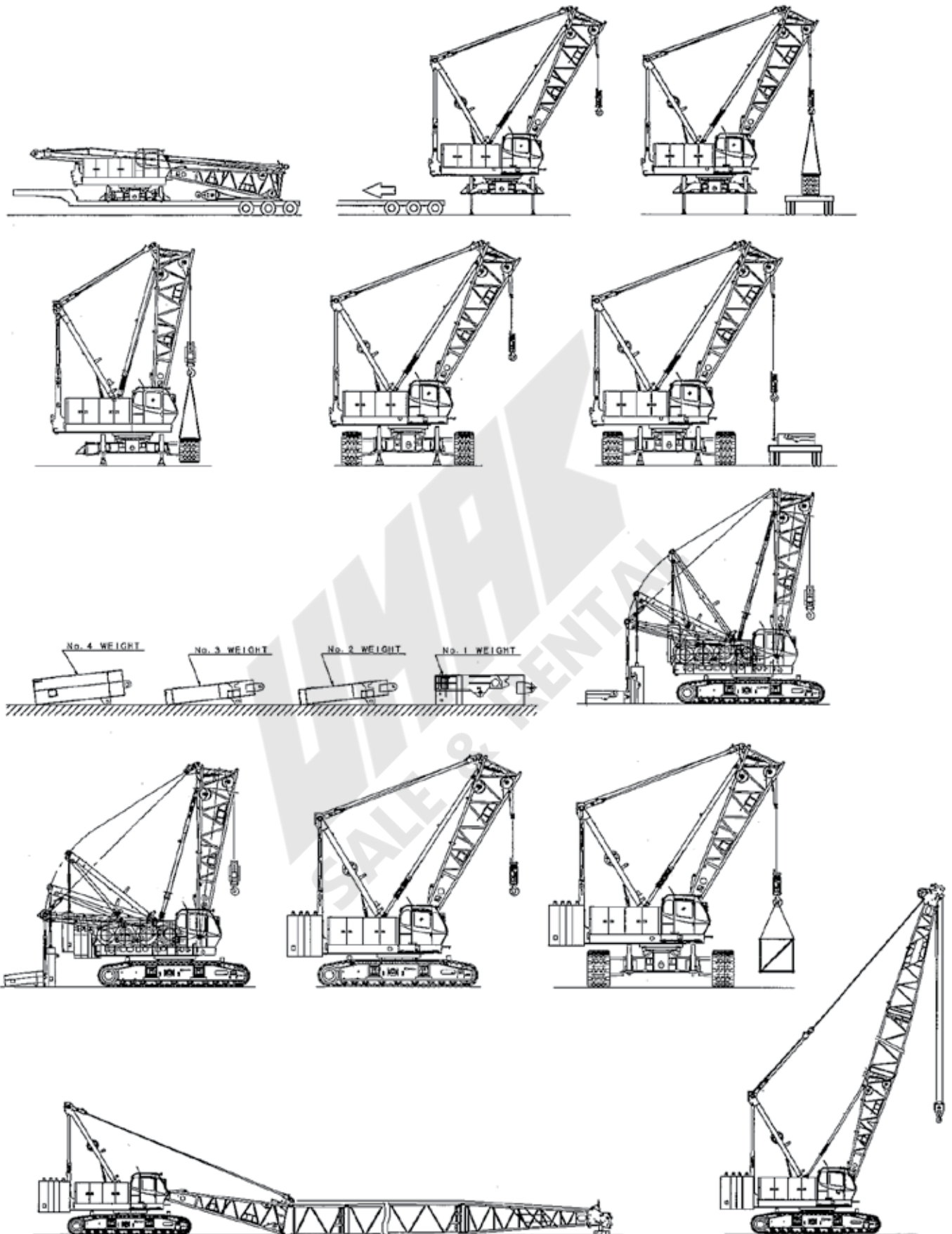

Performance data

| Line pull | | |
|-------------------|----------------------------|-------------------------------|
| | Rated line pull kg (lb) | *Maximum line pull kg (lb) |
| Front drum | 11 400 (25,100) | 21 180 (46,700) |
| Rear drum | 11 400 (25,100) | 21 180 (46,700) |
| Optional 3rd drum | 11 400 (25,100) | 21 180 (46,700) |

* Maximum line pull is not based on wire rope strength.

| Wire rope specifications | | | | |
|--------------------------|-------------------------|----------------|-----------------------------|---------------------------------|
| Use | Specs | Diameter mm | Working length m (ft) | Breaking strength kg (lb) |
| Front drum | IWRC 6 X Fi (29) C/O | 26,0 | 260 (853) | 54 431 (120,000) |
| Rear drum | IWRC 6 X Fi (29) C/O | 26,0 | 230 (754) | 54 431 (120,000) |
| Boom hoist drum | IWRC 6 X WS (31) C/O | 20,0 | 155 (508) | 33 430 (73,700) |

| Front and rear winch performance (optional: third winch) | | | | | | |
|--|------------------------------|--------------|--------------|--------------|--------------|--------------|
| Layer | Line speed m/min (ft/min) | | | | | |
| | 1 | 2 | 3 | 4 | 5 | 6 |
| Single line pull kg (lb) | | | | | | |
| 0 (0) | 120 (394) | 129 (422) | 137 (450) | 146 (479) | 155 (505) | 163 (535) |
| 2 268 (5,000) | 118 (387) | 126 (415) | 135 (443) | 143 (471) | 152 (499) | 160 (526) |
| 4 536 (10,000) | 108 (353) | 108 (353) | 108 (353) | 108 (353) | 108 (353) | 108 (353) |
| 6 804 (15,000) | 72 (235) | 72 (235) | 72 (235) | 72 (235) | 72 (235) | 72 (235) |
| 9 072 (20,000) | 52 (117) | 52 (117) | 52 (117) | 52 (117) | 52 (117) | 52 (117) |
| 11 340 (25,000) | 43 (141) | 43 (141) | 43 (141) | 43 (141) | 43 (141) | 43 (141) |
| 13 608 (30,000) | 36 (118) | 36 (118) | 36 (119) | 37 (121) | 37 (122) | 37 (123) |
| 15 876 (35,000) | 31 (103) | 32 (104) | 32 (105) | 32 (105) | – | – |
| 18 144 (40,000) | 28 (92) | 28 (92) | – | – | – | – |

NOTE: Line speeds and line pull based on single line.
Line pulls are not based on wire rope strength.

Load chart notes

- Rated loads included in the charts are the maximum allowable freely suspended loads at a given boom length, boom angle and load radius, and have been determined for the machine standing level on firm supporting surface under ideal operating conditions. The user must limit or de-rate rated loads to allow for adverse conditions (such as soft or uneven ground, out-of-level conditions, wind, side loads, pendulum action, jerking or sudden stopping of loads, inexperience of personnel, multiple machine lifts, and traveling with a load).
- Capacities do not exceed 75% of minimum tipping loads. Capacities based on factors other than machine stability such as structural competence are shown by asterisk * in the charts located in the operator's crane cab.
- The machine must be reeved and set-up as stated in the operation manual and all the instruction manuals. If these manuals are missing, obtain replacements. Boom backstops are required for all boom lengths. Gantry must be in the fully raised position for all operations. Crawlers must be fully extended and be locked in position. The crane must be leveled to within 1% on a firm supporting surface.
- Do not attempt to lift where no radius or load is listed as crane may tip or collapse.
- Attempting to lift more than rated loads may cause machine to tip or collapse. Do not tip machine to determine capacity.
- Weight of hooks, hook blocks, slings and other lifting devices are a part of the total load. Their total weight must be subtracted from the rated load to obtain the weight that can be lifted.
- When lifting over boom point with jib or upper boom point installed, rated loads for the boom must be deducted as shown below.

| Jib length m (ft) | Upper boom point | 9,1 (30) | 12,2 (40) | 15,2 (50) | 18,3 (60) | 21,3 (70) |
|-------------------|------------------|--------------|--------------|--------------|--------------|--------------|
| Deduct kg (lb) | 318 (700) | 1100 (2,400) | 1500 (3,200) | 2000 (4,200) | 2400 (5,200) | 2900 (6,200) |

When lifting over luffing jib point with luffing jib roller assembly or pin connected boom point sheave (on the luffing boom top) attached, rated loads for the jib and sheave must be deducted as shown below.

| | Luffing jib point roller | Pin connected boom point sheave |
|----------------|--------------------------|---------------------------------|
| Deduct kg (lb) | 386 (850) | 218 (480) |

- The total load that can be lifted by the fixed jib is limited by rated jib loads. The total load that can be lifted with the upper boom point is limited by rated upper boom point loads.
- Boom lengths for fixed jib mounting are 27,4 m (90 ft) to 61,0 m (200 ft).
- The total load that can be lifted by the upper boom point is: the rated load for the luffing jib (without upper boom point installed) minus 386 kg (850 lb);

however, the upper boom point rated load should not exceed 11 300 kg (25,000 lb).

- An upper boom point cannot be used on a 70,1 m (230 ft) boom length.
- The boom should be erected over the front of the crawlers, not laterally.
- Least stable position is over the side.
- Maximum hoist load for number of reeving parts of line for hoist rope.

Maximum load for main boom

| No. of parts of line | 1 | 2 | 3 | 4 | 5 |
|-----------------------|-----------------|-----------------|-----------------|------------------|------------------|
| Maximum loads kg (lb) | 11 300 (25,000) | 22 600 (50,000) | 33 900 (75,000) | 45 200 (100,000) | 56 500 (125,000) |

| No. of parts of line | 6 | 7 | 8 | 9 | 10 |
|-----------------------|------------------|------------------|------------------|-------------------|-------------------|
| Maximum loads kg (lb) | 67 800 (150,000) | 79 100 (175,000) | 90 400 (200,000) | 101 700 (225,000) | 110 000 (240,000) |

Maximum load for luffing jib

| No. of parts of line | 1 | 2 | 3 | 4 |
|-----------------------|-----------------|-----------------|-----------------|-----------------|
| Maximum loads kg (lb) | 11 300 (25,000) | 22 600 (50,000) | 33 900 (75,000) | 36 200 (80,000) |

Maximum load for fixed jib

| No. of parts of line | 1 |
|-----------------------|-----------------|
| Maximum loads kg (lb) | 10 800 (24,000) |

Maximum load for upper boom point (on liftcrane boom)

| No. of parts of line | 1 | 2 |
|-----------------------|-----------------|-----------------|
| Maximum loads kg (lb) | 11 300 (25,000) | 22 600 (50,000) |

Maximum load for upper boom point (on luffing jib)

| No. of parts of line | 1 |
|-----------------------|-----------------|
| Maximum loads kg (lb) | 11 300 (25,000) |

Minimum weight of hook block required for lowering. (Luffing jib use)

| No. of parts of line | 1 | 2 | 3 | 4 |
|------------------------|-----------|-------------|-------------|-------------|
| Maximum weight kg (lb) | 272 (600) | 544 (1,200) | 680 (1,500) | 800 (1,800) |

- Lifting capacities listed apply only to the machine as originally manufactured for and supplied by Manitowoc Cranes, Inc. Modifications to this machine or use of equipment other than that specified can reduce operating capacity.
- Designed and rated to comply with ANSI Code B30.5.

Operation of this equipment in excess of rated loads or disregard of instruction voids the warranty.

Boom combinations

No. 12000 heavy-lift boom combinations

| Boom length m (ft) | Boom inserts | | |
|-----------------------|------------------|------------------|-------------------|
| | 3,1 m (10 ft) | 6,1 m (20 ft) | 12,2 m (40 ft) |
| 15,2 (50) | – | – | – |
| 18,3 (60) | 1 | – | – |
| 21,3 (70) | 2 | 1 | – |
| 24,4 (80) | 1 | 1 | – |
| 27,4 (90) | 2 | 1 | – |
| 30,5 (100) | 1 | 2 | – |
| 33,5 (110) | 2 | 2 | – |
| 36,6 (120) | 1 | 1 | 1* |
| 39,6 (130) | 2 | 1 | 1* |
| 42,7 (140) | 1 | 2 | 1* |
| 45,7 (150) | 2 | 2 | 1* |
| 48,8 (160) | 1 | 1 | 2* |
| 51,8 (170) | 2 | 1 | 2* |
| 54,9 (180) | 1 | 2 | 2* |
| 57,9 (190) | 2 | 2 | 2* |
| 61,0 (200) | 1 | 1 | 3* |
| 64,0 (210) | 2 | 1 | 3* |
| 67,0 (220) | 1 | 2 | 3* |
| 70,1 (230) | 2 | 2 | 3* |

* NOTE: One 40 ft (12,2 m) boom insert with lug 40A is required for fixed jib. When no jib is installed a 40 ft (12,2 m) boom can be used instead of 40A.

No. 12000 fixed jib combinations

| Fixed jib length m (ft) | Fixed jib inserts | |
|----------------------------|-------------------|------------------|
| | 3,1 m (10 ft) | 6,1 m (20 ft) |
| 9,1 (30) | – | – |
| 12,2 (40) | 1 | – |
| 15,2 (50) | – | 1 |
| 18,3 (60) | 1 | 1 |
| 21,3 (70) | – | 2 |

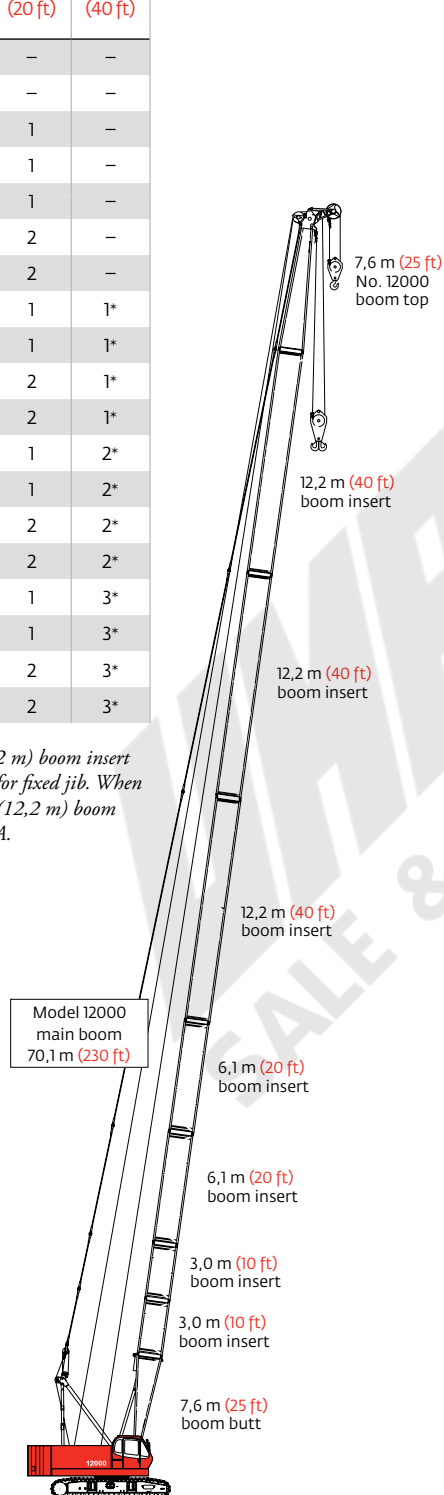

**Model 12000
Main boom
70,1 m (230 ft)**

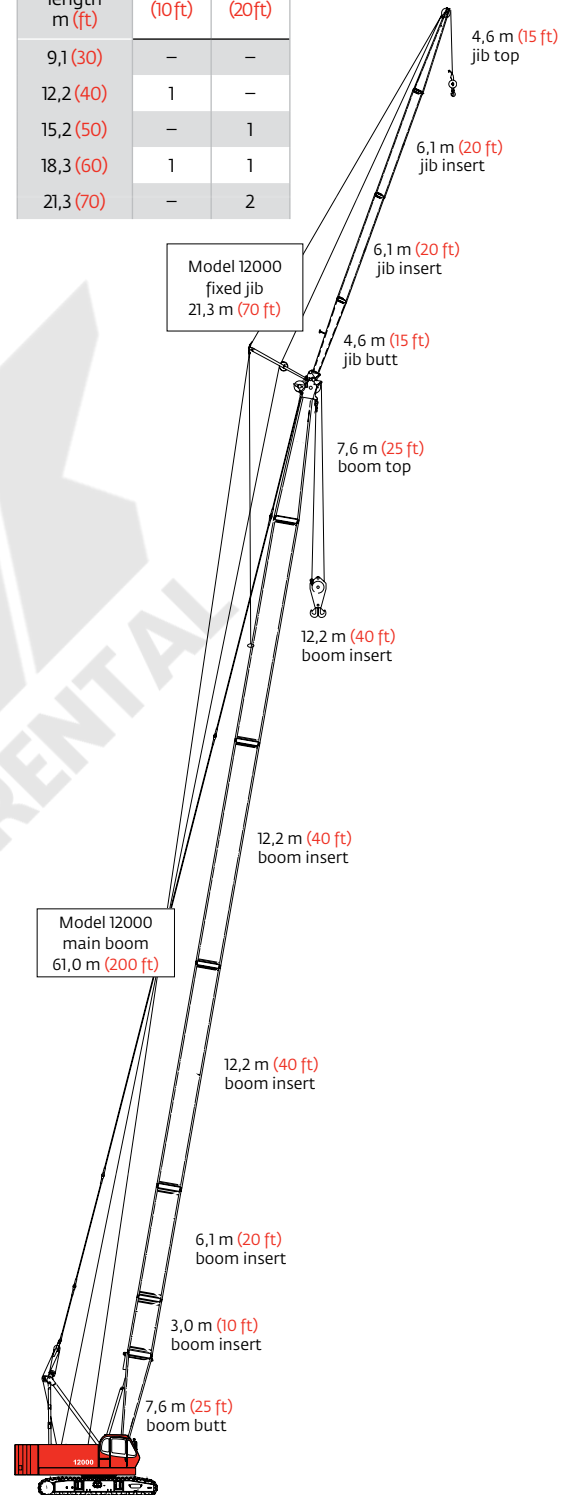

**Model 12000
Fixed jib on main boom
82,3 m (270 ft)**

Boom combinations

No. 12000 luffing jib combinations

| Boom length m (ft) | Boom inserts | | |
|-----------------------|-----------------|-----------------|------------------|
| | 3,0m (10 ft) | 6,1m (20 ft) | 12,2m (40 ft) |
| 18,3 (60) | – | – | – |
| 21,3 (70) | 1 | – | – |
| 24,4 (80) | 2 | – | – |
| 27,4 (90) | 1 | 1 | – |
| 30,5 (100) | 2 | 1 | – |
| 33,5 (110) | 1 | – | 1 |
| 36,6 (120) | 2 | – | 1 |
| 39,6 (130) | 1 | 1 | 1 |
| 42,7 (140) | 2 | 1 | 1 |
| 45,7 (150) | 1 | – | 2 |
| 48,8 (160) | 2 | – | 2 |
| 51,8 (170) | 1 | 1 | 2 |

No. 12000 luffing boom combinations

| Boom length m (ft) | Boom inserts | | | |
|-----------------------|-----------------|-----------------|-----------------|------------------|
| | 3,0m (10 ft) | 6,1m (20 ft) | 9,1m (30 ft) | 12,2m (40 ft) |
| 18,3 (60) | – | – | 1* | – |
| 21,3 (70) | 1 | – | 1* | – |
| 24,3 (80) | 2 | – | 1* | – |
| 27,4 (90) | 1 | 1 | 1* | – |
| 30,5 (100) | 2 | 1 | 1* | – |
| 33,5 (110) | 1 | 2 | 1* | – |
| 36,6 (120) | 2 | 2 | 1* | – |
| 39,6 (130) | 1 | 1 | 1* | 1 |
| 42,7 (140) | 2 | 1 | 1* | 1 |
| 45,7 (150) | 1 | 2 | 1* | 1 |

NOTE: One 9,14 m (30') special luffing boom insert is required for luffing boom.

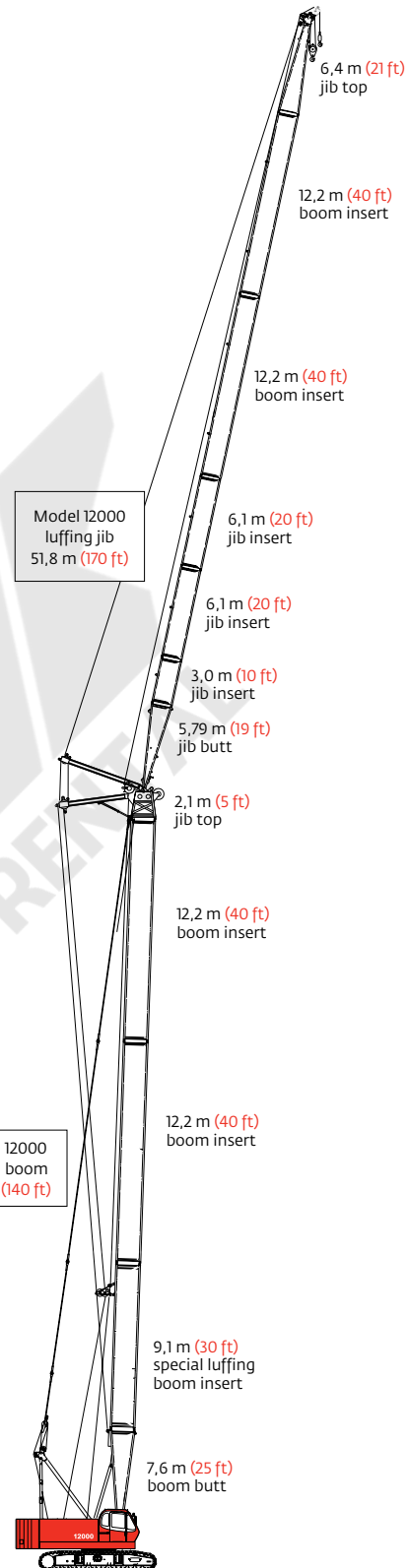

Model 12000
Luffing jib on luffing boom
94,5 m (310 ft)

Heavy-lift boom range diagram

No. 12000 main boom

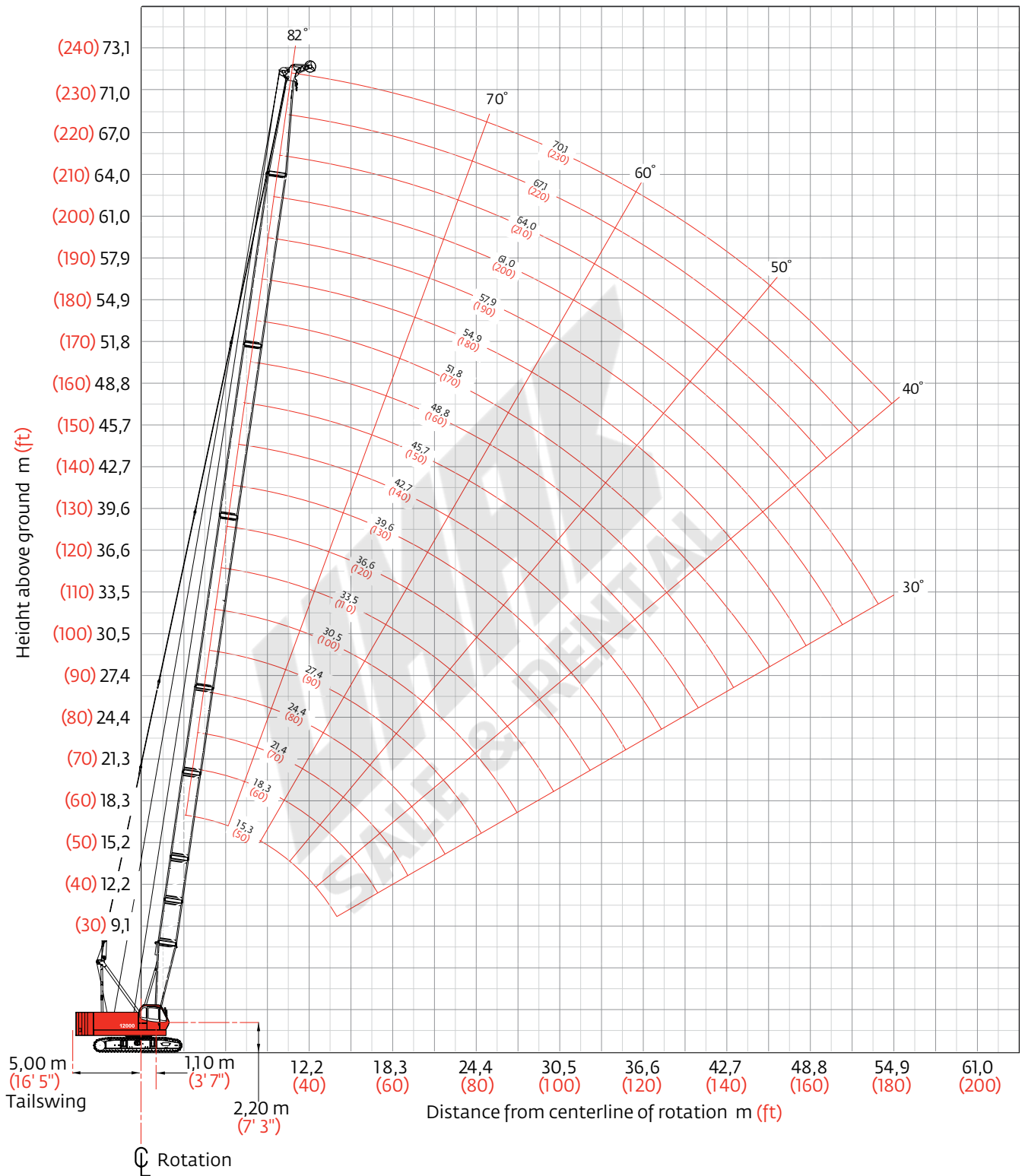

Heavy-lift boom load charts

Model 12000 liftcrane boom capacities - No. 12000 main boom

34 000 kg (75,000 lb) upper counterweight

360° Rating

kg (lb) x 1 000

| Boom m (ft) | 15,2 (50) | 18,3 (60) | 21,3 (70) | 24,4 (80) | 27,4 (90) | 30,5 (100) | 33,5 (110) | 36,6 (120) | 39,6 (130) | 42,7 (140) | 45,7 (150) | 48,8 (160) | 51,8 (170) | 54,9 (180) | 57,9 (190) | 61,0 (200) | 64,0 (210) | 67,1 (220) | 70,1 (230) |
|-------------------|------------------|-----------------|-----------------|-----------------|-----------------|-----------------|-----------------|-----------------|----------------|----------------|----------------|----------------|----------------|----------------|----------------|----------------|----------------|----------------|----------------|
| Radius | | | | | | | | | | | | | | | | | | | |
| 3,6 (12) | 110,0 (240.0) | | | | | | | | | | | | | | | | | | |
| 4,0 (14) | 99,1 (206.0) | — (204.0) | | | | | | | | | | | | | | | | | |
| 4,5 (16) | 88,4 (177.0) | 87,6 (177.0) | 86,2 (177.0) | | | | | | | | | | | | | | | | |
| 5,5 (18) | 68,0 (150.0) | 67,9 (150.0) | 67,9 (150.0) | 68,0 (150.0) | 67,9 (150.0) | | | | | | | | | | | | | | |
| 6,0 (20) | 62,0 (135.0) | 61,9 (135.0) | 61,9 (135.0) | 62,0 (135.0) | 61,9 (135.0) | 61,9 (135.0) | | | | | | | | | | | | | |
| 7,0 (24) | 53,6 (111.9) | 53,6 (111.7) | 53,6 (111.7) | 53,6 (111.5) | 53,6 (111.5) | 53,1 (111.3) | 53,0 (111.3) | 53,3 (111.1) | — (100.0) | | | | | | | | | | |
| 8,0 (28) | 44,5 (89.5) | 44,3 (89.2) | 44,3 (89.0) | 44,3 (88.8) | 44,3 (88.8) | 44,2 (88.6) | 44,1 (88.4) | 44,1 (88.4) | 44,0 (88.1) | 43,9 (87.9) | — (87.7) | | | | | | | | |
| 10,0 (34) | 32,8 (68.3) | 32,2 (68.1) | 32,2 (67.9) | 32,2 (67.4) | 32,2 (67.4) | 32,1 (67.2) | 32,0 (67.0) | 32,0 (67.0) | 31,9 (66.7) | 31,8 (66.5) | 31,7 (66.3) | 31,7 (66.3) | 31,6 (66.1) | 31,5 (65.9) | 30,0 (65.4) | | | | |
| 12,0 (40) | 25,6 (55.1) | 25,6 (54.6) | 25,3 (54.4) | 25,3 (54.2) | 24,6 (54.0) | 24,9 (53.7) | 24,8 (53.5) | 24,8 (53.5) | 24,7 (53.3) | 24,6 (53.1) | 24,4 (52.6) | 24,5 (52.9) | 24,3 (52.4) | 24,2 (52.2) | 24,1 (52.0) | 22,6 (50.0) | 22,6 (50.0) | 21,3 (46.7) | 19,5 (42.7) |
| 14,0 (45) | — (47.1) | 20,5 (46.7) | 20,5 (46.5) | 20,5 (46.2) | 20,5 (46.0) | 20,3 (45.8) | 20,2 (45.6) | 20,2 (45.6) | 20,1 (45.4) | 20,0 (45.1) | 19,8 (44.7) | 19,9 (44.9) | 19,7 (44.5) | 19,6 (44.3) | 19,5 (44.0) | 19,5 (44.0) | 19,4 (43.8) | 19,2 (43.4) | 17,9 (40.1) |
| 16,0 (55) | | 17,0 (36.1) | 17,0 (35.9) | 17,0 (35.4) | 17,0 (35.4) | 17,0 (35.0) | 16,9 (34.8) | 16,8 (34.8) | 16,8 (34.6) | 16,6 (34.3) | 16,5 (33.9) | 16,5 (33.9) | 16,4 (33.7) | 16,2 (33.2) | 16,1 (33.0) | 16,1 (33.0) | 16,0 (32.8) | 15,9 (32.6) | 15,7 (32.1) |
| 22,0 (75) | | | | | 11,5 (23.5) | 11,0 (23.1) | 11,0 (22.9) | 10,9 (22.7) | 10,8 (22.4) | 10,6 (22.2) | 10,5 (21.8) | 10,5 (21.8) | 10,4 (21.6) | 10,2 (21.1) | 10,0 (20.9) | 10,1 (20.9) | 10,0 (20.7) | 9,8 (20.2) | 9,6 (20.0) |
| 28,0 (95) | | | | | | | 7,9 (16.5) | 7,8 (16.3) | 7,7 (16.0) | 7,5 (15.6) | 7,4 (15.4) | 7,4 (15.4) | 7,2 (14.9) | 7,0 (14.7) | 6,9 (14.3) | 6,9 (14.3) | 6,8 (14.1) | 6,7 (13.8) | 6,5 (13.4) |
| 32,0 (105) | | | | | | | | 6,4 (14.1) | 6,3 (13.8) | 6,1 (13.4) | 6,0 (13.2) | 6,0 (13.2) | 5,8 (12.7) | 5,6 (12.3) | 5,5 (12.1) | 5,5 (12.1) | 5,4 (11.9) | 5,2 (11.4) | 5,1 (11.2) |
| 34,0 (115) | | | | | | | | | 5,8 (12.1) | 5,5 (11.6) | 5,4 (11.2) | 5,4 (11.2) | 5,2 (11.0) | 5,0 (10.5) | 4,9 (10.1) | 5,0 (10.3) | 4,8 (9.9) | 4,6 (9.7) | 4,5 (9.2) |
| 38,0 (125) | | | | | | | | | | 4,7 (10.3) | 4,5 (9.9) | 4,4 (9.7) | 4,3 (9.4) | 4,1 (9.0) | 4,0 (8.8) | 4,0 (8.8) | 3,8 (8.3) | 3,6 (7.9) | 3,4 (7.4) |
| 40,0 (135) | | | | | | | | | | | | 4,1 (8.5) | 3,9 (8.1) | 3,7 (7.7) | 3,5 (7.2) | 3,5 (7.2) | 3,4 (6.8) | 3,2 (6.6) | 3,0 (6.1) |
| 44,0 (145) | | | | | | | | | | | | | 3,2 (7.0) | 3,0 (6.6) | 2,8 (6.1) | 2,8 (6.1) | 2,6 (5.7) | 2,4 (5.2) | 2,2 (4.8) |
| 46,0 (155) | | | | | | | | | | | | | | 2,7 (5.7) | 2,5 (5.2) | 2,5 (5.0) | 2,3 (4.6) | 2,1 (4.4) | 1,9 (3.9) |
| 50,0 (165) | | | | | | | | | | | | | | | 2,0 (4.4) | 1,9 (4.1) | 1,7 (3.7) | 1,6 (3.5) | |
| 53,3 (175) | | | | | | | | | | | | | | | | 1,6 (3.5) | | | |

For complete chart, refer to www.cranelibrary.com.

Meets ANSI B30.5 Requirements - Capacities do not exceed 75% of static tipping load.
 NOTICE: This capacity chart is for reference only and must not be used for lifting purposes.

Fixed jib range diagram

No. 12000 fixed jib on main boom

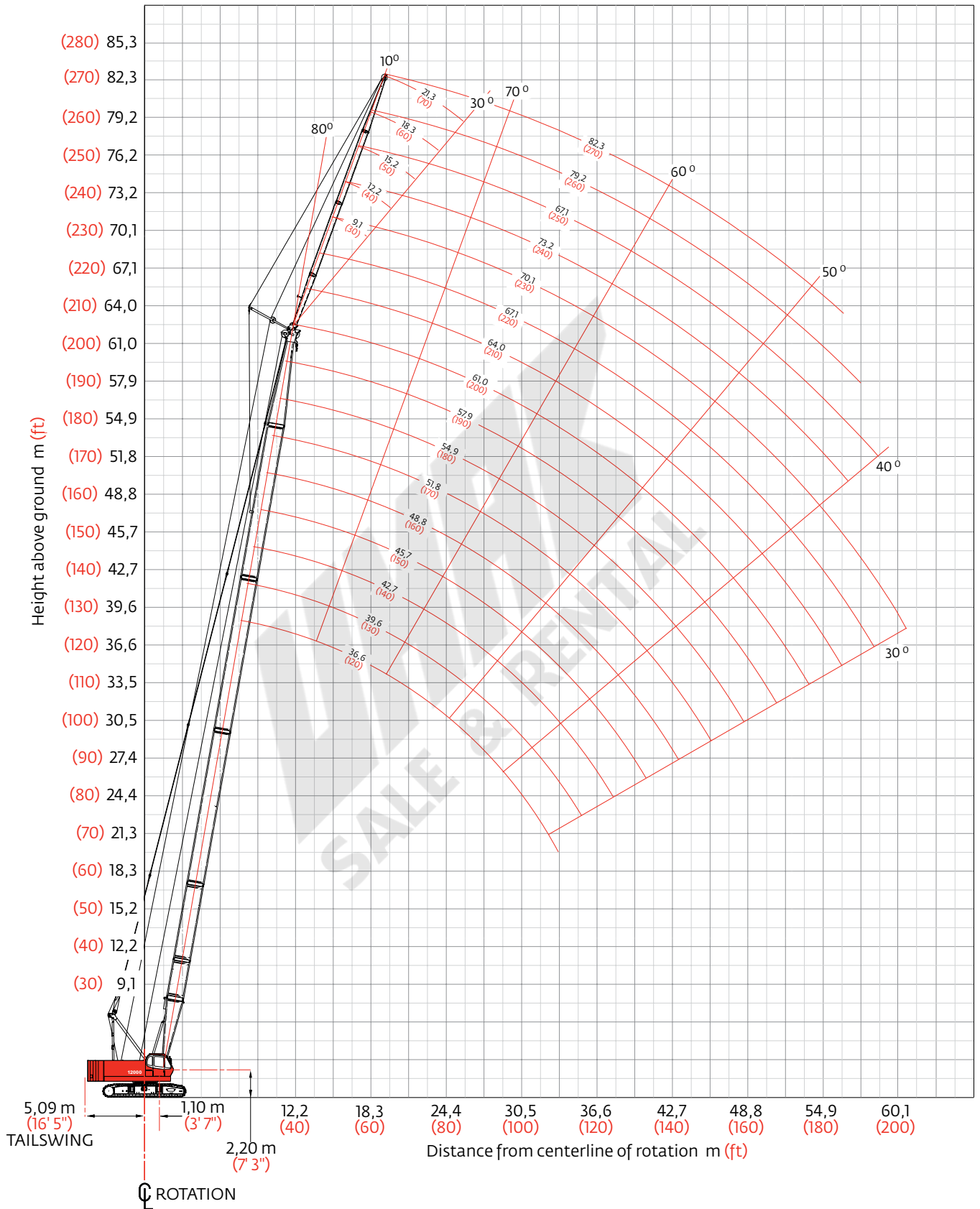

Fixed jib load charts

Model 12000 liftcrane fixed jib capacities - No. 12000 fixed jib on main boom

34 000 kg (75,000 lb) upper counterweight

360° Rating

kg (lb) x 1 000

10° offset

30° offset

| Boom m (ft) | 27,4 (90) | 36,6 (120) | 48,8 (160) | 54,9 (180) | 61,0 (200) |
|----------------|----------------|----------------|----------------|----------------|----------------|
| Radius | | | | | |
| 10,0 (30) | 10,8 (24.0) | | | | |
| 12,0 (40) | 10,8 (24.0) | 10,8 (24.0) | | | |
| 14,0 (50) | 10,8 (24.0) | 10,8 (24.0) | 10,8 (24.0) | — (24.0) | — (24.0) |
| 18,0 (60) | 10,8 (24.0) | 10,8 (24.0) | 10,8 (24.0) | 10,8 (24.0) | 10,8 (24.0) |
| 24,0 (80) | 10,1 (21.9) | 9,7 (21.1) | 9,3 (20.1) | 9,0 (19.8) | 8,8 (19.0) |
| 30,0 (100) | 7,4 (16.1) | 7,1 (15.3) | 6,6 (14.2) | 6,3 (13.6) | 6,1 (13.1) |
| 36,0 (120) | | 5,3 (11.6) | 4,8 (10.4) | 4,5 (9.8) | 4,3 (9.3) |
| 42,0 (140) | | | 3,6 (7.8) | 3,3 (7.1) | 3,0 (6.5) |
| 48,0 (160) | | | 2,7 (5.8) | 2,3 (4.9) | 2,0 (4.2) |
| 52,0 (175) | | | 2,2 (—) | 1,7 (3.6) | 1,5 (—) |
| 56,0 (185) | | | | | |

| Boom m (ft) | 27,4 (90) | 36,6 (120) | 48,8 (160) | 54,9 (180) | 61,0 (200) |
|----------------|---------------|---------------|---------------|---------------|---------------|
| Radius | | | | | |
| 10,0 (30) | | | | | |
| 12,0 (40) | — (21.0) | | | | |
| 14,0 (50) | 9,5 (21.0) | 9,5 (21.0) | | | |
| 18,0 (60) | 9,5 (21.0) | 9,5 (21.0) | 9,5 (21.0) | 9,5 (21.0) | — |
| 24,0 (80) | 8,6 (18.9) | 9,4 (20.8) | 9,4 (20.8) | 9,2 (20.2) | 9,1 (19.9) |
| 30,0 (100) | | 7,2 (15.6) | 6,8 (14.7) | 6,5 (14.1) | 6,4 (13.7) |
| 36,0 (120) | | | 5,0 (10.7) | 4,7 (10.2) | 4,5 (9.7) |
| 42,0 (140) | | | | 3,4 (7.4) | 3,2 (7.0) |
| 48,0 (160) | | | | | 2,3 (—) |
| 52,0 (175) | | | | | |
| 56,0 (185) | | | | | |

| Boom m (ft) | 27,4 (90) | 36,6 (120) | 48,8 (160) | 54,9 (180) | 61,0 (200) |
|----------------|---------------|---------------|---------------|---------------|---------------|
| Radius | | | | | |
| 10,0 (30) | 9,0 (—) | | | | |
| 12,0 (40) | 9,0 (20.0) | 9,0 (—) | | | |
| 14,0 (50) | 9,0 (20.0) | 9,0 (20.0) | 9,0 (20.0) | | |
| 18,0 (60) | 9,0 (20.0) | 9,0 (20.0) | 9,0 (20.0) | 9,0 (20.0) | 9,0 (20.0) |
| 24,0 (80) | 7,7 (16.8) | 8,9 (19.5) | 9,0 (20.0) | 9,0 (20.0) | 8,9 (19.7) |
| 30,0 (100) | 6,2 (13.6) | 7,2 (15.7) | 6,8 (14.7) | 6,5 (14.1) | 6,3 (13.6) |
| 36,0 (120) | 5,2 (11.5) | 5,5 (11.9) | 5,0 (10.8) | 4,7 (10.2) | 4,5 (9.8) |
| 42,0 (140) | | 4,3 (9.3) | 3,8 (8.2) | 3,5 (7.5) | 3,3 (7.1) |
| 48,0 (160) | | | 2,9 (6.2) | 2,5 (5.4) | 2,2 (4.7) |
| 52,0 (175) | | | 2,3 (4.9) | 1,9 (4.0) | 1,6 (3.3) |
| 58,0 (185) | | | 1,8 (4.1) | | |

| Boom m (ft) | 27,4 (90) | 36,6 (120) | 48,8 (160) | 54,9 (180) | 61,0 (200) |
|----------------|---------------|---------------|---------------|---------------|---------------|
| Radius | | | | | |
| 10,0 (30) | | | | | |
| 12,0 (40) | | | | | |
| 14,0 (50) | | | | | |
| 18,0 (60) | 5,1 (11.4) | 5,1 (11.4) | 5,1 (—) | | |
| 24,0 (80) | 5,1 (11.2) | 5,1 (11.2) | 5,1 (11.4) | 5,1 (11.4) | 5,1 (11.4) |
| 30,0 (100) | 4,4 (9.8) | 4,8 (10.6) | 5,1 (11.4) | 5,1 (11.4) | 5,1 (11.4) |
| 36,0 (120) | | 4,3 (9.6) | 4,7 (10.4) | 4,9 (10.8) | 4,9 (10.6) |
| 42,0 (140) | | | 4,0 (8.6) | 3,7 (8.1) | 3,6 (7.7) |
| 48,0 (160) | | | | 2,7 (5.9) | 2,5 (5.3) |
| 52,0 (175) | | | | | 1,9 (3.8) |
| 58,0 (185) | | | | | |

For complete chart, refer to www.cranelibrary.com.

Meets ANSI B30.5 Requirements - Capacities do not exceed 75% of static tipping load.
NOTICE: This capacity chart is for reference only and must not be used for lifting purposes.

Fixed jib load charts

Model 12000 liftcrane fixed jib capacities - No. 12000 fixed jib on main boom

34 000 kg (75,000 lb) upper counterweight

360° Rating

kg (lb) x 1 000

| 10° offset | | | | | | 30° offset | | | | | |
|-----------------------|---------------|---------------|---------------|---------------|---------------|----------------|--------------|---------------|---------------|---------------|---------------|
| Boom m (ft) | 27,4 (90) | 36,6 (120) | 48,8 (160) | 54,9 (180) | 61,0 (200) | Boom m (ft) | 27,4 (90) | 36,6 (120) | 48,8 (160) | 54,9 (180) | 61,0 (200) |
| Radius | | | | | | Radius | | | | | |
| jib 21,3 m (70 ft) | 12,0 (45) | 7,1 (15.7) | | | | 12,0 (45) | | | | | |
| | 18,0 (60) | 6,7 (14.8) | 6,8 (15.1) | 6,9 (15.4) | 7,0 (15.6) | 7,1 (15.7) | 3,6 (—) | | | | |
| | 22,0 (75) | 6,4 (13.9) | 6,6 (14.4) | 6,7 (14.8) | 6,8 (15.0) | 6,9 (15.1) | 3,6 (8.1) | 3,6 (8.1) | | | |
| | 26,0 (90) | 5,5 (11.5) | 6,3 (13.3) | 6,5 (14.3) | 6,6 (14.4) | 6,7 (14.6) | 3,5 (7.6) | 3,6 (8.1) | 3,6 (8.1) | 3,6 (8.1) | 3,6 (8.1) |
| | 32,0 (110) | 4,4 (9.4) | 5,1 (10.9) | 6,0 (12.7) | 6,0 (12.3) | 5,8 (11.9) | 3,0 (6.5) | 3,3 (7.0) | 3,5 (7.6) | 3,6 (7.8) | 3,6 (8.0) |
| | 38,0 (130) | 3,7 (7.9) | 4,3 (9.2) | 4,7 (9.7) | 4,4 (9.1) | 4,2 (8.6) | 2,7 (—) | 2,9 (6.3) | 3,1 (6.9) | 3,2 (7.1) | 3,3 (7.3) |
| | 44,0 (145) | 3,2 (7.1) | 3,7 (8.2) | 3,6 (7.9) | 3,3 (7.2) | 3,1 (6.8) | | 2,6 (5.9) | 2,9 (6.4) | 3,0 (6.6) | 3,0 (6.8) |
| | 50,0 (170) | | 3,2 (6.8) | 2,7 (5.6) | 2,4 (4.7) | 2,0 (4.1) | | | 2,6 (5.9) | 2,7 (5.5) | 2,5 (4.9) |
| | 54,0 (180) | | | 2,2 (4.8) | 1,8 (3.9) | | | | | 2,1 (4.5) | 1,8 (3.9) |
| | 56,0 (190) | | | 2,0 (4.0) | 1,6 (—) | | | | | | 1,6 (—) |
| | 60,0 (200) | | | 1,6 (3.3) | | | | | | | |

For complete chart, refer to www.cranelibrary.com.

Meets ANSI B30.5 Requirements - Capacities do not exceed 75% of static tipping load.
 NOTICE: This capacity chart is for reference only and must not be used for lifting purposes.

Luffing jib range diagram

No. 12000 luffing jib on luffing boom

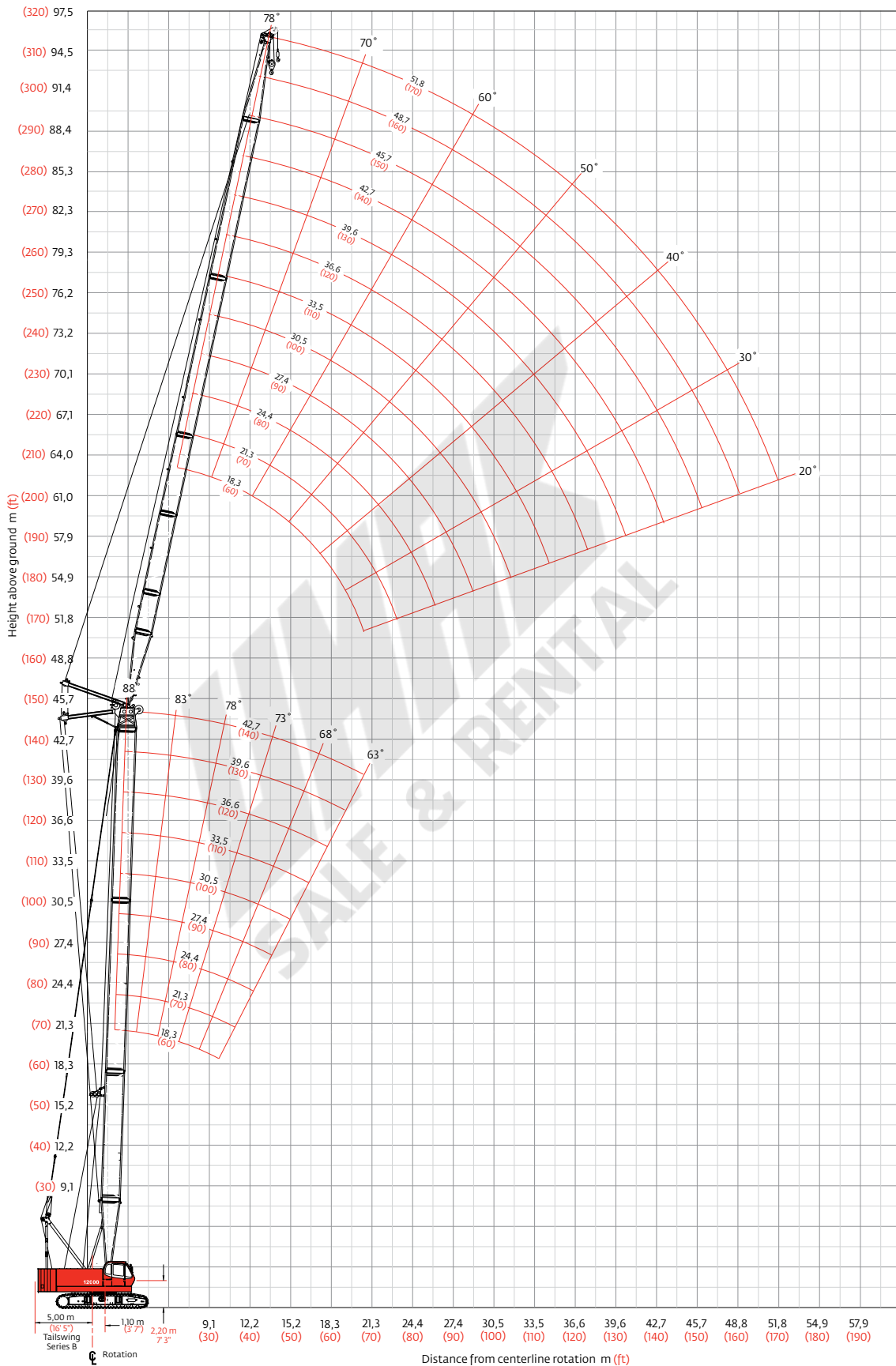

Luffing jib load charts

Model 12000 liftcrane luffing jib capacities - No. 12000 luffing jib on luffing boom

34 000 kg (75,000 lb) counterweight
360° Rating

kg (lb) x1000

88° boom angle

| | Boom m (ft) | 18,2 (60) | 24,4 (80) | 30,5 (100) | 36,6 (120) | 45,7 (150) |
|-----------------------------------|----------------|----------------|----------------|----------------|----------------|----------------|
| Luffing jib length 18,3 m (60 ft) | Radius | | | | | |
| | 7,9 (26) | 36,2 (80.0) | — (80.0) | | | |
| | 9,0 (30) | 31,9 (69.3) | 31,9 (69.3) | 31,9 (69.3) | 31,9 (69.3) | 19,5 (42.5) |
| | 10,0 (36) | 28,8 (57.7) | 28,7 (57.7) | 28,7 (57.7) | 28,7 (57.7) | 17,9 (36.4) |
| | 14,0 (45) | 20,4 (46.2) | 20,5 (46.2) | 20,5 (46.2) | 20,5 (46.2) | 12,9 (29.1) |
| | 18,0 (65) | 14,1 (—) | 14,4 (26.9) | 14,6 (27.3) | 14,8 (27.6) | 9,5 (18.3) |
| | 20,0 (80) | 11,2 (—) | 11,3 (—) | 11,5 (—) | 11,8 (—) | 7,9 (—) |
| | 24,0 (80) | | | | | |
| | 30,0 (100) | | | | | |
| | 36,0 (120) | | | | | |
| 44,0 (145) | | | | | | |

| | Boom m (ft) | 18,2 (60) | 24,4 (80) | 30,5 (100) | 36,6 (120) | 45,7 (150) |
|------------------------------------|----------------|----------------|----------------|----------------|----------------|----------------|
| Luffing jib length 30,5 m (100 ft) | Radius | | | | | |
| | 7,9 (26) | | | | | |
| | 9,0 (30) | | | | | |
| | 10,0 (36) | — (57.7) | | | | |
| | 14,0 (45) | 20,5 (46.2) | 20,5 (46.2) | 20,5 (46.2) | 20,5 (46.2) | 12,6 (28.4) |
| | 18,0 (65) | 14,7 (28.0) | 15,0 (28.4) | 15,2 (28.9) | 15,4 (29.1) | 9,6 (19.0) |
| | 24,0 (80) | 9,4 (20.3) | 9,4 (20.3) | 9,5 (20.5) | 9,6 (20.7) | 6,6 (14.3) |
| | 30,0 (100) | 6,4 (13.7) | 6,4 (13.7) | 6,4 (13.7) | 6,4 (13.7) | 4,5 (9.7) |
| | 32,0 (120) | | | 5,4 (—) | 5,5 (—) | 3,9 (—) |
| | 36,0 (120) | | | | | |
| 44,0 (145) | | | | | | |

| | Boom m (ft) | 18,2 (60) | 24,4 (80) | 30,5 (100) | 36,6 (120) |
|------------------------------------|----------------|----------------|----------------|----------------|----------------|
| Luffing jib length 39,6 m (130 ft) | Radius | | | | |
| | 14,0 (45) | 20,7 (46.2) | 20,7 (46.2) | 20,7 (46.2) | |
| | 16,0 (55) | 17,7 (36.8) | 17,9 (37.5) | 17,9 (37.5) | 17,1 (36.4) |
| | 22,0 (75) | 10,9 (22.7) | 11,0 (22.9) | 11,2 (23.1) | 11,3 (23.4) |
| | 28,0 (95) | 7,3 (15.2) | 7,4 (15.4) | 7,4 (15.4) | 7,5 (15.7) |
| | 34,0 (115) | 5,0 (10.6) | 5,1 (10.6) | 5,1 (10.6) | 5,1 (10.8) |
| | 40,0 (130) | 3,4 (8.2) | 3,4 (8.2) | 3,4 (8.2) | 3,4 (8.2) |
| | 44,0 (150) | | | | |
| | 50,0 (165) | | | | |
| | 52,0 (175) | | | | |
| 56,0 (190) | | | | | |

| | Boom m (ft) | 18,2 (60) | 24,4 (80) | 30,5 (100) | 36,6 (120) |
|------------------------------------|----------------|----------------|----------------|----------------|----------------|
| Luffing jib length 51,8 m (170 ft) | Radius | | | | |
| | 14,0 (45) | | | | |
| | 16,0 (55) | — (30.0) | — (30.2) | | |
| | 22,0 (75) | 10,3 (21.6) | 10,4 (21.8) | 10,4 (22.0) | 10,6 (22.3) |
| | 28,0 (95) | 6,8 (14.1) | 6,9 (14.3) | 6,9 (14.3) | 7,0 (14.6) |
| | 34,0 (115) | 4,6 (9.7) | 4,6 (9.7) | 4,7 (9.7) | 4,7 (9.7) |
| | 40,0 (130) | 3,2 (7.3) | 3,2 (7.3) | 3,2 (7.3) | 2,6 (6.2) |
| | 44,0 (150) | 2,6 (4.9) | 2,6 (4.0) | 1,6 (—) | |
| | 50,0 (165) | — (2.2) | | | |
| | 52,0 (175) | | | | |
| 56,0 (190) | | | | | |

For complete chart, refer to www.cranelibrary.com.

Meets ANSI B30.5 Requirements - Capacities do not exceed 75% of static tipping load.
NOTICE: This capacity chart is for reference only and must not be used for lifting purposes.

Luffing jib load charts

Model 12000 liftcrane luffing jib capacities - No. 12000 luffing jib on luffing boom

34 000 kg (75,000 lb) counterweight

360° Rating

kg (lb) x1 000

73° boom angle

| | Luffing jib length 18,3 m (60 ft) | | | | | Luffing jib length 30,5 m (100 ft) | | | | | | |
|---------------|-----------------------------------|----------------|----------------|---------------|---------------|------------------------------------|----------------|---------------|---------------|---------------|---------------|---------------|
| | Boom m (ft) | 18,2 (60) | 24,4 (80) | 30,5 (100) | 36,6 (120) | 45,7 (150) | Boom m (ft) | 18,2 (60) | 24,4 (80) | 30,5 (100) | 36,6 (120) | 45,7 (150) |
| Radius | | | | | | | | | | | | |
| 16,0 (55) | — (35.9) | | | | | | 16,0 (55) | | | | | |
| 20,0 (65) | 13,0 (29.1) | 12,4 (27.6) | | | | | 20,0 (65) | | | | | |
| 22,0 (75) | 11,5 (24.0) | 11,0 (23.1) | 10,4 (22.3) | — (20.3) | | | 22,0 (75) | | | | | |
| 26,0 (85) | | 8,5 (19.6) | 8,4 (18.7) | 8,0 (17.9) | 6,9 (15.4) | | 26,0 (85) | 8,8 (19.6) | 8,1 (17.9) | | | |
| 28,0 (95) | | | 7,4 (—) | 7,2 (15.2) | 6,6 (13.9) | | 28,0 (95) | 7,9 (16.8) | 7,5 (15.9) | 6,9 (15.0) | — (13.0) | |
| 32,0 (105) | | | | | 5,3 (11.9) | | 32,0 (105) | 6,6 (14.6) | 6,2 (13.7) | 5,8 (13.0) | 5,4 (12.1) | 4,2 (9.3) |
| 34,0 (115) | | | | | | | 34,0 (115) | 5,9 (12.8) | 5,6 (11.9) | 5,3 (11.2) | 4,9 (10.4) | 4,1 (9.0) |
| 38,0 (125) | | | | | | | 38,0 (125) | | 4,7 (—) | 4,5 (9.9) | 4,1 (9.0) | 3,5 (7.7) |
| 40,0 (135) | | | | | | | 40,0 (135) | | | | 3,8 (7.9) | 3,1 (6.6) |
| 42,0 (140) | | | | | | | 42,0 (140) | | | | | 2,8 (6.2) |

| | Luffing jib length 39,6 m (130 ft) | | | | Luffing jib length 51,8 m (170 ft) | | | | | |
|---------------|------------------------------------|---------------|---------------|---------------|------------------------------------|----------------|--------------|--------------|---------------|---------------|
| | Boom m (ft) | 18,2 (60) | 24,4 (80) | 30,5 (100) | 36,6 (120) | Boom m (ft) | 18,2 (60) | 24,4 (80) | 30,5 (100) | 36,6 (120) |
| Radius | | | | | | | | | | |
| 28,0 (95) | — (15.2) | | | | | 28,0 (95) | | | | |
| 32,0 (105) | 6,3 (13.9) | 5,8 (13.0) | — (11.2) | | | 32,0 (105) | | | | |
| 34,0 (115) | 5,7 (12.1) | 5,3 (11.2) | 5,0 (10.6) | 4,2 (9.3) | | 34,0 (115) | — (10.1) | | | |
| 38,0 (125) | 4,8 (10.6) | 4,5 (9.9) | 4,2 (9.3) | 3,7 (8.2) | | 38,0 (125) | 4,3 (9.5) | 3,8 (8.4) | — (6.6) | |
| 40,0 (135) | 4,4 (9.3) | 4,1 (8.6) | 3,8 (7.9) | 3,4 (7.1) | | 40,0 (135) | 3,9 (8.4) | 3,6 (7.5) | 2,9 (6.6) | 2,2 (4.9) |
| 44,0 (145) | 3,7 (8.2) | 3,5 (7.7) | 3,1 (6.8) | 2,8 (6.2) | | 44,0 (145) | 3,2 (7.1) | 2,9 (6.4) | 2,5 (5.5) | 2,1 (4.6) |
| 46,0 (155) | | 3,2 (—) | 2,8 (6.0) | 2,5 (5.3) | | 46,0 (155) | 2,9 (6.2) | 2,6 (5.5) | 2,2 (4.6) | 1,8 (4.0) |
| 48,0 (160) | | | 2,6 (—) | 2,3 (4.9) | | 48,0 (160) | 2,7 (5.7) | 2,4 (5.1) | 1,9 (4.2) | 1,7 (3.5) |
| 52,0 (175) | | | | | | 52,0 (175) | 2,2 (4.6) | 1,8 (4.0) | 1,5 (3.3) | |
| 56,0 (185) | | | | | | 56,0 (185) | 1,7 (—) | 1,5 (3.3) | | |

For complete chart, refer to www.cranelibrary.com.

Meets ANSI B30.5 Requirements - Capacities do not exceed 75% of static tipping load.
 NOTICE: This capacity chart is for reference only and must not be used for lifting purposes.

Luffing jib load charts

Model 12000 liftcrane luffing jib capacities - No. 12000 luffing jib on luffing boom

34 000 kg (75,000 lb) counterweight

360° Rating

kg (lb) x1000

63° boom angle

| Boom m (ft) | 18,2 (60) | 24,4 (80) | 30,5 (100) | 36,6 (120) | 45,7 (150) |
|-------------------|---------------|---------------|---------------|---------------|---------------|
| Radius | | | | | |
| 22,0 (75) | — (22.5) | | | | |
| 24,0 (80) | 9,7 (21.2) | | | | |
| 26,0 (85) | 8,6 (19.4) | 7,9 (17.6) | | | |
| 28,0 (95) | | 7,4 (15.7) | — (13.7) | | |
| 32,0 (105) | | | 5,5 (12.3) | 4,7 (10.4) | |
| 34,0 (115) | | | | 4,6 (9.7) | — (6.4) |
| 38,0 (125) | | | | | 2,9 (6.4) |
| 40,0 (135) | | | | | |
| 44,0 (145) | | | | | |
| 46,0 (150) | | | | | |

| Boom m (ft) | 18,2 (60) | 24,4 (80) | 30,5 (100) | 36,6 (120) |
|-------------------|---------------|---------------|---------------|---------------|
| Radius | | | | |
| 22,0 (75) | | | | |
| 24,0 (80) | | | | |
| 26,0 (85) | | | | |
| 28,0 (95) | | | | |
| 32,0 (105) | 6,0 (13.4) | | | |
| 34,0 (115) | 5,5 (11.7) | 4,8 (10.6) | | |
| 38,0 (125) | 4,7 (10.4) | 4,2 (9.3) | 3,5 (7.9) | |
| 40,0 (135) | | 3,9 (8.2) | 3,3 (7.1) | 2,4 (5.3) |
| 44,0 (145) | | | 2,8 (6.2) | 2,2 (4.9) |
| 46,0 (150) | | | | 2,0 (4.4) |

| Boom m (ft) | 18,2 (60) | 24,4 (80) | 30,5 (100) |
|-------------------|--------------|--------------|---------------|
| Radius | | | |
| 36,0 (120) | — (9.7) | | |
| 38,0 (125) | 4,4 (9.7) | | |
| 40,0 (130) | 4,0 (9.0) | 3,2 (7.1) | |
| 42,0 (140) | 3,6 (7.9) | 3,1 (6.8) | — (4.6) |
| 44,0 (150) | 3,4 (7.1) | 2,9 (6.0) | 2,0 (4.6) |
| 48,0 (160) | 2,9 (—) | 2,4 (5.1) | 1,9 (4.0) |
| 50,0 (170) | | 2,1 (—) | 1,7 (3.3) |
| 52,0 (175) | | | 1,5 (3.1) |
| 54,0 (180) | | | |
| 58,0 (190) | | | |

| Boom m (ft) | 18,2 (60) |
|-------------------|--------------|
| Radius | |
| 36,0 (120) | |
| 38,0 (125) | |
| 40,0 (130) | |
| 42,0 (140) | |
| 44,0 (150) | — (5.1) |
| 48,0 (160) | 2,2 (4.9) |
| 50,0 (170) | 2,0 (4.0) |
| 52,0 (175) | 1,7 (3.7) |
| 54,0 (180) | 1,6 (3.3) |
| 58,0 (190) | — (2.9) |

For complete chart, refer to www.cranelibrary.com.

Meets ANSI B30.5 Requirements - Capacities do not exceed 75% of static tipping load.
 NOTICE: This capacity chart is for reference only and must not be used for lifting purposes.

Clamshell

Boom:

Welded lattice construction using tubular, high-tensile steel chords with pin connections between sections.

Basic boom length: 15,2 m (50 ft)

Max. boom length: 30,5 m (100 ft)

Limit of empty clamshell bucket weight: 2 100 kg (4,600 lb)

Boom component chart

| Boom length m (ft) | Boom arrangement |
|--------------------|--|
| 15,2 (50) | Base-Tip |
| 18,3 (60) | Base-A-Tip |
| 21,3 (70) | Base-A-A-Tip, Base-B-Tip |
| 24,4 (80) | Base-A-B-Tip |
| 27,4 (90) | Base-A-A-B-Tip, Base-B-B-Tip, Base-C-Tip |
| 30,5 (100) | Base-A-B-B-Tip, Base-A-C-Tip |

Base = 7,6 m (25 ft)

Insert: A = 3,05 m (10 ft)

B = 6,10 m (20 ft)

C = 12,2 m (40 ft)

Tip = 7,2 m (25 ft)

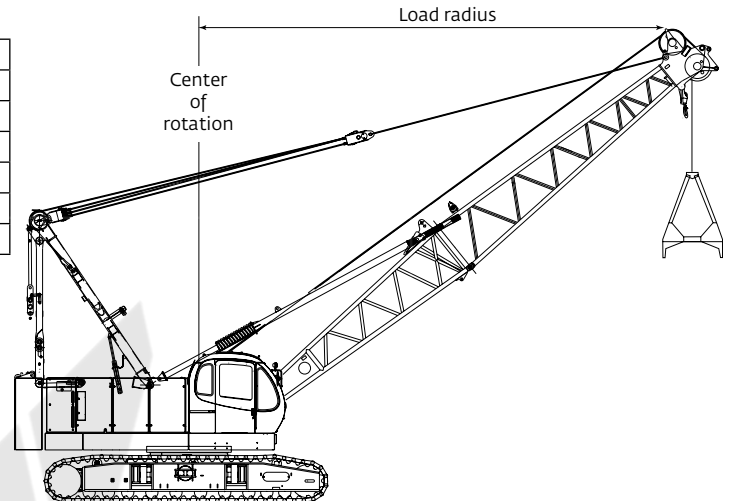

1. Figures represent maximum allowable capacity, and assume level ground and ideal working conditions.
2. Capacities are calculated at 66% of the minimum tipping loads.
3. Capacities are maximum recommended by PCSA Standard #4. Allowances must be made by the user for such unfavorable conditions as a soft or uneven supporting surface, rapid cycle operations, or bucket suction.
4. The combined weight of the bucket and load must not exceed these capacities.
5. Boom length for clamshell operation should not exceed 30,5 m (100 ft).

Clamshell Capacities

10 000 kg (22,050 lb) counterweight
(one upper counterweight, crawlers extended)

kg (lb) x 1 000

| Boom m (ft) | 15,2 (50) | 18,3 (60) | 21,3 (70) | 24,4 (80) | 27,4 (90) | 30,5 (100) |
|-------------|-------------|-------------|------------|------------|------------|------------|
| Radius | | | | | | |
| 7,0 (22) | 10,0 (25.0) | | | | | |
| 8,0 (26) | 10,0 (25.0) | | | | | |
| 9,0 (30) | 10,0 (25.0) | 10,0 (25.0) | | | | |
| 10,0 (34) | 10,0 (25.0) | 9,7 (25.0) | 9,7 (25.0) | | | |
| 14,0 (45) | 10,0 (23.1) | 7,8 (22.9) | 7,8 (22.7) | 7,8 (22.5) | 7,8 (21.6) | |
| 15,0 (50) | | 6,6 (19.8) | 6,6 (19.6) | 6,6 (19.4) | 6,6 (19.2) | 6,6 (18.5) |
| 17,0 (55) | | 5,7 (12.5) | 5,7 (17.2) | 5,7 (17.0) | 5,7 (16.8) | 5,7 (16.5) |
| 18,0 (60) | | | 5,0 (15.2) | 5,0 (15.0) | 5,0 (14.8) | 5,0 (14.6) |
| 21,0 (70) | | | | 4,4 (11.9) | 4,3 (11.7) | 4,2 (11.5) |
| 24,0 (80) | | | | | — (9.5) | — (9.3) |
| 25,0 (85) | | | | | | — (8.4) |
| 27,0 (90) | | | | | | — (7.7) |

Manitowoc Crane Care

Crane Care is Manitowoc's comprehensive service and support program. It includes classroom and on-site training, prompt parts availability, expert field service, technical support and documentation.

That's commitment you won't find anywhere else.

That's Crane Care.

Service training

Manitowoc specialists work with you in our training centers and in the field to make sure you know how to get maximum performance, reliability and life from your cranes.

Manitowoc Cranes Technical Training Centers provide valuable multi-level training, which is available for all models and attachments, in the following format:

- **Intro to Canbus and Canbus 1, 2, 3**
- **Intro to EPIC and EPIC 1, 2, 3**
- **Small Crawler 1**
- **Canbus 1 and 2 assembly, operation and maintenance**
- **EPIC 1 and 2 assembly, operation and maintenance**

Refer to www.manitowoc.com for course descriptions.

Parts availability

Genuine Manitowoc replacement parts are accessible through your distributor 24 hours a day, 7 days a week, 365 days a year.

Service interval kits

200 hour kit

1,000 hour kit

2,000 hour kit

Hydraulic test kit

U.S. standard tools kit

Field service

Factory-trained service experts are always ready to help maintain your crane's peak performance.

For a worldwide listing of dealer locations, please consult our website at: www.manitowoc.com

Technical support

Manitowoc's dealer network and factory personnel are available 24 hours a day, 7 days a week, 365 days a year to answer your technical questions and more, with the help of computerized programs that simplify crane selection, lift planning, and ground-bearing calculations.

For a worldwide listing of dealer locations, please consult our website at: www.manitowoc.com

Technical documentation

Manitowoc has the industry's most extensive documentation; available in major languages and formats that include print, videotape, and DVD/CD.

Additional copies available through your Authorized Manitowoc Distributor.

- Crane operator's manual
- Crane parts manual
- Crane capacity manual
- Crane vendor manual
- Crane service manual
- Luffing jib operator's/parts manual
- Capacity chart manual - attachments

CD rom versions of the operator's and parts manuals are shipped with each crane. Also available are the following CDs:

- Crane Care Owner CD –
- Ground Bearing Pressure Estimator CD
- Crane Selection and Planning Software (CompuCRANE®)
- EPIC® Crane Library CD consisting of capacity charts, range diagrams, wire rope specifications, travel specifications, crane weights, counterweight arrangements, luffing jib raising procedures, operating range diagrams, drum and lagging charts, boom rigging drawings, jib rigging drawings, outline dimensions and wind condition charts.

Available from your Authorized Manitowoc Cranes Distributor, these videos are available in NTSC, PAL, SECAM, and DVD formats.

- Your Capacity Chart Video
- Respect the Limits Video
- Crane Safety Video
- Boom Inspection/Repair Video

Crane Care Package

Manitowoc has assembled all of the available literature, CD's and videos listed above plus several Manitowoc premiums into one complete Crane Care Package.



Manitowoc Cranes

Regional headquarters

Americas

Manitowoc, Wisconsin, USA

Tel: +1 920 684 6621

Fax: +1 920 683 6277

Shady Grove, Pennsylvania, USA

Tel: +1 717 597 8121

Fax: +1 717 597 4062

Europe, Middle East, Africa

Ecully, France

Tel: +33 (0)4 72 18 20 20

Fax: +33 (0)4 72 18 20 00

China

Shanghai, China

Tel: +86 21 6457 0066

Fax: +86 21 6457 4955

Greater Asia-Pacific

Singapore

Tel: +65 6264 1188

Fax: +65 6862 4040

Regional offices

Americas

Brazil

Alphaville

Mexico

Monterrey

Chile

Santiago

Europe, Middle East,

Africa

Czech Republic

Netvorice

France

Baudemont

Cergy

Decines

Germany

Langenfeld

Hungary

Budapest

Italy

Lainate

Netherlands

Breda

Poland

Warsaw

Portugal

Baltar

Russia

Moscow

U.A.E.

Dubai

U.K.

Buckingham

China

Beijing

Chengdu

Guangzhou

Xian

Greater Asia-Pacific

Australia

Adelaide

Brisbane

Melbourne

Sydney

India

Calcutta

Chennai

Delhi

Hyderabad

Pune

Korea

Seoul

Philippines

Makati City

Singapore

Factories

Brazil

Alphaville

China

TaiAn

Zhangjiagang

France

Charlieu

Moulines

Germany

Wilhelmshaven

India

Pune

Italy

Niella Tanaro

Portugal

Baltar

Fânzeres

Slovakia

Saris

USA

Manitowoc

Port Washington

Shady Grove

This document is non-contractual. Constant improvement and engineering progress make it necessary that we reserve the right to make specification, equipment, and price changes without notice. Illustrations shown may include optional equipment and accessories and may not include all standard equipment.