

# Technical Data Hydraulic crawler crane

# HS 873 HD

Litronic®

## Basic machine with undercarriage

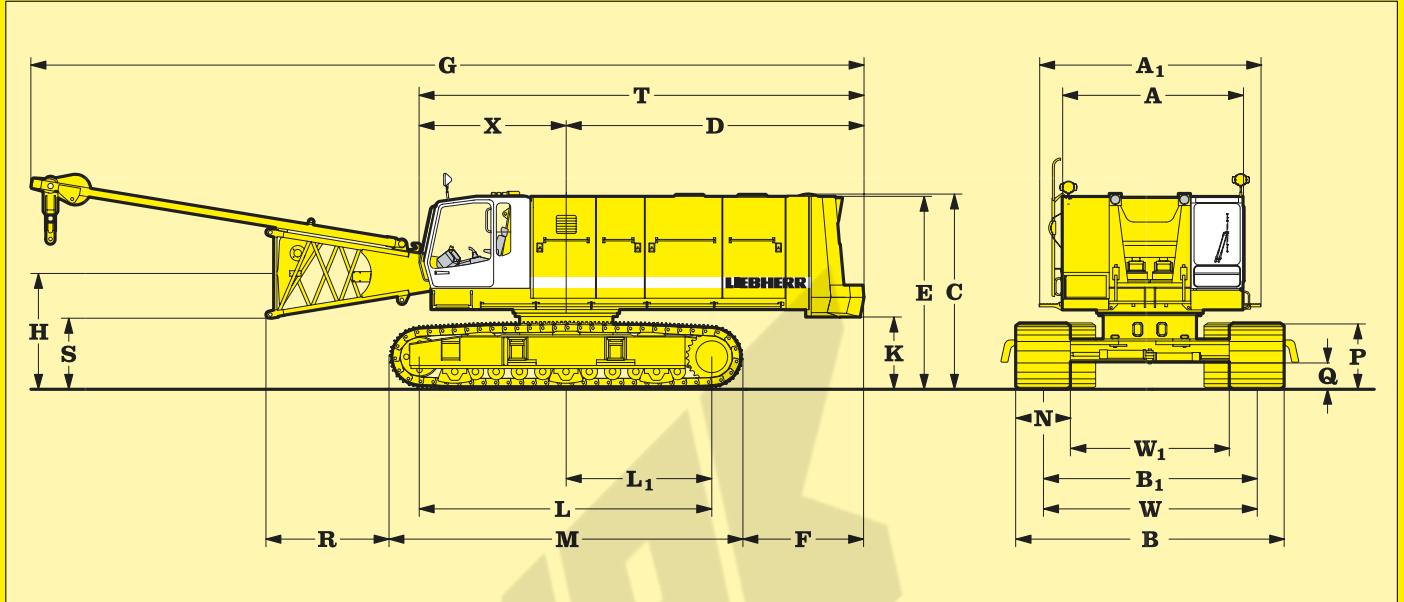

### Dimensions

	mm		mm
A Width of superstructure	3300/3480	X Distance from centre of rotation to end of cab	2685
A <sub>1</sub> Width of superstructure with walk way	4040	N Width of track shoes	700 800 900 1000
C Height of basic machine	3580	W <sub>1</sub> Track width retracted	2900 2900 2900 2900
D Tail reach	5440	W Track width extended	3900 3900 3900 3900
Tail swing radius	5510	B Crawler width extended	4600 4700 4800 4900
E Height over counterweight	3510	B <sub>1</sub> Crawler width retracted	4000 4000 4000 4000
F Distance between rear end of crawler and outside of counterweight	2210		
G Overall length of superstructure with lowered A-frame	15200		
H Ground clearance of boom foot pivot	2130		
K Ground clearance of superstructure	1340		
L Wheel base (centre idler to centre tumbler)	5330		
L <sub>1</sub> Distance from centre of rotation to centre of tumbler	2660		
M Length of crawlers	6460		
P Height of crawlers	1200		
Q Ground clearance of crawler	500		
R Distance from edge of horizontal boom foot to crawler	2250		
S Ground clearance of horizontal boom foot	1300		
T Length of superstructure	8120		

### Operating Weight and Ground Pressure

The operating weight includes the basic unit with B8 crawler tracks, 2 main winches 25 t with speed change gear and 11 m boom, consisting of A-frame, boom foot (4 m), boom head section (6.4 m) boom head (0.6 m) and 19.6 t counterweight + 4.5 t add. counterweight. All systems are ready.

with 700 mm flat track shoes	93.3 t - 1.26 kg/cm <sup>2</sup>
with 800 mm flat track shoes	94.3 t - 1.11 kg/cm <sup>2</sup>
with 900 mm flat track shoes	95.3 t - 1.00 kg/cm <sup>2</sup>
with 1000 mm flat track shoes	96.4 t - 0.91 kg/cm <sup>2</sup>
with 700 mm 3-web shoes	91.5 t - 1.23 kg/cm <sup>2</sup>
with 800 mm 3-web shoes	92.3 t - 1.09 kg/cm <sup>2</sup>
with 900 mm 3-web shoes	93.1 t - 0.97 kg/cm <sup>2</sup>
with 1000 mm 3-web shoes	93.9 t - 0.88 kg/cm <sup>2</sup>

# LEIBHER

The Better Machine

## Basic machine

with HD undercarriage, V-8-Liebherr diesel engine, 2 x 25 t winches with change gear box, without counterweight, boom foot and A-frame

3-web shoes	mm	700	800	900	1000
Width	mm	4000	4000	4000	4000
Weight	t	61.2	62.0	62.8	63.6
L Length	mm	8270	8270	8270	8240
H Height	mm	3580	3580	3580	3580

## Counterweight

		Basic	Additional
Width	mm	720	690
Weight	kg	19600	4500
L Length	mm	3200	3200
H Height	mm	2200	585

## A-frame

		short	long
Width	mm	1100	1410
Weight	kg	1895	2175
L Length	mm	5730	6930
H Height	mm	1440	1440

## Boom foot

		Basic
Width	mm	1460
Weight	kg	1955
L Length	mm	4200
H Height	mm	1550

## Tubular boom extension

		3 m	6 m	9 m
Width	mm	1460	1460	1460
Weight*	kg	725	1120	1500
L Length	mm	3170	6170	9170
H Height	mm	1450	1450	1450

## Boom head section

Width	mm	1460
Weight*	kg	1150
L Length	mm	6530
H Height	mm	1450

## Boom head

		A	B
Width	mm	780	1060
Weight	kg	1500	1775
L Length	mm	2665	2820
H Height	mm	1800	1170

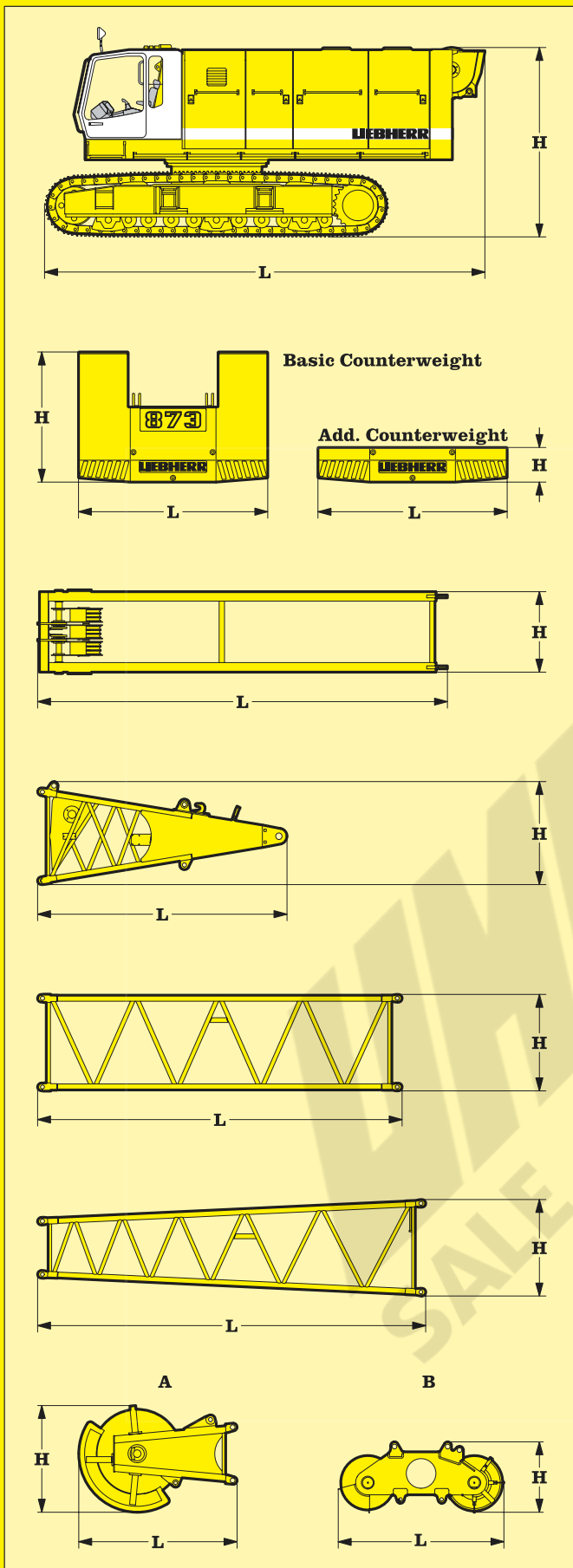

\*) including stay ropes

# Transport dimensions and weights



## Engine

Water cooled, V-8-cylinder Liebherr diesel engine, turbo charged with intercooler, model D 9408 TI-E, power rating according to ISO 9249, 340 kW (462 hp) at 1900 rpm.

Option:

Water cooled, V-12-cylinder Mercedes Benz diesel engine, turbo charged with intercooler, type OM 444 LA, power rating according to DIN ISO 3046 IFN, 448 kW (609 hp) at 1900 rpm.

The automatic limiting load control adapts perfectly the power of the main users to the present engine speed.

The temperature and engine speed controlled cooling system saves energy and reduces the noise emission.

Fuel Tank: 920 l capacity with continuous level indicator and reserve warning.



## Hydraulic System

The main pumps are operated by a distributor gearbox. Axial piston displacement pumps work in closed and open circuits supplying oil only when needed (flow control on demand). To minimize peak pressure an automatically working pressure cut off is integrated. This spares pumps and saves energy.

Winch 1 and 2: Axial piston displacement pumps (swash plate design) with 500 l/min. each.

Crawlers: Axial piston displacement pumps (swash plate design) with 2 x 396 l/min.

Swing gear: Axial piston displacement pump (swash plate design) with 283 l/min.

Boom hoist: Axial piston displacement pump (swash plate design) with 200 l/min.

Max. working pressure: 350 bar.

Hydraulic oil tank capacity: 1100 l

The hydraulic oil is cleaned through electro-nically controlled pressure and return filters.

Possible contamination is signaled in the cabin. The use of synthetic environmentally friendly oils is possible.

Ready made hydraulic retrofit kits are available to customize requirements e. g. powering casing oscillators, auger drills etc.



## Winches

Winch options:

Line pull (nom. load)	160 kN	200 kN	250 kN
Rope diameter :	26 mm	30 mm	34 mm
Drum diameter :	550 mm	630 mm	750 mm
Rope speed m/min	0-106	0-85	0-69
With change gear box			0-154
Rope capacity 1st layer	46.5 m	46.5 m	45.9 m

The winches are outstanding in their compact design and easy assembly.

Propulsion is via a planetary gearbox in oil bath. Load support by the hydraulic system; additional safety factor provided by a spring loaded, multi-disc holding brake.

Clutch and braking functions on the freefall system are provided by a compact designed, low wear and maintenance free multi-disc brake. The dragline and hoist winches use pressure controlled, variable flow hydraulic motors. This system features sensors that automatically adjust oil flow to provide max. winch speed depending on load.

Working with 2 rope clamshell, the oil motors distribute the load to both winches providing speed compensation, even when working in different rope layers.

Option:

Crane winch 160 kN (16 t) - without clutch, but with multi-disc holding brake.



## Noise emission

Special sound proofing results in a very low noise pressure level of 78 dB (A) at 16 m radius.



## Equipment

Lattice boom of tubular construction up to 50 m, universal boom head with interchangeable rope pulleys. Modular designed equipment for operation as crane, dragline or clamshell.

For dragline operation, a rotating fairlead is fitted into the boom foot, which minimizes rope angle to drum, which results in lower rope wear.



## Swing Drive

Consists of single row ballbearing with external teeth for lower tooth flank pressure, fixed axial piston hydraulic motor, spring loaded and hydraulically released multi-disc holding brake, planetary gearbox and pinion.

Free swing with hydraulic moment control reduces wear to a minimum, because rotation moment is sustained through the hydraulic system by the diesel engine. A multi-disc holding brake acts automatically at zero swing motion. Swing speed from 0 - 3.7 rpm continuously variable.



## Crawler

The track width of the undercarriage is changed hydraulically.

Propulsion through axial piston motor, hydraulically released spring loaded multi-disc brake, maintenance free crawler tracks, hydraulic chain tensioning device.

Flat or 3 - web track shoes. Drive speed 0 - 1.6 km/h.

Option:

2 speed hydraulic motor for higher travel speed.



## Control

The control system - developed and manufactured by Liebherr - is designed to withstand extreme temperature and the many heavy-duty construction tasks for which this crane has been designed. Complete machine operating data are displayed on a high resolution monitor screen.

To ensure clarity of the information on display, different levels of data are shown in enlarged lettering and symbols. Control and monitoring of the sensors are also handled by this high technology system. Error indications are automatically displayed on the monitor in English.

The crane is equipped with proportional control for all movements, which can be carried out simultaneously.

A special "Interlock" control system is also optionally available. It is designed for power lifting of the dragline bucket without using the grab winch brake.

An additional option is also the so-called "Redundant" control system, which allows restricted operation of the machine in the event of a failure on the electronic base control or its sensors.

On request, Liebherr also offers special custom designed control systems for free fall winches.

The crane is operated with 2 multi-directional joysticks, right for winch I and boom hoist drive, left for winch II and slewing gear. Crawler control is actuated with the two central foot pedals. Additionally, hand levers can be attached to the pedals.

Options:

- Both main winches with double-T levers
- Special demolition control system
- MDE: Machine data recording
- PDE: Process data recording



## Boom hoist drive

Twin drum with internally located planetary gearbox, axial piston hydraulic motor and hydraulically released spring loaded multi-disc brake.

Max. line pull 2x 70 kN. Rope diameter: 20 mm

Max. line speed: 23 m/min.

Two speed boom hoist option

# Technical description

## 19.6 t counterweight + 4.5 t add. counterweight

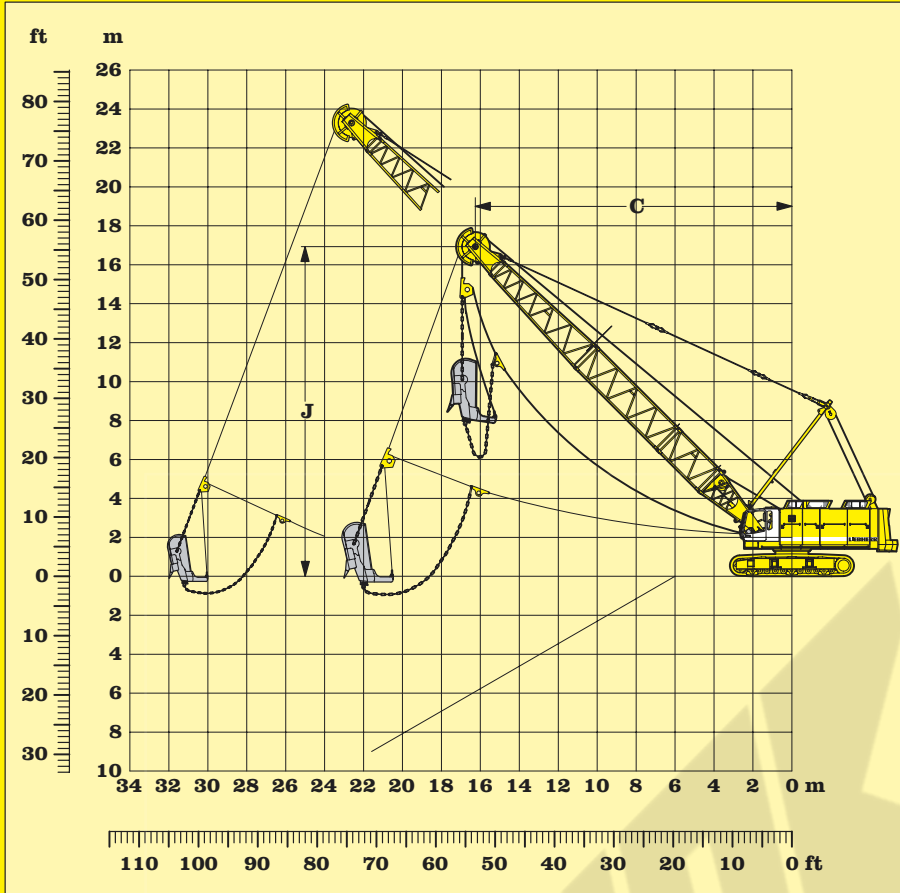

### Scope of delivery:

- Basic machine with corresponding track shoes
- Add. counterweight 4.5 t
- Second swing drive with free swing
- A-frame
- Boom foot 4 m
- Boom extension 3 m tubular steel
- Boom extension 6 m tubular steel
- Boom extension 9 m tubular steel
- Boom head section 6.4 m
- Boom head with interchangeable pulleys
- Stay ropes according to boom length
- Main winches according to specification
- Drag rope should be 2 mm below nominal diameter
- Corresponding fair lead
- Corresponding ropes optional
- Dragline bucket optional

Capacities in metric tons for boom lengths from 15 m to 30 m:

Counterweight 24.1 t

$\alpha$	15 m			18 m			21 m			24 m			27 m			30 m		
	C m	J m	t	C m	J m	t	C m	J m	t	C m	J m	t	C m	J m	t	C m	J m	t
45	12.6	12.7	20.4	14.7	14.8	16.3	16.9	16.9	13.1	19.0	19.0	11.2	21.1	21.2	9.5	23.2	23.3	8.1
40	13.5	11.7	18.7	15.8	13.6	14.6	18.1	15.6	12.0	20.4	17.6	10.2	22.7	19.4	8.6	25.0	21.3	7.2
35	14.3	10.7	17.3	16.8	12.4	13.3	19.2	14.1	11.2	21.7	15.8	9.4	24.1	17.5	7.8	26.6	19.3	6.5
30	15.0	9.6	16.0	17.6	11.1	12.4	20.2	12.6	10.2	22.8	14.1	8.5	25.4	15.6	7.0	28.0	17.1	5.8
25	15.6	8.4	15.0	18.3	9.7	11.8	21.0	10.9	9.2	23.8	12.2	7.6	26.5	13.5	6.3	29.2	14.7	5.2

Max. capacities in metric tons do not exceed 75 % of tipping load

Optimal boom configuration for boom lengths between 11 m to 50 m:

	Length	Amount of boom extensions														
		1	1	1	1	1	1	1	1	1	1	1	1	1	1	1
Boom foot	4.0 m	1	1	1	1	1	1	1	1	1	1	1	1	1	1	1
Boom extension	3.0 m		1			1			1			1			1	
Boom extension	6.0 m			1			1			1			1			1
Boom extension	9.0 m				1	1	1	1	2	2	2	3	3	3	4	4
Boom head extension	6.4 m	1	1	1	1	1	1	1	1	1	1	1	1	1	1	1
Boom head	0.6 m	1	1	1	1	1	1	1	1	1	1	1	1	1	1	1
Boom length in (m)		11 m	14 m	17 m	20 m	23 m	26 m	29 m	32 m	35 m	38 m	41 m	44 m	47 m	50 m	

# Dragline equipment

## 19.6 t counterweight + 4.5 t add. counterweight

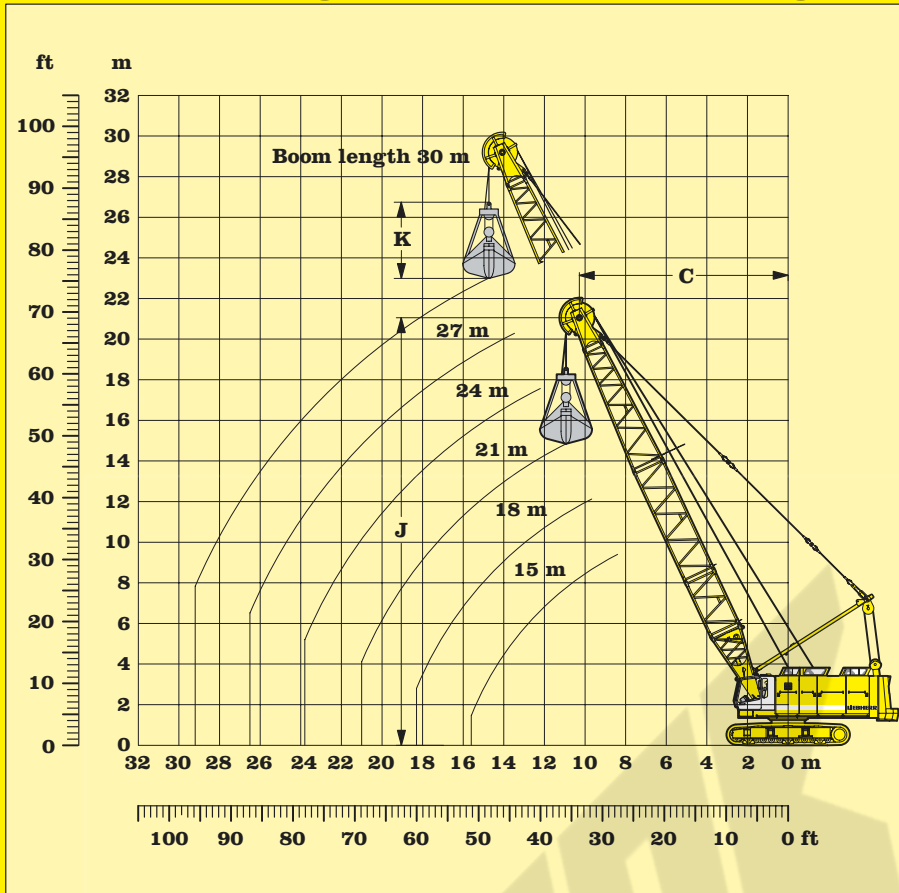

### Scope of delivery:

- Basic machine with corresponding track shoes
- Add. counterweight 4.5 t
- A-frame
- Boom foot 4 m
- Boom extension 3 m tubular steel
- Boom extension 6 m tubular steel
- Boom extension 9 m tubular steel
- Boom head section 6.4 m
- Boom head with interchangeable pulleys
- Stay ropes according to boom length
- Main winches according to specification
- Tagline winch
- Corresponding ropes optional
- Clamshell optional
- Hoist limit switch
- Load moment limitation
- 4-rope clamshell on request

### Working diagram

- C = Radius / dumping radius
- J = Height of boom head sheave centre above ground level
- K = Length of clamshell (depending on type and capacity of bucket)

Capacities in metric tons for boom lengths from 15 m to 30 m:													Counterweight 24.1 t					
α	15 m			18 m			21 m			24 m			27 m			30 m		
	C	J	t	C	J	t	C	J	t	C	J	t	C	J	t	C	J	t
65	8.4	15.6	28.0	9.6	18.4	23.5	10.9	21.1	20.3	12.2	23.8	17.6	13.4	26.5	15.3	14.7	29.2	13.4
60	9.5	15.0	26.5	11.0	17.6	21.4	12.5	20.2	18.2	14.0	22.8	15.4	15.5	25.4	13.2	17.0	28.0	11.4
55	10.6	14.3	23.0	12.4	16.8	18.7	14.1	19.3	15.5	15.8	21.7	13.1	17.5	24.2	11.2	19.2	26.6	9.6
50	11.7	13.5	20.3	13.6	15.8	16.4	15.5	18.1	13.6	17.4	20.4	11.4	19.4	22.7	9.6	21.3	25.0	8.2
45	12.6	12.7	18.2	14.7	14.8	14.7	16.9	16.9	12.1	19.0	19.0	10.1	21.1	21.2	8.5	23.2	23.3	7.2
40	13.5	11.7	16.6	15.8	13.6	13.3	18.1	15.6	10.9	20.4	17.5	9.1	22.7	19.4	7.6	25.0	21.3	6.4
35	14.3	10.7	15.3	16.8	12.4	12.3	19.2	14.1	10.1	21.7	15.8	8.3	24.1	17.5	6.9	26.6	19.3	5.7
30	15.0	9.6	14.4	17.6	11.1	11.5	20.2	12.6	9.4	22.8	14.1	7.7	25.4	15.6	6.4	28.0	17.1	5.3
25	15.6	8.4	13.5	18.3	9.7	10.8	21.0	10.9	8.8	23.8	12.2	7.2	26.5	13.5	5.9	29.2	14.7	4.9

Max. capacities in metric tons do not exceed 66.7 % of tipping load.

Load diagram restricted by safety factors of standard ropes:

Winches	160 kN	200 kN	250 kN
Rope diameter	26 mm	30 mm	34 mm
Calc. breaking load	613 kN	820 kN	1051 kN
1-rope clamshell	11.1 t	14.8 t	19.0 t
2-rope clamshell	16.8 t	22.5 t	28.9 t

# Clamshell equipment

## 19.6 t counterweight + 4.5 t add. counterweight

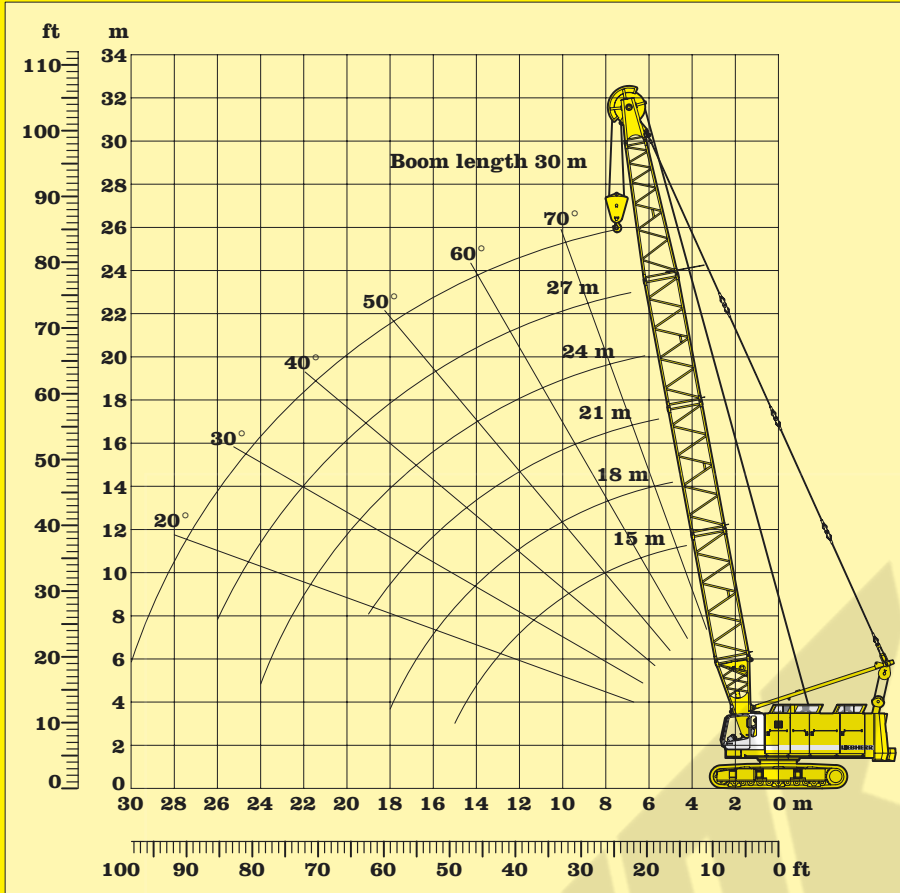

### Scope of delivery:

- Basic machine with corresponding track shoes
- Add. counterweight 4.5 t
- A-frame
- Boom foot 4 m
- Boom extension 3 m tubular steel
- Boom extension 6 m tubular steel
- Boom extension 9 m tubular steel
- Boom head section 6.4 m
- Boom head with interchangeable pulleys
- Stay ropes according to boom length
- Main winches according to specification
- Corresponding ropes optional
- Hoist limit switch
- Load moment limitation
- Corresponding hook block optional

### Remarks:

1. The lifting capacities are valid for wide track.
2. The lifting capacities stated do not exceed 75% of tipping load
3. The lifting capacities are indicated in metric tons with unlimited swing (360 degrees)
4. The weight of the lifting device must be deducted to arrive at the lifting capacity.
5. Working radii are measured from centre of swing.
6. Crane standing on firm, horizontal ground.
7. Indicated values on load chart are affected by off-lead operation, wind speeds, load under slew and stop/go movements.

Capacities in metric tons for boom lengths from 15 m to 30 m:

Counterweight 24.1 t

Boom length	15 m	18 m	21 m	24 m	27 m	30 m
Radius in (m)	t	t	t	t	t	t
5	40.4					
5.5	39.3	35.4				
6	38.3	34.6	31.3			
6.5	37.4	33.7	30.6	28.0		
7	36.4	33.0	30.0	27.4	23.7	
7.5	35.5	32.2	29.3	26.8	23.2	21.4
8	34.7	31.5	28.7	24.7	22.8	21.0
9	32.4	30.0	27.5	23.8	21.9	20.2
10	28.0	27.9	26.3	22.8	21.1	19.5
11	24.6	24.5	23.8	22.0	20.3	18.8
12	21.9	21.8	21.6	21.1	19.5	18.1
13	21.7	19.6	19.4	19.2	18.8	17.4
14	19.7	17.7	17.5	17.3	17.1	16.8
15	17.8	16.1	16.0	15.8	15.6	15.4
16	16.2	14.8	14.6	14.4	14.2	14.0
17		13.6	13.4	13.3	13.1	12.9
18		12.6	12.4	12.2	12.0	11.8
19			11.5	11.3	11.1	10.9
20				10.5	10.3	10.1
22				9.2	9.0	8.8
24				8.0	7.9	7.7
26					6.9	6.7
28						5.9
30						5.2

# Lifting capacity with dragline boom head

## 19.6 t counterweight

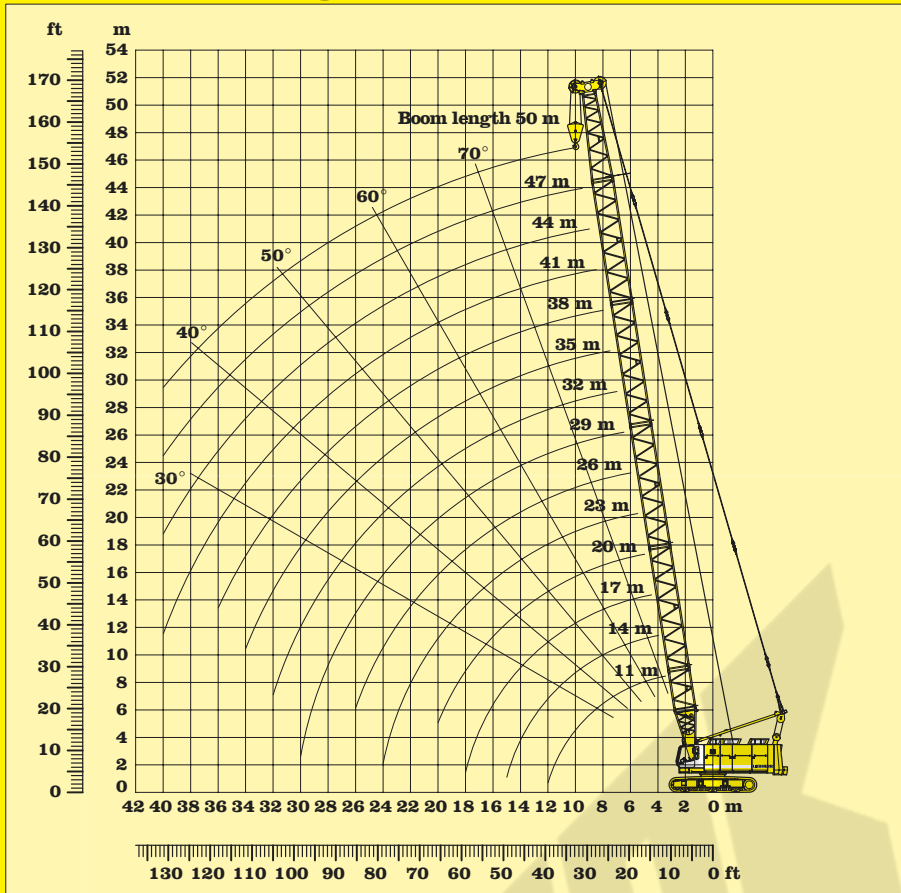

### Scope of delivery:

- Basic machine with corresponding track shoes
- A-frame
- Boom foot 4 m
- Boom extension 3 m tubular steel
- Boom extension 6 m tubular steel
- Boom extension 9 m tubular steel
- Boom head section 6.4 m
- Boom head with interchangeable pulleys
- Stay ropes according to boom length
- Main winches according to specification
- Corresponding ropes optional
- Hoist limit switch
- Load moment limitation
- Corresponding hook block optional

### Remarks:

1. The lifting capacities are valid for wide track.
2. The lifting capacities stated do not exceed 75% of tipping load
3. The lifting capacities are indicated in metric tons with unlimited swing (360 degrees)
4. The weight of the lifting device must be deducted to arrive at the lifting capacity.
5. Working radii are measured from centre of swing.
6. Crane standing on firm, horizontal ground.
7. Indicated values on load chart are affected by off-lead operation, wind speeds, load under slew and stop/go movements.

Capacities in metric tons for boom lengths from 11 m to 50 m:											Counterweight 19.6 t			
Boom length	11 m	14 m	17 m	20 m	23 m	26 m	29 m	32 m	35 m	38 m	41 m	44 m	47 m	50 m
Radius in (m)	t	t	t	t	t	t	t	t	t	t	t	t	t	t
4	90.0													
4.5	80.0	71.3												
5	71.8	68.6	64.2											
5.5	61.1	64.1	61.0	58.2										
6	53.1	53.0	53.0	52.9	52.7									
6.5	46.8	46.8	46.7	46.6	46.5	46.4								
7	41.9	41.9	41.8	41.6	41.5	41.4	41.2	40.5						
7.5	37.8	37.8	37.7	37.6	37.4	37.3	37.1	37.0	36.8					
8	34.4	34.4	34.3	34.2	34.0	33.9	33.7	33.6	33.4	33.2				
9	29.1	29.1	29.0	28.9	28.7	28.6	28.4	28.2	28.0	27.8	27.7	20.6		
10	25.1	25.1	25.0	24.9	24.7	24.6	24.4	24.2	24.0	23.8	23.6	19.0	15.1	12.2
11	22.0	22.0	21.9	21.8	21.6	21.5	21.3	21.1	20.9	20.7	20.5	17.5	13.9	11.2
12	19.4	19.5	19.4	19.3	19.2	19.0	18.8	18.6	18.4	18.2	18.0	16.2	12.8	10.4
13		17.5	17.4	17.3	17.1	16.9	16.8	16.6	16.4	16.2	16.0	15.0	12.0	9.6
14		15.8	15.7	15.6	15.4	15.3	15.1	14.9	14.7	14.5	14.3	13.9	11.2	8.9
15		14.3	14.3	14.2	14.0	13.8	13.6	13.4	13.2	13.0	12.8	12.6	10.4	8.2
16			13.0	12.9	12.8	12.6	12.4	12.2	12.0	11.8	11.6	11.4	9.7	7.6
17			11.9	11.9	11.7	11.5	11.3	11.1	10.9	10.7	10.5	10.3	9.1	7.1
18			11.0	10.9	10.8	10.6	10.4	10.2	10.0	9.8	9.6	9.4	8.5	6.6
19				10.1	9.9	9.8	9.6	9.4	9.2	9.0	8.8	8.6	8.0	6.1
20				9.3	9.2	9.0	8.9	8.7	8.5	8.2	8.0	7.8	7.5	5.7
22					7.9	7.8	7.6	7.4	7.2	7.0	6.8	6.6	6.3	4.9
24					6.9	6.7	6.6	6.4	6.2	6.0	5.7	5.5	5.2	4.2
26						5.9	5.7	5.5	5.3	5.1	4.8	4.6	4.3	3.6
28							5.0	4.8	4.5	4.3	4.0	3.8	3.5	3.0
30							4.2	4.1	3.8	3.6	3.4	3.1	2.9	2.5
32								3.5	3.3	3.0	2.8	2.5	2.3	2.0
34									2.7	2.5	2.3	2.0	1.8	1.5
36										2.1	1.8	1.6	1.3	1.1
38											1.4	1.2	0.9	0.7

# Lifting capacity with multi sheave HD boom head

# 19.6 t counterweight + 4.5 t add. counterweight

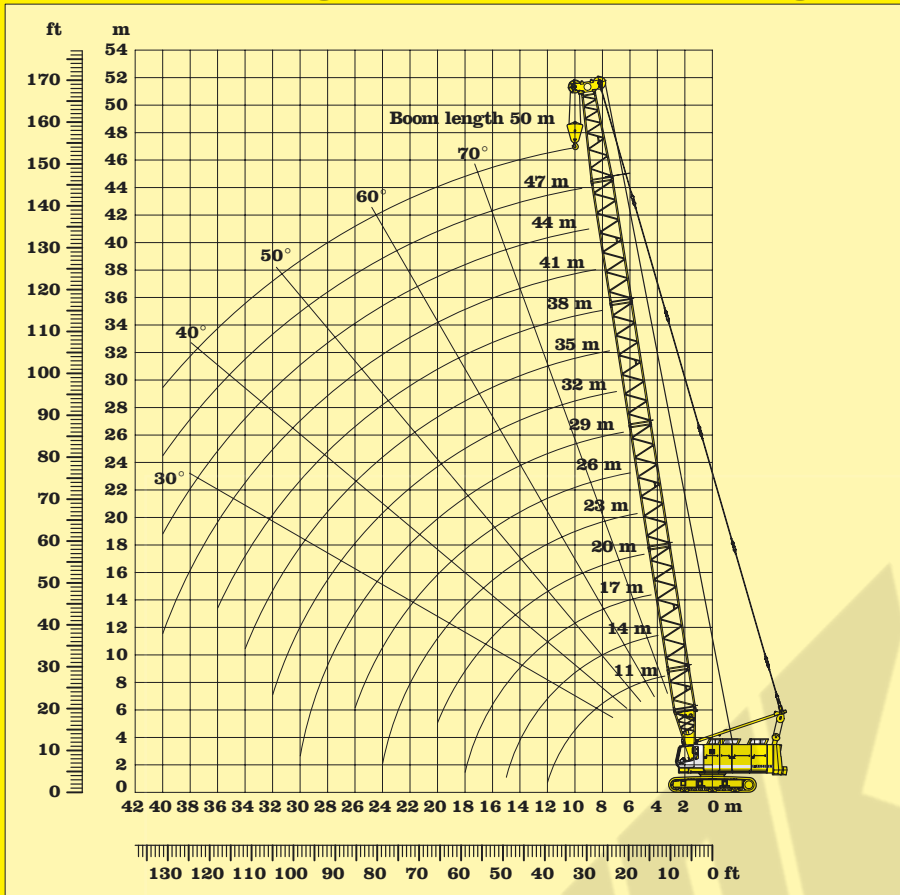

## Scope of delivery:

- Basic machine with corresponding track shoes
- Add. counterweight 4.5 t
- A-frame
- Boom foot 4 m
- Boom extension 3 m tubular steel
- Boom extension 6 m tubular steel
- Boom extension 9 m tubular steel
- Boom head section 6.4 m
- Boom head with interchangeable pulleys
- Stay ropes according to boom length
- Main winches according to specification
- Corresponding ropes optional
- Hoist limit switch
- Load moment limitation
- Corresponding hook block optional

## Remarks:

1. The lifting capacities are valid for wide track.
2. The lifting capacities stated do not exceed 75% of tipping load
3. The lifting capacities are indicated in metric tons with unlimited swing (360 degrees)
4. The weight of the lifting device must be deducted to arrive at the lifting capacity.
5. Working radii are measured from centre of swing.
6. Crane standing on firm, horizontal ground.
7. Indicated values on load chart are affected by off-lead operation, wind speeds, load under slew and stop/go movements.

Capacities in metric tons for boom lengths from 11 m to 50 m:											Counterweight 24.1 t			
Boom length	11 m	14 m	17 m	20 m	23 m	26 m	29 m	32 m	35 m	38 m	41 m	44 m	47 m	50 m
Radius in (m)	t	t	t	t	t	t	t	t	t	t	t	t	t	t
4	100.0													
4.5	86.0	71.3												
5	73.6	68.2	64.2											
5.5	68.1	66.2	62.0	58.2										
6	59.2	59.2	59.1	56.3	52.9									
6.5	52.3	52.3	52.2	52.1	51.3	46.9								
7	46.8	46.8	46.7	46.6	46.4	45.6	43.0	40.5						
7.5	42.3	42.3	42.2	42.0	41.9	41.7	41.6	39.4	37.1					
8	38.5	38.5	38.4	38.3	38.1	38.0	37.8	37.6	36.2	34.1				
9	32.6	32.6	32.5	32.4	32.2	32.1	31.9	31.7	31.5	31.3	28.4	20.6		
10	28.2	28.2	28.1	27.9	27.8	27.6	27.4	27.3	27.1	26.9	23.6	19.0	15.1	12.2
11	24.7	24.7	24.6	24.5	24.3	24.2	24.0	23.8	23.6	23.4	21.9	17.5	13.9	11.2
12	21.9	22.0	21.9	21.8	21.6	21.4	21.2	21.1	20.9	20.7	20.4	16.2	12.8	10.4
13		19.7	19.6	19.5	19.3	19.2	19.0	18.8	18.6	18.4	18.2	15.0	12.0	9.6
14		17.8	17.8	17.6	17.5	17.3	17.1	16.9	16.7	16.5	16.3	13.9	11.2	8.9
15		16.1	16.2	16.0	15.9	15.7	15.5	15.3	15.1	14.9	14.7	13.0	10.4	8.2
16			14.8	14.7	14.5	14.3	14.2	14.0	13.8	13.6	13.3	12.2	9.7	7.6
17			13.6	13.5	13.3	13.2	13.0	12.8	12.6	12.4	12.2	11.5	9.1	7.1
18			12.5	12.4	12.3	12.1	11.9	11.7	11.5	11.3	11.1	10.8	8.5	6.6
19				11.5	11.4	11.2	11.0	10.8	10.6	10.4	10.2	10.0	8.0	6.1
20				10.7	10.6	10.4	10.2	10.0	9.8	9.6	9.4	9.2	7.5	5.7
22					9.2	9.0	8.8	8.6	8.4	8.2	8.0	7.8	6.6	4.9
24					8.0	7.9	7.7	7.5	7.3	7.1	6.9	6.7	5.8	4.2
26						6.9	6.7	6.5	6.3	6.1	5.9	5.6	5.1	3.6
28							5.9	5.7	5.5	5.3	5.0	4.8	4.5	3.0
30							5.1	5.0	4.8	4.5	4.3	4.0	3.8	2.5
32								4.3	4.1	3.9	3.7	3.4	3.1	2.1
34									3.6	3.3	3.1	2.8	2.6	1.7
36										2.8	2.6	2.3	2.1	1.3
38											2.1	1.9	1.6	1.0
40												1.7	1.5	0.7

LIEBHERR-WERK NENZING GMBH,

P.O. Box 10, A-6710 Nenzing / Austria / Europe

Telephone (0043) 5525 - 606 - 473

Telefax (0043) 5525 - 606 - 499

Email: info@lwn.liebherr.com

Presented by: