

LIEBHERR 281 HC

TOWER CRANE

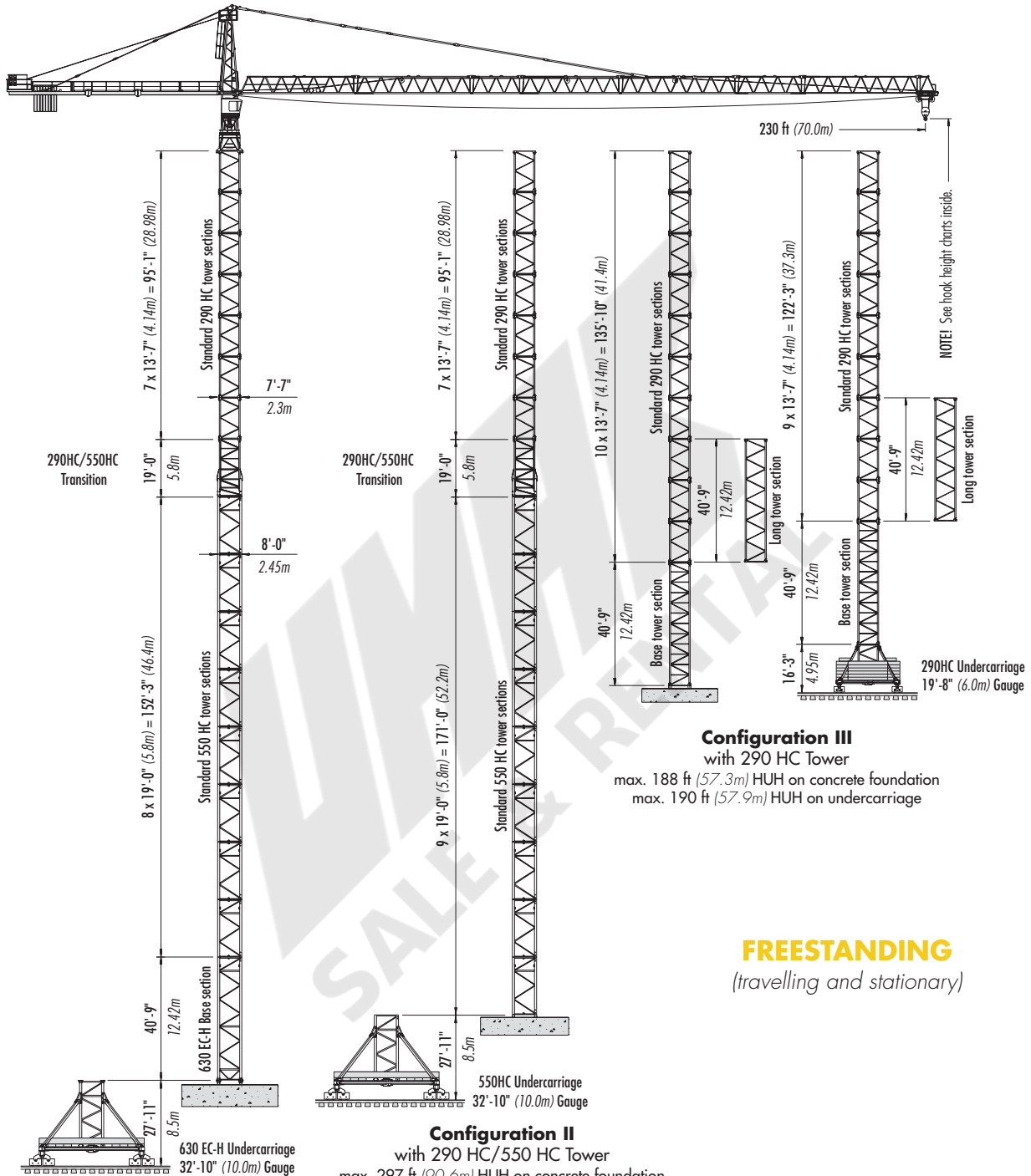

Configuration III

with 290 HC Tower
 max. 188 ft (57.3m) HUH on concrete foundation
 max. 190 ft (57.9m) HUH on undercarriage

FREESTANDING
 (travelling and stationary)

Configuration I

with 290 HC/550 HC/630 EC-H Tower
 max. 319 ft (97.1m) HUH on concrete foundation
 max. 346 ft (105.3m) HUH on undercarriage

Configuration II

with 290 HC/550 HC Tower
 max. 297 ft (90.6m) HUH on concrete foundation
 max. 324 ft (98.7m) HUH on undercarriage



Morrow Equipment

Configurations

LIEBHERR 281 HC

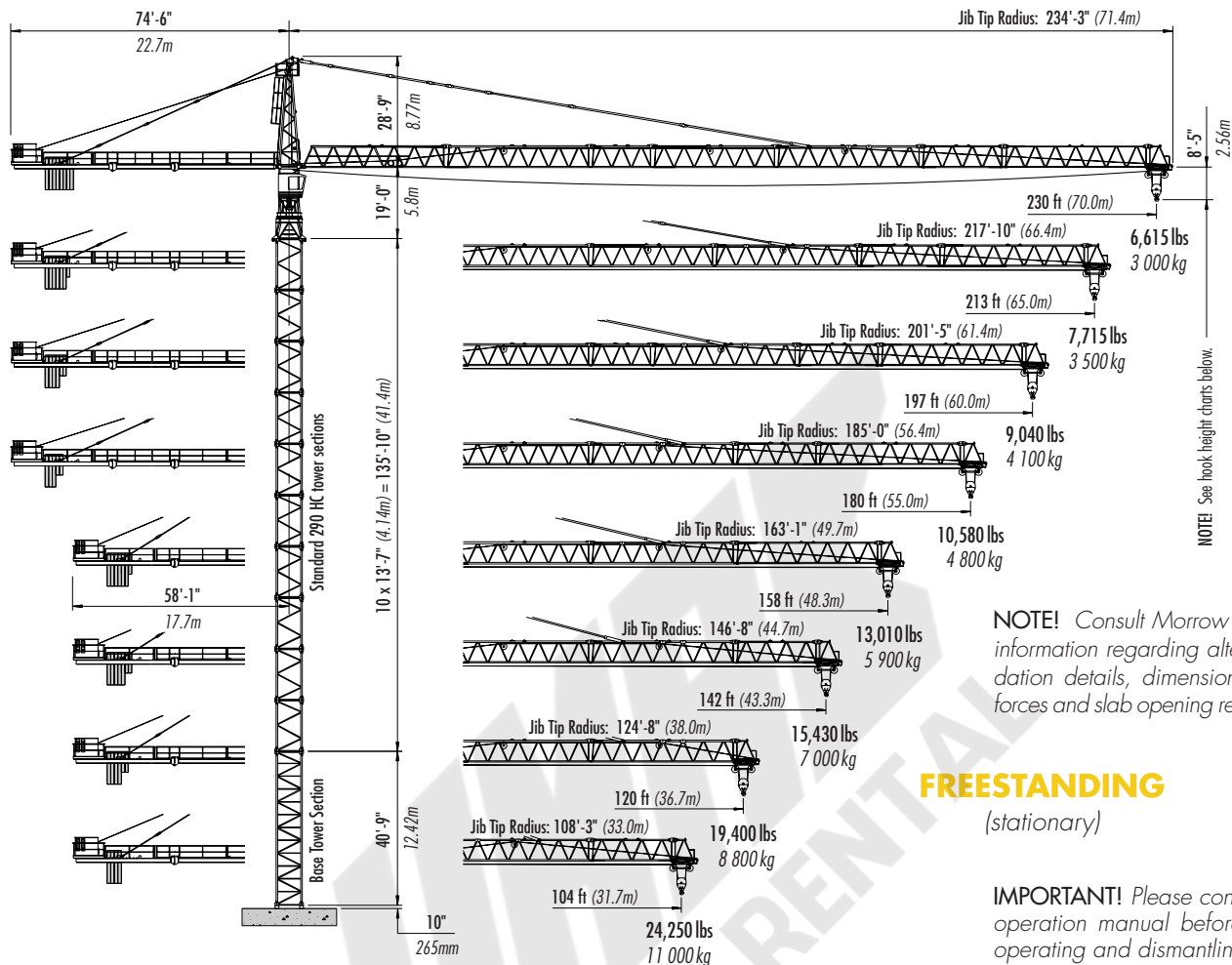

FREESTANDING (stationary)

IMPORTANT! Please consult crane's operation manual before erecting, operating and dismantling crane.

HOOK HEIGHTS

No. of Tower Elements	Tower Configuration I	Hook Height Concrete Foundation		Hook Height 10m Undercarriage		No. of Tower Elements	Tower Configuration II	Hook Height Concrete Foundation		Hook Height 10m Undercarriage		No. of Tower Sections	Tower Configuration III	Hook Height Concrete Foundation		Hook Height 6m Undercarriage	
		ft	m	ft	m			ft	m	ft	m			ft	m	ft	m
1	630 EC-H BS	52.3	15.9	79.3	24.2	1	550 HC STS	31.0	9.4	57.5	17.5	0	290 HC BTS	52.2	15.9	67.6	20.6
2	550 HC STS	71.3	21.7	98.3	30.0	2	550 HC STS	50.0	15.2	76.6	23.3	1	290 HC STS	65.8	20.1	81.2	24.8
3	550 HC STS	90.4	27.5	117.3	35.8	3	550 HC STS	69.0	21.0	95.6	29.1	2	290 HC STS	79.4	24.2	94.8	28.9
4	550 HC STS	109.4	33.3	136.4	41.6	4	550 HC STS	88.1	26.8	114.6	34.9	3	290 HC STS	93.0	28.3	108.4	33.0
5	550 HC STS	128.4	39.1	155.4	47.4	5	550 HC STS	107.1	32.6	133.7	40.7	4	290 HC STS	106.6	32.5	121.9	37.2
6	550 HC STS	147.4	44.9	174.4	53.2	6	550 HC STS	126.1	38.4	152.7	46.5	5	290 HC STS	120.2	36.6	135.5	41.3
7	550 HC STS	166.5	50.7	193.4	59.0	7	550 HC STS	145.1	44.2	171.7	52.3	6	290 HC STS	133.7	40.8	149.1	45.5
8	550 HC STS	185.5	56.5	212.5	64.8	8	550 HC STS	164.2	50.0	190.7	58.1	7	290 HC STS	147.3	44.9	162.7	49.6
9	550 HC STS	204.5	62.3	231.5	70.6	9	550 HC STS	183.2	55.8	209.8	63.9	8	290 HC STS	160.9	49.0	176.3	53.7
10	Transition	223.6	68.1	250.5	76.4	10	Transition	202.2	61.6	228.7	69.7	9	290 HC STS	174.5	53.2	189.9 ²	57.9 ²
11	290 HC STS	237.1	72.2	264.1	80.5	11	290 HC STS	215.8	65.8	242.4	73.9	10	290 HC STS ³	188.1 ³	57.3 ³		
12	290 HC STS	250.7	76.4	277.7	84.6	12	290 HC STS	229.4	69.9	256.0	78.0						
13	290 HC STS	264.3	80.6	291.3	88.8	13	290 HC STS	243.0	74.1	269.6	82.2						
14	290 HC STS	277.9	84.7	304.9	92.9	14	290 HC STS	256.6	78.2	283.1	86.3						
15	290 HC STS	291.5	88.8	318.4	97.1	15	290 HC STS	270.1	82.3	296.7	90.4						
16	290 HC STS	305.1	93.0	332.0	101.2	16	290 HC STS	283.7	86.5	310.3	94.6						
17	290 HC STS ¹	318.6	97.1	345.6	105.3	17	290 HC STS ¹	297.3	90.6	323.9	98.7						

¹ Remove top climbing unit from crane prior to operating crane at maximum hook height.

² Lower top climbing unit to base of crane prior to operating crane at maximum hook height [190 ft (57.9m)].

³ Lower top climbing unit to base of crane prior to operating crane at maximum hook height [188 ft (57.3m)].

Configurations

LIEBHERR 281 HC

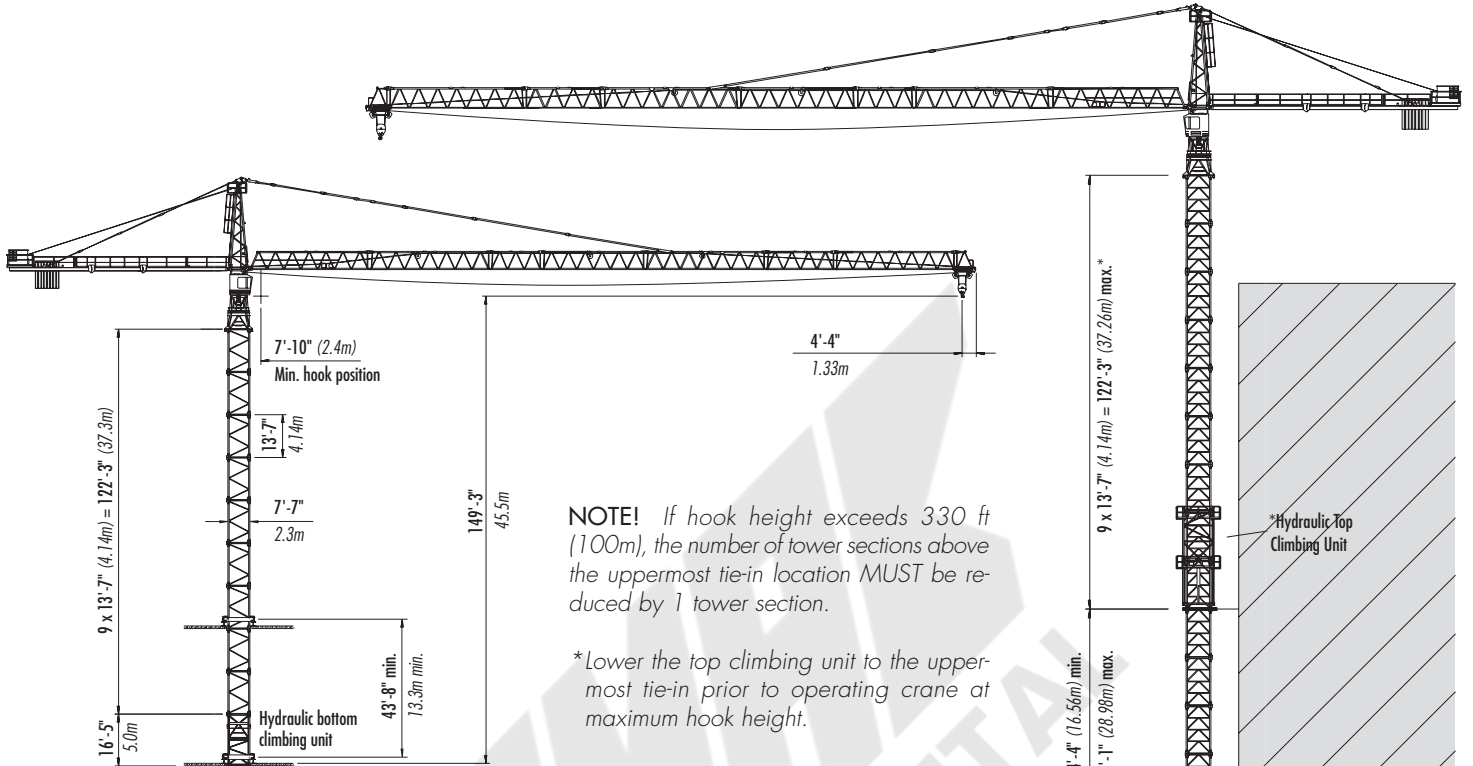

NOTE! If hook height exceeds 330 ft (100m), the number of tower sections above the uppermost tie-in location **MUST** be reduced by 1 tower section.

*Lower the top climbing unit to the uppermost tie-in prior to operating crane at maximum hook height.

BOTTOM CLIMBING with 290 HC Tower Sections (inside structure)

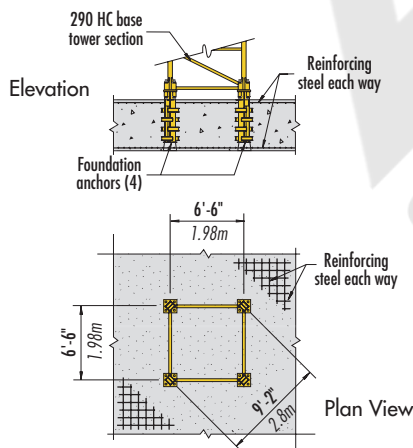

FOUNDATION DETAILS with 290 HC Base Tower (on concrete slab)

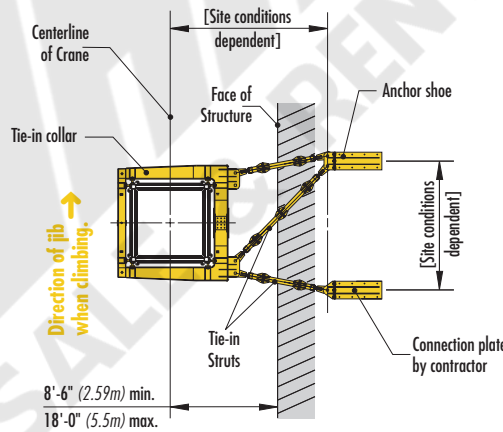

TIE-IN ASSEMBLY (Plan View)

NOTE! The tie-in assembly shown is an example of a typical installation. Please note, however, that factors determining the installation of tie-in assemblies may vary due to project specific criteria. Contact Morrow for information regarding dimensions, reaction forces, tie-in locations and slab opening requirements.

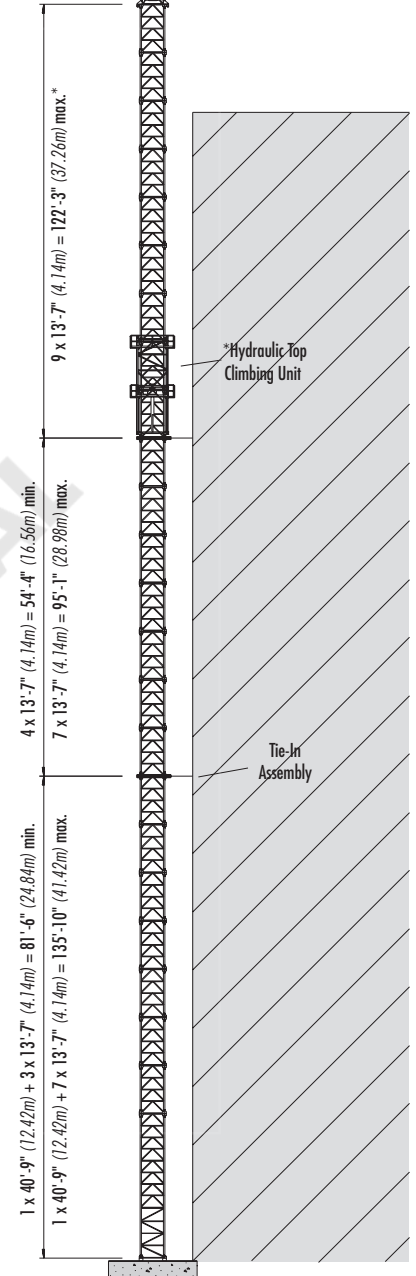

TOP CLIMBING with 290 HC Tower Sections (tied to structure)

Radius and Capacities

LIEBHERR Tower Crane Model 281 HC

2-Part Line

Hook Radius	2-Part Line Max Capacity – Radius	ft m	60 18.3	70 21.3	80 24.4	90 27.4	104 31.7	110 33.5	120 36.7	130 39.6	142 43.3	150 45.7	158 48.3	170 51.8	180 55.0	190 58.0	197 60.0	213 65.0	230 70.0
230 ft 70.0m	22,045 lbs – 86 ft 10 000 kg – 26.2m	lbs kg	22,045 10 000	22,045 10 000	22,045 10 000	20,955 9 505	17,747 8 050	16,643 7 549	14,958 6 785	13,672 6 201	12,280 5 570	11,495 5 214	10,737 4 870	9,833 4 460	9,105 4 130	8,534 3 871	8,135 3 690	7,319 3 320	6,615 3 000
213 ft 65.0m	22,045 lbs – 89 ft 10 000 kg – 27.3m	lbs kg	22,045 10 000	22,045 10 000	22,045 10 000	21,922 9 943	18,563 8 420	17,424 7 903	15,675 7 110	14,319 6 495	12,875 5 840	12,067 5 474	11,266 5 110	10,340 4 690	9,590 4 350	8,975 4 071	8,576 3 890	7,715 3 500	
197 ft 60.0m	26,455 lbs – 79 ft 12 000 kg – 24.1m	lbs kg	26,455 12 000	26,455 12 000	26,132 11 853	22,897 10 386	19,445 8 820	18,253 8 280	16,424 7 450	15,033 6 819	13,514 6 130	12,688 5 755	11,861 5 380	10,882 4 936	10,097 4 580	9,469 4 295	9,040 4 100		
180 ft 55.0m	26,455 lbs – 82 ft 12 000 kg – 25.0m	lbs kg	26,455 12 000	26,455 12 000	26,455 12 000	23,944 10 861	20,305 9 210	19,061 8 646	17,174 7 790	15,712 7 127	14,154 6 420	13,274 6 021	12,412 5 630	11,402 5 172	10,580 4 800				
158 ft 48.3m	26,455 lbs – 85 ft 12 000 kg – 26.0m	lbs kg	26,455 12 000	26,455 12 000	26,455 12 000	24,987 11 334	21,219 9 625	19,932 9 041	17,957 8 145	16,435 7 455	14,815 6 720	13,904 6 307	13,010 5 900						
142 ft 43.3m	26,455 lbs – 88 ft 12 000 kg – 26.9m	lbs kg	26,455 12 000	26,455 12 000	26,455 12 000	25,979 11 784	22,068 10 010	20,737 9 406	18,695 8 480	17,124 7 767	15,430 7 000								
120 ft 36.7m	26,455 lbs – 91 ft 12 000 kg – 27.8m	lbs kg	26,455 12 000	26,455 12 000	26,455 12 000	26,455 12 000	22,906 10 390	21,522 9 762	19,400 8 800										
104 ft 31.7m	26,455 lbs – 96 ft 12 000 kg – 29.3m	lbs kg	26,455 12 000	26,455 12 000	26,455 12 000	26,455 12 000	24,250 11 000												

Capacity

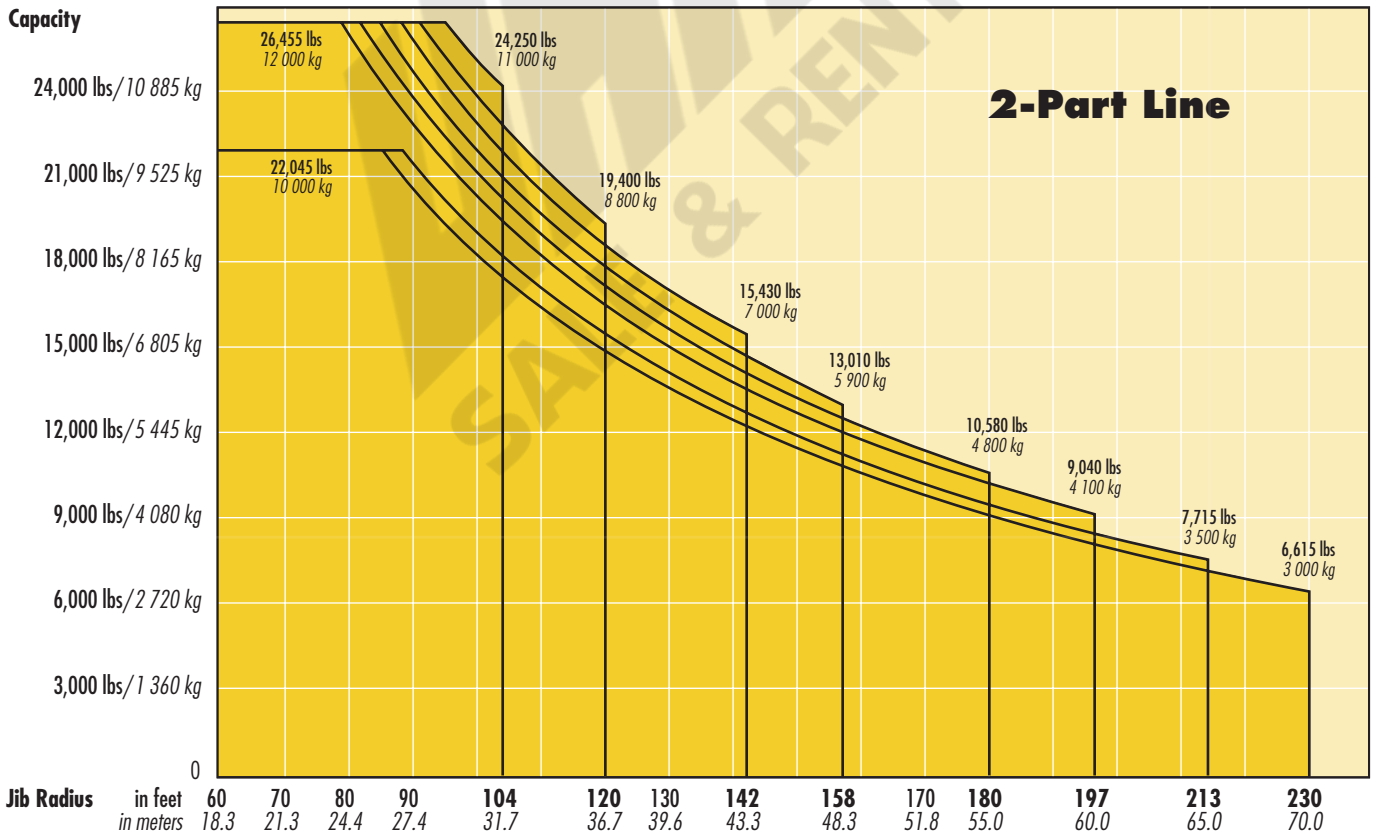

SPECIFICATIONS

LIEBHERR Tower Crane Model 281 HC

Hoist Speed and Capacity

Hoist Unit	WiW281RX056	2-Part Line				
		Gear	Capacity	Line Speed	Capacity	Line Speed
108 hp (80 kW) AC hoist unit 3-speed gearbox Electromagnetic gear shifting Eddy current brake	2L-142	1	up to 26,455 lbs	@ 108 fpm	up to 12 000 kg	@ 33 m/min
		2	up to 9,920 lbs	@ 292 fpm	up to 4 500 kg	@ 89 m/min
		3	up to 3,970 lbs	@ 587 fpm	up to 1 800 kg	@ 179 m/min

NOTE! Capacities and line speeds indicated will vary depending on the amount of hoist rope installed. This crane model may be equipped with a hoist unit other than that specified in the data above. To verify, check the serial number of the crane and refer to the Liebherr 281 HC Operation Manual for additional information.

Motor Information

Drive Unit	Horsepower	Kilowatts	Speed	
Trolley	7.4 hp	5.5 kW	26 - 52 - 164 - 312 fpm	8 - 16 - 50 - 95 m/min
Swing (fluid coupling)	2 x 6.7 hp	2 x 5.0 kW	0.7 rpm	
Traveling (fluid coupling)	2 x 10 hp	2 x 7.5 kW	98 fpm	30.0 m/min











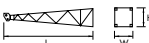
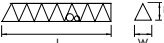

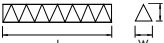
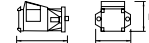
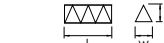

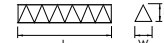
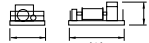
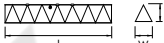

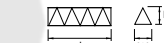

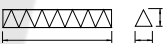

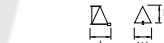
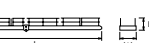
Power Requirements

480 V — 3-phase — 60 Hz — 225 Amperes

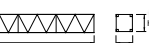
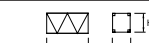
Specifications subject to change without prior notice. For additional information, contact Morrow Equipment.

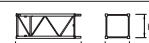
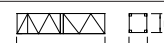
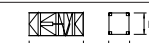
Component List

LIEBHERR 281 HC

Description	Dimensions L x W x H	Weight	Description	Dimensions L x W x H	Weight
Tower Top 	29'-3" x 5'-5" x 6'-1" 8.9m x 1.65m x 1.85m	6,000 lbs 2 720 kg	Jib Section ① #611 	39'-0" x 6'-1" x 6'-4" 11.89m x 1.85m x 1.92m	6,950 lbs 3 150 kg
Slewing Assembly (Complete) ¹ 	20'-7" x 9'-0" x 8'-9" 6.27m x 2.74m x 2.67m	20,300 lbs 9 210 kg	Jib Section ② #621 	39'-5" x 5'-4" x 6'-2" 12.02m x 1.63m x 1.87m	4,870 lbs 2 210 kg
Slewing Assembly Upper Part ² 	14'-8" x 9'-0" x 8'-9" 4.47m x 2.74m x 2.67m	11,925 lbs 5 410 kg	Jib Section ③ #633 	17'-7" x 5'-4" x 6'-2" 5.36m x 1.63m x 1.87m	2,040 lbs 925 kg
Slewing Assembly Lower Part ³ 	6'-6" x 9'-0" x 7'-9" 1.98m x 2.74m x 2.36m	8,375 lbs 3 800 kg	Jib Section ④ #634 	34'-0" x 5'-4" x 6'-1" 10.36m x 1.63m x 1.86m	4,110 lbs 1 865 kg
Hoist Unit with Frame ⁴ 108 hp (80 kW) 	8'-4" x 15'-0" x 5'-8" 2.54m x 4.57m x 1.73m	12,790 lbs 5 800 kg	Jib Section ⑤ #622 	39'-5" x 5'-5" x 6'-1" 12.02m x 1.65m x 1.86m	4,565 lbs 2 070 kg
Counterjib Section #1 (Inner) 	27'-9" x 5'-10" x 5'-7" 8.46m x 1.77m x 1.7m	4,760 lbs 2 160 kg	Jib Section ⑥ #632 	23'-1" x 5'-4" x 6'-1" 7.03m x 1.63m x 1.86m	2,240 lbs 1 015 kg
Counterjib Section #2 (Intermediate) 	17'-2" x 5'-10" x 5'-7" 5.23m x 1.77m x 1.7m	4,000 lbs 1 815 kg	Jib Section ⑦ #631 	39'-5" x 5'-4" x 6'-1" 12.02m x 1.63m x 1.86m	2,850 lbs 1 290 kg
Counterjib Section #3 (Outer) 	27'-7" x 8'-0" x 5'-7" 8.41m x 2.44m x 1.7m	6,200 lbs 2 800 kg	Jib Section ⑧ #641 	7'-4" x 6'-1" x 6'-10" 2.24m x 1.85m x 2.08m	730 lbs 330 kg
Counterjib A ⁵ 	54'-8" x 8'-0" x 5'-7" 16.67m x 2.44m x 1.7m	12,500 lbs 5 670 kg	Jib Assembly ⁷ 230-ft (70.0m) ①②③④⑤⑥⑦⑧	231'-0" x 6'-1" x 6'-10" 70.4m x 1.85m x 2.08m	32,405 lbs 14 700 kg
Counterjib B ⁶ 	71'-1" x 8'-0" x 5'-7" 21.67m x 2.44m x 1.7m	16,500 lbs 7 485 kg	Jib Assembly ⁷ 213-ft (65.0m) ①②④⑤⑥⑦⑧	214'-7" x 6'-1" x 6'-10" 65.4m x 1.85m x 2.08m	29,980 lbs 13 600 kg
Counterweight Block A 	4'-4" x 11" x 8'-1" 1.32m x 0.28 x 2.46m	4,960 lbs 2 250 kg	Jib Assembly ⁷ 197-ft (60.0m) ①②③⑤⑥⑦⑧	198'-2" x 6'-1" x 6'-10" 60.4m x 1.85m x 2.08m	27,560 lbs 12 500 kg
Counterweight Block B 	4'-4" x 11" x 5'-4" 1.32m x 0.28 x 1.63m	3,195 lbs 1 450 kg	Jib Assembly ⁷ 180-ft (55.0m) ①②⑤⑥⑦⑧	181'-9" x 6'-1" x 6'-10" 55.4m x 1.85m x 2.08m	24,690 lbs 11 200 kg
Base Tower Section 290 HC 	40'-9" x 7'-7" x 7'-7" 12.42m x 2.3m x 2.3m	17,505 lbs 7 940 kg	Jib Assembly ⁷ 158-ft (48.3m) ①②⑤⑦⑧	159'-11" x 6'-1" x 6'-10" 48.7m x 1.85m x 2.08m	22,485 lbs 10 200 kg
Long Tower Section 290 HC 	40'-9" x 7'-7" x 7'-7" 12.42m x 2.3m x 2.3m	12,170 lbs 5 520 kg	Jib Assembly ⁷ 142-ft (43.3m) ①②⑤⑥⑧	143'-6" x 6'-1" x 6'-10" 43.8m x 1.85m x 2.08m	21,605 lbs 9 800 kg
Standard Tower Section 290 HC 	13'-7" x 7'-7" x 7'-7" 4.14m x 2.3m x 2.3m	5,025 lbs 2 280 kg	Jib Assembly ⁷ 120-ft (36.7m) ①②⑤⑧	121'-8" x 6'-1" x 6'-10" 37.1m x 1.85m x 2.08m	19,400 lbs 8 800 kg
Transition Section 550 HC/290 HC 	20'-7" x 8'-5" x 8'-5" 6.28m x 2.57m x 2.57m	13,050 lbs 5 920 kg	Jib Assembly ⁷ 104-ft (31.7m) ①⑤⑥⑧	105'-3" x 6'-1" x 6'-10" 32.1m x 1.85m x 2.08m	16,315 lbs 7 400 kg
Standard Tower Section 550 HC 	20'-7" x 8'-0" x 8'-0" 6.28m x 2.44m x 2.44m	13,340 lbs 6 050 kg	Top Climbing Unit w/hydraulics 	27'-6" x 9'-2" x 8'-10" 8.38m x 2.79m x 2.69m	16,535 lbs 7 500 kg
Bottom Climbing Unit w/hydraulics 	16'-5" x 7'-6" x 7'-10" 5.0m x 2.28m x 2.4m	13,200 lbs 5 990 kg	Hook Block 	2'-0" x 1'-7" x 3'-9" 0.62m x 0.48m x 1.14m	1,345 lbs 610 kg
Tie-in Collar 290 HC 	10'-10" x 1'-3" x 10'-1" 3.29m x 0.39m x 3.08m	4,850 lbs 2 200 kg	Trolley 	6'-2" x 6'-0" x 3'-11" 1.89m x 1.83m x 1.2m	835 lbs 380 kg

NOTE: Weights and dimensions are approximate. Scale components before lifting.

¹ Includes operator's cab, swing motors, slewing ring, ring support and 4 climbing shoes. Two climbing shoes are detachable; deduct 100 lbs (45 kg) each. Dimensions above are without detachable climbing shoes.

² Includes operator's cab and swing motors.

³ Includes slewing ring, ring support and 4 climbing shoes. Two climbing shoes are detachable; deduct 100 lbs (45 kg) each. Dimensions above are without detachable climbing shoes.

⁴ Includes 108 hp (80 kW) hoist unit, electrical panel and handrails. Does not include wire rope.

⁵ Includes counterjib sections #1, #3, pendant bars and handrails. Counterjib A is required for jibs 158 ft (48.3m) and shorter.

⁶ Includes counterjib sections #1, #2, #3, pendant bars and handrails. Counterjib B is required for jibs 180 ft (55.0m) and longer.

⁷ Includes jib sections, pendant bars, pendant bar connecting pins and plates, trolley drive unit, trolley wire rope and trolley.



Morrow Equipment
C O M P A N Y, L. L. C.

3218 Pringle Road SE • P O Box 3306 • Salem, Oregon 97302-0306 USA
Tel. 503.585.5721 • Fax. 503.363.1172 • www.morrowequipment.com

The American home of
LIEBHERR

Atlanta, GA • Charlotte, NC • Chicago, IL • Denver, CO • Honolulu, HI • Houston, TX • Los Angeles, CA • Las Vegas, NV
Millwood, NY • St. Louis, MO • San Francisco, CA • Seattle, WA • Miami, FL • Tampa, FL • Washington, DC
Sydney, Australia • Wellington, New Zealand • Vancouver, BC, Canada • Toronto, ON, Canada • México DF, México