



GROVE[®]
worldwide

TMS800B

Carrier-Mounted Hydraulic Crane Specifications



Carrier specifications

Frame	High strength alloy steel all welded box-type construction with integral outrigger housings and front/rear lifting, towing and tie down lugs.
Outrigger System	Hydraulic single stage double box telescopic beam and outriggers with integral holding valves. Inverted jack cylinders (4). Standard 5th vertical jack mounted to the front frame section to permit 360° lifting capabilities. All steel fabricated quick release type outrigger floats 30.5" (775mm) diameter Maximum outrigger pad load 103,434 lbs. (46,918 kgs).
Outrigger Controls	Located in superstructure cab and both sides of carrier. Push button controls requiring two-handed operation. Crane level indicator (sight bubble) adjacent to controls.
Engine	Cummins NTA855C six cylinder turbo-charged after cooled diesel 855 cu. in. (14 L) 310 bhp (231 kw) (gross) @ 2100 RPM. Maximum torque 1005 ft. lbs. (139 kg/m) @ 1400 RPM.
Fuel Tank Capacity	(1) 100 gallons (379 L)
Electrical System	Two 12-volt - maintenance free batteries, 24 volt starting.
Drive	8 x 4
Steering	Front axle steering, worm and lever type with hydraulic assist.
Transmission	Roadranger gearbox with 9 speeds forward and 2 reverse, with 2 speed auxiliary transmission.
Axles	Axles 1 & 2, steering, tubular steel, 102 in. (2591mm) track. Axles 3 & 4, single reduction drive, 100 in. (2540mm) track.
Suspension	Front axles (1 & 2) spring mounted tandem. Rear axles (3 & 4) solid mount tandem with equalizing beam and solid steel saddles.
Tires	Front: 445/65R22.5-20PR radial, highway tread singles. Rear: 12.00R20-18PR highway tread tube type duals.
Optional Tires	Rear: 365/80R20-20PR highway tread tube type duals.
Brakes	Full air on all wheels. Air dryer provided to preclude moisture accumulation. Spring set emergency brake on both rear axles with emergency release.
Lights	Full lighting including head, tail, braking, reversing, directional and hazard warning lights

Cab	One man design, all steel fabricated with acoustical lining and tinted safety glass throughout. Deluxe fabric covered fully adjustable seat. Complete driving controls and engine instrumentation including tachometer, speedometer, voltmeter, water temp. oil pressure, fuel level, air pressure gauge with A/V warning. Other standard items include hot water heater/defroster, electric windshield washer-wiper, fire extinguisher, seat belt and door and window locks.
------------	---

Maximum Speed	49.7 MPH (80 kph)
	BASIC STANDARD MACHINE
Gross Vehicle Weight & Axle Loads	Front Tandem: 41,922 lbs. (19,016 kgs) Rear Tandem: 59,168 lbs. (26,839 kgs) G.V.W.: 101,090 lbs. (45,855 kgs)
Miscellaneous Standard Equipment	Dual rear view mirrors, hookblock tiedown sling, electronic back-up alarm, light package, engine low oil pressure/high water temperature audio visual warning, carrier mounted outrigger controls, Jacobs engine brake, tire inflation kit.
Optional Equipment	Immersion engine block heater, trailing boom prep., trailer air and electrical, air conditioning.

*Denotes optional equipment.

Superstructure specifications

Boom	40 ft. - 125 ft. (12.1m - 38.1m) four section Trapezoidal boom, sequenced-synchronizing. Telescopic sections slide on adjustable and replaceable Nylatron pads. Maximum Tip Height: 133 ft. (40.5m).
Telescopic Swingaway	32 ft. - 44 ft. - 56 ft. (9.8m - 13.4m - 17.1m) telescopic lattice swingaway extension with offset links, offsettable at 2°, 15° or 30°. Stows alongside base boom when not in use. Maximum Tip Height: 188 ft. (57.3m)
Boom Nose	Six steel sheaves mounted on heavy duty tapered roller bearings with removable pin-type rope guards. *Optional removable single sheave auxiliary boom nose with removable pin type rope guard.
Boom Elevation	Two double acting hydraulic cylinders with integral holding valve provide elevation from -3.75° to 81.5°.
Load Moment & Anti-Two Block System	Standard load moment and anti-two block system with audio-visual warning and control lever lockout. These systems provide electronic display of boom angle, length, radius, tip height, relative load moment, maximum permissible load, load indication and warning of impending two-block conditions.
Cab	Full vision, all steel fabricated with acoustical lining and tinted safety glass throughout. Dash panel incorporates gauges for all engine functions. Other standard features include: hinged skylight, sliding left side door and sliding right side window, electric windshield washer-wiper, circulating air fan, heater, swing horn, fire extinguisher, seat belt. *Optional: air conditioning.
Swing	Ball bearing swing circle with 360° continuous rotation. Grove planetary "glide-swing" with foot actuated disc brake, spring applied hydraulically released park brake and 360° position positive turntable lock. Combination controls provided for hand or foot operation. Swing speed 1.4 RPM.
Counterweight	Fixed position pinned to turntable. Power installation and removal system. Weight varies depending on hoist configuration.

HYDRAULIC SYSTEM

Pumps	Two tandem main gear pumps driven by carrier engine through PTO with manual disconnect. Combined capacity 188 GPM (678 LPM).
Valves	Precision four way double acting control valves, 4 individual valve banks permit simultaneous control of multiple crane functions.
Filter	Return line type, full flow with by-pass protection and filter by-pass indicator, replaceable cartridge, 7/17/22 micron filtration rating.
Reservoir	197 gallons (746 L) with spin-on breather filter, external sight gauge, clean out access, strap mounted to frame.
Oil Cooler	Full flow, fin and tube, oil to air.

HOIST SPECIFICATIONS

Series parallel circuitry and two motors provide both high line pull and speed ranges. Power up and down, equal speed, planetary reduction with integral automatic brake and electronic hoist drum rotation indicator.

Main and *Auxiliary Hoist Grove HO30B-26

Make/Model		High Range	Low Range
Maximum single line speed	Bottom layer	458 FPM (140m/min)	229 FPM (70m/min)
	Intermediate layer	534 FPM (163m/min)	267 FPM (81m/min)
	Top layer	608 FPM (185m/min)	304 FPM (92m/min)
Maximum single line pull	Bottom layer	8,161 lbs. (3701 kg)	16,322 lbs. (7402 kg)
	Intermediate layer	7,028 lbs. (3187 kg)	14,056 lbs. (6375 kg)
	Top layer	6,172 lbs. (2799 kg)	12,344 lbs. (5598 kg)
Maximum permissible line pull		12,920 lbs. (5860 kg)	
w/5:1 strength factor		3/4 in. (19mm) 18 x 19 class	
Maximum rope stowage		832 ft. (253m) 3/4 in. (19mm)	
		Note: 650 ft. (198m) length of 3/4 in. (19mm) wire rope supplied with basic standard unit.	

*Denotes optional equipment

Dimensions

TMS800B

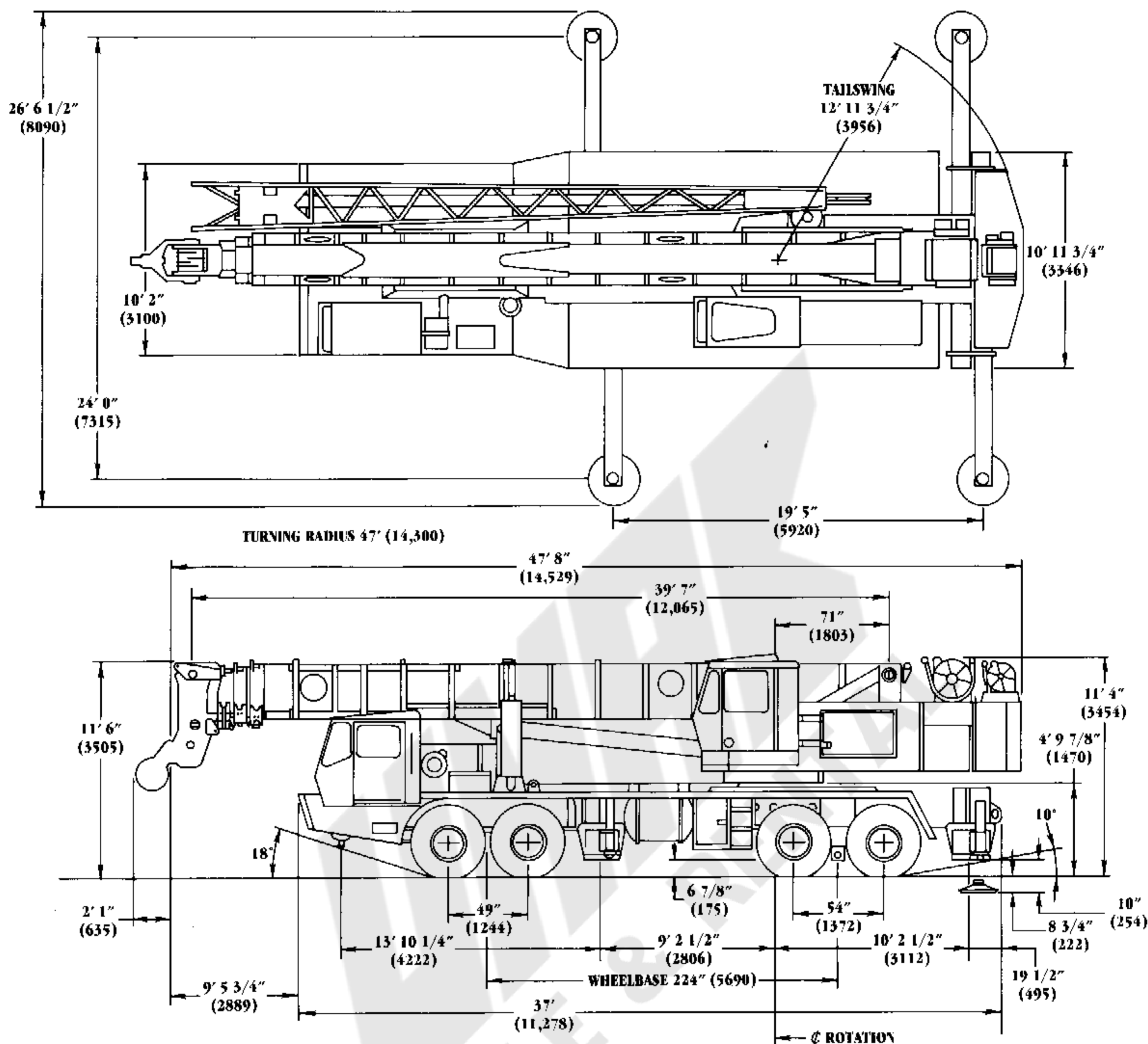

GROVE
worldwide

Grove Worldwide - World Headquarters
1565 Buchanan Trail East
Shady Grove, Pennsylvania 17256
Phone: (717) 597-8121 Telex: 1842308 Fax: (717) 597-4062

Grove North America
P.O. Box 21, Shady Grove, Pennsylvania 17256
Western Hemisphere, Asia/Pacific
Phone: (717) 597-8121 Telex: 1842308 Fax: (717) 597-4062

Grove Europe*
Sunderland, England SR4 6TT
Europe, Africa, Middle East, Near East
Phone: (091) 565-6281 Telex: 53484 CRANES G Fax: (091) 564-0442

*Grove Europe Limited, Registered in England, Number 1815128. Registered office, Crown Works, Pallion, Sunderland, Tyne & Wear, England SR4 6TT.

Constant improvement and engineering progress make it necessary that we reserve the right to make specification, equipment, and price changes without notice. Illustrations shown may include optional equipment and accessories and may not include all standard equipment.

Distributed By: