

GROVE[®] TMS 185

**HYDRAULIC
CRANE with
TRAPEZOIDAL[†]
BOOM**

**18 TON
CAPACITY**

[†]Patented Grove feature



**HYDRAULIC
CRANES**





SUPERSTRUCTURE SPECIFICATIONS

BOOM – 32 ft. - 106 ft. total length (9.8m-32.3m); 3 section trapezoidal main boom consisting of base plus 2 full power sections (including a cable synchronized fly) to 80 ft. (24.4m) plus a 26 ft. (7.9m) "swing-away" lattice extension (2° offset) to 106 ft. (32.3m). Mid section is powered by one 7 in. (178mm) bore diameter cylinder with integral holding valve. Fly section (629mm) tread diameter extension sheaves and retracted by a separate 5/8 in. (16mm) cable. Boom telescope sections are supported on graphite impregnated nylonon wear pads. Side adjustable wear pads prevent metal to metal contact of inner boom sections and permit ease of boom side alignment.

***BOOM EXTENSION** – 26 ft. – 46 ft. (7.9m – 14.0m) telescopic "Swingaway." 20 ft. (6.1m) rectangular roller mounted extension is manually extended and retracted from within 26 ft. (7.9m) lattice "Swingaway." (2° offset).

BOOM NOSE – Three sheaves, 13 3/4" (349mm), tread dia. mounted on heavy duty tapered roller bearings. Removable pin type rope guards permit easy reeving. Rope dead ends on each side of boom nose.

BOOM ELEVATION – Single, 10 in. (254mm) bore, double-acting hydraulic cylinder with integral holding valves; elevation from – 4° to 75°. Combination controls provided for hand or foot operation.

***LOAD MOMENT AND ANTI-TWO BLOCK SYSTEM (KRUGER)** – Audio-visual warning in combination with Grove control lever lock-out of; hoist up, telescope out and boom down functions.

CAB – Full vision, all steel, fully enclosed, acoustically treated with tinted tempered safety glass throughout (removable front windshield with storage provision and hinged skylight are tinted laminated safety glass). Sliding left side door and sliding right side window for ventilation. Adjustable full length control levers, combination hand and foot controls for swing and boom elevation. Fully adjustable operators seat with headrest. Complete engine instrumentation and controls. Combination hand and foot throttle. All-crane superstructure and outrigger controls, sight levelling bubble, electronic boom angle indicator, 20,000 BTU diesel fuel heater, electric windshield wiper, defroster fan and swing horn; door and window locks, domelight, 3 3/4 lbs. (1.7 kg.) dry type fire extinguisher.

CAB INSTRUMENTATION – Engine oil pressure and water temperature gauges, voltmeter, tachometer, fuel level gauge, ignition-on indicator light.

SWING – Ball bearing swing circle, 360° continuous rotation. Grove planetary "glide swing" with foot actuated disc swing brake, electric/hydraulic swing parking brake and 360° positive swing lock. Combination controls provided for hand or foot operation. Swing speed 2.7 RPM.

OUTRIGGER CONTROLS – Independently controlled in-out-up-and-down from superstructure cab. Sequence control arrangement virtually eliminates accidental outrigger actuation.

COUNTERWEIGHT – Stationary mounted on turntable (Not required with auxiliary hoist).

HYDRAULIC SYSTEM:

RESERVOIR – 86 gallons (326 liters) capacity, all-steel welded construction with integral baffles, clean out access, magnetic drain plug and exterior oil sight level.

FILTER – Return line type, full flow with by-pass protection and by-pass indicator, replaceable cartridge 25 micron rating.

PUMPS – Three section, gear type, PTO drive off transmission with disconnect operated from carrier cab. Combined capacity 112.5 GPM (426 lpm).

CONTROL VALVES – Precision four-way, double-acting with integral load check, main and circuit relief valves. Three individual valve banks permit simultaneous independent control of three crane functions. Maximum operating pressure 2500 PSI (176kg/cm²).

POWER DISTRIBUTION – [Swing, outriggers – 26.5 GPM (100 lpm)] [Main Hoist – 39.5 GPM (150 lpm)] [Boom elevation, telescope, auxiliary hoist, main hoist boost – 46.5 GPM (176 lpm)].

HOIST SPECIFICATIONS

DESCRIPTION: Power up and down, equal speed, planetary reduction with integral automatic brake.				
HOIST DATA	MAIN HOIST Grove Model 15H-16B	*MAIN HOIST Grove Model 25H-16	*AUXILIARY HOIST Grove Model 15S-16B	*AUXILIARY HOIST Geramatic Model 11 SGECR (Controlled Free Fall)
Drum Dimensions	12 in. dia. (305mm) 16 in. length (406mm) 17.5 in. flange dia. (445mm)	16 in. dia. (406mm) 16 in. length (406mm) 24 in. flange dia. (610mm)	12 in. dia. (305mm) 16 in. length (406mm) 17.5 in. flange dia. (445mm)	9 in. dia. (229mm) 13 in. length (330mm) 17.5 in. flange dia. (445mm)
PERFORMANCE: Max. Single Line Speed Max. Single Line Pull	352 FPM (107.3m/min) 9,165 lbs. (4157 kg.)	470 FPM (143.3m/min) 9,610 lbs. (4359 kg.)	198 FPM (60.4m/min) 9,165 lbs. (4147 kg.)	290 FPM (88.4m/min) 9,145 lbs. (4148 kg.)
Drum Rope Storage Capacity	**720 ft. of 1/2" dia. rope (219.5m of 13mm)	**1285 ft. of 1/2" dia. rope (391.7m of 13mm)	**720 ft. of 1/2" dia. rope (219.5m of 13mm)	**675 ft. of 1/2" dia. rope (205.7m of 13mm)
Permissible Single Line Rope Pull	1/2 in. (13mm) 19x7 class 6,150 lbs. (2790 kg.) 1/2 in. (13mm) 6x37 class 7,600 lbs. (3477 kg.)	1/2 in. (13mm) 19x7 class 6,150 lbs. (2790 kg.) 1/2 in. (13mm) 6x37 class 7,600 lbs. (3477 kg.)	1/2 in. (13mm) 19x7 class 6,150 lbs. (2790 kg.) 1/2 in. (13mm) 6x37 class 7,600 lbs. (3477 kg.)	1/2 in. (13mm) 19x7 class 6,150 lbs. (2790 kg.) 1/2 in. (13mm) 6x37 class 7,600 lbs. (3477 kg.)

**6th layer of rope not recommended for hoisting operations. (8th layer with 25H-16 main hoist)

*Denotes optional equipment. Auxiliary hoist control valve arrangement is standard equipment.

AXLE WEIGHT DISTRIBUTION CHART

ITEM	POUNDS			KILOGRAMS		
	GROSS	FRONT	REAR	GROSS	FRONT	REAR
Basic standard machine to include: 32 ft. – 80 ft. (9.8m – 24.4m) trapezoidal boom, 26 ft. (7.9m), swingaway extension, Grove 15H-16A main hoist, 400 ft. (121.9m) of 1/2 in. (13mm) rope, counterweight, Grove 6 x 4 carrier, Cummins V8-210 engine.	44,238	14,640	29,598	20,066	6,691	13,425
ADD:						
25 ton, 3 sheave hook block (travel position)	+561	-730	169	-254	+331	77
7 1/2 ton headache ball	+300	-320	20	-136	-145	9
5 ton headache ball	+150	-160	10	-68	+73	-5
Auxiliary boom head	+106	+176	-70	+48	+80	32
••Grove 15S-16A auxiliary hoist with 350 ft. (106.7m) of 3/8 in. (16mm) dia. rope	-228	+163	-391	-103	+74	-177
••Gearmatic 11 SGECR auxiliary hoist with 350 ft. (106.7m) of 1/2 in. (13mm) dia. rope	-208	+154	-362	-94	-70	-164
Kruger load moment and anti-two block system	+376	+96	+280	+171	+44	+127
SUBSTITUTE:						
26 ft. – 46 ft. (7.9m – 14m) telescopic extension	+695	+534	+161	+315	-242	-73
•Grove 25H-16 main hoist with 400' (121.9m) of 5/8" (16mm) rope	+1003	-549	+1552	+455	-249	+704
GM6V-53N engine	+100	+90	+10	+45	+41	+4
Caterpillar 3208 engine	-50	45	-5	-22	-20	2
REMOVE:						
26 ft. (7.9m) swingaway extension	-1,071	-846	-225	-486	384	-102
•Standard counterweight used on units with no auxiliary hoist	-1,200	+604	1,804	-544	-274	818

Notes: •1,200 lbs. (544kg) counterweight used without auxiliary hoist
••No counterweight used with auxiliary hoist



CARRIER SPECIFICATIONS

Grove Carrier 6x4

OUTRIGGERS – Hydraulic, double box telescoping beam outriggers front and rear 5½" (140mm) bore diameter. Vertical jack cylinders equipped with integral holding valves and 24 in. (610mm) dia. light-weight steel floats. Beams extends to 18 ft. (5.5m) centerline to centerline, retract to 8 ft. (2.4m) overall width by 3" (76mm) bore diameter extension cylinder. Complete controls and sight leveling indicator located in superstructure cab.

FRAME – High-strength steel, all welded construction with triple box type design and integral outrigger boxes.

STEERING – Sheppard Model 592 rack and pinion design with power assist.

CLUTCH – Lipe Rollway 14 in. (356mm), single plate dry disc. Lining area: 218 sq. in. (1407cm²).

TRANSMISSION – Fuller Roadranger RTO 613, 13 speeds forward and 3 reverse (RT613 used with V8-210 engine). Single lever shift control with 3 position air shift range selector; neutral safety start.

UNIVERSAL JOINTS – Needle bearing type.

AXLES – Front: Single non-driving I-beam, Rockwell FL-931, 18,000 lbs. (8165kg) capacity. Rear: Rockwell SLHD single reduction tandem, 34,000 lbs. (15 422kg) capacity with inter-axle differential and dash-mounted control.

SUSPENSION – Front: Reyco spring mounted with shock absorbers. Rear: Hendrickson solid mounted tandem.

FUEL TANK – Single 60 gallon (227 liter) capacity mounted on left side of frame.

TIRES – Front: (2) 15 x 22.5 – 16 ply duplex hi-way tread, tubeless (12.00 x 20 or 16.5 x 22.5 tires – optional). Rear: (8) 9.00 x 20 – 10 ply hi-way tread, tube-type (15.00 x 22.5 or 16.5 x 22.5 duplex singles – optional).

WHEELS – Front: Steel spoke, 12.25 in. x 22.5 in. rims (311mm x 572mm). Rear: Steel spoke, 7 in. x 20 in. rims (178mm x 508mm).

BRAKES – Full air on all wheels with air dryer.
Total lining area: 1256 sq. in. (8104cm²).
Front: 15 in. x 6 in. (381mm x 152mm). Rear: 15 in. x 7 in. (381mm x 178mm) "Complies with FMVSS121 (Air Brake Systems)".

PARKING BRAKE – Spring set emergency chambers on both rear axles with dash mounted release kit.

ELECTRICAL SYSTEM – 24 volt starting, 12 volt lighting, U.S. federal safety standard lights and reflectors.

CAB – One man, all-steel with acoustical treatment, laminated safety glass windshield and windows, electric windshield washer, wiper and defroster fan, door and window locks. Bostrom T-bar seat with belt, dual rear view mirrors, domelight, dashlight, hot water heater, electric horn, traffic hazard warning switch (four-way flasher) complete engine instrumentation and carrier driving controls, 3¾ lbs. (1.7kg) dry type fire extinguisher.

CAB INSTRUMENTATION – Electric tachometer, engine oil pressure and water temperature gauges, voltmeter, speedometer, air pressure gauge, electric fuel gauge, high beam indicator, low air pressure audio-visual warning, ignition-on indicator, pump engaged indicator.

MISCELLANEOUS STANDARD EQUIPMENT – Wheel nut wrench and handle, channel front bumper, two front and rear towing loops, front and rear fenders, either injections starting aid (less canister), mud flaps, sling box, boom rest, hookblock tie down.

SPEED AND GRADEABILITY

Engine	Speed Ranges	% of Gradeability (at Max. Torque)
Cummins V8-210	3.79 to 68.65 MPH (6.1 to 110.5km/h)	33.36 to .42%
*GM6V-53N	3.52 to 63.75 MPH (5.7 to 102.6km/h)	34.27 to .47%
*Caterpillar 3208	3.52 to 63.75 MPH (5.7 to 102.6km/h)	35.71 to .55%

NOTE: Performance based on 48,000 lbs. (21 773 kg) GVW and standard SAE engine rating conditions using standard tires, transmissions and axles. Performance data may vary plus or minus 10% due to variations in engine performance and vehicle weights. Maximum speed restricted to 60 mph (96.5 km/h) due to tire limitations.

Meets requirements of P.C.S.A. Standard No. 2.

NOTE: Dimensions in parenthesis are millimeters (mm).

ENGINE SPECIFICATIONS

MAKE & MODEL TYPE	Cummins V8-210 8 Cylinder O.H.V. 4.625 in. x 3.75 in. (117mm x 95mm)	*GM6V-53N 6 Cylinder O.H.V. 3.875 in. x 4.5 in. (98mm x 114mm)	*Caterpillar 3208 8 Cylinder O.H.V. 4.5 in. x 5.0 in. (114mm x 127mm)
BORE & STROKE			
DISPLACEMENT	504 cu. in. (8259cm ³)	318 cu. in. (5212cm ³)	636 cu. in. (10 424cm ³)
HORSEPOWER (NET)	160 @ 2800 RPM	176 @ 2600 RPM	160 @ 2600 RPM
GOVERNED RPM	2800 RPM	2600 RPM	2600 RPM
TORQUE (NET)	343 lbs. ft. @ 1900 RPM (47kg.m)	397 lbs. ft. @ 1800 RPM (55kg.m)	413 lbs. ft. @ 1200 RPM (57kg.m)
ELECTRICAL SYSTEM	12 Volt Neg. Ground	12 Volt Neg. Ground	12 Volt Neg. Ground
COMBUSTION SYSTEM	4 cycle, naturally aspirated	2 cycle, with blower	4 cycle, naturally aspirated
COOLING SYSTEM	Liquid	Liquid	Liquid
FUEL CAPACITY	60 Gallons (227 liters)	60 Gallons (227 liters)	60 Gallons (227 liters)
ALTERNATOR	90 Amp 12 Volt	90 Amp 12 Volt	90 Amp 12 Volt
BATTERY	(4) 12v., 1900 cold cranking Amps @ 0°F	(4) 12v., 1900 cold cranking Amps @ 0°F	(4) 12v., 1900 cold cranking Amps @ 0°F
AIR CLEANER	Dry Type	Dry Type	Dry Type
AIR COMPRESSOR	13.2 CFM (374 L/min)	12 CFM (340 L/min)	12 CFM (340 L/min)
HOURLY METER	Std.	Std.	Std.
STARTING SYSTEM	24 volt	24 volt	24 volt

Note: Jacobs Engine Brake (GM and Cummins) is optional.

*Denotes Optional Equipment

DIMENSIONS

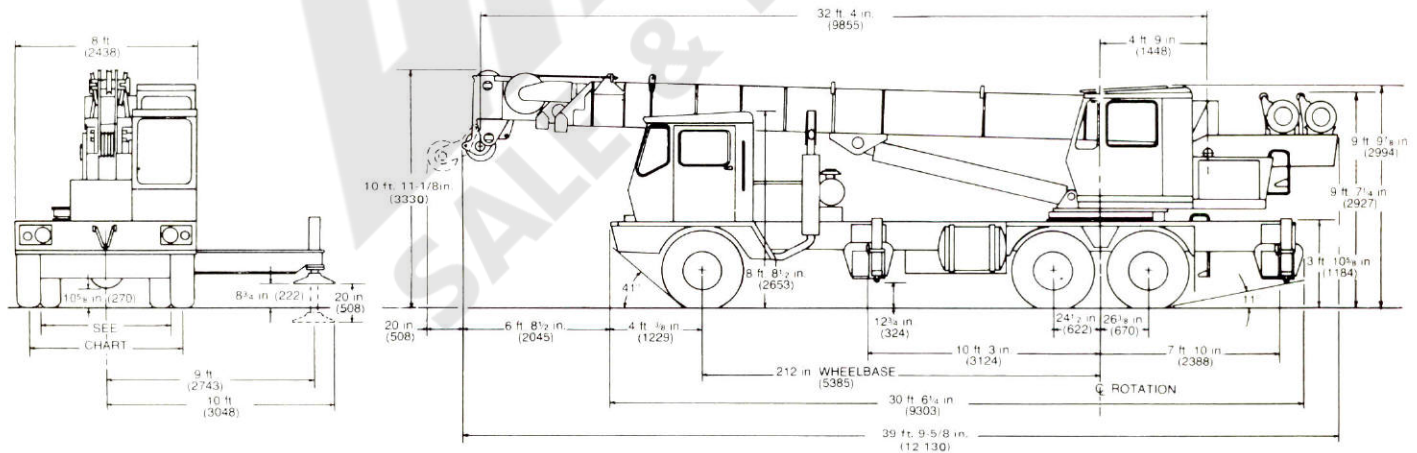

FRONT TIRE SIZE	FRONT TRACK	TURNING RADIUS	REAR TIRE SIZE	REAR TRACK
15:00 x 22.5	81 7/8" (2080)	32' 4" (9855)	9:00 x 20	72" (1829)
*16.5 x 22.5	81 7/8" (2080)	32' 4" (9855)	*15.5 x 22.5	72 3/4" (1848)
*12:00 x 20	78 5/8" (1997)	32' (9754)	*16.5 x 22.5	72 3/4" (1848)

TAIL SWING – 11 ft. 5-1/16 in. (3491)

Constant improvement and engineering progress make it necessary that we reserve the right to make specification, equipment, and price changes without notice.

Meets requirements of P.C.S.A. Standard No. 2.

NOTE: Dimensions in parenthesis are millimeters (mm).

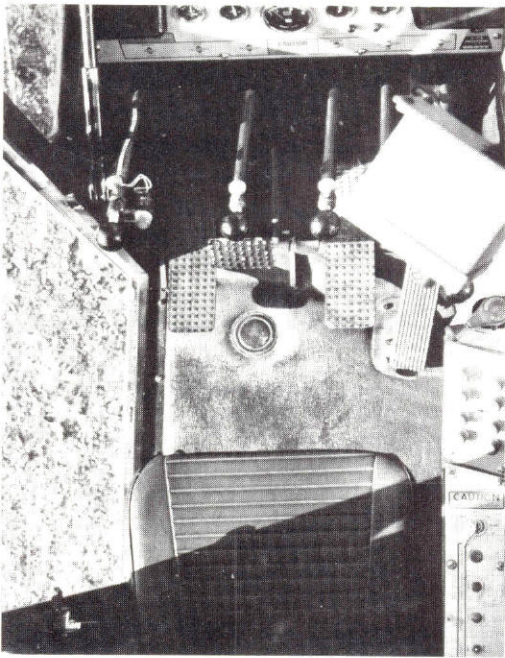

GROVE HOISTS

... Both main and auxiliary hoists are of Grove design and manufacture except for the optional free fall hoist. They are planetary gear drive, power up and down, equal speed with integral automatic brake. Hoisting and lowering speeds can be controlled from zero to maximum under all load conditions.



DESIGNED FOR COMFORT AND EFFICIENCY

... The interior of the all-steel cab is designed for operator convenience, efficiency and safety. Full length control levers are adjustable and combination hand and foot controls are provided for swing, boom elevation and throttle. Full engine controls and instruments are provided. Other features include a sliding door, laminated safety glass windows, removable windshield and hinged skylight, acoustical treatment and electronic boom angle indicator.

18 FOOT OUTRIGGER SPREAD

... Double-box beam outriggers, integral with the frame, provide an 18 ft. (5.5m) spread for maximum stability. Beams and jacks are independently controlled from the superstructure cab. Stowable, 24 inch (610mm) diameter steel outrigger pads assure excellent ground contact.

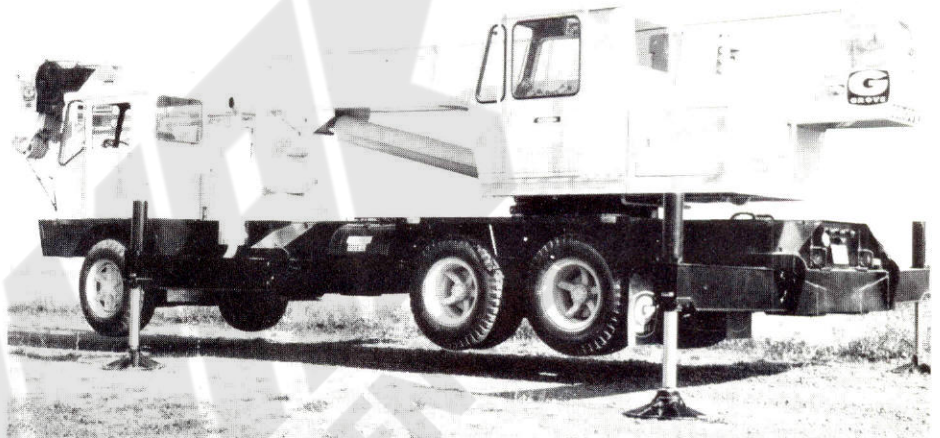

THE MOST COMPLETE LINE OF MOBILE HYDRAULIC CRANES

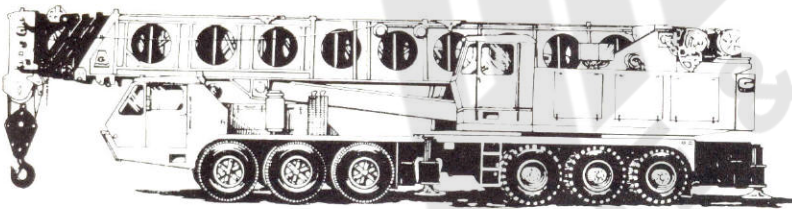

CARRIER MOUNTED CRANES 15 through 140 tons
(18 through 130 tons metric)

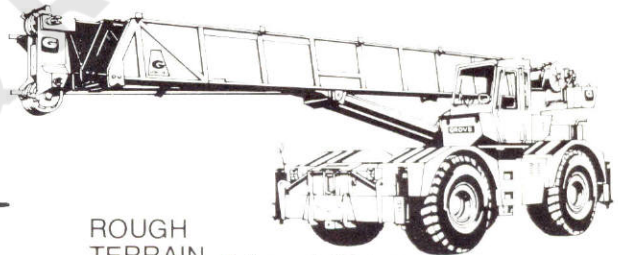

ROUGH TERRAIN CRANES 8 through 80 tons
(7.3 through 72.5 tons metric)



HYDRAULIC CRANES

GROVE MANUFACTURING CO.

Division of Walter Kidde & Company, Inc.
SHADY GROVE, PA. 17256 USA



TMS185A

18 TON CAP.

32 ft. - 106 ft. BOOM
85% OF TIPPING

JIB CAPACITIES IN POUNDS 22 ft. JIB and 26 ft. EXT. Combination OVER SIDE AND REAR

Main Boom Angle	5° OFFSET		17° OFFSET		30° OFFSET	
	Re Radius	Cap	Re Radius	Cap	Re Radius	Cap
75	37.4	6,500	41.5	6,000	46.3	5,000
70	44.9	5,200	49.3	4,800	53.5	4,400
65	54.9	4,200	59.1	4,000	62.7	3,700
60	64.4	3,160	68.4	2,900	71.3	2,510
55	73.5	2,060	77.2	2,000	79.5	1,350
50	81.9	1,260	85.3	1,230	87.0	1,080

A6-829-003726B

ON OUTRIGGERS FULL

Radius in Feet	Main Boom Length				
	*32	38	44	50	56
10	36,000 (64)	36,000 (68)	36,000 (72)		
12	36,000 (60)	36,000 (65)	36,000 (69)	36,000 (72)	36,000 (74.5)
15	36,000 (53.5)	36,000 (59.5)	36,000 (64.5)	36,000 (68.5)	36,000 (71)
20	30,000 (41.5)	30,000 (50.5)	30,000 (57)	30,000 (62)	30,000 (65.5)
25	20,480 (24.5)	20,480 (39.5)	20,480 (48.5)	20,480 (55)	20,480 (59.5)
30		14,070 (25)	14,070 (39)	14,070 (47)	14,070 (53)
35			10,240 (26.5)	10,240 (38.5)	10,240 (46)
40				8,100 (27.5)	8,100 (38)
45				6,420 (6.5)	6,420 (28)
50					4,970 (13)
55					
60					
65					
70					
74					
80					
85					
90					

Min. Boom Angle (deg.) for indicated boom length
Max. Boom Length (ft.) at 0 degree boom angle (no

- 22 ft. jib and 26 ft. boom extension combination may be used for single line lifting crane service only. Capacities are based on structural strength of 22 ft. and 26 ft. boom extension combination at given main boom angle regardless of main boom length. When lifting with 22 ft. jib and 26 ft. boom extension, capacities must not exceed structural capacity of jib combination at given main boom angle or stability capacity of applicable boom length listed in boom capacity chart for actual working radius, whichever is less.
- WARNING:** Operation of machine with heavier loads than the capacities listed is strictly prohibited. Machine tipping with jib occurs rapidly and without advance warning.
- Maximum total length of boom including 26 ft. boom extension for purpose of erecting 22 ft. jib below 10° elevation is 94 ft.
- 22 FT. JIB WARNING:** For total boom length including 26 ft. boom extension greater than 94 ft. with 22 ft. jib in working position, the boom angle must not be less than 45° since loss of stability will occur causing a tipping condition.

Note: 22 ft. A Frame jib for use only with 26 ft. round tube swingaway.

LIFTING AREA DIAGRAM

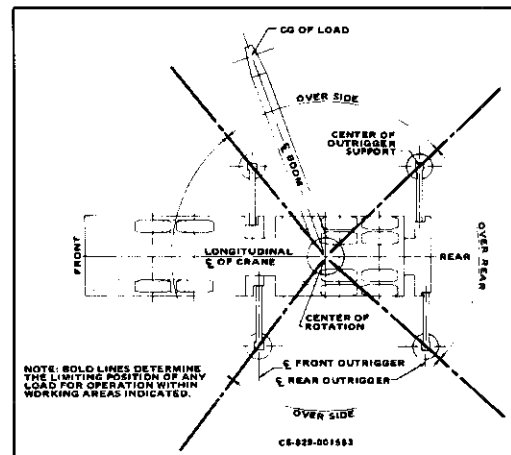

NOTES:

- Capacities appearing above bold line are based on capacity limitation. Capacities do not exceed 85% SAE J-765.
- *Capacities for 32 ft. boom length shall be lifted - capacities shall not exceed those shown for the 38 ft
- **For boom lengths less than fully extended while boom angle:
- For 26 ft. boom ext., use only the column head
 - For 26 ft. boom ext. and 22 ft. jib combination,
 - For 26 ft. - 46 ft. telescopic boom ext. (retracted)
 - For 26 ft. - 46 ft. telescopic boom ext. (erected)
- For boom angles not shown, use rating of next lower boom angle is the included angle between horizon lifting rated load.



TMS185A
18 TON CAPACITY
32 ft. - 106 ft. BOOM
(FULL POWER)
PCSA CLASS 10-81
85% OF TIPPING

RATED LIFTING CAPACITIES IN POUNDS

32 ft. - 106 ft. BOOM

ON OUTRIGGERS FULLY EXTENDED - OVER SIDE

Radius in Feet	Main Boom Length in Feet										26 ft. Ext. + 80 ft. (2°Offset)	26-46 ft. Tele. Ext. & 80 ft. (2°Offset)	
	*32	38	44	50	56	62	68	74	80	**106	**106	**126	
10	36,000 (64)	36,000 (68)	36,000 (72)										
12	36,000 (60)	36,000 (65)	36,000 (69)	36,000 (72)	36,000 (74.5)								
15	36,000 (53.5)	36,000 (59.5)	36,000 (64.5)	36,000 (68.5)	36,000 (71)	28,200 (72.5)	26,000 (74.5)						
20	30,000 (41.5)	30,000 (50.5)	30,000 (57)	30,000 (62)	30,000 (65.5)	24,500 (67.5)	23,000 (70)	21,500 (72.5)	20,000 (73.5)				
25	20,480 (24.5)	20,480 (39.5)	20,480 (48.5)	20,480 (55)	20,480 (59.5)	20,480 (62.5)	18,500 (65.5)	18,200 (68)	17,500 (69.5)	10,000 (75)	9,370 (75)		
30		14,070 (25)	14,070 (39)	14,070 (47)	14,070 (53)	14,070 (57)	14,070 (60.5)	14,070 (63.5)	14,070 (65.5)	9,550 (73)	8,950 (73)		
35			10,240 (26.5)	10,240 (38.5)	10,240 (46)	10,240 (51)	10,240 (55.5)	10,240 (59)	10,240 (61.5)	8,360 (70)	7,760 (70)	3,250 (74.5)	
40				8,100 (27.5)	8,100 (38)	8,100 (44.5)	8,100 (50)	8,100 (54.5)	8,100 (57)	7,410 (67)	6,810 (67)	3,080 (72.5)	
45				6,420 (6.5)	6,420 (28)	6,420 (37.5)	6,420 (44)	6,420 (49)	6,420 (52.5)	6,630 (63.5)	6,030 (64)	2,920 (70)	
50					4,970 (13)	4,970 (29)	4,970 (37.5)	4,970 (43.5)	4,970 (48)	5,980 (60.5)	5,380 (60.5)	2,760 (67.5)	
55						3,810 (16.5)	3,810 (29.5)	3,810 (37.5)	3,810 (42.5)	5,180 (57.5)	4,780 (57.5)	2,600 (65)	
60							2,980 (18.5)	2,980 (30)	2,980 (36.5)	4,040 (54)	3,670 (54)	2,450 (62.5)	
65								2,250 (20.5)	2,250 (30)	3,240 (50.5)	2,840 (50.5)	2,320 (59.5)	
70									1,750 (21)	2,580 (46.5)	2,070 (46.5)	2,200 (57)	
74									1,500 (10.5)	2,120 (43.5)	1,620 (43.5)	2,120 (54.5)	
80										1,580 (38)	1,070 (38)	2,010 (51)	
85										1,170 (33.5)		1,620 (48)	
90												1,230 (45)	
Min. Boom Angle (deg.) for indicated boom length (no load)										0	5	35	40
Max. Boom Length (ft.) at 0 degree boom angle (no load)										80	105	86	96

Radius in Feet	Main Boom Length in Feet	
	*32	38
10	36,000 (64)	36,000 (68)
12	36,000 (60)	36,000 (65)
15	36,000 (53.5)	36,000 (59.5)
20	30,000 (41.5)	30,000 (50.5)
25	22,700 (24.5)	22,700 (24.5)
30		17,800 (25)
35		
40		
45		
50		
55		
60		
65		
70		
74		
80		
85		
90		
95		
100		
105		
110		
115		
120		
Min. Boom Angle (deg.)		
Max. Boom Length (ft.)		

A6-829-003636.- 003848 & -002997C
-003732A

NOTES:

- Capacities appearing above bold line are based on structural strength and tipping should not be relied upon as a capacity limitation. Capacities do not exceed 85% of tipping loads as determined by test in accordance with SAE J-765.
 - *Capacities for 32 ft. boom length shall be lifted with boom fully retracted. If the boom is not fully retracted, capacities shall not exceed those shown for the 38 ft. boom length.
 - **For boom lengths less than fully extended while boom extension is erected, the rated loads are determined by boom angle:
 - a. For 26 ft. boom ext., use only the column headed by 106 ft. boom.
 - b. For 26 ft. boom ext. and 22 ft. jib combination, see note No. 1 on jib capacity chart A6-829-003726.
 - c. For 26 ft. - 46 ft. telescopic boom ext. (retracted), use only the column headed by 106 ft. boom.
 - d. For 26 ft. - 46 ft. telescopic boom ext. (erected), use only the column headed by 126 ft. boom.
- For boom angles not shown, use rating of next lower boom angle.
Boom angle is the included angle between horizontal and the longitudinal axis of the boom base section after lifting rated load.

A
CITY
ROOM

GROVE®

FULL HYDRAULIC

CARRIER-MOUNTED CRANE

CAPACITIES IN POUNDS
BOOM

ON OUTRIGGERS FULLY EXTENDED - OVER REAR

Radius in Feet	Main Boom Length in Feet									26 ft. Ext. + 80 ft. (2° Offset)	26-46 ft. Tele. Ext. & 80 ft. (2° Offset)		
	*32	38	44	50	56	62	68	74	80	**106	**106	**126	
10	36,000 (64)	36,000 (68)	36,000 (72)										
12	36,000 (60)	36,000 (65)	36,000 (69)	36,000 (72)	36,000 (74.5)								
15	36,000 (53.5)	36,000 (59.5)	36,000 (64.5)	36,000 (68.5)	36,000 (71)	28,200 (72.5)	26,000 (74.5)						
20	30,000 (41.5)	30,000 (50.5)	30,000 (57)	30,000 (62)	30,000 (65.5)	24,500 (67.5)	23,000 (70)	21,500 (72.5)	20,000 (73.5)				
25	22,700 (24.5)	22,700 (39.5)	22,700 (48.5)	22,700 (55)	22,700 (59.5)	20,800 (62.5)	18,500 (65.5)	18,200 (68)	17,500 (69.5)	10,000 (75)	9,370 (75)		
30		17,800 (25)	17,800 (39)	17,800 (47)	17,800 (53)	17,400 (57)	16,100 (60.5)	15,800 (63.5)	14,900 (65.5)	9,550 (73)	8,950 (73)		
35			14,400 (26.5)	14,400 (38.5)	14,400 (46)	14,400 (51)	14,200 (55.5)	13,700 (59)	12,900 (61.5)	8,360 (70)	7,760 (70)	3,250 (74.5)	
40				11,620 (27.5)	11,620 (38)	11,620 (44.5)	11,620 (50)	11,620 (54.5)	11,400 (57)	7,410 (67)	6,810 (67)	3,080 (72.5)	
45					9,490 (28)	9,490 (37.5)	9,490 (44)	9,490 (49)	9,490 (52.5)	6,630 (63.5)	6,030 (64)	2,920 (70)	
50					7,940 (13)	7,940 (29)	7,940 (37.5)	7,940 (43.5)	7,940 (48)	5,980 (60.5)	5,380 (60.5)	2,760 (67.5)	
55						6,720 (16.5)	6,720 (29.5)	6,720 (37.5)	6,720 (42.5)	5,430 (57.5)	4,820 (57.5)	2,600 (65)	
60							5,860 (18.5)	5,860 (30)	5,860 (36.5)	4,960 (54)	4,350 (54)	2,450 (62.5)	
65								4,920 (20.5)	4,920 (30)	4,550 (50.5)	3,940 (50.5)	2,320 (59.5)	
70									4,270 (21)	4,200 (46.5)	3,590 (46.5)	2,200 (57)	
74									3,940 (10.5)	3,940 (43.5)	3,330 (43.5)	2,120 (54.5)	
80										3,570 (38)	3,000 (38)	2,010 (51)	
85										3,100 (33.5)	2,580 (33.5)	1,920 (48)	
90										2,660 (27.5)	2,140 (27.5)	1,850 (45)	
95										2,240 (20.5)	1,730 (21)	1,780 (41.5)	
100										1,880 (8.5)	1,330 (10.5)	1,720 (37.5)	
105												1,670 (33)	
110												1,620 (28)	
115												1,320 (22)	
120												1,060 (12)	
Min. Boom Angle (deg.) for indicated boom length (no load)										2	3	4	5
Max. Boom Length (ft.) at 0 degree boom angle (no load)										79	105.5	105.5	125

RANGE DIAGRAMS

WITH 26 - 46 ft. TELE. EXT.

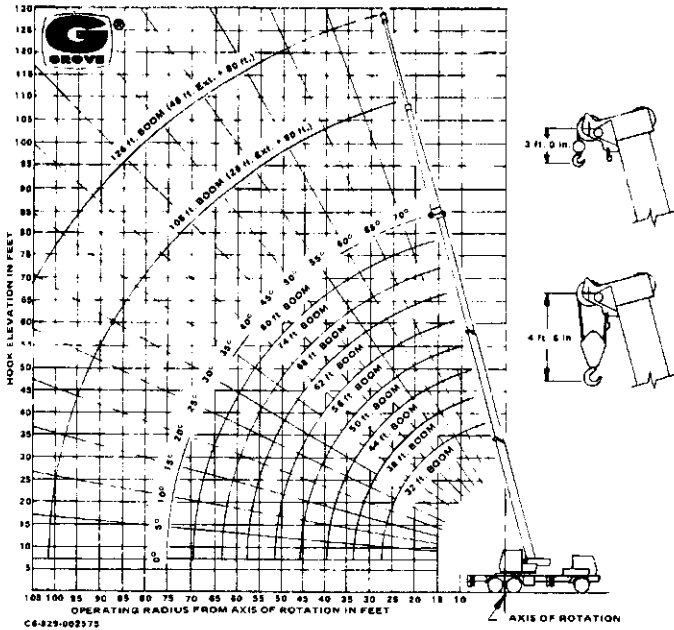

WITH 26 ft. EXT. & 22 ft. JIB

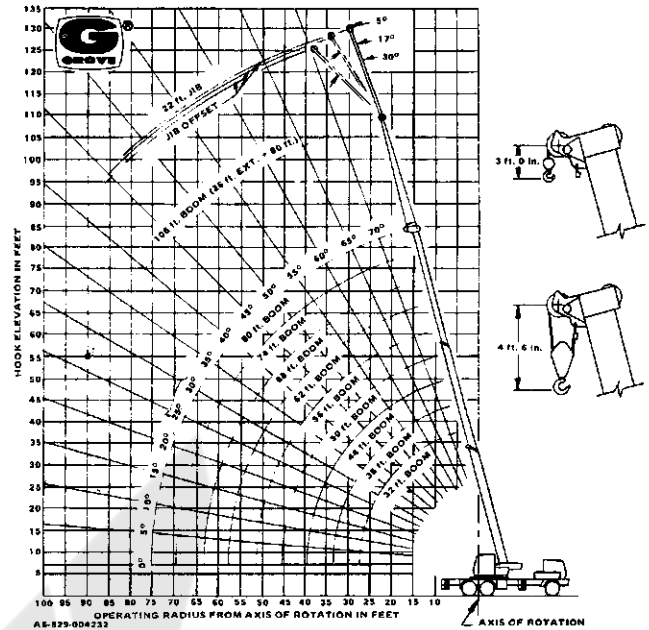

WEIGHT REDUCTIONS FOR LOAD HANDLING DEVICES

26 ft. BOOM EXTENSION

26 ft. Boom Extension with 32-80 ft. Boom
† Stowed - 461 lbs.
† Erected - 1,850 lbs.

26-46 Tele. Boom Ext. with 32-80 ft. Boom

† Stowed - 400 lbs.
† Erected - 2,700 lbs. (26 ft. retracted)
† Erected - 3,450 lbs. (46 ft. extended)
† Reduction of main boom capacities.

22 ft. JIB

22 ft. Jib & 26 ft. Boom Ext. Combination
† Stowed - 704 lbs.
† Erected - 4,260 lbs.
†† Erected - 1,115 lbs.
22 ft. Jib Only Stowed on Base Section
† Stowed - 243 lbs.
†† Stowed - 243 lbs.

† Reduction of main boom capacities.
†† Reduction of 26 ft. Ext. capacities.

25 Ton, 3 Sheave Hookblock	- 516 lbs.
25 Ton, 4 Sheave Hookblock	- 561 lbs.
7 1/2 Ton Headache Ball	- 300 lbs.
5 Ton Headache Ball	- 150 lbs.
Auxiliary Boom Head	- 110 lbs.

NOTE: All Load Handling Devices and Boom Attachments are Considered Part of the Load and Suitable Allowances MUST BE MADE for Their Combined Weights. Weights are for Grove furnished equipment.

NOTES TO LIFTING CAPACITIES

- Do not exceed any rated lifting capacity. Rated lifting capacities are based on freely suspended loads with the machine leveled and standing on a firm supporting surface. Ratings with outriggers are based on outriggers being extended to their maximum position and tires raised free of crane weight before extending the boom or lifting loads.
- Practical working loads for each particular job shall be established by the user depending on operating conditions; including the supporting surface, wind and other factors affecting stability, hazardous surroundings, experience of personnel, handling of load, etc. No attempt must be made to move a load horizontally on the ground in any direction.
- Operating radius is the horizontal distance from the axis of rotation before loading to the centerline of the vertical hoist line or tackle with loads applied.
- "On Rubber" lifting (if permitted) depends on proper tire inflation, capacity, and condition. "On Rubber" loads may be transported at a maximum vehicle speed of 2.5 mi/hr (4 Km/hr) on a firm and level surface under conditions specified.
- Jibs may be used for lifting crane service only. Jib capacities are based on structural strength of jib or main boom and on main boom angle.
- Operation is not intended or approved for any conditions outside of those shown hereon. Handling of personnel from the boom is not authorized except with equipment furnished and installed by Grove Manufacturing Company.
- For clamshell or concrete bucket operation, weight of bucket and load must not exceed 80% of rated lifting capacities.
- Power-telescoping boom sections must be extended equally at all times. Long cantilever booms can create a tipping condition when in extended and lowered position.
- The maximum load which may be telescoped is limited by hydraulic pressure, boom angle, boom lubrication, etc. It is safe to attempt to telescope any load within the limits of rated lifting capacity chart.
- With certain boom and hoist tackle combinations, maximum capacities may not be obtainable with standard cable lengths.
- With certain boom and load combinations, raising of load with boom lift cylinders may not be possible. Operational safety is not affected by this condition.
- Keep load handling devices a minimum of 12 inches (30 cm) below boom head when lowering or extending boom.
- If actual boom length and/or radius are between values listed, use lifting capacity for the next longer rated length and/or radius.
- All load handling devices and boom attachments are considered part of the load and suitable allowances must be made for their combined weights.
- Operation of this equipment in excess of rating charts or disregard of the instructions is hazardous and voids the warranty and manufacturer's liability.



GROVE MANUFACTURING COMPANY
Division of Walter Kidde & Company Inc.
KIDDE

Box 21, Shady Grove, Pennsylvania 17256

Distributed by: