

GROVE®

MASTER
FILE

**FULL
HYDRAULIC
MOBILE CRANE**

**MODEL
TD150**

6 X 4 and 6 X 6



Specifications

- ★ 30,000 lbs. Capacity
- ★ 24-60 ft. Full-Power Telescoping Boom
- ★ Single Engine, PTO-Driven Hydraulic System
- ★ TWIN Boom Elevation Cylinders [0° to 75°]
- ★ 360° Continuous Rotation
- ★ Crane Controls in Cab





TD150

Hook Elevation

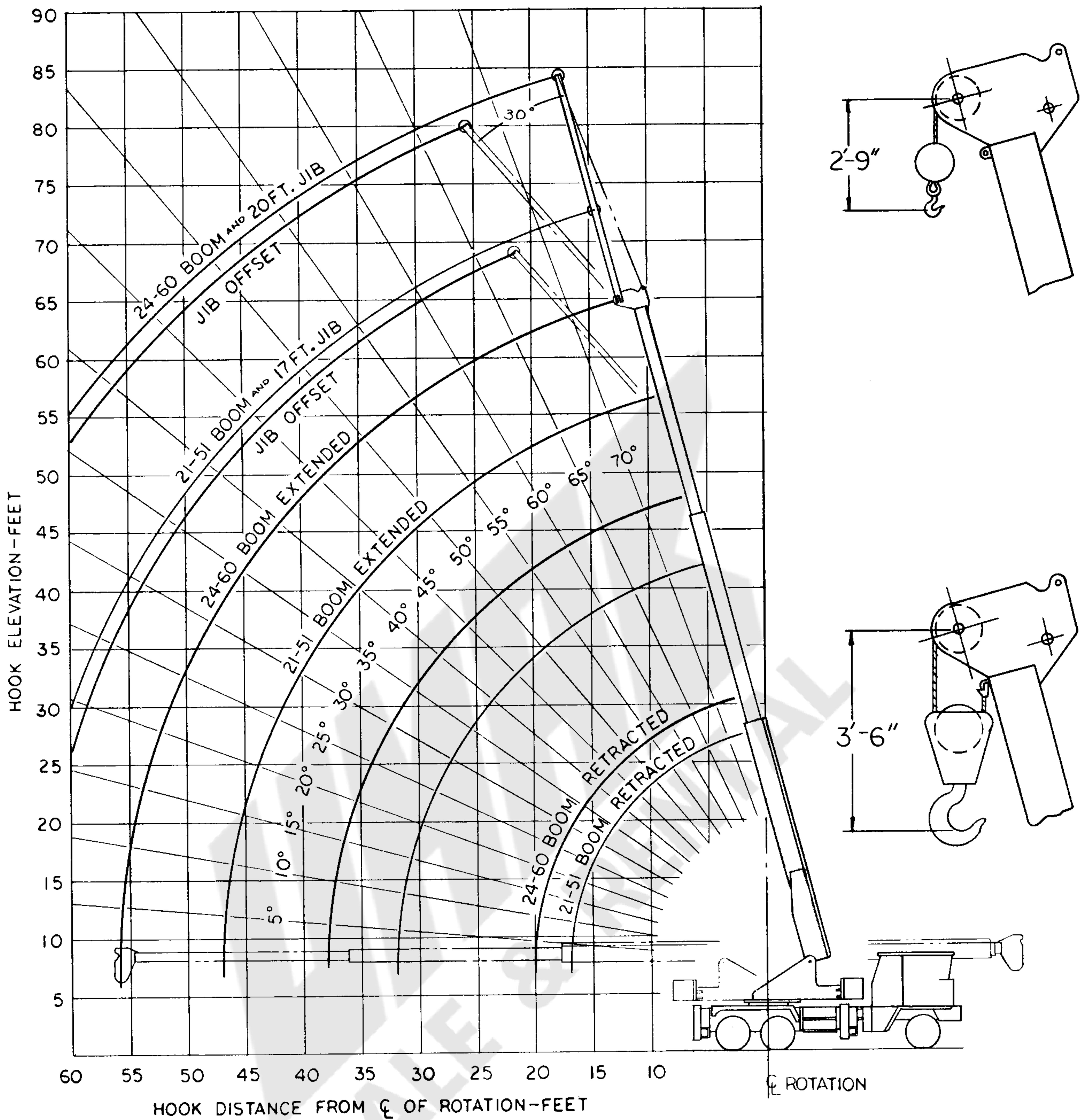

JIB CAPACITIES

Min. Boom Angle	No Offset	Max. Offset
75°	8500#	6300#
70°	5750	4300
65°	4500	3400
60°	3700	2800
50°	2200	1650
40°	1750	1460
30°	1500	1200



TD150

TD150 RATED LIFTING CAPACITIES

RADIUS IN FEET	OVER REAR		OVER SIDE	
	WITH OUTRIGGERS	WITHOUT OUTRIGGERS	WITH OUTRIGGERS	WITHOUT OUTRIGGERS
*10	30,000#	19,000#	30,000#	17,200#
*12	30,000	14,800	30,000	12,300
†15	26,000	10,650	26,000	8,500
20	21,600	6,900	20,600	4,800
25	16,000	4,800	13,250	3,100
30	12,000	3,300	9,750	2,200
35	9,200	2,150	7,750	1,600
40	7,400	1,300	6,300	1,200
45	6,100	800	5,000	800
50	5,000	350	4,100	350
55	4,300		3,500	

CAPACITIES APPEARING IN SHADED AREA ARE BASED ON MACHINERY STRENGTH AND TIPPING SHOULD NOT BE RELIED UPON AS A CAPACITY LIMITATION.

* For 30,000 Lbs. Lifting Capacity, Maximum boom length 45 Ft.

† For 26,000 Lbs. Lifting Capacity, Maximum boom length 50 Ft.

NOTES

- Rated lifting capacities, with or without outriggers, are the maximum loads covered by the manufacturer's warranty with the machine standing on a firm, level and uniform supporting surface. Capacities do not exceed 85% of tipping.
- For certain conditions, capacities are controlled by machinery strength. In these cases machine tipping must not be relied upon as the capacity limitation.
- For clamshell and concrete bucket operation, weight of bucket and load should not exceed 90% of outrigger lifting capacities.
- The weights of all load-handling devices are considered part of the load lifted and suitable allowances for them should be made.
- Boom jib extensions may be used as straight gooseneck extensions, and for lifting crane service only.
- With jib installed, lifting capacities over main boomhead must be reduced as follows:

JIB LENGTH	REDUCED CAPACITY
17 ft.	600 lbs.
20 ft.	700 lbs.
- The maximum boom length, including jib extension, may be raised from horizontal with outriggers set.
- Long cantilever booms can create a tipping condition when in extended and lowered positions. Boom should be retracted proportionate to the capacity of the load chart.
- Single line capacity 6000#. For larger capacities use multiple part reeving, (one additional line for each 6000# of capacity.)
- Each power-telescoping boom section should be extended equally at all times. Do not operate one fully extended and another fully retracted.

TD150 DIMENSIONAL CHART

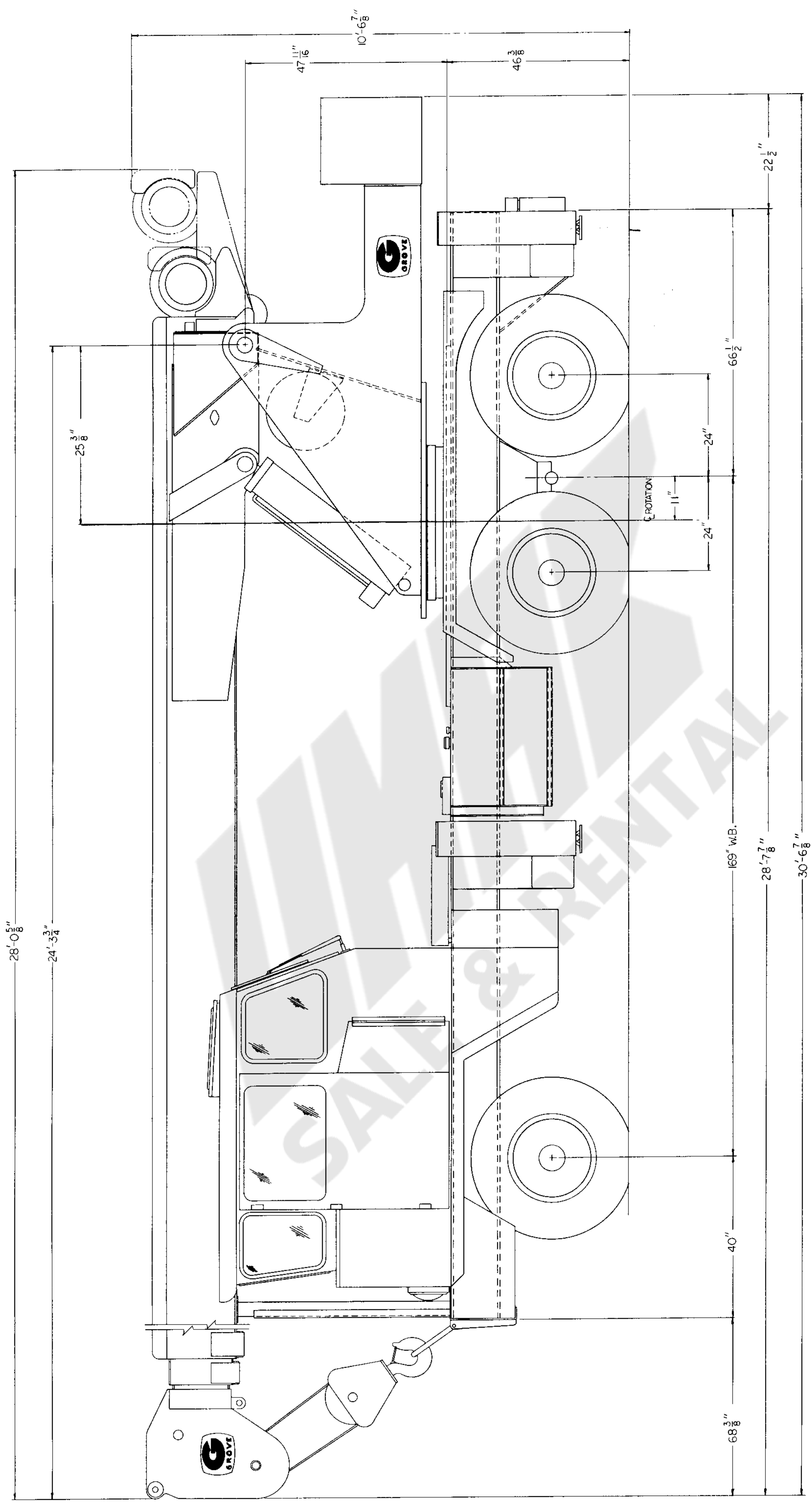

TD150

TD150 CRANE SPECIFICATIONS

BOOM — 3 Section Full Power Telescope

BOOM LENGTH		NO. OF SECTIONS	FEET OF TELESCOPE	HOOK HEIGHT	
Retracted	Extended			Retracted	Extended
24'	60'	3	36'	28'	62'
*21'	51'	3	30'	25'	53'

Above boom lengths are calculated from center line of fulcrum to center line of sheave pin.

* JIB EXTENSIONS — 17' and 20' lengths.

ELEVATION — Twin double-acting hydraulic cylinders with pilot check valve, 0° to 75°.

BOOM HEAD — 3 sheave.

HOIST (Main and/or *auxiliary) (Cable not included with auxiliary).

MODEL — 40 SECR "equal speed" power up and down, self-contained power pack including hydraulic motor, planetary gear reduction, with automatic "fail safe" brake.

DRUM — 9" diameter.

DRUM CAPACITY — 400' (1/2" cable). Maximum.

SINGLE LINE PULL — 7000 pounds maximum.

SINGLE LINE SPEED — No load — 200 FPM maximum.

* HOIST (Main and/or *auxiliary) (Cable not included with auxiliary).

MODEL — 40 SCR, power up and down, self-contained power pack including hydraulic motor, planetary gear reduction, with automatic "fail safe" brake.

DRUM — 9" diameter

DRUM CAPACITY — 400' (1/2" cable). Maximum.

SINGLE LINE SPEED — No load — Up 200 FPM — Down 700 FPM maximum.

SWING — 360° continuous rotation, ball bearing swing circle.

DRIVE — Gear reducer driven by hydraulic motor; Free swing with foot brake.

GEAR — External.

SPEED — 2.5 RPM

HYDRAULIC PUMPS — Triple pump system totals 118 GPM.

Hydraulic power distribution of three pumps:

[Outrigger — swing — fly telescope] [Mid telescope — boom elevation — *accessory]

[Main Hoist — *auxiliary hoist].

PUMP DRIVE—PTO driven by transmission with disconnect in cab.

CONTROLS—Located in cab.

TYPE—4 way double-acting hydraulic valves with integral main and circuit relief valves.

AXLE WEIGHT DISTRIBUTION

6x4 Drive

6x6 Drive

FRONT 11,300 lbs.

FRONT 11,600 lbs.

REAR 31,000 lbs.

REAR 30,600 lbs.

Axle weight distribution shown above is for the basic machine, and may vary slightly due to manufacturing tolerances or the addition of optional equipment.

WHEELBASE — 169".

FRAME — 12" x 12", Man Ten Steel, "H" Beam.

OUTRIGGERS—Hydraulic double-box, integral with frame; box type totally enclosed vertical jacks and floats; beams extend to 15' wide, retract to 8'. Full hydraulic in, out, up, and down; pilot check valves, steel covers and mechanical pinlocks on vertical jacks. Controls located in cab.

STEERING GEAR — Ross TE-71 cam and lever, roller-mounted, with hydraulic power steering.

ENGINE SPECIFICATIONS

MAKE TYPE	GAS	*DIESEL	*DIESEL
BORE & STROKE	IHC RD-450	GM 4-71N	Cummins C-180
MAXIMUM BHP	6 Cylinder	4 Cyl. O.H.V.	6 Cyl. O.H.V.
MAXIMUM TORQUE	4.375" x 5"	4.25" x 5"	4.4375" x 5"
GOVERNED RPM	182 @ 3000 RPM	175 @ 2300 RPM	180 @ 2500 RPM
ELECTRICAL SYSTEM	388 lbs. ft. @ 1600 RPM	432 lbs. ft. @ 1400 RPM	425 lbs. ft. @ 1700 RPM
	2600 RPM	2100 RPM	2500 RPM
	12 Volt	12 Volt	12 Volt

FUEL CAPACITY — 40 gallon tank, right side of frame.

RADIATOR — 695 sq. in., capacity 32 quarts.

CLUTCH — 14" single plate, dry disc type. Lining Area 202 sq. in.

TRANSMISSION — (6x4) Main: 5 speeds forward, 1 reverse.

Auxiliary: 3 speed.

(6x6) Main: 5 speeds forward, 1 reverse.

Transfer: 2 speed.

UNIVERSAL JOINTS — Needle Bearing type.

*DENOTES OPTIONAL EQUIPMENT

GROVE Hydraulic CRANES

TD150 CRANE SPECIFICATIONS (Continued)

SPRINGS — Front — Alloy steel semi-elliptic with overload. Main — 50" x 3", 7-leaf. Overload — 27" x 3", 5-leaf.

SHOCK ABSORBERS — Front axle only.

REAR SUSPENSION — Tandem axle walking beams, rubber bushed with steel saddles.

BRAKES — Service: Full Air, 6 wheel with 12 cu. ft. compressor. Size: front 16" x 4", rear 16-1/2" x 4". Total lining area 788 sq. in.

Parking: Mechanical, drive line type. 14" diameter two shoe; slack adjustment on hand lever, and valve to actuate service brakes.

TIRES — 9.00 x 20, 10-ply rating; singles front, duals rear, (*10:00 x 20, 12 ply rating optional)

CAB — All steel, one-man-beside-the-engine type, complete with swivel seat (180°) and all crane controls. Safety glass windshield and windows, skylight, rear view mirror, heater and defroster, utility compartment, and adjustable side windows. Instrument panel consisting of: heat indicator, fuel gauge, speedometer, air gauge, and low pressure warning buzzer.

ELECTRICAL SYSTEM — 12-volt starting and lighting, instrument panel light, sealed beam, tilt-ray headlights, tail and stop lights, windshield wiper, horn and turn signals, front and rear ICC clearance lights.

MISCELLANEOUS EQUIPMENT — Wheel nut wrench, channel type front bumper, two front towing loops.

OVERALL SPEEDS AND GRADEABILITY — Using standard tires, transmission, transfer, axles and engine at governed speed:

MODEL 64-15GF (6x4)

GEAR	HIGH RANGE		INTERMEDIATE		LOW RANGE	
	SPEED (MPH)	% GRADEABILITY	SPEED (MPH)	% GRADEABILITY	SPEED (MPH)	% GRADEABILITY
5th	50.7	1.28	38.0	2.2	17.0	6.7
4th	36.0	2.4	27.0	3.7	12.0	10.1
3rd	20.4	5.4	15.3	7.6	6.9	18.9
2nd	11.0	11.3	8.2	15.6	3.7	36.5
1st	6.3	20.8	4.7	28.2	2.1	65.0
Rev.	6.3	20.7	4.7	28.1	2.1	64.5

AXLES — Front — non-driving; Capacity — 12,000 lbs. Rear — hypoid single reduction. Ratio 7.8 to 1; Capacity 32,000 lbs.

MODEL 66-15GF (6x6)

GEAR	HIGH RANGE		LOW RANGE	
	SPEED (MPH)	% GRADEABILITY	SPEED (MPH)	% GRADEABILITY
5th	50.9	1.00	15.6	6.65
4th	39.2	1.74	12.0	9.0
3rd	22.1	4.25	6.8	17.1
2nd	11.8	9.3	3.6	33.7
1st	6.0	19.7	1.85	67.0
Rev.	6.0	19.5	1.86	66.8

AXLES — Front — Hypoid Single Reduction; Capacity 12,000 lbs. Rear — hypoid single reduction; Ratio 7.8 to 1; Capacity 32,000 lbs.

* DENOTES OPTIONAL EQUIPMENT.

Constant improvement and engineering progress makes it necessary that we reserve the right to make specification, equipment and price changes without notice.