

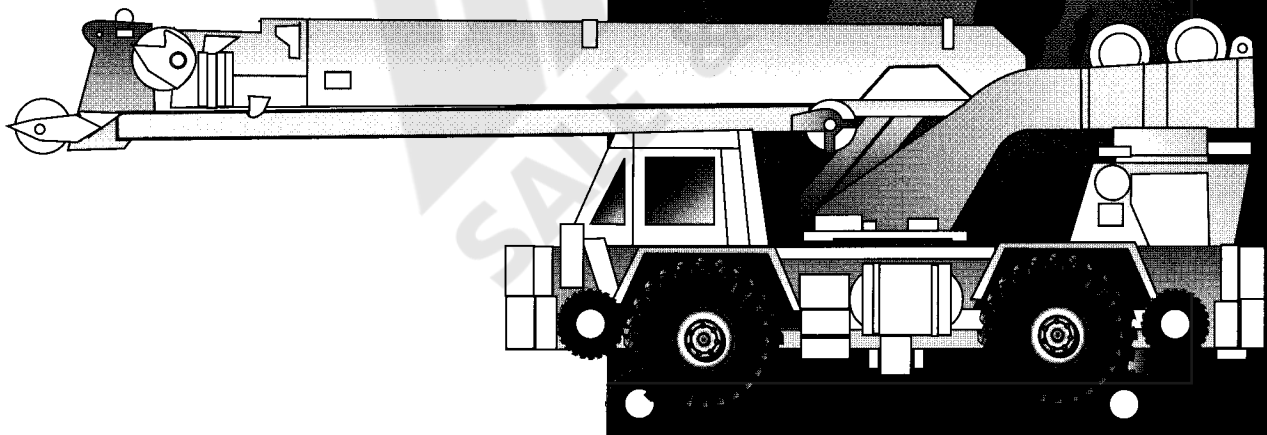

**GROVE**<sup>®</sup>  
**CRANE**

# RTR58D



**Rough Terrain Rail Hydraulic Crane**

# Dimensions

## BOX BEAM

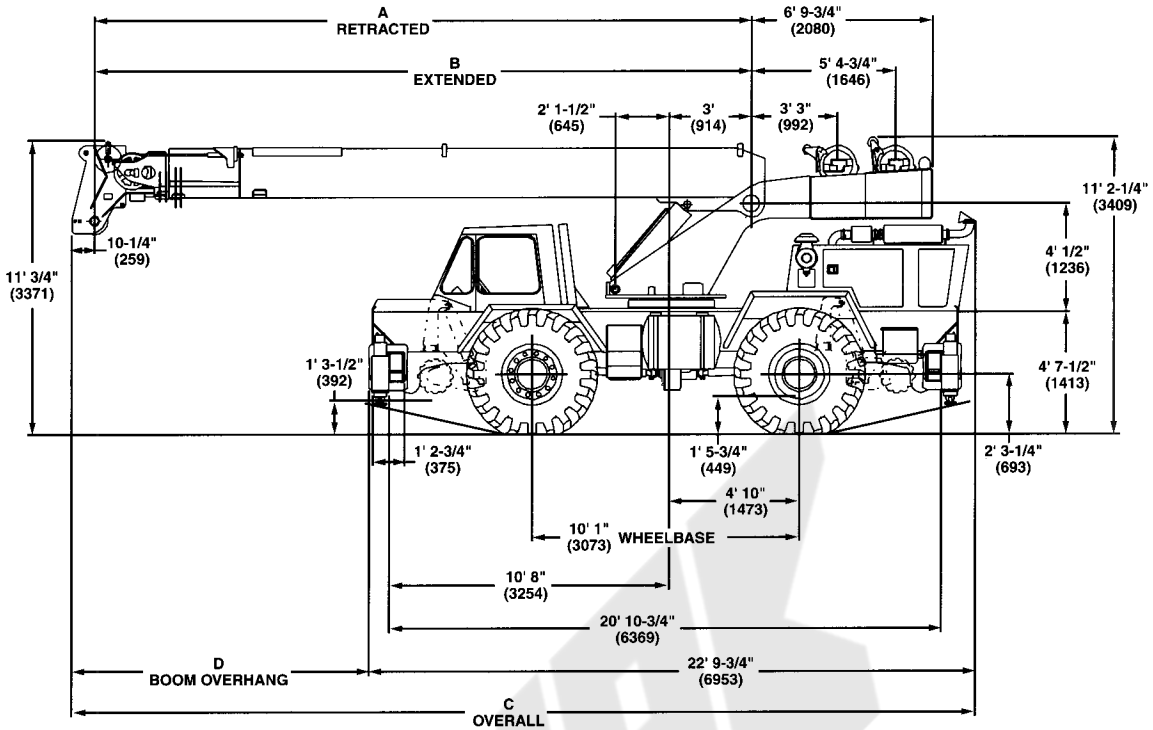

Boom Option	A	B	C	Box Beam D	Cantilever D
24' - 42'	289.5 (7353.3)	498.5 (12 661.9)	400.44 (10 171.2)	126.89 (3217.9)	134.19 (3408.4)
25' - 60'	297 (7543.8)	715.0 (18 161)	407.94 (10 361.7)	134.19 (3408.4)	141.69 (3598.9)

## CANTILEVER

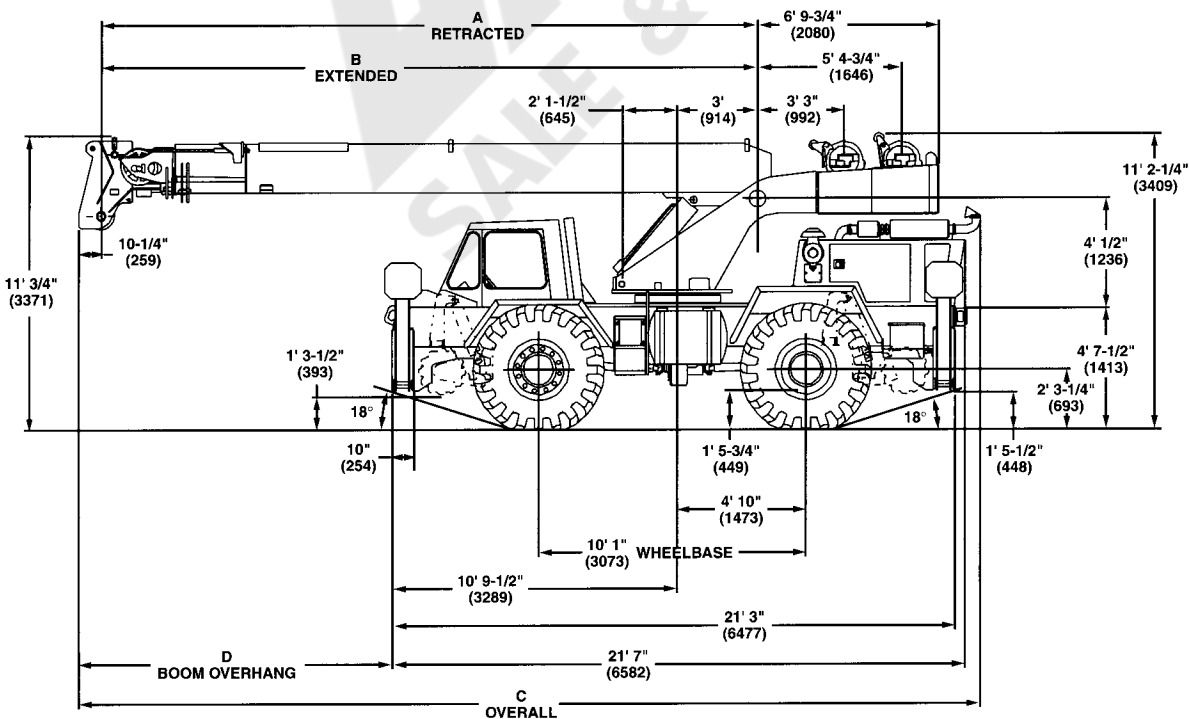

Note: ( ) Reference dimensions in mm

# Working range



25 - 60 ft.  
(7.6 - 18.3 m)

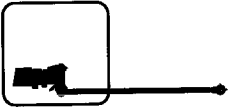

20 ft.  
(6.1 m)



7,470 lbs.  
(3388 kg)

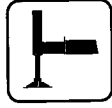

100%



360°

FEET

100

90

80

70

60

50

40

30

20

10

0

80

70

60

50

40

30

20

10

FEET

AXIS OF ROTATION →

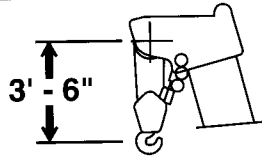
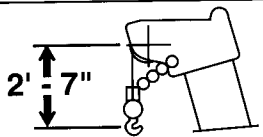
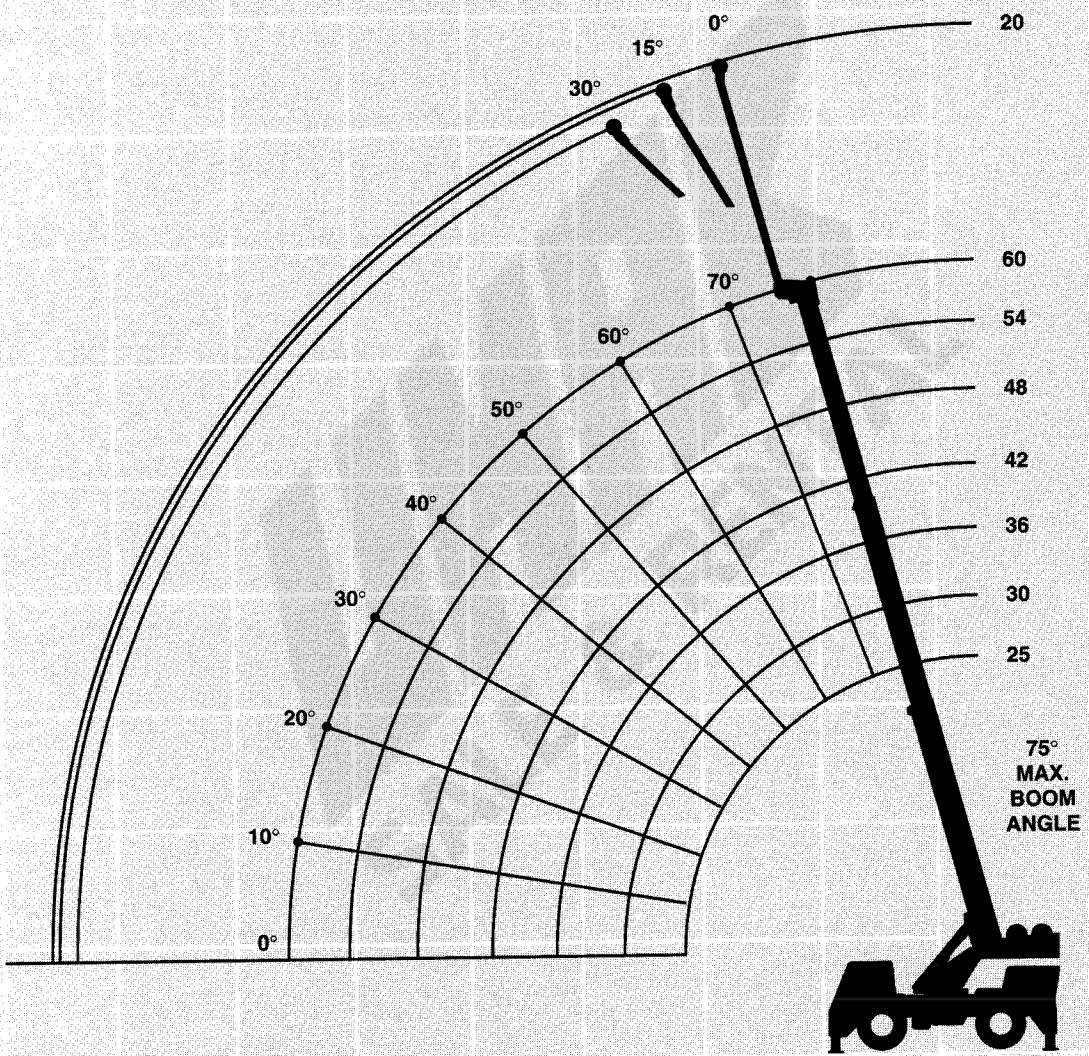

DIMENSIONS ARE FOR LARGEST GROVE FURNISHED HOOK BLOCK AND HEADACHE BALL, WITH ANTI-TWO BLOCK ACTIVATED.

# Superstructure specifications

## Boom

25 ft. - 60 ft. (7.6 m - 18.3 m) three-section, full power boom. Maximum tip height: 66 ft. (20.1 m).

## \*Optional Boom

24 ft. - 42 ft. (7.4 m - 12.7 m) two-section, full power boom. Maximum tip height: 48 ft. (14.6 m).

## \*Optional Jib (60 ft. Boom)

20 ft. (6.1 m) "A-frame" jib offsettable at 0°, 15° or 30°. Stows beneath base boom section. Maximum tip height: 85 ft. (25.9 m).

## Boom Nose

Three steel sheaves mounted on heavy duty tapered roller bearings with removable pin-type rope guards.

\*Optional removable auxiliary boom nose with removable pin-type rope guards.

## Boom Elevation

Two double acting hydraulic cylinders with integral holding valves provide elevation from 0° to 75°.

## Load Moment & Anti-Two Block System

Standard load moment and anti-two block system with audio-visual warning and control lever lockout. These systems provide electronic display of boom angle, length, radius, tip height, relative load moment, maximum permissible load, load indication and warning of impending two-block condition.

Additionally, boom angle, tip height, and swing angle presets with A/V warning are provided. An on track inclinometer provides readout of side-to-side inclination which automatically switches on rail charts.

## Swing

Ball bearing swing circle with 360° continuous rotation. Grove planetary drive with automatic multi-disc swing brake and plunger type 1 position mechanical house-lock. Maximum speed: 2.9 RPM.

## Counterweight

Removable, bolted to turntable mast.

Main only: 7,470 lbs. (3388 kg).

Main & Auxiliary: 5,710 lbs. (2590 kg).

## Hydraulic System

Three main gear pumps with a combined capacity of 112.5 GPM (426 LPM) driven by carrier engine through P.T.O. \*Optional pump disconnect with engine jogging switch.

Three individual valve banks.

Return line type filter with full flow by-pass protection and service indicator. Replaceable cartridge with micron filtration rating of 15/30/38.

88 gallon (333 L) reservoir.

Remote mounted oil cooler with thermostatically controlled electric motor driven fan.

System pressure test ports with quick release type fittings for each circuit.

## Hoist Specifications

### Main and Auxiliary Hoist

Power up and down equal speed, planetary reduction with automatic brake and hoist drum cable followers. Electronic hoist drum rotation indicators.

<u>Make/Model</u>	<u>Main Hoist</u> <u>HO15B-16</u>	<u>*Aux. Hoist</u> <u>HO15B-16</u>
Maximum Bottom layer	340 FPM	184 FPM
Single Line	(104 m/min)	(56 m/min)
Speed:		
Intermediate layer	370 FPM (113 m/min)	200 FPM (61 m/min)
Top layer	399 FPM (122 m/min)	216 FPM (66 m/min)
Maximum Single Line Pull:	9,640 lbs. (4373 kg)	8,653 lbs. (3925 kg)
Intermediate layer	8,861 lbs. (4019 kg)	7,953 lbs. (3607 kg)
Top layer	8,198 lbs. (3719 kg)	7,358 lbs. (3338 kg)
Maximum Permissible Single Line Pull	8,496 lbs. (3854 kg)	
w/5:1 Strength Factor:	5/8 in. (16 mm)	18 x 19 class

## \*Optional Equipment

\*Aux. hoist w/electronic hoist drum rotation indicator & cable follower

\*Dual 360° flashing lights

\*Cab spotlight

\*Worklights - boom mounted

\*Cold start aid (less canister)

\*Tachometer

\*Engine block heater

\*Hot water heater

\*Hookblocks/headache balls

\*Pintle hook front/rear

\*Tow winch (front mounted - maximum pull: 15,000 lbs. [6804 kg]; maximum speed: 72 ft./min. [22 m/min])

\*Spare tire & wheel

\*Tool kit

\*Engine oil pan heater

\*A/V warning system

\*Hydraulic oil cooler

\*Propane cab heater

\*Partial outrigger extension (box beam only)

\*Acoustics - cab

\*360° positive swing lock

*\*Denotes optional equipment*

# Carrier specifications

## Frame

Steel all welded box-type construction with integral outrigger housings and front/rear lifting, towing and tie down lugs.

## Outriggers (Cantilever)

Cantilever arm type with mechanical locks at all four corners with integral check valves on each extension cylinder. Integral all steel outrigger float pads 13.5 in. (343 mm) square.

### \*Outriggers (Box Beam)

Hydraulic single stage telescopic box beam with mechanical locks and jack outriggers with holding valves. All steel fabricated outrigger floats, 18 in. (457 mm) diameter, with stowage.

## Outrigger Controls (Cantilever)

Joystick type hydraulic hand selector control located on right hand console and dash mounted extend/retract lever requires two hand operation. Crane level indicator located in cab.

### \*Outrigger Controls (Box Beam)

Joystick type electrical/hydraulic hand selector control located on right hand console and dash mounted extend/retract lever requires two hand operation. Crane level indicator located in cab.

## Engine

Cummins 6BT 5.9 L six cylinders, turbocharged, water cooled diesel. 130 bhp (97 kW) (Gross) @ 2,700 RPM. Maximum torque: 368 ft. lbs. (499 Nm) @ 1,600 RPM with spark arrestor.

## Fuel Tank Capacity

60 gallons (227 L) with vandal protection.

## Electrical System

Two 12 V - maintenance free batteries. 625 CCA @ 0° F. 24 V starting with battery disconnect switch. 30 AMP breaker for radio.

## Drive

4 x 4 or 4 x 2.

## Steering

Fully independent power steering:

Front: Full hydraulic steering wheel controlled.

Rear: Full hydraulic tiller bar controlled.

Provides infinite variations of 4 main steering modes: front only, rear only, crab and coordinated.

Rear wheel steer alignment indicator.

## Transmission

Remote mounted powershift with 6 speeds forward and 6 reverse, 3 in high range, 3 in low range. Rear axle disconnect for 4 x 2 travel with high transmission temperature A/V warning.

## Axles

Heavy duty axles with frame modification.

Front: Drive/steer with differential and planetary reduction hubs rigid mounted to frame.

Rear: Drive/steer with differential and planetary reduction hubs pivot mounted to frame.

\*Optional: No-spin differential on rear axle.

## Oscillation Lockouts

Automatic full hydraulic lockouts on rear axle permit oscillation only with boom centered over the front.

\*Optional oscillation lockout override control.

## Tires

16.00 x 25 - 28 PR earthmover type, tubeless.

## Brakes

Service brakes, full air dual circuit on all four wheels with standard air dryer. Spring applied parking brake, air released on all 4 wheels.

## Lights

Lighting package including turn indicators, head, tail, brake and hazard warning lights.

## Cab

Steel fabricated frame mounted with tinted safety glass throughout. Deluxe adjustable seat. Complete driving controls and engine instrumentation. Dash mounted control levers for all craning functions. Other standard features include: sliding side doors, horn, circulating air fan, domelight, electric windshield washer/wiper, fire extinguisher and seat belt.

## Maximum Speed

16 MPH (25.7 kph).

## Gradeability (Theoretical)

80% (Based on 58,280 lbs. [26 435 kg] GVW).

## Gross Vehicle Weight & Axle Loads

BASIC STANDARD MACHINE WITH HI-RAIL

Front: 28,320 lbs. (12 845 kg)

Rear: 29,960 lbs. (13 589 kg)

G.V.W.: 58,280 lbs. (26 435 kg)

## Miscellaneous Standard Equipment

Full width steel fenders, electronic back-up alarm, tire inflation kit, hourmeter, amp meter, lubrication chart, air cleaner service indicator.

### \*Optional Rail Equipment

\*Friction drive hi-rail and controls

\*Battery disconnect switch

\*Handrails on fenders

\*Heavy duty tiedowns

\*Draw bar hitches (heavy duty) (not available with pintle hook opt.)

\*Tool box

\*Air horns - front & rear

\*Dry chemical fire extinguisher (20 lbs.)

\*Paint to specification

\*Rear flood lights

\*Extended West Coast mirrors

\*Hydraulic tool circuits

\*Spare tire carrier - rear

\*Front windshield guard

\*Front mounted winch with 5/8 in. x 100 ft. cable

\*Boom point Fairlead roller (main winch only)

\*Auxiliary boom point Fairlead rollers

\*Metal diagram for maintenance on hi-rail

\*Two way selector switch (back-up alarm)

\*Vandalism Protection Kit

\*Mechanical locks for retracted hi-rail

\*Denotes optional equipment



25 - 60 ft.  
(7.6 - 18.3 m)



7,470 lbs.  
(3388 kg)



100%



360°



Pounds

Feet	25	30	36	42	48	54	60
10	40,000 (60)	36,000 (66)	36,000 (70.5)	36,000 (74)			
12	36,000 (54.5)	36,000 (62)	36,000 (67.5)	35,500 (71)	34,500 (74)		
15	30,000 (45)	30,000 (55)	30,000 (62)	30,000 (66.5)	29,350 (70)	28,000 (73)	25,000 (75.5)
20	25,000 (23.5)	25,000 (41.5)	25,000 (52)	24,300 (59)	23,550 (63.5)	22,900 (67.5)	21,500 (70.5)
24		23,000 (27.5)	23,000 (43.5)	23,000 (52)	20,300 (58)	19,800 (62.5)	18,600 (66)
25		19,900 (23)	19,900 (41)	19,800 (50.5)	19,400 (56.5)	19,000 (61.5)	18,000 (65)
30			14,850 (25.5)	14,850 (40.5)	14,850 (49)	14,850 (55)	14,850 (59.5)
35				11,650 (27.5)	11,650 (40)	11,650 (48)	11,650 (53.5)
40					9,420 (28.5)	9,420 (40)	9,420 (47)
45						7,780 (30)	7,780 (39.5)
50						6,520 (13.5)	6,520 (30)
55							5,530 (16.5)

Minimum boom angle (degrees) for indicated length (no load)

0

Maximum boom length (ft.) at 0 degree boom angle (no load)

60

NOTE: ( ) Boom angles are in degrees.

A6-829-012954

Boom Angle	25	30	36	42	48	54	60
0°	17,800 (21.8)	14,200 (27)	11,350 (33)	9,260 (39)	7,310 (45)	5,900 (51)	4,890 (56.6)

NOTE: ( ) Reference radii are in feet.

A6-829-012918



25 - 60 ft.  
(7.6 - 18.3 m)

7,470 lbs.  
(3388 kg)

100%

OVER FRONT



Pounds

Feet	25	30	36	42	48	54	60
10	40,000 (60)	36,000 (66)	36,000 (70.5)	36,000 (74)			
12	36,000 (54.5)	36,000 (62)	36,000 (67.5)	35,500 (71)	34,500 (74)		
15	30,000 (45)	30,000 (55)	30,000 (62)	30,000 (66.5)	29,350 (70)	28,000 (73)	25,000 (75.5)
20	25,000 (23.5)	25,000 (41.5)	25,000 (52)	24,300 (59)	23,550 (63.5)	22,900 (67.5)	21,500 (70.5)
24		23,000 (27.5)	23,000 (43.5)	23,000 (52)	20,300 (58)	19,800 (62.5)	18,600 (66)
25		20,000 (23)	20,000 (41)	19,800 (50.5)	19,400 (56.5)	19,000 (61.5)	18,000 (65)
30			16,000 (25.5)	16,000 (40.5)	16,000 (49)	15,900 (55)	15,400 (59.5)
35				13,300 (27.5)	13,300 (40)	13,300 (48)	13,200 (53.5)
40					11,200 (28.5)	11,200 (40)	11,200 (47)
45						9,600 (30)	9,600 (39.5)
50						8,000 (13.5)	8,000 (30)
55							6,900 (16.5)

Minimum boom angle (degrees) for indicated length (no load)

0

Maximum boom length (ft.) at 0 degree boom angle (no load)

60

NOTE: ( ) Boom angles are in degrees.

A6-829-012955

Boom Angle	25	30	36	42	48	54	60
0°	17,800 (21.8)	14,200 (27)	11,350 (33)	9,260 (39)	7,310 (45)	5,900 (51)	4,890 (56.6)

NOTE: ( ) Reference radii are in feet.

A6-829-012918



25 - 60 ft.  
(7.6 - 18.3 m)



7,470 lbs.  
(3388 kg)



Stationary  
16.00 x 25 (28PR) Tires



360°



Pounds

Feet	25	30	36	42	48	54
10	25,350 (60)					
12	19,250 (54.5)					
15	13,450 (45)	11,550 (55)	11,550 (62)	11,550 (66.5)	11,550 (70)	
20	8,500 (23.5)	8,480 (41.5)	8,480 (52)	8,480 (59)	8,480 (63.5)	8,480 (67.5)
25		5,880 (23)	5,880 (41)	5,880 (50.5)	5,880 (56.5)	5,880 (61.5)
30			4,260 (25.5)	4,260 (40.5)	4,260 (49)	4,260 (55)
35				3,160 (27.5)	3,160 (40)	3,160 (48)
40					2,360 (28.5)	2,360 (40)
45						1,760 (30)

NOTE: ( ) Boom angles are in degrees.

A6-829-012916

Boom Angle	25	30	36	42	48	54
0°	7,390 (21.8)	5,150 (27)	3,560 (33)	2,500 (39)	1,760 (45)	1,200 (51)

NOTE: ( ) Reference radii are in feet.

A6-829-012918





25 - 60 ft.  
(7.6 - 18.3 m)

7,470 lbs.  
(3388 kg)

Stationary  
16.00 x 25 (28PR) Tires

Defined Arc  
Over Front



Pounds

Feet	25	30	36	42	48	54	60
10	29,900 (60)						
12	26,200 (54.5)						
15	21,850 (45)	13,550 (55)	13,550 (62)	13,550 (66.5)	13,550 (70)		
20	13,550 (23.5)	10,900 (41.5)	10,900 (52)	10,700 (59)	10,700 (63.5)	10,700 (67.5)	
25		9,660 (23)	9,660 (41)	8,860 (50.5)	8,860 (56.5)	8,860 (61.5)	8,860 (65)
30			7,140 (25.5)	6,960 (40.5)	6,960 (49)	6,960 (55)	6,960 (59.5)
35				5,480 (27.5)	5,480 (40)	5,480 (48)	5,480 (53.5)
40					4,290 (28.5)	4,290 (40)	4,290 (47)
45						3,400 (30)	3,400 (39.5)
50						2,710 (13.5)	2,710 (30)
55							2,160 (16.5)

NOTE: ( ) Boom angles are in degrees.

A6-829-012915

Boom Angle	25	30	36	42	48	54	60
0°	11,300 (21.8)	8,510 (27)	6,070 (33)	4,500 (39)	3,400 (45)	2,590 (51)	2,010 (56.6)

NOTE: ( ) Reference radii are in feet.

A6-829-012918



25 - 60 ft.  
(7.6 - 18.3 m)



7,470 lbs.  
(3388 kg)



Pick & Carry Capacities  
Up to 2.5 MPH  
16.00 x 25 (28PR) Tires



Boom Centered  
Over Front



Feet	25	30	36	42	48	54	60
10	30,600 (60)						
12	25,900 (54.5)						
15	20,600 (45)	13,800 (55)	13,800 (62)	13,800 (66.5)	13,800 (70)		
20	13,500 (23.5)	12,800 (41.5)	12,800 (52)	10,050 (59)	10,050 (63.5)	10,050 (67.5)	
25		9,660 (23)	9,660 (41)	8,260 (50.5)	8,260 (56.5)	8,260 (61.5)	8,260 (65)
30			7,140 (25.5)	6,480 (40.5)	6,480 (49)	6,480 (55)	6,480 (59.5)
35				5,480 (27.5)	5,310 (40)	5,310 (48)	5,310 (53.5)
40					4,290 (28.5)	4,290 (40)	4,290 (47)
45						3,400 (30)	3,400 (39.5)
50						2,710 (13.5)	2,710 (30)
55							2,160 (16.5)

NOTE: ( ) Boom angles are in degrees.

A6-829-012917

Boom Angle	25	30	36	42	48	54	60
0°	11,300 (21.8)	8,400 (27)	6,070 (33)	4,500 (39)	3,400 (45)	2,590 (51)	2,010 (56.6)

NOTE: ( ) Reference radii are in feet.



25 - 60 ft.  
(7.6 - 18.3 m)



7,470 lbs.  
(3388 kg)



Pick & Carry  
Up to 2.5 MPH



15° Defined Arc Over Front  
(Laying Rail)  
Up to 3° Side Slope



Pounds

Feet	36	38	40	42
30	8,490 (25)			
32	8,490 (15)	8,490 (24.5)		
34		8,490 (15)	8,490 (24)	
36			8,490 (14.5)	8,490 (22)
38				8,490 (11)

NOTE: ( ) Boom angles are in degrees.

0° Boom Angle on Rail - Pick & Carry Over Front

Boom Angle	36	38	40	42
0°	8,490 (33)	8,490 (35)	6,840 (37)	6,140 (38.6)

NOTE: ( ) Reference radii in feet.

A6-829-012126B



25 - 60 ft.  
(7.6 - 18.3 m)



7,470 lbs.  
(3388 kg)



Pick & Carry  
Up to 2.5 MPH



15° Defined Arc Over Front  
(Laying Rail)  
3° to 6° Side Slope



Pounds

Feet	36	38	40	42
30	5,590 (25)			
32	4,740 (15)	4,740 (24.5)		
34		4,190 (15)	4,190 (24)	
36			3,790 (14.5)	3,790 (22)
38				3,460 (11)

NOTE: ( ) Boom angles are in degrees.

0° Boom Angle on Rail - Pick & Carry Over Front

Boom Angle	36	38	40	42
0°	4,420 (33)	3,970 (35)	3,620 (37)	3,390 (38.6)

NOTE: ( ) Reference radii in feet.

A6-829-012912A

# Working range



24 - 42 ft.  
(7.3 - 12.8 m)

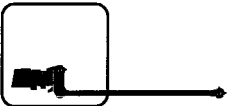

20 ft.  
(6.1 m)



7,470 lbs.  
(3388 kg)

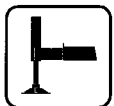

100%



360°

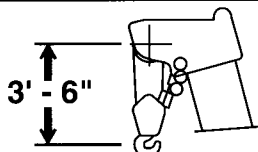
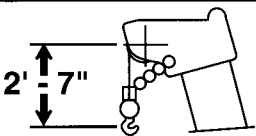
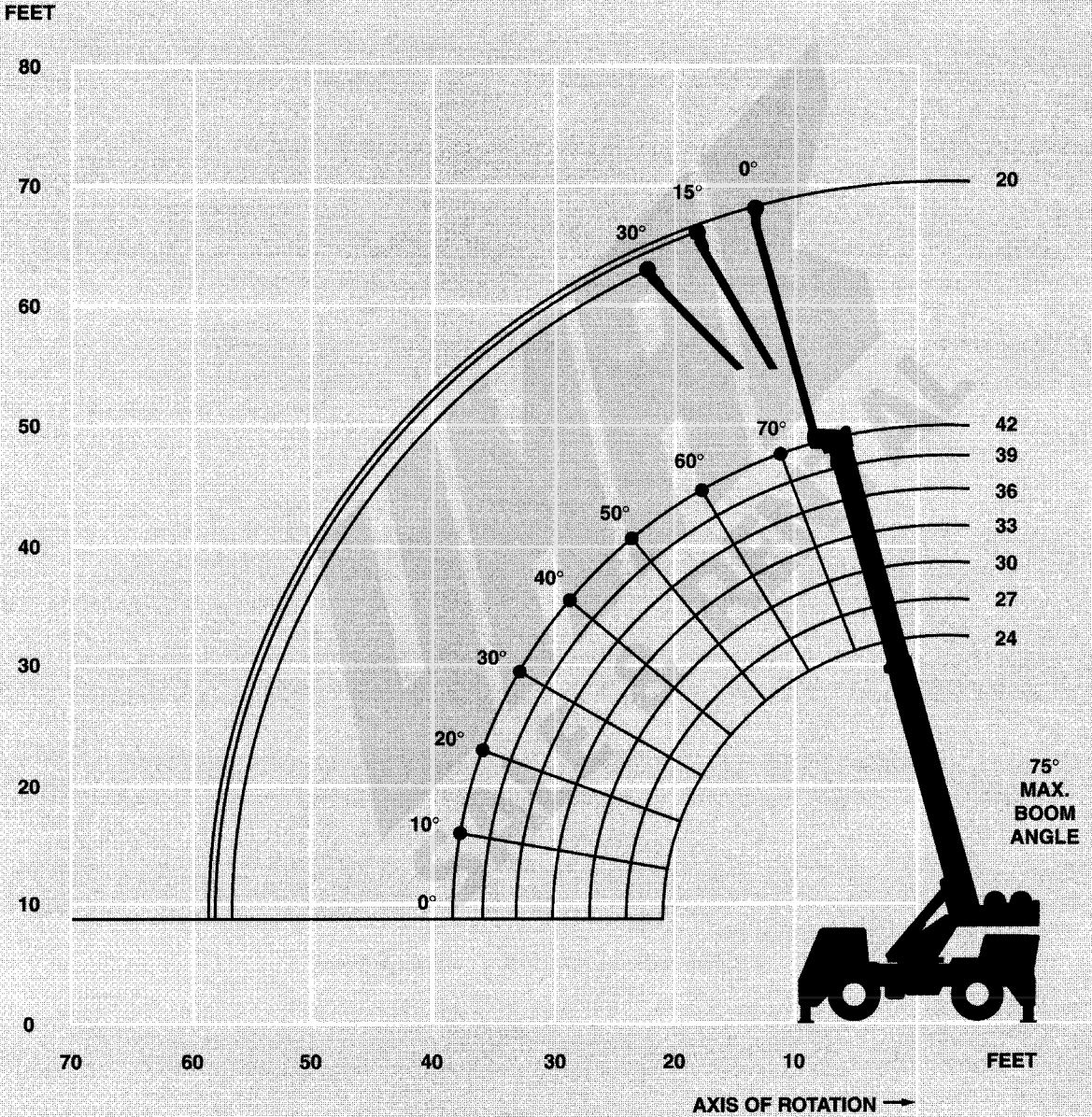

**DIMENSIONS ARE FOR LARGEST GROVE FURNISHED HOOK BLOCK AND HEADACHE BALL, WITH ANTI-TWO BLOCK ACTIVATED.**



24 - 42 ft.  
(7.4 - 12.7 m)

7,470 lbs.  
(3388 kg)

100%

360°



Pounds

Feet	24	27	30	33	36	39	42
10	40,000 (59.5)	40,000 (63)	40,000 (66)	40,000 (68.5)	40,000 (70.5)	40,000 (72)	36,000 (73.5)
12	35,800 (54)	35,800 (58)	35,800 (61.5)	35,800 (64.5)	35,800 (67)	35,450 (69)	35,000 (70.5)
15	29,300 (44)	29,300 (50)	29,300 (54.5)	29,300 (58.5)	29,300 (61.5)	29,300 (64)	29,300 (66)
20	23,300 (20)	23,300 (33)	23,300 (41.5)	23,300 (47.5)	23,300 (52)	23,200 (55.5)	23,000 (58)
25			18,400 (22.5)	18,400 (33.5)	18,400 (40.5)	18,400 (46)	18,400 (49.5)
30					14,900 (25)	14,900 (34)	14,900 (39)
35						12,500 (14.5)	12,500 (25.5)

Minimum boom angle (deg.) for indicated length (no load)

0

Maximum boom length (ft.) at 0 deg. boom angle (no load)

42

NOTE: ( ) Boom angles are in degrees.

A6-829-014123

Boom Angle	24	27	30	33	36	39	42
0°	19,600 (21.1)	17,200 (24)	15,250 (27)	13,650 (30)	12,300 (33)	11,150 (36)	10,300 (38.6)

NOTE: ( ) Reference radii are in feet.



24 - 42 ft.  
(7.4 - 12.7 m)

7,470 lbs.  
(3388 kg)

Stationary  
16.00R25 Tires

360°



Pounds

Feet	24	27	30	33	36	39	42
10	23,950 (59.5)	23,950 (63)	23,950 (66)	23,950 (68.5)	23,950 (70.5)	23,950 (72)	23,950 (73.5)
12	20,150 (54)	20,150 (58)	20,150 (61.5)	20,150 (64.5)	20,150 (67)	20,150 (69)	20,150 (70.5)
15	16,250 (44)	16,250 (50)	16,250 (54.5)	16,250 (58.5)	16,250 (61.5)	16,250 (64)	16,250 (66)
20	11,050 (20)	11,050 (33)	11,050 (41.5)	11,050 (47.5)	11,050 (52)	11,050 (55.5)	11,050 (58)
25			8,010 (22.5)	8,010 (33.5)	8,010 (40.5)	8,010 (46)	8,010 (49.5)
30				6,040 (2.5)	6,040 (25)	6,040 (34)	6,040 (39)
35						4,840 (14.5)	4,840 (25.5)

NOTE: ( ) Boom angles are in degrees.

A6-829-014124

Boom Angle	24	27	30	33	36	39	42
0°	10,050 (21.1)	8,570 (24)	7,080 (27)	6,040 (30)	5,260 (33)	4,660 (36)	4,250 (386)

NOTE: ( ) Reference radii are in feet.

A6-829-014127



24 - 42 ft.  
(7.4 - 12.7 m)

7,470 lbs.  
(3388 kg)

Stationary  
16.00R25 Tires

Defined Arc  
Over Front



Pounds

Feet	24	27	30	33	36	39	42
10	26,800 (59.5)	26,800 (63)	26,800 (66)	26,800 (68.5)	26,800 (70.5)	26,800 (72)	26,800 (73.5)
12	23,850 (54)	23,850 (58)	23,850 (61.5)	23,850 (64.5)	23,850 (67)	23,850 (69)	23,850 (70.5)
15	19,850 (44)	19,850 (50)	19,850 (54.5)	19,850 (58.5)	19,850 (61.5)	19,850 (64)	19,850 (66)
20	15,250 (20)	15,250 (33)	15,250 (41.5)	15,250 (47.5)	15,250 (52)	15,250 (55.5)	15,250 (58)
25			12,150 (22.5)	12,150 (33.5)	12,150 (40.5)	12,150 (46)	12,150 (49.5)
30				9,420 (2.5)	9,420 (25)	9,420 (34)	9,420 (39)
35						7,500 (14.5)	7,500 (25.5)

NOTE: ( ) Boom angles are in degrees.

A6-829-014125

Boom Angle	24	27	30	33	36	39	42
0°	14,450 (21.1)	12,700 (24)	11,000 (27)	9,420 (30)	8,180 (33)	7,190 (36)	6,500 (38.6)

NOTE: ( ) Reference radii are in feet.

A6-829-014127



24 - 42 ft.  
(7.4 - 12.7 m)



7,470 lbs.  
(3388 kg)



Pick & Carry Capacities  
Up to 2.5 MPH  
16.00R25 Tires



Boom Centered  
Over Front



Pounds

Feet	24	27	30	33	36	39	42
10	37,500 (59.5)	37,500 (63)	37,500 (66)	37,500 (68.5)	37,500 (70.5)	37,500 (72)	37,500 (73.5)
12	32,250 (54)	32,250 (58)	32,250 (61.5)	32,250 (64.5)	32,250 (67)	32,250 (69)	32,250 (70.5)
15	26,350 (44)	26,350 (50)	26,350 (54.5)	26,350 (58.5)	26,350 (61.5)	26,350 (64)	26,350 (66)
20	17,100 (20)	17,100 (33)	17,100 (41.5)	17,100 (47.5)	17,100 (52)	17,100 (55.5)	17,100 (58)
25			10,050 (22.5)	10,050 (33.5)	10,050 (40.5)	10,050 (46)	10,050 (49.5)
30				8,190 (2.5)	8,190 (25)	8,190 (34)	8,190 (39)
35						6,820 (14.5)	6,820 (25.5)

NOTE: ( ) Boom angles are in degrees.

A6-829-014126

Boom Angle	24	27	30	33	36	39	42
0°	11,650 (21.1)	10,550 (24)	9,240 (27)	8,190 (30)	7,320 (33)	6,600 (36)	6,060 (38.6)

NOTE: ( ) Reference radii are in feet.

A6-829-014127



24 - 42 ft.  
(7.4 - 12.7 m)



7,470 lbs.  
(3388 kg)



Pick & Carry  
Up to 2.5 MPH



15° Defined Arc Over Front  
(Laying Rail)  
Up to 3° Side Slope



Pounds

Feet	36	38	40	42
30	8,490 (25)			
32	8,490 (15)	8,490 (24.5)		
34		8,490 (15)	8,490 (24)	
36			8,490 (14.5)	8,490 (22)
38				8,490 (11)

NOTE: ( ) Boom angles are in degrees.

0° Boom Angle on Rail - Pick & Carry Over Front

Boom Angle	36	38	40	42
0°	8,490 (33)	8,490 (35)	7,320 (37)	6,800 (38.6)

NOTE: ( ) Reference radii in feet.



24 - 42 ft.  
(7.4 - 12.7 m)

7,470 lbs.  
(3388 kg)

Pick & Carry  
Up to 2.5 MPH

15° Defined Arc Over Front  
(Laying Rail)  
3° to 6° Side Slope



Pounds

Feet	36	38	40	42
30	6,300 (25)			
32	5,460 (15)	5,460 (24.5)		
34		4,900 (15)	4,900 (24)	
36			4,490 (14.5)	4,490 (22)
38				4,180 (11)

NOTE: ( ) Boom angles are in degrees.

0° Boom Angle on Rail - Pick & Carry Over Front

Boom Angle	36	38	40	42
0°	5,150 (33)	4,680 (35)	4,320 (37)	4,100 (38.6)

NOTE: ( ) Reference radii in feet.

A8-829-012376

THIS CHART IS ONLY A GUIDE AND SHOULD NOT BE USED TO OPERATE THE CRANE. The individual crane's load chart, operating instructions and other instructional plates must be read and understood prior to operating the crane.

## Lifting Area Diagram

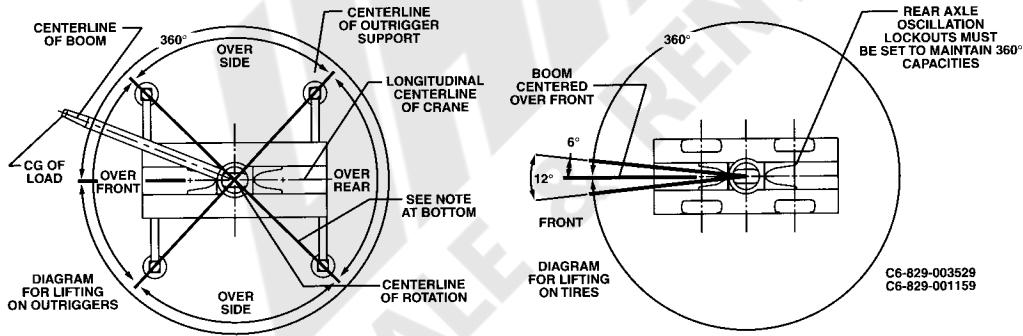

BOLD LINES DETERMINE THE LIMITING POSITION OF ANY LOAD FOR OPERATION WITHIN WORKING AREAS INDICATED

WORKING AREA DIAGRAM

## Weight Reductions for Load Handling Devices

Auxiliary Boom Head

100 lbs. (45.4 kg)

Hookblocks and Headache Balls:

12 Ton, 1 Sheave

268 lbs.+ (121.6 kg)+

15 Ton, 2 Sheave

290 lbs.+ (131.5 kg)+

22 Ton, 3 Sheave

455 lbs.+ (206.4 kg)+

5 Ton Headache Ball

172 lbs.+ (78 kg)+

Fairlead Assembly (Main)

250 lbs. (113.4 kg)

Fairlead Assembly (Aux.)

160 lbs. (72.6 kg)

+Refer to rating plate for actual weight



# Rated lifting capacities

## NOTES FOR LIFTING CAPACITIES

**WARNING: THIS CHART IS ONLY A GUIDE.**  
 The notes below are for illustration only and should not be relied upon to operate the crane. The individual crane's load chart, operating instructions and other instruction plates must be read and understood prior to operating the crane.

1. All rated loads meet ANSI/ASME B30.5, Mobile and Locomotive Cranes. Testing and development were performed to SAEJ1063, Cantilevered Boom Crane Structures - Method of Test, and SAEJ765 Crane Stability Test Code.

2. Capacities are applicable to machines equipped with 16.00 x 25 (28 ply) bias ply tires, at 109 psi cold inflation pressure or 16.00R25 \*\* xnp radial tire, at 115 psi cold inflation pressure.

3. Defined Arc - Over front includes +/-6° on either side of longitudinal centerline of machine.

4. Capacities appearing above the bold line are based on structural strength. Tipping should not be relied upon as a capacity indication.

5. Capacities are applicable only with the machine on a firm level surface.

































6. On rail lifting with jib not permitted.

7. For pick and carry operation, boom must be centered over front of machine, mechanical swing lock engaged and load restrained from swinging. When handling loads in the structural range with capacities close to maximum ratings, travel should be reduced to creep speeds.

8. Lifting loads at close radii directly over the operator's compartment is not recommended.

9. Creep - not over 200 ft. of movement in any 30 minute period and not exceeding 1 mph.

# Symbols Glossary

	Frame		Steering
	Outriggers		Transmission
	Outrigger Controls		Axles
	Engine		Brakes
	Fuel Tank Capacity		Rails
	Electrical System		Suspension
	Drive		Rotation
	Lights		Boom Elevation
	Cab		Swing
	Boom		Counterweight
	Fixed Swingaway		Oil
	Tele-Swingaway		Hydraulic System
	Jib		Hoist
	Boom Nose		Radius
	Boom Extension		Boom Length
	Speed		Hookblock
	Grade		Gear
	Lattice Extension		Luffing Jib



**GROVE**<sup>®</sup>  
worldwide

**Grove Worldwide – World Headquarters**

**Grove U.S. L.L.C.**  
1565 Buchanan Trail East  
P.O. Box 21  
Shady Grove, Pennsylvania 17256, U.S.A.  
Tel: [Int + 1] (717) 597-8121  
Fax: [Int + 1] (717) 597-4062  
Western Hemisphere, Asia/Pacific

**Grove Europe Limited\***

Sunderland SR4 6TT, England  
Tel: [Int + 44] 191 565-6281  
Fax: [Int + 44] 191 564-0442  
Europe, Africa, Middle East

**Grove Europe Limited\***

Telford Road  
Bicester  
Oxon OX6 0TZ  
Tel: [Int + 44] 1869-878890  
Fax: [Int + 44] 1869-878888

\*Grove Europe Limited, Registered in England,  
Number 1845128, Registered office, Crown Works,  
Pallion, Sunderland, Tyne & Wear, England SR4 6TT

**Deutsche Grove GmbH  
Sales and Service**

Helmholtzstrasse 12, Postfach 5026  
D-40764 Langenfeld, Germany  
Tel: [Int + 49] (2173) 8909-0  
Fax: [Int + 49] (2173) 8909-30

**Wilhelmshaven Works**

Industriegelände West, Postfach 1853  
D-22940 Wilhelmshaven, Germany  
Tel: [Int + 49] (4421) 294-443  
Fax: [Int + 49] (4421) 294-273

**Grove France S.A.**

16, chaussée Jules-César, 95520 OSNY  
B.P. 203, 95523 CERGY PONTOISE CEDEX  
France  
Tel: [Int + 33] (1) 30313150  
Int: [Int + 33] (1) 30386085

**Grove Asia/Pacific - Regional Office**

171 Chin Swee Road  
#06-01 San Centre  
Singapore 169877  
Tel: [Int + 65] 536-6112  
Fax: [Int + 65] 536-6119  
Asia/Pacific, Near East

**Grove China - Representative Office**

Room 713, Towercrest Plaza  
No. 3 Mai Zi Dian West Road  
Chao Yang District  
Beijing, China 100016  
Tel: [Int + 86] (10) 64671690  
Fax: [Int + 86] (10) 64671691

**Grove Product Support**

Western Hemisphere, Asia/Pacific  
1086 Wayne Avenue  
Chambersburg, Pennsylvania USA  
Tel: [Int + 1] (717) 263-5100  
Fax: [Int + 1] (717) 267-0404

Europe, Africa, Middle East  
Sunderland SR4 6TT, England  
Tel: [Int + 44] 191 565-6281  
Parts Fax: [Int + 44] 191 515-7475  
Service Fax: [Int + 44] 191 515-7340

<http://www.groveworldwide.com>

Constant improvement and engineering progress make it necessary that we reserve the right to make specification, equipment, and price changes without notice. Illustrations shown may include optional equipment and accessories and may not include all standard equipment.

Distributed By: