



LOAD CHARTS RT740B

**85% STABILITY
ON OUTRIGGERS**

**75% STABILITY
ON RUBBER**

74062

SERIAL NUMBER

NOTES FOR LIFTING CAPACITIES

GENERAL:

1. Rated loads as shown on lift chart pertain to this machine as originally manufactured and equipped. Modifications to the machine or use of optional equipment other than that specified can result in a reduction of capacity.
2. Construction equipment can be hazardous if improperly operated or maintained. Operation and maintenance of this machine shall be in compliance with the information in the operator's parts and safety manual supplied with this machine. If these manuals are missing, order replacements from the manufacturer through the distributor.
3. The operator and other personnel associated with machine shall fully acquaint themselves with the latest American National Standards Institute (ANSI) Safety Standards for cranes.

SETUP:

1. The machine shall be leveled on a firm supporting surface. Depending on the nature of the supporting surface, it may be necessary to have structural supports under the outrigger floats or tires to spread the load to a larger bearing surface.
2. For outrigger operation, outriggers shall be fully extended with tires raised free of crane weight before operating the boom or lifting loads.
3. If machine is equipped with front jack cylinder, the front jack cylinder shall be set in accordance with written procedure.
4. When equipped with extendable counterweight, the counterweight shall be fully extended before operation.
5. Tires shall be inflated to the recommended pressure before lifting on rubber.
6. With certain boom and hoist tackle combinations, maximum capacities may not be obtainable with standard cable lengths.
7. Do not travel with crane boom extension or jib erected.

OPERATION:

1. Rated loads at rated radius shall not be exceeded. Do not tip the machine to determine allowable loads. For clamshell or concrete bucket operation, weight of bucket and load must not exceed 80% of rated lifting capacities.
2. All rated loads have been tested to and meet minimum requirements of SAE J1063 OCT80 - Cantilevered Boom Crane Structures - Method of Test, and do not exceed 85% of the tipping load on outriggers as determined by SAE J765 OCT80 Crane Stability Test Code.
3. Rated loads include the weight of hook block, slings and auxiliary lifting devices and their weights shall be subtracted from the listed rating to obtain the net load to be lifted. When more than the minimum required hoist reeving is used, the additional rope weight shall be considered part of the load to be handled.
4. Load ratings are based on freely suspended loads. No attempt shall be made to move a load horizontally on the ground in any direction.
5. Rated loads do not account for wind on lifted load or boom. It is recommended when wind velocity is above 20 mph (32km/h), rated loads and boom lengths shall be appropriately reduced.
6. Rated loads are for lift crane service only.
7. Do not operate at a radius or boom length where capacities are not listed. At these positions, the machine may overturn without any load on the hook.
8. The maximum load which can be telescoped is not definable because of variations in loadings and crane maintenance, but it is safe to attempt retraction and extension within the limits of the capacity chart.
9. When either boom length or radius or both are between values listed, the smallest load shown at either the next larger radius or boom length shall be used.
10. For safe operation, the user shall make due allowances for his particular job conditions, such as: soft or uneven ground, out of level conditions, high winds, side loads, pendulum action, jerking or sudden stopping of loads, hazardous conditions, experience of personnel, two machine lifts, traveling with loads, electric wires, etc. Side pull on boom or jib is extremely dangerous.
11. If machine is equipped with individually controlled powered boom sections, the boom sections must be extended equally at all times.
12. Handling of personnel from the boom is not authorized except with equipment furnished and installed by Grove Manufacturing Company.
13. Keep load handling devices a minimum of 18 inches (45.7 cm) below boom head at all times.
14. The boom angle before loading should be greater than the loaded boom angle to account for deflection.
15. Capacities appearing above the bold line are based on structural strength and tipping should not be relied upon as a capacity limitation.
16. Capacities for the 35 ft. (10.6 m) boom length shall be lifted with boom fully retracted. If boom is not fully retracted, capacities shall not exceed those shown for the 40 ft. (12.2 m) boom length.

DEFINITIONS:

1. Operating Radius: Horizontal distance from a projection of the axis of rotation to the supporting surface before loading to the center of the vertical hoist line or tackle with load applied.
2. Loaded Boom Angle (Shown in Parenthesis on Main Boom Capacity Chart): is the angle between the boom base section and the horizontal, after lifting the rated load at the rated radius with the rated boom length.
3. Working Area: Areas measured in a circular arc about the center line of rotation as shown on the working area diagram.
4. Freely Suspended Load: Load hanging free with no direct external force applied except by the lift cable.
5. Side Load: Horizontal force applied to the lifted load either on the ground or in the air.

ON RUBBER CAPACITIES WITH 23.5 x 25 TIRES

STATIONARY CAPACITIES - 360°

Radius in Feet	#05							
	Main Boom Length in Feet							
	35	40	50	*60	70	80	90	100
10	33,000 (66)	31,100 (69.5)	22,150 (74)					
12	27,350 (62)	26,250 (66)	19,000 (71.5)	18,300 (75)				
15	21,300 (56)	21,300 (61)	16,000 (67.5)	15,500 (71.5)	13,250 (74.5)	6,170 (77)		
20	13,150 (44.5)	12,750 (52)	12,400 (61)	12,400 (66.5)	10,300 (70.5)	6,170 (73.5)	4,500 (75.5)	2,050 (77.5)
25	8,630 (28.5)	8,230 (41.5)	7,840 (54)	7,790 (61)	7,850 (66)	6,170 (69.5)	4,500 (72)	2,050 (74.5)
30		5,410 (27)	5,000 (46)	4,870 (55)	5,410 (61)	5,200 (65.5)	4,500 (68.5)	2,050 (71.5)
35			3,100 (36.5)	2,870 (49)	3,380 (56)	3,380 (61.5)	3,120 (65)	2,050 (68)
40			1,650 (24)	1,430 (41.5)	1,750 (50.5)	1,750 (57)	1,710 (61.5)	1,710 (65)

STATIONARY CAPACITIES - DEFINED ARC OVER FRONT (SEE NOTE 3)

Radius in Feet	#05							
	Main Boom Length in Feet							
	35	40	50	*60	70	80	90	100
10	37,300 (66)	31,100 (69.5)	22,150 (74)					
12	32,700 (62)	26,250 (66)	20,000 (71.5)	18,300 (75)				
15	27,500 (56)	23,000 (61)	18,300 (67.5)	16,950 (71.5)	13,250 (74.5)	12,000 (77)		
20	21,550 (44.5)	20,750 (52)	16,950 (61)	13,500 (66.5)	11,400 (70.5)	10,300 (73.5)	9,050 (75.5)	7,350 (77.5)
25	16,950 (28.5)	16,950 (41.5)	13,600 (54)	11,300 (61)	10,250 (66)	9,250 (69.5)	8,050 (72)	6,500 (74.5)
30		11,850 (27)	11,400 (46)	10,000 (55)	9,300 (61)	8,500 (65.5)	7,350 (68.5)	5,900 (71.5)
35			8,220 (36.5)	7,910 (49)	8,430 (56)	7,800 (61.5)	6,850 (65)	5,600 (68)
40			5,910 (24)	5,680 (41.5)	5,980 (50.5)	5,980 (57)	5,980 (61.5)	5,300 (65)
45				4,030 (33)	4,170 (45)	4,170 (52.5)	4,170 (57.5)	4,170 (61.5)
50				2,760 (21.5)	2,770 (38.5)	2,770 (47.5)	2,770 (53.5)	2,770 (58.5)
55					1,840 (31)	1,840 (42)	1,840 (49.5)	1,840 (54.5)
60					1,290 (20)	1,290 (36)	1,290 (45)	1,290 (51)

A6-829-009206 & -009205

RATED LIFTING CAPACITIES IN POUNDS

35 ft. - 110 ft. BOOM

ON OUTRIGGERS - 360°

Radius in Feet	#01								
	Main Boom Length in Feet								
	35	40	50	*60	70	80	90	100	110
10	80,000 (66)	68,000 (69.5)	58,100 (74)						
12	67,400 (62)	62,700 (66)	53,700 (71.5)	44,600 (75)					
15	56,500 (56)	54,500 (61)	48,050 (67.5)	41,550 (71.5)	35,600 (74.5)	33,000 (77)			
20	44,000 (44.5)	43,000 (52)	39,400 (61)	33,550 (66.5)	30,500 (70.5)	28,000 (73.5)	25,500 (75.5)	22,150 (77.5)	
25	33,500 (28.5)	33,000 (41.5)	32,400 (54)	27,750 (61)	25,200 (66)	23,800 (69.5)	21,950 (72)	20,400 (74.5)	18,500 (76)
30		26,500 (27)	25,500 (46)	23,300 (55)	21,050 (61)	20,400 (65.5)	19,300 (68.5)	17,550 (71.5)	15,750 (73.5)
35			20,300 (36.5)	20,000 (49)	17,950 (56)	17,400 (61.5)	16,400 (65)	15,050 (68)	13,650 (70.5)
40	See Warning		16,000 (24)	15,850 (41.5)	15,500 (50.5)	15,050 (57)	14,100 (61.5)	13,100 (65)	12,000 (68)
45	Note 16			12,250 (33)	13,000 (45)	13,000 (52.5)	12,300 (57.5)	11,450 (61.5)	10,600 (65)
50				9,720 (21.5)	10,350 (38.5)	10,750 (47.5)	10,800 (53.5)	10,000 (58.5)	9,500 (62)
55					8,300 (31)	8,770 (42)	9,170 (49.5)	8,830 (54.5)	8,370 (58.5)
60					6,650 (20)	7,150 (36)	7,850 (45)	7,840 (51)	7,410 (55.5)
65						5,830 (29)	6,340 (40)	6,820 (47)	6,590 (52)
70						4,740 (19)	5,100 (34)	5,590 (42.5)	5,880 (48.5)
75							4,050 (27.5)	4,540 (38)	4,980 (45)
80							3,160 (18)	3,650 (32.5)	4,120 (40.5)
85								2,870 (26)	3,380 (36)
90								2,190 (17)	2,740 (31)
95									2,170 (25)
100									1,790 (16)
Minimum boom angle (deg.) for indicated length (no load)									0
Maximum boom length (ft.) at 0 deg. boom angle (no load)									110

Note: Boom angles are in degrees.

A6-829-008824A

*60 ft. boom length is with inner-mid extended and outer-mid & fly retracted.

#LMI operating code. Refer to LMI manual for instructions.

ON RUBBER CAPACITIES WITH 23.5 x 25 TIRES (cont'd.)

PICK & CARRY CAPACITIES - UP TO 2.5 MPH BOOM CENTERED OVER FRONT (SEE NOTE 7)

Radius in Feet	#06						
	Main Boom Length in Feet						
	35	40	50	*60	70	80	90
10	38,000 (66)	31,450 (69.5)	30,000 (74)				
12	33,150 (62)	29,000 (66)	27,750 (71.5)	26,750 (75)			
15	27,300 (56)	27,300 (61)	25,000 (67.5)	22,750 (71.5)	17,300 (74.5)	14,500 (77)	
20	20,750 (44.5)	20,750 (52)	20,450 (61)	17,300 (66.5)	13,750 (70.5)	12,500 (73.5)	11,500 (75.5)
25	15,950 (28.5)	15,850 (41.5)	15,850 (54)	13,400 (61)	11,000 (66)	11,000 (69.5)	10,150 (72)
30		11,850 (27)	11,500 (46)	10,600 (55)	9,300 (61)	9,300 (65.5)	9,300 (68.5)
35			8,220 (36.5)	7,910 (49)	8,200 (56)	8,200 (61.5)	8,200 (65)
40			5,910 (24)	5,680 (41.5)	5,980 (50.5)	5,980 (57)	5,980 (61.5)
45				4,030 (33)	4,170 (45)	4,170 (52.5)	4,170 (57.5)
50				2,760 (21.5)	2,770 (38.5)	2,770 (47.5)	2,770 (53.5)
55					1,840 (31)	1,840 (42)	1,840 (49.5)
60					1,290 (20)	1,290 (36)	1,290 (45)

Note: () Boom angles are in degrees.

#LMI operating code. Refer to LMI manual for instructions.

*60 ft. boom length is with inner-mid extended and outer-mid & fly retracted.

A6-828-009207

NOTES TO ALL RUBBER CAPACITY CHARTS:

1. Capacities are in pounds and do not exceed 75% of tipping loads as determined by test in accordance with SAE J765 OCT80.
2. Capacities are applicable to machines equipped with 23.5 x 25 XRA Michelin, at 70 psi cold inflation pressure.
3. Defined Arc - Over front includes 6' on either side of longitudinal centerline of machine (ref. working area diagram).
4. Capacities appearing above the bold line are based on structural strength and tipping should not be relied upon as a capacity limitation.
5. Capacities are applicable only with machine on firm level surface.
6. On rubber lifting with boom extensions not permitted.
7. For pick and carry operation, boom must be centered over front of machine, mechanical swing lock engaged and load restrained from swinging. When handling loads in the structural range with capacities close to maximum ratings, travel should be reduced to creep speeds.
8. Axle lockouts must be functioning before lifting on rubber. (Check automatic lockout system for proper functioning; refer to "Operation and Maintenance Manual" for description of a proper functioning axle lockout system).
9. All lifting depends on proper tire inflation, capacity and condition. Capacities must be reduced for lower tire inflation pressures. See lifting capacity chart for tire used. Damaged tires are hazardous to safe operation of crane.
10. Creep - not over 200 ft. of movement in any 30 minute period and not exceeding 1 mph.

	No Load Stability Data	Main Boom 110 ft.
Front (No load)	Min. boom angle (deg.) for indicated length	40
	Max. boom length (ft.) at 0 deg. boom angle	70
360 Deg. (No load)	Min. boom angle (deg.) for indicated length	55
	Max. boom length (ft.) at 0 deg. boom angle	50

32 FT. FIXED LENGTH EXTENSION

BOOM EXTENSION CAPACITY NOTES:

1. All capacities above the bold line are based on structural strength of boom extension.
2. 32 ft. boom extension lengths may be used for double or single line lifting service.
3. Radii listed are for a fully extended boom with the boom extension erected. For main boom lengths less than fully extended, the rated loads are determined by boom angle. Use only the column which corresponds to the boom extension length and offset for which the machine is configured. For boom angles not shown, use the rating of the next lower boom angle.

WARNING: Operation of this machine with heavier loads than the capacities listed is strictly prohibited. Machine tipping with boom extension occurs rapidly and without advance warning.

4. Boom angle is the angle above or below horizontal of the longitudinal axis of the boom base section after lifting rated load.
5. Capacities listed are with outriggers fully extended and vertical jacks set only.
6. ***32 FT. FIXED OFFSETTABLE BOOM EXTENSION WARNING:**
For main boom length greater than 80 ft. with 32 ft. fixed boom extension in working position, the boom angle must not be less than 40° since loss of stability will occur causing a tipping condition. The boom angle is not restricted for main boom length equal to or less than 80 ft.

* This warning also applies for boom extension erection purposes.

ON OUTRIGGERS - 360°

Radius in Feet	#51 0° OFFSET		#52 15° OFFSET		#53 30° OFFSET	
	Boom Ang. (Deg.)	Cap. lbs.	Boom Ang. (Deg.)	Cap. lbs.	Boom Ang. (Deg.)	Cap. lbs.
30	78.0	8,880				
35	75.5	8,480	78.0	*7,380		
40	73.5	7,980	75.5	6,980	78.0	*6,180
45	71.5	7,480	73.5	6,580	76.0	5,850
50	69.0	6,980	71.5	6,180	73.5	5,340
55	67.0	6,430	69.0	5,800	71.5	4,980
60	64.5	5,880	67.0	5,450	69.0	4,780
65	62.0	5,240	64.5	5,110	67.0	4,620
70	59.5	4,650	62.0	4,650	64.5	4,470
75	57.0	4,120	59.5	4,120	62.0	4,120
80	54.5	3,640	57.0	3,640	59.5	3,640
85	52.0	2,960	54.5	2,960	57.0	2,960
90	49.0	2,370	52.0	2,370	54.0	2,370
95	46.5	1,850	49.0	1,850	51.0	1,850
100	43.5	1,380	46.0	1,380	48.0	1,380

A6-829-008842A

*This capacity is based upon the maximum boom angle.
#LMI operating code. Refer to LMI manual for instructions.

32 FT. - 56 FT. TELE OFFSETTABLE BOOM EXTENSION

ON OUTRIGGERS - 360°

Radius In Feet	32 ft. LENGTH			44 ft. LENGTH			56 ft. LENGTH		
	#21	#22	#23	#31	#32	#33	#41	#42	#43
	0° OFFSET Boom Angle Ref. (Deg.) Cap. lbs.	15° OFFSET Boom Angle Ref. (Deg.) Cap. lbs.	30° OFFSET Boom Angle Ref. (Deg.) Cap. lbs.	0° OFFSET Boom Angle Ref. (Deg.) Cap. lbs.	15° OFFSET Boom Angle Ref. (Deg.) Cap. lbs.	30° OFFSET Boom Angle Ref. (Deg.) Cap. lbs.	0° OFFSET Boom Angle Ref. (Deg.) Cap. lbs.	15° OFFSET Boom Angle Ref. (Deg.) Cap. lbs.	30° OFFSET Boom Angle Ref. (Deg.) Cap. lbs.
30	78.0	8,500		78.0	*5,100				
35	75.5	8,100	78.0	76.5	5,060				
40	73.5	7,600	6,600	74.5	5,000				
45	71.5	7,100	6,200	73.0	4,900	4,300			
50	69.0	6,600	5,800	71.0	4,750	4,110			
55	67.0	6,050	5,420	68.5	4,550	3,920			
60	64.5	5,500	5,070	66.5	4,300	3,750			
65	62.0	4,860	4,730	64.5	4,010	3,570			
70	59.5	4,270	4,270	62.5	3,710	3,400			
75	57.0	3,740	3,740	60.5	3,400	3,280			
80	54.5	3,260	3,260	58.0	3,090	3,000			
85	52.0	2,580	2,580	56.0	2,790	2,790			
90	49.0	1,990	1,990	53.5	2,500	2,500			
95	46.5	1,470	1,470	51.0	1,990	1,990			
100	43.5	1,000	1,000	48.0	1,520	1,520			
105				46.0	1,100	1,100			

*This capacity is based upon maximum boom angle.

#LMI operating code. Refer to LMI manual for instructions.

A6-829-008841

- All capacities above the bold line are based on structural strength of boom extension.
- 32 ft., 44 ft. and 56 ft. boom extension lengths may be used for double or single line lifting service.
- Radii listed are for a fully extended boom with the boom extension erected. For main boom lengths less than fully extended, the rated loads are determined by boom angle. Use only the column which corresponds to the boom extension length and offset for which the machine is configured. For boom angles not shown, use the rating of the next lower boom angle.
WARNING: Operation of this machine with heavier loads than the capacities listed is strictly prohibited. Machine tipping with boom extension occurs rapidly and without advance warning.
- Boom angle is the angle above or below horizontal of the longitudinal axis of the boom base section after lifting rated load.
- Capacities listed are with outriggers fully extended and vertical jacks set only.
- 32 ft. - 56 ft. TELE OFFSETTABLE BOOM EXTENSION **WARNING:** For main boom length greater than 80 ft. with 32 ft. - 56 ft. tele boom extension in working position, the boom angle must not be less than 40° since loss of stability will occur causing a tipping condition. The boom angle is not restricted for main boom length equal to or less than 80 ft. This warning also applies for boom extension erection purposes.

LINE PULLS & REEVING INFORMATION

HOISTS	CABLE SPECS.	PERMISSIBLE LINE PULLS
MAIN & AUX. Model 30	3/4 in. (19 mm) 18x19 Class or 35x7 Rotation Resistant Min. Breaking Str. 64,600 lbs.	12,920 lbs.

WEIGHT REDUCTIONS FOR LOAD HANDLING DEVICES

32 ft. Extension with 35 ft.- 110 ft. Boom	
*Stowed -	671 lbs.
*Erected -	4,149 lbs.

32 ft. - 56 ft. Tele. Ext. with 35 ft.- 110 ft. Boom	
*Stowed -	846 lbs.
*Erected (ret.) -	6,368 lbs.
*Erected (ext.) -	8,287 lbs.

*Reduction of main boom capacities

HOOKBLOCKS:	
15 Ton, 1 Sheave	380 lbs.
30 Ton, 2 Sheave	843 lbs.
40 Ton, 4 Sheave	910 lbs.
40 Ton, 4 Sheave(w/cheek plates)	1100 lbs.
45 Ton, 3 Sheave	895 lbs.
45 Ton, 3 Sheave(w/cheek plates)	1095 lbs.
Auxiliary Boom Nose	143 lbs.
10 Ton Headache Ball	560 lbs.
7 1/2 Ton Headache Ball	338 lbs.

When lifting over swingaway and/or jib combinations, deduct total weight of all load handling devices reeved over main boom nose directly from swingaway or jib capacity.

NOTE: All load handling devices and boom attachments are considered part of the load and suitable allowances **MUST BE MADE** for their combined weights. Weights are for Grove furnished equipment.

WORKING RANGE DIAGRAM
 (BOOM DEFLECTION NOT SHOWN) D6-829-008542

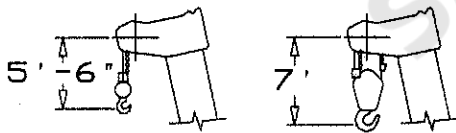
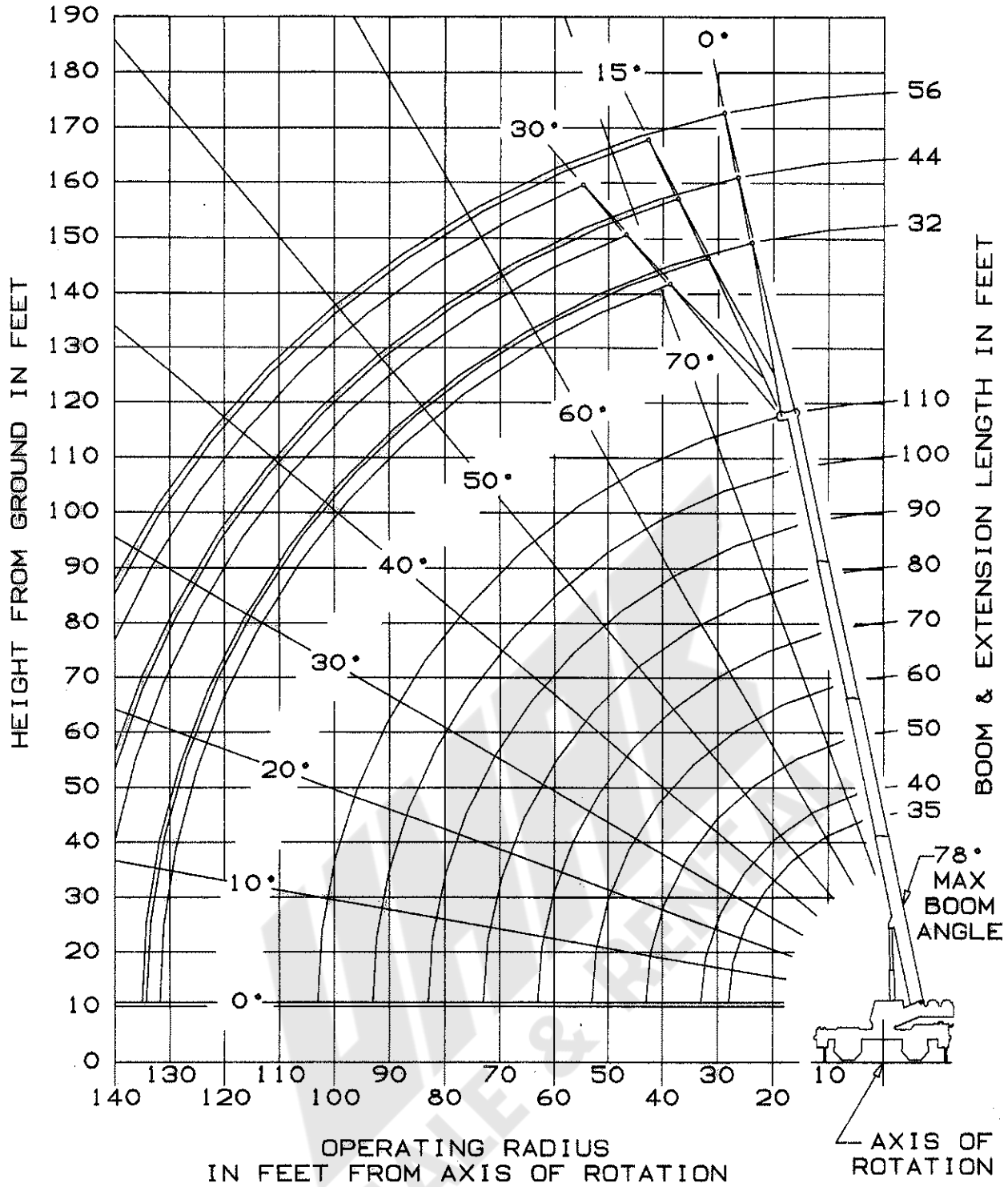

DIMENSIONS ARE FOR LARGEST GROVE FURNISHED HOOK BLOCK AND HEADACHE BALL, WITH ANTI-TWO BLOCK ACTIVATED.

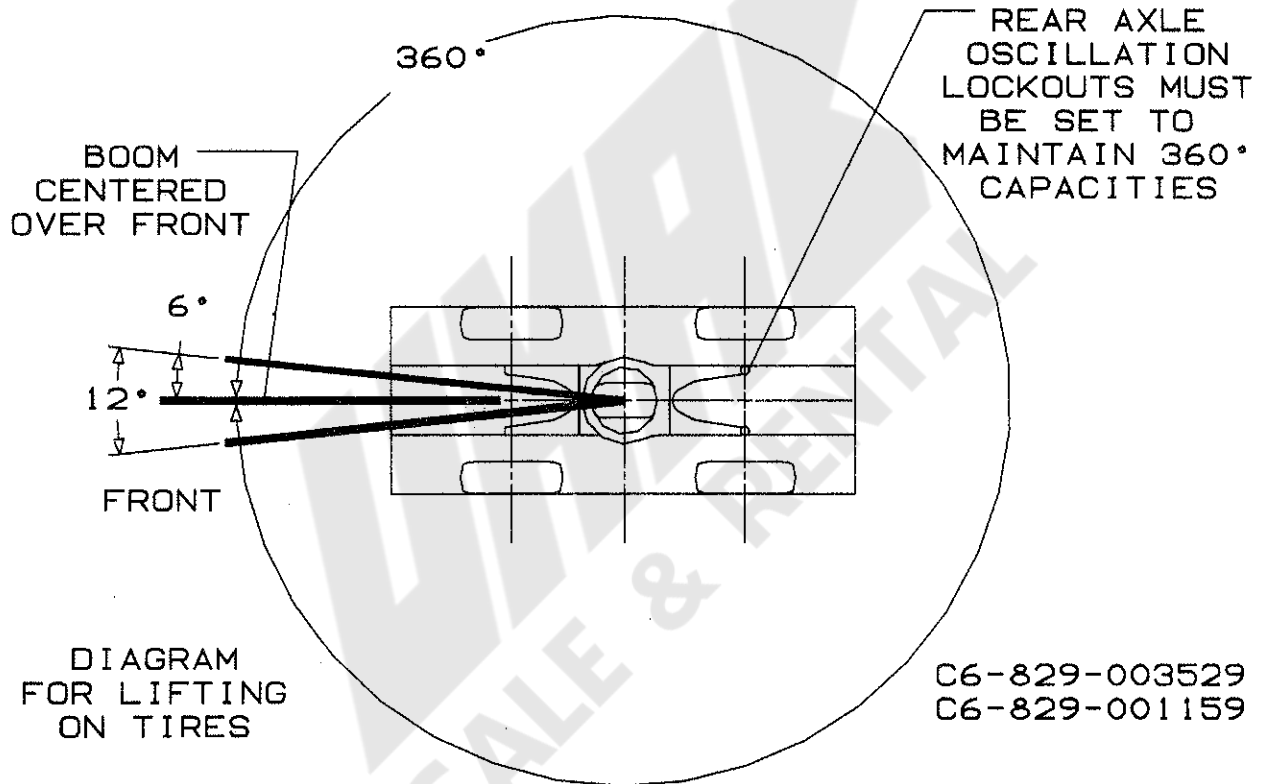
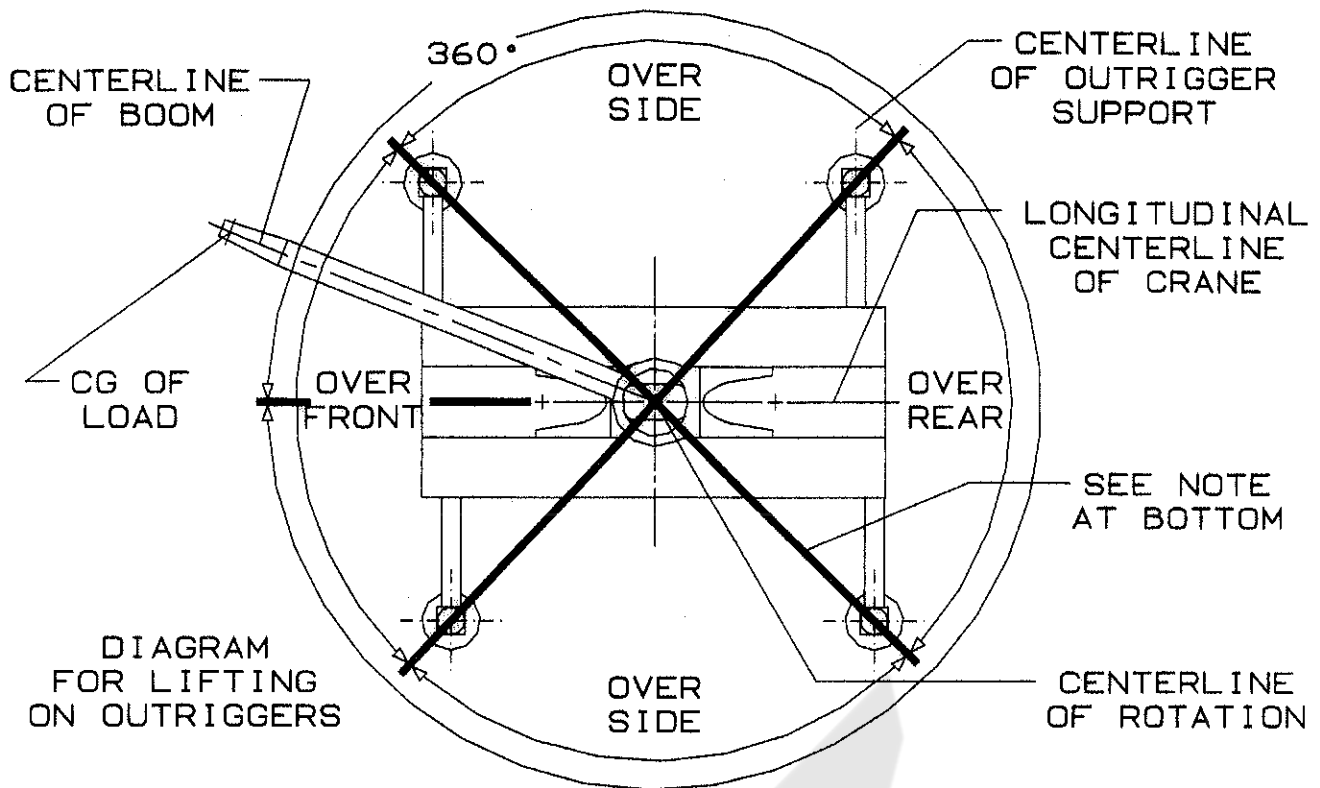

C6-829-003529
C6-829-001159

BOLD LINES DETERMINE THE LIMITING POSITION OF ANY LOAD FOR OPERATION WITHIN WORKING AREAS INDICATED

WORKING AREA DIAGRAM

ZERO DEGREE BOOM ANGLE CHARTS

ON OUTRIGGERS - 360 DEGREES

Boom Angle	Main Boom Length in Feet								
	35	40	50	*60	70	80	90	100	110
0°	15,490 (27.8)	12,240 (33)	7,860 (43)	4,970 (52.8)	3,670 (63)	2,710 (73)	1,960 (83)	1,360 (93)	880 (102.8)

ON RUBBER

Stationary Capacity Defined Arc (3) Over Front

Boom Angle	Main Boom Length in Feet				
	35	40	50	*60	70
0°	13,900 (27.8)	9,660 (33)	4,830 (43)	2,160 (52.8)	1,010 (63)

Stationary Capacity 360° Arc

Boom Angle	Main Boom Length in Feet		
	35	40	50
0°	6,910 (27.8)	4,190 (33)	970 (43)

Pick & Carry Capacities Up to 2.5 MPH Boom Centered (7) Over Front

Boom Angle	Main Boom Length in Feet				
	35	40	50	*60	70
0°	13,900 (27.8)	9,660 (33)	4,830 (43)	2,160 (52.8)	1,010 (63)

A6-829-009334

Note: () Reference radii in feet

*60 ft. boom length is with inner-mid extended and outer-mid & fly ret.

Refer to in-cab load chart for notes.

TRANSPORTATION AND LIFTING DATA RT700B

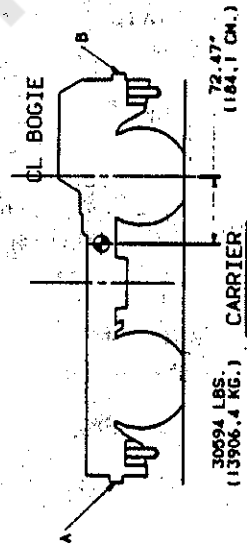
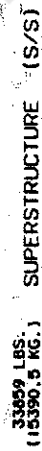
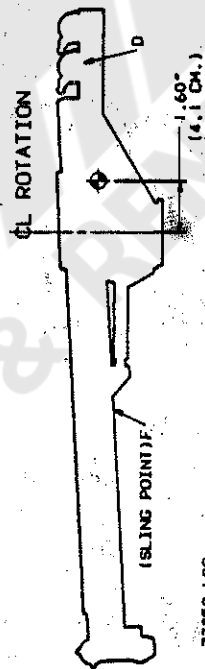
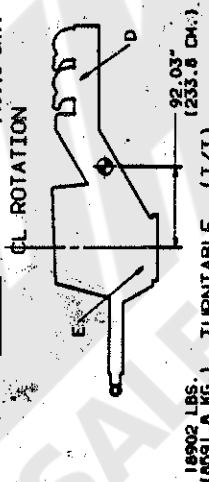
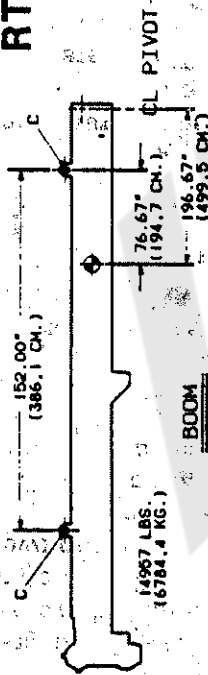

FITTINGS	TOTAL UNIT		CAR-RIER	S/S	T/T	BOOM		FITTING CAPACITY (TONS)			
	LIFT	TIE DOWN				LIFT	LIFT	TIE DOWN	FORE & AFT	SIDE DOWN	
A 2	X	X	X	X				100	129	33	65
B 2	X	X	X	X				100	129	33	65
C 4					X						
D 2					X						
E 2				X							
F 1											
G 4	X										

- LIFTING OF ENTIRE CRANE OR MAJOR CRANE ASSEMBLIES MUST BE ACCOMPLISHED BY UTILIZING SPECIFIC FITTINGS INDICATED ON ABOVE CHART. USE OF FITTINGS FOR PURPOSES OTHER THAN THOSE DESIGNATED ON CHART IS PROHIBITED. FITTING CAPACITIES ARE MAXIMUM ALLOWABLE LOADS PER INDIVIDUAL FITTING. RIGGING PERSONNEL SHALL BE RESPONSIBLE FOR PROPER SELECTION AND PLACEMENT OF ALL SLINGS AND LOAD HANDLING DEVICES.
- RIGGING PERSONNEL SHALL BE RESPONSIBLE FOR PROPER DIMENSIONS AND WEIGHTS SHOWN ARE FOR LARGEST CONFIGURATION AVAILABLE. WEIGHTS DO NOT INCLUDE BOOM EXTENSION AND/OR JIB.
- RIGGING PERSONNEL SHALL VERIFY DIMENSIONS AS REQUIRED FOR CLEARANCE.
- EXTEND OUTRIGGER BEAMS 18" (45.5 CM.) AND SLING AROUND BEAMS.

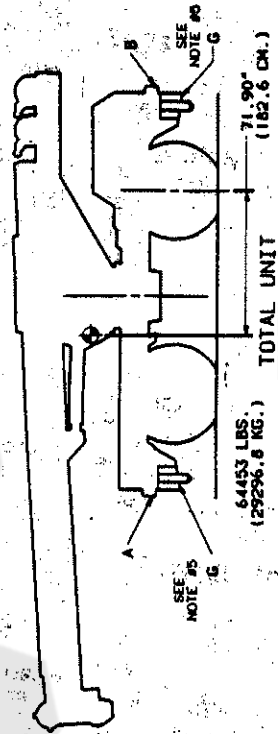

Transportation and Lifting Data Decal



GROVE[®]
worldwide

RT740B

Rough terrain hydraulic crane
35 ft. - 110 ft. full power boom

WORKING RANGE DIAGRAM (BOOM DEFLECTION NOT SHOWN)

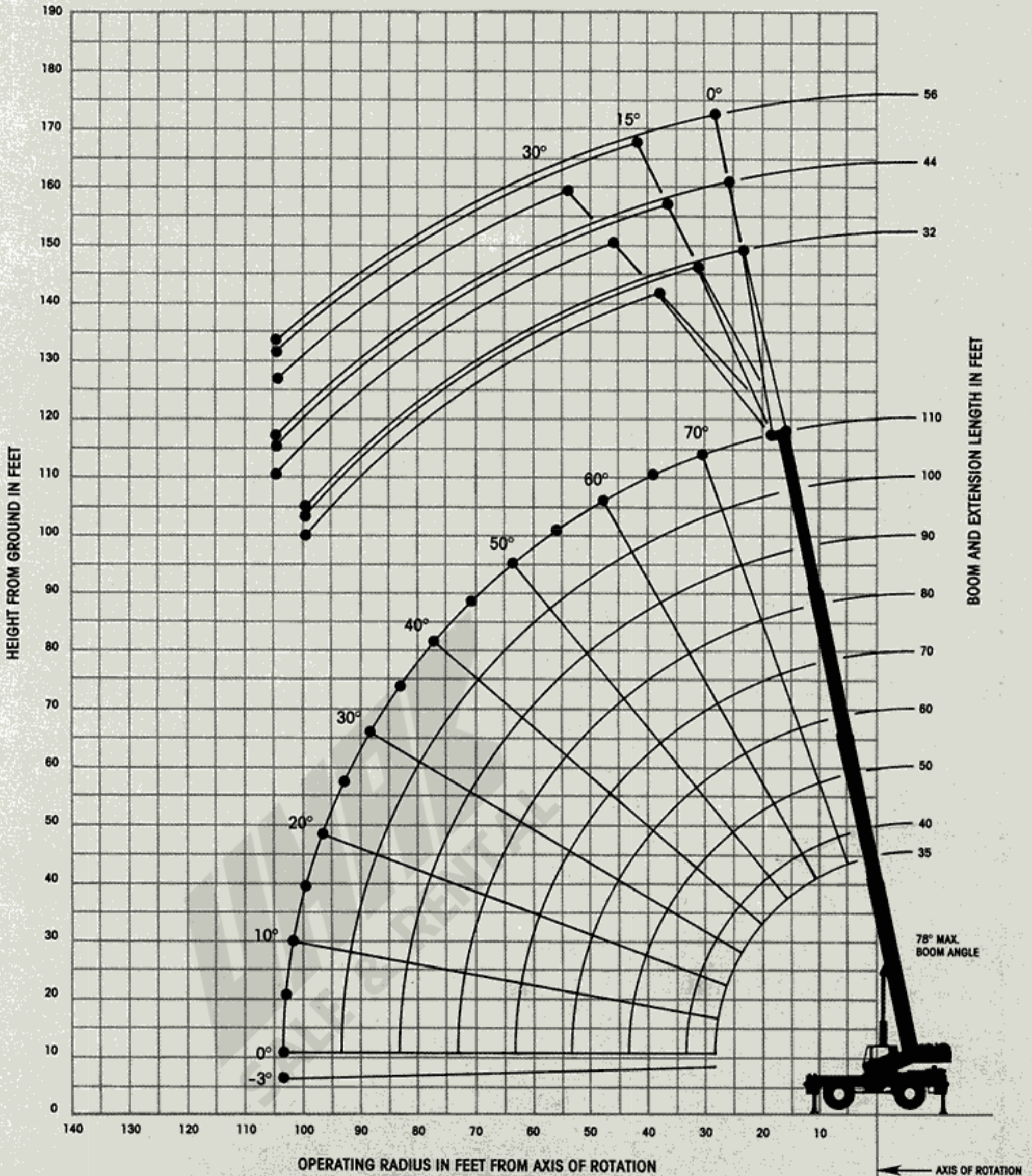

NOTES FOR LIFTING CAPACITIES

WARNING: THIS CHART IS ONLY A GUIDE. The Notes below are for illustration only and should not be relied upon to operate the crane. The individual crane's load chart, operating instructions and other instruction plates must be read and understood prior to operating the crane.

- All rated loads have been tested to and meet minimum requirements of SAE J1063 OCT80 - Cantilevered Boom Crane Structures - Method of Test, and do not exceed 85% of the tipping load on outriggers (75% of the tipping load on rubber) as determined by SAE J765 OCT 80 Crane Stability Test Code.
- Capacities given do not include the weight of hookblocks, slings, auxiliary lifting equipment and load handling devices. Their weights **MUST** be added to the load to be lifted. When more than minimum required reeving is used, the additional rope weight shall be considered part of the load.
- Defined Arc $\pm 6^\circ$ on either side of longitudinal centerline of machine.
- All capacities are for crane on firm, level surface. It may be necessary to have structural supports under the outrigger floats or tires to spread the load to a larger bearing surface.
- When either boom length or radius or both are between values listed, the smallest load shown at either the next larger radius or boom length shall be used.
- For outrigger operation, ALL outriggers shall be fully extended with tires raised free of ground before raising the boom or lifting loads.
- Tires shall be inflated to the recommended pressure before lifting on rubber.
- Unless otherwise stated, capacities are with powered boom sections equally extended.
- Capacities appearing above the bold line are based on structural strength and tipping should not be relied upon as a capacity limitation.
- With boom extension in working position and main boom length greater than 80 ft., boom angle must not be less than 40° since loss of stability will occur causing a tipping condition.

Constant improvement and engineering progress make it necessary that we reserve the right to make specification, equipment, and price changes without notice. Illustrations shown may include optional equipment and accessories and may not include all standard equipment.



Grove Worldwide - World Headquarters
1565 Buchanan Trail East
Shady Grove, Pennsylvania 17256
Phone: (717) 597-8121 Telex: 1842308 Fax: (717) 597-4062

Grove North America
P.O. Box 21, Shady Grove, Pennsylvania 17256
Western Hemisphere, Asia/Pacific
Phone: (717) 597-8121 Telex: 1842308 Fax: (717) 597-4062

Grove Europe*
Sunderland, England SR4 6TT
Europe, Africa, Middle East, Near East
Phone: (091) 565-6281 Telex: 53484 CRANESG FAX: (091) 564-0442
*Grove Europe Limited, Registered in England, Number 1845128, Registered office, Crown Works, Pallion, Sunderland, Tyne & Wear, England SR4 6TT.

FORM NO.: LC-RT740B P/N: 3-517 892-5M PRINTED IN U.S.A.

23.5xR25 MICHELIN TIRES ON RUBBER (STATIONARY DEFINED ARC OVER FRONT)

Radius in Feet	Main Boom Length in Feet							
	35	40	50	60	70	80	90	100
10	37,300 (66)	31,100 (69.5)	22,150 (74)					
12	32,700 (62)	26,250 (66)	20,000 (71.5)	18,300 (75)				
15	27,500 (56)	23,000 (61)	18,300 (67.5)	16,950 (71.5)				
20	21,550 (44.5)	20,750 (52)	16,950 (61)	13,500 (66.5)	11,400 (70.5)	10,300 (73.5)		
25	16,950 (28.5)	16,950 (41.5)	13,600 (54)	11,300 (61)	10,250 (66)	9,250 (69.5)	8,050 (72)	6,500 (74.5)
30		11,850 (27)	11,400 (46)	10,000 (55)	9,300 (61)	8,500 (65.5)	7,350 (68.5)	5,900 (71.5)
35			8,220 (36.5)	7,910 (49)	8,430 (56)	7,800 (61.5)	6,850 (65)	5,600 (68)
40			5,910 (24)	5,680 (41.5)	5,980 (50.5)	5,980 (57)	5,980 (61.5)	5,300 (65)
45				4,030 (33)	4,170 (45)	4,170 (52.5)	4,170 (57.5)	4,170 (61.5)
50				2,760 (21.5)	2,770 (38.5)	2,770 (47.5)	2,770 (53.5)	2,770 (58.5)
55					1,840 (31)	1,840 (42)	1,840 (49.5)	1,840 (54.5)
60					1,290 (20)	1,290 (36)	1,290 (45)	1,290 (51)

A6-829-0011010

ON RUBBER (STATIONARY - 360°)

Radius in Feet	Main Boom Length in Feet							
	35	40	50	60	70	80	90	100
10	33,000 (66)	31,100 (69.5)	22,150 (74)					
12	27,350 (62)	26,250 (66)	19,000 (71.5)	18,300 (75)				
15	21,300 (56)	21,300 (61)	16,000 (67.5)	15,500 (71.5)				
20	13,150 (44.5)	12,750 (52)	12,400 (61)	12,400 (66.5)	10,300 (70.5)	6,170 (73.5)		
25	8,630 (28.5)	8,230 (41.5)	7,840 (54)	7,790 (61)	7,850 (66)	6,170 (69.5)	4,500 (72)	2,050 (74.5)
30		5,410 (27)	5,000 (46)	4,870 (56)	5,410 (61)	5,200 (65.5)	4,500 (68.5)	2,050 (71.5)
35			3,100 (36.5)	2,870 (49)	3,380 (56)	3,380 (61.5)	3,120 (65)	2,050 (68)
40			1,650 (24)	1,430 (41.5)	1,750 (50.5)	1,750 (57)	1,710 (61.5)	1,710 (65)

A6-829-0011010

ON RUBBER (PICK & CARRY CAPACITIES UP TO 2.5 MPH)

Radius in Feet	Main Boom Length in Feet							
	35	40	50	60	70	80	90	
10	38,000 (66)	31,450 (69.5)						
12	33,150 (62)	29,000 (66)	27,750 (71.5)					
15	27,300 (56)	27,300 (61)	25,000 (67.5)	22,750 (71.5)				
20	20,750 (44.5)	20,750 (52)	20,450 (61)	17,300 (66.5)	13,750 (70.5)			
25	15,950 (28.5)	15,850 (41.5)	15,850 (54)	13,400 (61)	11,000 (66)	11,000 (69.5)	10,150 (72)	
30		11,850 (27)	11,500 (46)	10,600 (55)	9,300 (61)	9,300 (65.5)	9,300 (68.5)	
35			8,220 (36.5)	7,910 (49)	8,200 (56)	8,200 (61.5)	8,200 (65)	
40			5,910 (24)	5,680 (41.5)	5,980 (50.5)	5,980 (57)	5,980 (61.5)	
45				4,030 (33)	4,170 (45)	4,170 (52.5)	4,170 (57.5)	
50				2,760 (21.5)	2,770 (38.5)	2,770 (47.5)	2,770 (53.5)	
55					1,840 (31)	1,840 (42)	1,840 (49.5)	
60					1,290 (20)	1,290 (36)	1,290 (45)	

NOTE: () Boom angles are in degrees.

A6-829-0011010

NOTES FOR RUBBER CAPACITIES

	No Load Stability Data	Main Boom 110 ft.
Front (No load)	Min. boom angle (deg.) for indicated length	40
	Max. boom length (ft.) at 0 deg. boom angle	70
360 Deg. (No load)	Min. boom angle (deg.) for indicated length	55
	Max. boom length (ft.) at 0 deg. boom angle	50

32 FT. OFFSETTABLE EXTENSION ON OUTRIGGERS - 360°

Radius in Feet	0° OFFSET		15° OFFSET		30° OFFSET	
	Boom Ang. (Deg.)	Cap. lbs.	Boom Ang. (Deg.)	Cap. lbs.	Boom Ang. (Deg.)	Cap. lbs.
30	78.0	8,880				
35	75.5	8,480	78.0	7,380		
40	73.5	7,980	75.5	6,980	78.0	6,180
45	71.5	7,480	73.5	6,580	76.0	5,850
50	69.0	6,980	71.5	6,180	73.5	5,340
55	67.0	6,430	69.0	5,800	71.5	4,980
60	64.5	5,880	67.0	5,450	69.0	4,780
65	62.0	5,240	64.5	5,110	67.0	4,620
70	59.5	4,650	62.0	4,650	64.5	4,470
75	57.0	4,120	59.5	4,120	62.0	4,120
80	54.5	3,640	57.0	3,640	59.5	3,640
85	52.0	2,960	54.5	2,960	57.0	2,960
90	49.0	2,370	52.0	2,370	54.0	2,370
95	46.5	1,850	49.0	1,850	51.0	1,850
100	43.5	1,380	46.0	1,380	48.0	1,380

A6-829-008842A

WEIGHT REDUCTIONS FOR LOAD HANDLING DEVICES

32 ft. Extension with 35 ft.- 110 ft. Boom	
*Stowed -	671 lbs.
*Erected -	4,149 lbs.

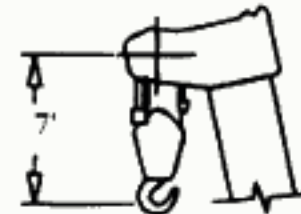
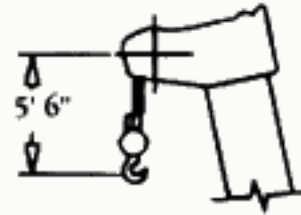

DIMENSIONS ARE FOR LARGEST GROVE FURNISHED HOOK BLOCK AND HEADACHE BALL, WITH ANTI-TWO BLOCK ACTIVATED.

32 ft. - 56 ft. Tele. Ext. with 35 ft.- 110 ft. Boom	
*Stowed -	846 lbs.
*Erected (ref.) -	6,368 lbs.
*Erected (ext.) -	8,287 lbs.

*Reduction of main boom capacities

HOOKBLOCKS:	
15 Ton, 1 Sheave	380 lbs.
30 Ton, 2 Sheave	843 lbs.
40 Ton, 4 Sheave	910 lbs.
40 Ton, 4 Sheave(w/cheek plates)	1100 lbs.
45 Ton, 3 Sheave	895 lbs.
45 Ton, 3 Sheave(w/cheek plates)	1095 lbs.
Auxiliary Boom Nose	143 lbs.
10 Ton Headache Ball	560 lbs.
7 1/2 Ton Headache Ball	338 lbs.

35 FT. - 110 FT. POWER BOOM ON OUTRIGGERS FULLY EXTENDED - 360°

Radius in Feet	Main Boom Length in Feet									
	35	40	50	60	70	80	90	100	110	
10	80,000 (66)	68,000 (69.5)	58,100 (74)							
12	67,400 (62)	62,700 (66)	53,700 (71.5)	44,600 (75)						
15	56,500 (56)	54,500 (61)	48,050 (67.5)	41,550 (71.5)	35,600 (74.5)	33,000 (77)				
20	44,000 (44.5)	43,000 (52)	39,400 (61)	33,550 (66.5)	30,500 (70.5)	28,000 (73.5)	25,500 (75.5)	22,150 (77.5)		
25	33,500 (28.5)	33,000 (41.5)	32,400 (54)	27,750 (61)	25,200 (66)	23,800 (69.5)	21,950 (72)	20,400 (74.5)	18,500 (76)	
30		26,500 (27)	25,500 (46)	23,300 (55)	21,050 (61)	20,400 (65.5)	19,300 (68.5)	17,550 (71.5)	15,750 (73.5)	
35			20,300 (36.5)	20,000 (49)	17,950 (56)	17,400 (61.5)	16,400 (65)	15,050 (68)	13,650 (70.5)	
40			16,000 (24)	15,850 (41.5)	15,500 (50.5)	15,050 (57)	14,100 (61.5)	13,100 (65)	12,000 (68)	
45				12,250 (33)	13,000 (45)	13,000 (52.5)	12,300 (57.5)	11,450 (61.5)	10,600 (65)	
50					9,720 (21.5)	10,350 (38.5)	10,750 (47.5)	10,800 (53.5)	10,000 (58.5)	
55						8,300 (31)	8,770 (42)	9,170 (49.5)	8,830 (54.5)	
60						6,650 (20)	7,150 (36)	7,850 (45)	7,840 (51)	
65							5,830 (29)	6,340 (40)	6,820 (47)	
70							4,740 (19)	5,100 (34)	5,590 (42.5)	
75								4,050 (27.5)	4,540 (38)	
80								3,160 (18)	3,650 (32.5)	
85									2,870 (26)	
90									2,190 (17)	
95									2,170 (25)	
100									1,790 (16)	
Minimum boom angle (deg.) for indicated length (no load)										0
Maximum boom length (ft.) at 0 deg. boom angle (no load)										110

Note: () Boom angles are in degrees.

*60 ft. boom length is with inner-mid extended and outer-mid & fly retracted.

A6-829-008842A

32 FT. - 56 FT. TELE OFFSETTABLE EXTENSION (ON OUTRIGGERS - 360°)

Radius in Feet	32 ft. LENGTH						44 ft. LENGTH						56 ft. LENGTH					
	0° OFFSET		15° OFFSET		30° OFFSET		0° OFFSET		15° OFFSET		30° OFFSET		0° OFFSET		15° OFFSET		30° OFFSET	
	Boom Angle Ref. (Deg.)	Cap. lbs.	Boom Angle Ref. (Deg.)	Cap. lbs.	Boom Angle Ref. (Deg.)	Cap. lbs.	Boom Angle Ref. (Deg.)	Cap. lbs.	Boom Angle Ref. (Deg.)	Cap. lbs.	Boom Angle Ref. (Deg.)	Cap. lbs.	Boom Angle Ref. (Deg.)	Cap. lbs.	Boom Angle Ref. (Deg.)	Cap. lbs.	Boom Angle Ref. (Deg.)	Cap. lbs.
30	78.0	8,500					78.0	5,100										
35	75.5	8,100	78.0	7,000			76.5	5,060										
40	73.5	7,600	75.5	6,600	78.0	5,800	74.5	5,000					76.5	4,000				
45	71.5	7,100	73.5	6,200	76.0	5,470	73.0	4,900	76.5	4,300			74.5	3,920				
50	69.0	6,600	71.5	5,800	73.5	4,960	71.0	4,750	74.5	4,110	77.5	3,300	73.0	3,840	77.0	3,300		
55	67.0	6,050	69.0	5,420	71.5	4,600	68.5	4,550	72.5	3,920	75.0	3,200	71.0	3,770	75.0	3,100		
60	64.5	5,500	67.0	5,070	69.0	4,400	66.5	4,300	70.5	3,750	73.0	3,100	69.5	3,700	73.5	2,920	77.5	2,300
65	62.0	4,860	64.5	4,730	67.0	4,240	64.5	4,010	68.5	3,570	71.0	3,000	67.5	3,610	71.5	2,760	75.5	2,200
70	59.5	4,270	62.0	4,270	64.5	4,090	62.5	3,710	66.5	3,400	69.0	2,900	65.5	3,500	69.5	2,620	73.5	2,100
75	57.0	3,740	59.5	3,740	62.0	3,740	60.5	3,400	64.0	3,200	66.5	2,800	64.0	3,310	68.0	2,500	71.5	2,020
80	54.5	3,260	57.0	3,260	59.5	3,260	58.0	3,090	62.0	3,000	64.5	2,700	62.0	3,000	66.0	2,400	69.5	1,950
85	52.0	2,580	54.5	2,580	57.0	2,580	56.0	2,790	60.0	2,790	62.0	2,600	60.0	2,510	64.0	2,300	67.5	1,880
90	49.0	1,990	52.0	1,990	54.0	1,990	53.5	2,500	57.5	2,500	59.5	2,500	58.0	2,020	61.5	2,020	65.5	1,810
95	46.5	1,470	49.0	1,470	51.0	1,470	51.0	1,990	55.0	1,990	57.0	1,990	56.0	1,660	59.5	1,660	63.0	1,660
100	43.5	1,000	46.0	1,000	48.0	1,000	48.5	1,520	52.5	1,520	54.5	1,520	53.5	1,230	57.5	1,230	61.0	1,230
105							46.0	1,100	50.0	1,100	51.5	1,100	51.5	850	55.0	850	58.5	850

*This capacity is based upon maximum boom angle.

A6-829-008841

WORKING AREA DIAGRAM

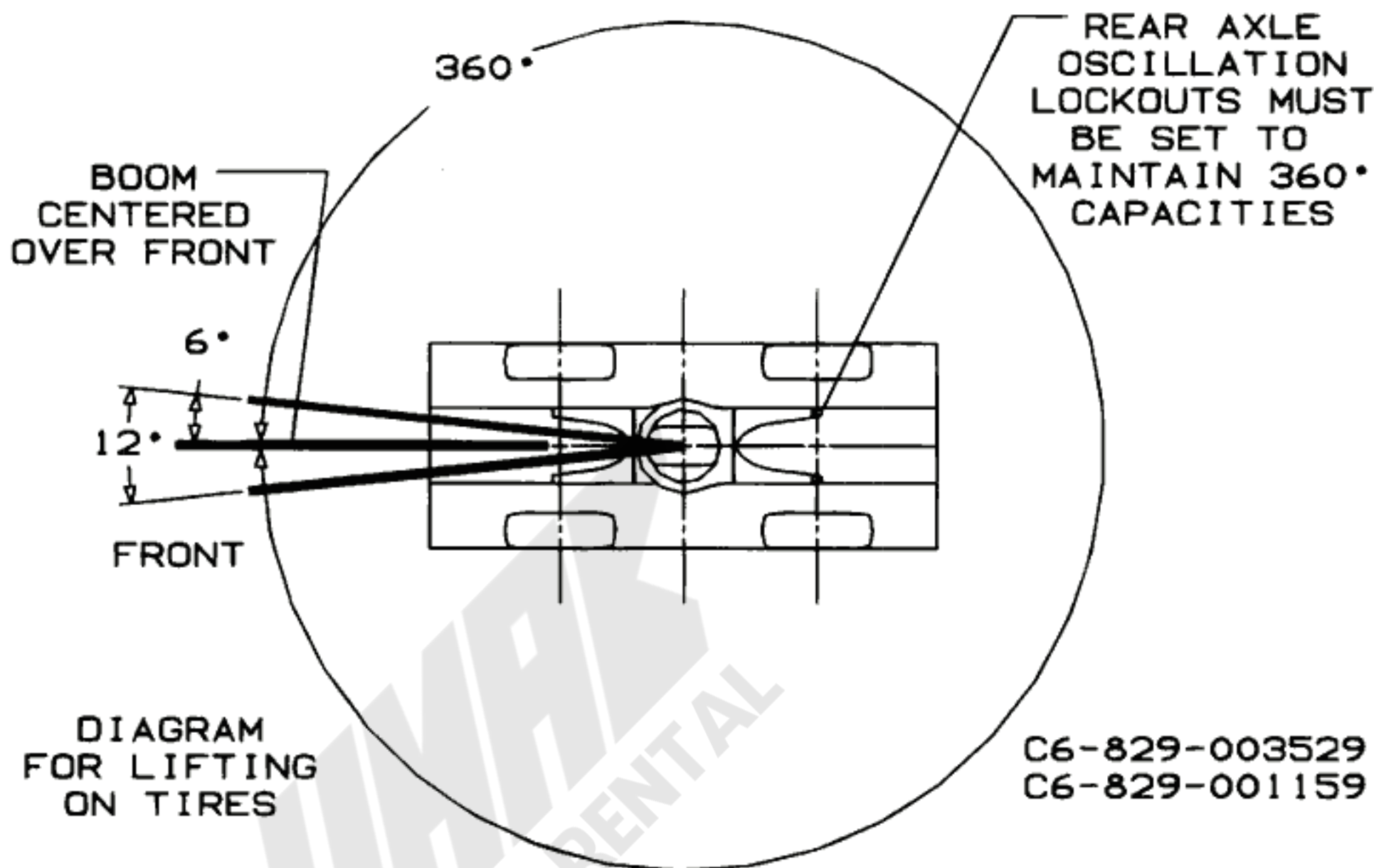
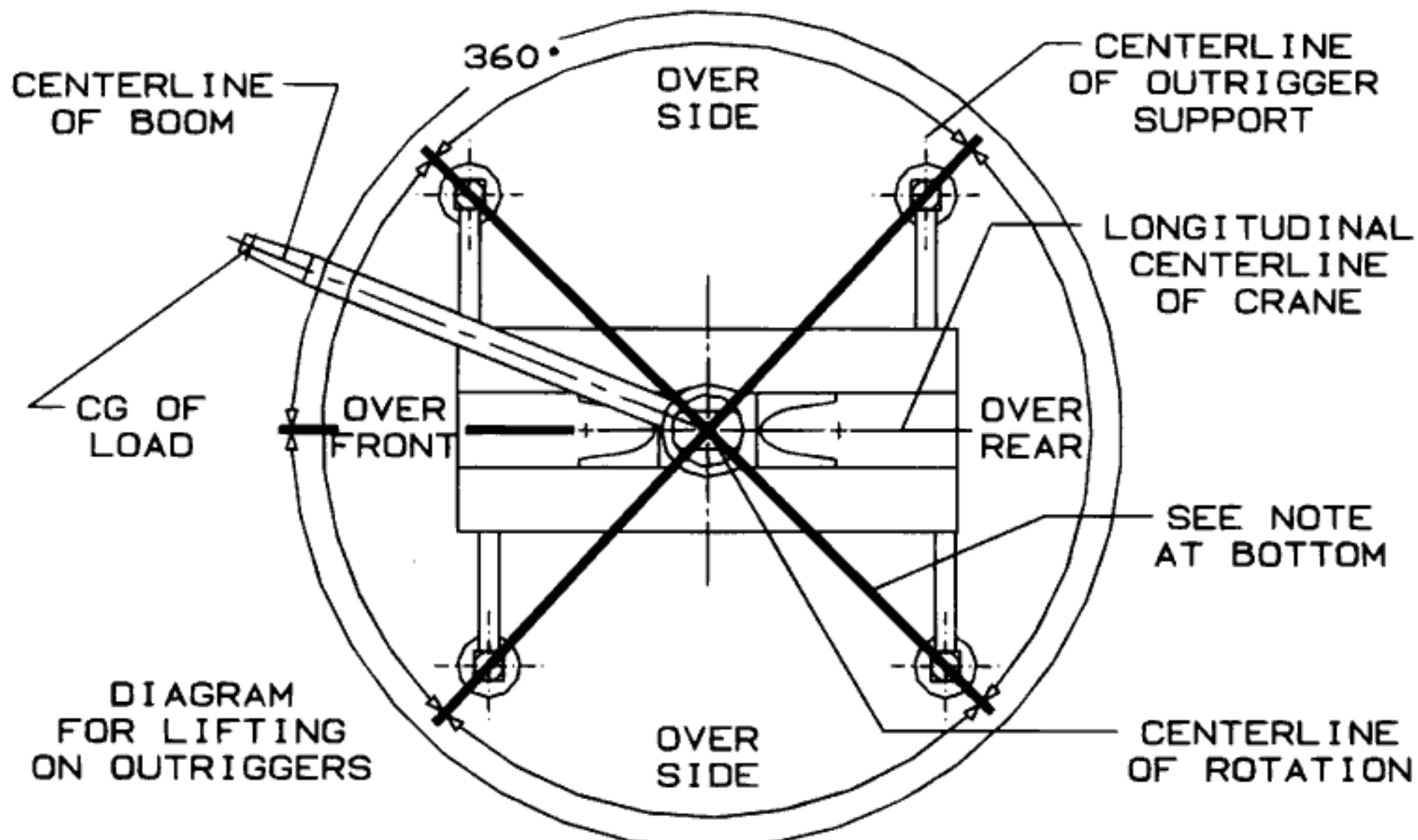

C6-829-003529
C6-829-001159

BOLD LINES DETERMINE THE LIMITING POSITION OF ANY LOAD FOR OPERATION WITHIN WORKING AREAS INDICATED

ZERO DEGREE BOOM ANGLE CHARTS

ON OUTRIGGERS - 360 DEGREES

Boom Angle	Main Boom Length in Feet								
	35	40	50	*60	70	80	90	100	110
0°	15,490 (27.8)	12,240 (33)	7,860 (43)	4,970 (52.8)	3,670 (63)	2,710 (73)	1,960 (83)	1,360 (93)	880 (102.8)

ON RUBBER

Stationary Capacity Defined Arc (3) Over Front

Boom Angle	Main Boom Length in Feet				
	35	40	50	*60	70
0°	13,900 (27.8)	9,660 (33)	4,830 (43)	2,160 (52.8)	1,010 (63)

Stationary Capacity 360° Arc

Boom Angle	Main Boom Length in Feet		
	35	40	50
0°	6,910 (27.8)	4,190 (33)	970 (43)

Pick & Carry Capacities Up to 2.5 MPH Boom Centered (7) Over Front

Boom Angle	Main Boom Length in Feet				
	35	40	50	*60	70
0°	13,900 (27.8)	9,660 (33)	4,830 (43)	2,160 (52.8)	1,010 (63)

A6-829-009334

Note: () Reference radii in feet

*60 ft. boom length is with inner-mid extended and outer-mid & fly ret.

Refer to in-cab load chart for notes.