

GROVE RT600E

product guide

features

- 33-105 ft. (10-32 m) 4-section full power boom
- 29-51 ft. (8.8-15.5 m) telescopic swingaway extension
- Max main boom tip height of 112 ft. (34 m)
- "E" Series cab
- Max overall tip height 162 ft. (49.3 m)
- 40/50 ton (40/45 mt) capacity
- One 2-stage double-acting telescoping cylinder
- 3 position outriggers, max spread 22.5 ft. (6.9 m)
- Cummins QSB 6.7L Tier III, turbocharged diesel engine

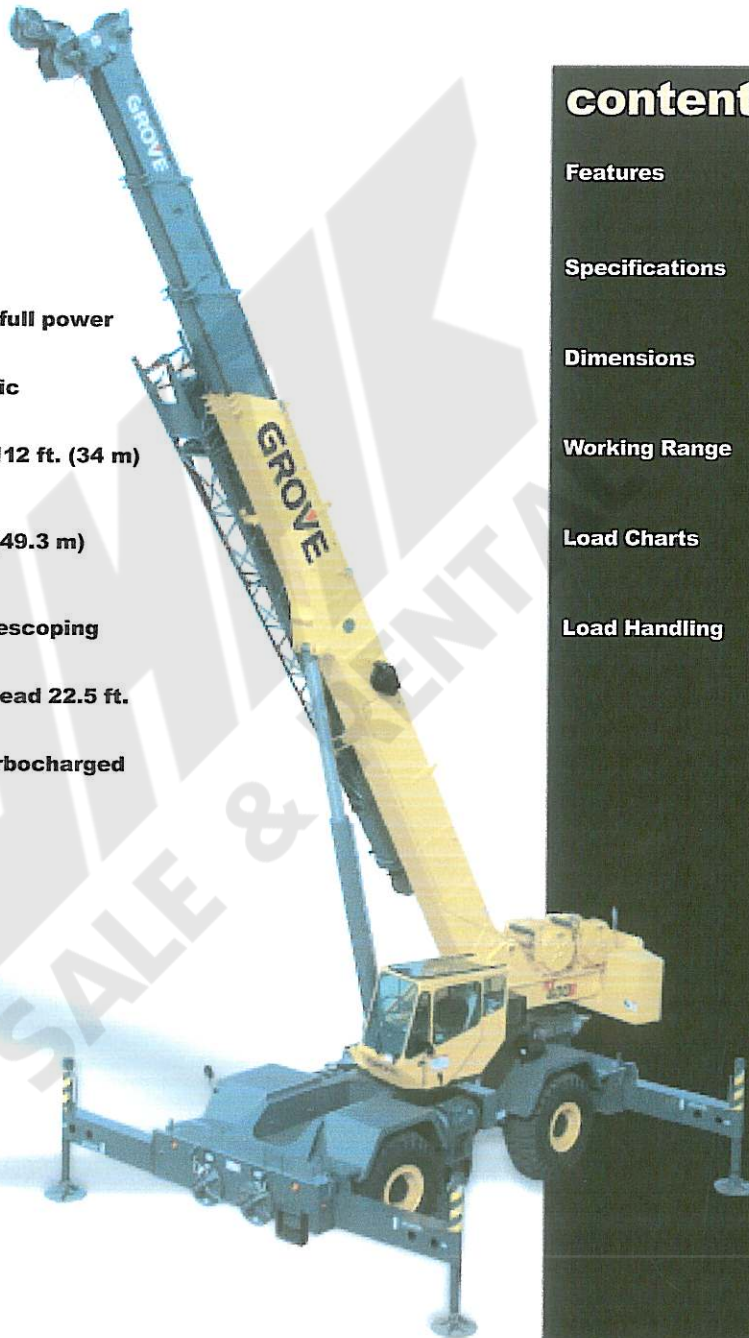

contents

Features	2
Specifications	3
Dimensions	5
Working Range	6
Load Charts	7
Load Handling	11



www.manitowoc.com

Rough Terrain Hydraulic Crane

specifications

Superstructure

Boom

33 ft. - 105 ft. (10.1 m - 32 m) four-section, full-power synchronized boom.
Maximum tip height: 112 ft. (34.1 m).

*Optional Fixed Swingaway Extension

29 ft. (8.8 m) offsettable lattice swingaway extension. Offsettable at 0°, 25° and 45°. Stows alongside base boom section.
Maximum tip height: 141.5 ft. (43.1 m).

*Optional Telescopic Swingaway Extension

29 ft. - 51 ft. (8.8 m - 15.5 m) telescoping lattice swingaway extension. Offsettable at 0°, 25° and 45°. Stows alongside base boom section. Maximum tip height: 162 ft. (49.3 m).

Boom Nose

Three nylatron sheaves mounted on heavy-duty tapered roller bearings with removable pin-type rope guards. Quick-reeve type boom nose.

*Optional removable auxiliary boom nose with removable pin type rope guard.

Boom Elevation

One double-acting hydraulic cylinder with integral holding valve provides elevation from -2° to 78°.

Load Moment & Anti-Two Block System

Standard "Graphic Display" load moment and anti-two block system with audio-visual warning and control lever lockout. These systems provide electronic display of boom angle, length, radius, tip height, relative load moment, maximum permissible load, load indication and warning of impending two-block condition. The system defaults to 360° on rubber chart. The standard Work Area Definition System allows the operator to pre-select and define working areas. If the crane approaches the pre-set limits, audio-visual warnings aid the operator in avoiding job-site obstructions.

Cab

Full vision, all steel fabricated with acoustical lining and tinted safety glass throughout. Deluxe seat incorporates armrest-mounted hydraulic single-axis controllers. Dash panel incorporates gauges for all engine functions. Other standard features include: hot water heater/defroster, cab circulating air fan, sliding side and rear windows, sliding skylight with electric wiper and sunscreen, electric windshield wash/wipe, fire extinguisher, seat belt and circuit breakers.

Swing

Planetary swing with foot-applied multi-disc brake. Spring applied, hydraulically-released swing brake and plunger-type, one position, mechanical house lock operated from cab.
*Optional 360° mechanical swing lock. Maximum speed: 2.5 RPM.

Counterweight

12,250 lbs. (5 556 kg) pinned to superstructure.

Hydraulic System

Three main gear pumps with combined capacity of 103 GPM (391 L/min), 135 GPM (511 L/min) with optional air conditioning. Maximum operating pressure: 3500 psi (26.2 MPa)

Return line type filter with full flow by-pass protection and service indicator. Replaceable cartridge with micron filtration rating of 5/12/16. 134 gallon (509 L) reservoir. Hydraulic oil cooler. System pressure test ports. Manual hyd. pump disconnect.

Hoist Specifications Main and Auxiliary Hoist: Model HP30G

Planetary reduction with automatic spring applied multi-disc brake. Grooved drum. Electronic hoist drum rotation indicator and hoist drum cable followers.

Maximum Single Line Pull:	18,180 lbs (8 246 kg)
Maximum Single Line Speed:	588 FPM (179 m/min)
Maximum Permissible Line Pull:	16,800 lbs. (7 620 kg) w/standard 6 x 37 class rope 16,800 lbs. (7 620 kg) w/optional 35 x 7 class rope
Rope Diameter:	3/4 in. (19 mm)
Rope Length:	450 ft. (137 m)
Rope Type:	6 x 37 Class EIPS IWRC
Optional:	35 x 7 class rotation resistant
Maximum Usable Rope Stowage:	694 ft. (211 m)

RT 600E

GROVE

dimensions

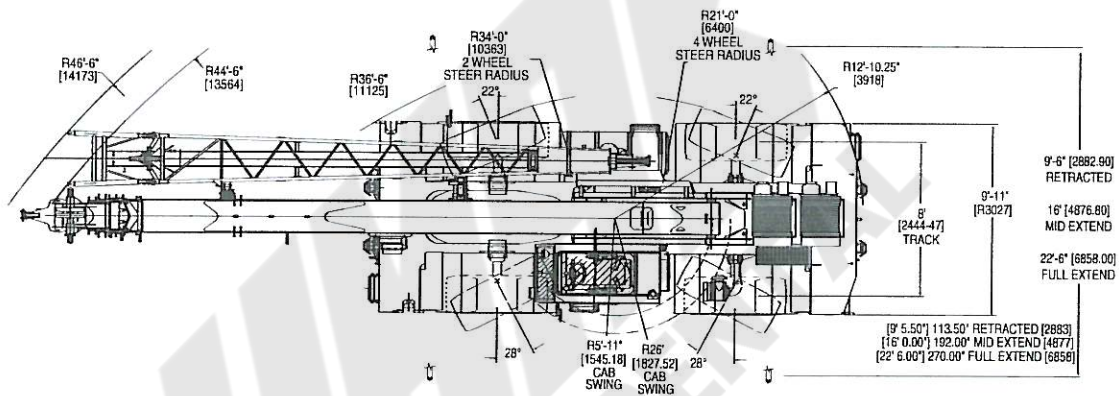
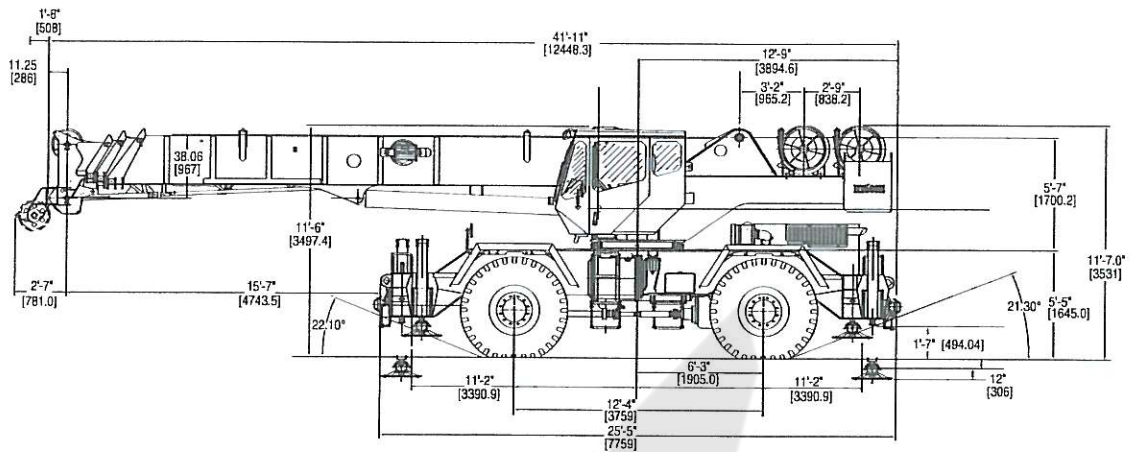

Note: [] Reference dimensions in mm

Weights

	GVW		Front		Rear	
	lb.	kg	lb.	kg	lb.	kg
RT600E Basic Machine	71,691	32,519	32,934	14,939	38,757	17,580
ADD: 29 - 51 ft. tele swingaway	2,109	957	3,456	1,568	-1,347	-611
ADD: 29 ft. swingaway	1,493	677	2,506	1,137	-1,013	-459
ADD: Auxiliary hoist cable	563	255	-213	-97	775	352
ADD: Auxiliary boom nose	131	59	358	162	-227	-103
ADD: 40 ton (35 mt) 3 sheave hookblock (stowed in trough)	800	363	822	373	-22	-10
ADD: 50 ton (45 mt) 3 sheave hookblock (stowed in trough)	1,000	454	1,027	466	-27	-12
ADD: 8.3 ton (7.5 mt) headache ball (hanging from aux. nose)	370	168	643	292	-273	-124
Remove: Counterweight	-11,250	-5,103	4,570	2,073	-15,820	-7,176

working range

Working range - 105 ft. Main Boom

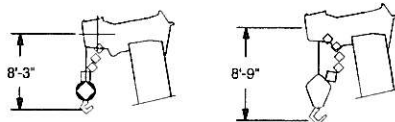
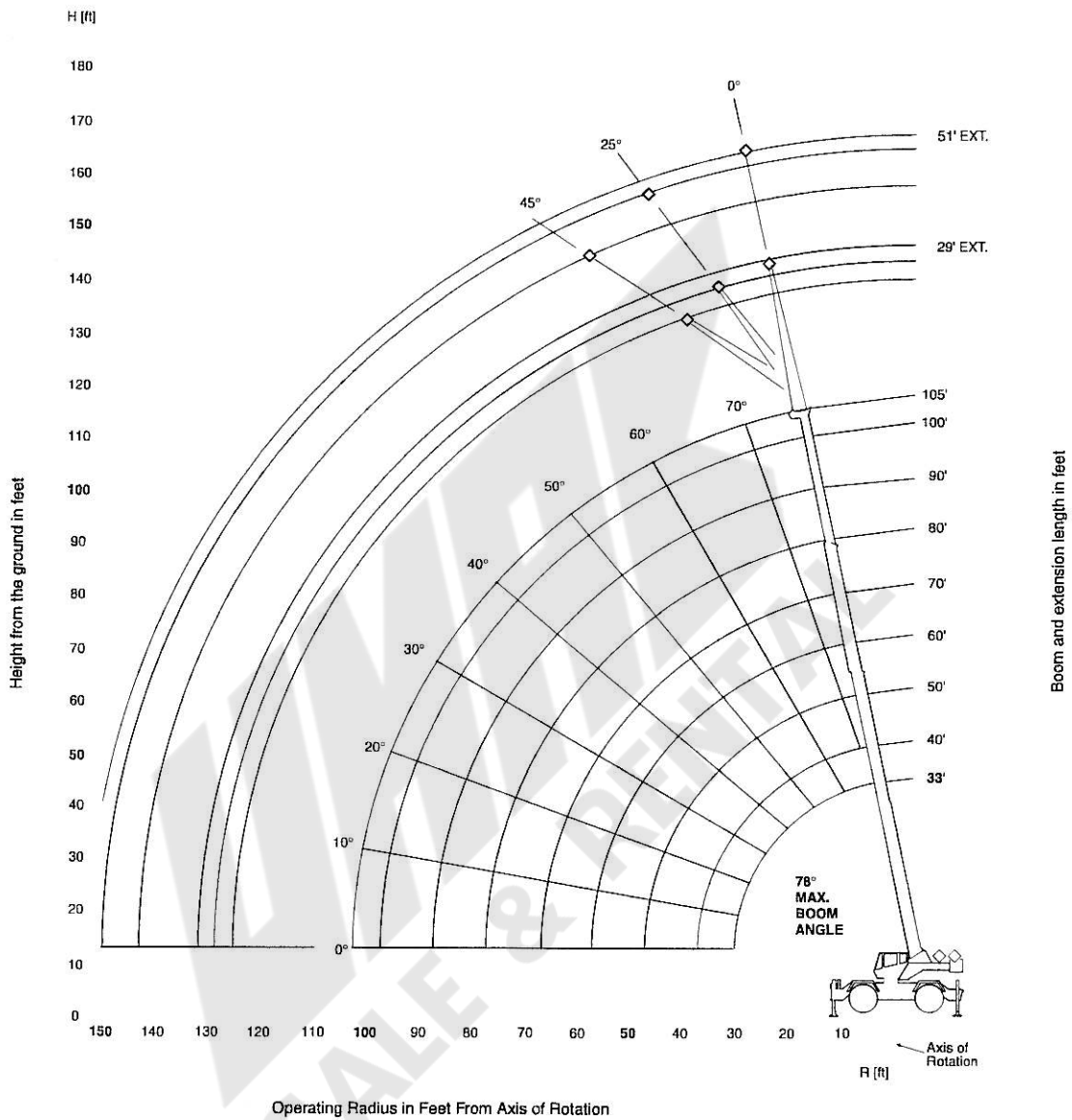

Dimensions are for Largest Grove furnished Hook Block and Headache Ball, with Anti-Two Block Activated.

THIS CHART IS ONLY A GUIDE AND SHOULD NOT BE USED TO OPERATE THE CRANE. The individual crane's load chart, operating instructions and other instructional plates must be read and understood prior to operating the crane.

RT 600E

GROVE

RT650E load chart

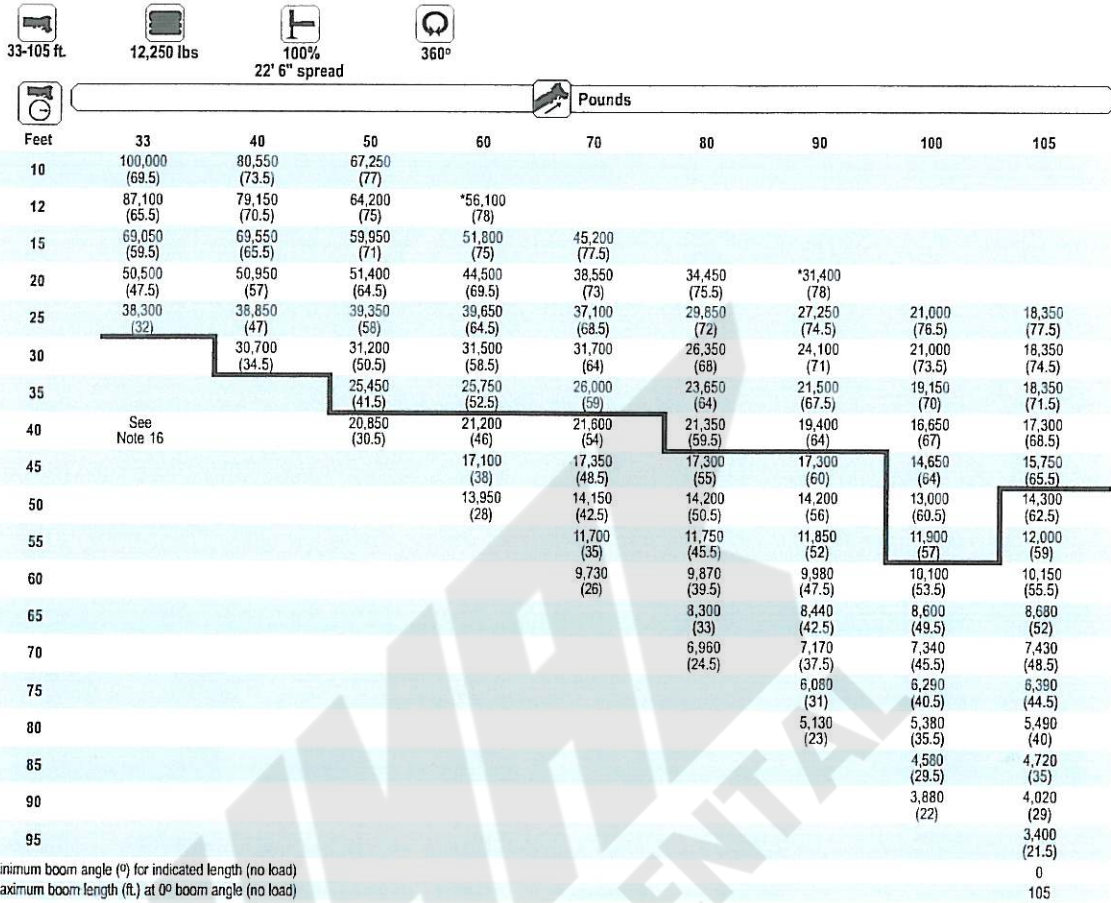

Minimum boom angle (°) for indicated length (no load)
 Maximum boom length (ft.) at 0° boom angle (no load)

NOTE: () Boom angles are in degrees.
 #LMI operating code. Refer to LMI manual for operating instructions.
 *This capacity is based on maximum boom angle.

Lifting Capacities at Zero Degree Boom Angle On Outriggers Fully Extended - 360°

Boom Angle	Main Boom Length in Feet							
	33	40	50	60	70	80	90	100
0°	16,250 (28.2)	12,500 (35)	8,760 (45)	6,290 (55)	4,510 (65)	3,160 (75)	2,110 (85)	1,260 (95)

NOTE: () Reference radii in feet.

A6-829-100936

RT600E

THIS CHART IS ONLY A GUIDE AND SHOULD NOT BE USED TO OPERATE THE CRANE. The individual crane's load chart, operating instructions and other instructional plates must be read and understood prior to operating the crane.

GROVE

Grove RT600E

Product Guide



Features

- 10 m - 32 m (33 ft - 105 ft) four-section full power boom
- 8,8 m – 15,5 m (29 ft – 51 ft) telescopic swingaway extension
- Maximum main boom tip height of 34 m (112 ft)
- Maximum overall tip height of 49,3 m (162 ft)
- 40 t/45 t (40 USt/50 USt) capacity
- Cummins QSB 6.7 L Tier III, turbocharged diesel engine



Features



Cab

The RT600E cab includes:

- hot water heater/defroster
- single axis joystick controllers
- sliding skylight and adjustable sunscreen
- engine instrumentation
- full accoustical lining

The PAT iFlex 5 graphic display LMI includes a work area definition system which allows the operator to define a preferred working area.



Lattice extension

A telescopic swingaway lattice extension easily stows on the side of the base boom for easy transport. With a range of 29 ft - 51 ft the max tip height reaches 162 ft with a capacity of 6000 lb. An optional fixed lattice is also available, reaching a max height of 141 ft.



Stowage

Large open stowage compartment for tools and rigging accessories.

Smooth operation

The RT600E uses a 12,250 lb pinned-on counterweight. Cable power is provided through model HP30A grooved drum hoists with 16,800 lb permissible line pull. Maximum line speed is 588 fpm. Both the main and optional auxiliary hoists have cable capacity up to 694 ft.



Superstructure

The superstructure features a full power four section boom with a four plate rectangular design that can reach to a max tip height of 112 ft. The synchronized extension feature telescopes boom sections at the touch of the hand from an easy to use single lever joystick controller.

Contents

Specifications	4
Dimensions and weights	7
Working range	8
Load charts	9
Load handling	13
Notes	14

UNIMAR
SALE & RENTAL

Specifications

Superstructure

Boom

10,1 m - 32 m (33 ft - 105 ft) four-section, full-power synchronized boom.
Maximum tip height: 34,1 m (112 ft).

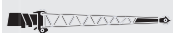

* Optional fixed swingaway extension

8,8 m (29 ft) offsettable lattice swingaway extension. Offsettable at 0°, 25° and 45°. Stows alongside base boom section.

Maximum tip height: 43,1 m (141.5 ft).



* Optional telescopic swingaway extension

8,8 m - 15,5 m (29 ft - 51 ft) telescoping lattice swingaway extension. Offsettable at 0°, 25° and 45°. Stows alongside base boom section.

Maximum tip height: 49,3 m (162 ft).



Boom nose

Three nylatron sheaves mounted on heavy-duty tapered roller bearings with removable pin-type rope guards. Quick-reeve type boom nose.

*Optional removable auxiliary boom nose with removable pin type rope guard.



Boom elevation

One double-acting hydraulic cylinder with integral holding valve provides elevation from -2° to 78°.



Load moment and anti-two block system

Standard “Graphic Display” load moment and anti-two block system with audio-visual warning and control lever lockout. These systems provide electronic display of boom angle, length, radius, tip height, relative load moment, maximum permissible load, load indication and warning of impending two-block condition. The system defaults to 360° on rubber chart. The standard Work Area Definition System allows the operator to pre-select and define working areas. If the crane approaches the pre-set limits, audio-visual warnings aid the operator in avoiding job-site obstructions.



Counterweight

5556 kg (12,250 lb) pinned to superstructure.



Cab

Full vision, all steel fabricated with acoustical lining and tinted safety glass throughout. Deluxe seat incorporates armrest-mounted hydraulic single-axis controllers. Dash panel incorporates gauges for all engine functions. Other standard features include: hot water heater/defroster, air conditioning, cab circulating air fan, sliding side and rear windows, sliding skylight with electric wiper and sunscreen, electric windshield wash/wipe, fire extinguisher, seat belt and circuit breakers.



Swing

Planetary swing with foot-applied multi-disc brake. Spring applied, hydraulically-released swing brake and plunger-type, one position, mechanical house lock operated from cab.

*Optional 360° mechanical swing lock. Maximum speed: 2.5 rpm.



Hydraulic system

Three main gear pumps with combined capacity of 391 L/min (103 GPM), 511 L/min (135 GPM) with optional air conditioning.
Maximum operating pressure: 26.2 MPa (3500 psi)

Return line type filter with full flow by-pass protection and service indicator. Replaceable cartridge with micron filtration rating of 5/12/16. 509 L (134 gal) reservoir. Hydraulic oil cooler. System pressure test ports. Manual hydraulic pump disconnect.



Hoist Specifications (HP30G) main and auxiliary hoist

Planetary reduction with automatic spring applied multi-disc brake. Grooved drum. Electronic hoist drum rotation indicator and hoist drum cable followers.

Maximum single line pull: 8246 kg (18,180 lb)

Maximum single line speed: 179 m/min (588 FPM)

Maximum permissible line pull:
7620 kg (16,800 lb) with standard 6 x 37 class rope
7620 kg (16,800 lb) with optional 35 x 7 class rope

Rope diameter: 19 mm (3/4 in)

Rope length: 137 m (450 ft)

Rope type: 6 x 37 Class EIPS IWRC
Optional rope type: 35 x 7 class rotation resistant

Maximum usable rope stowage: 211 m (694 ft)

Specifications

Carrier



Chassis

Box section frame fabricated from high-strength, low alloy steel. Integral outrigger housings and front/rear lifting, towing, and tie down lugs.



Outrigger system

Four hydraulic telescoping single-stage double box beam outriggers with inverted jacks and integral holding valves. Three position setting. All steel fabricated, quick-release type round outrigger floats, 610 mm (24 in) diameter. Maximum outrigger pad load: 31 344 kg (69,100 lb).



Outrigger controls

Controls and crane level indicator located in cab.



Engine (Tier III)

Cummins QSB 6.7 L diesel, six cylinders, turbocharged, 129 kW (173 bhp) (Gross) @ 2500 rpm. Maximum torque: 800 Nm (590 ft lb) @ 1500 RPM.



Fuel tank capacity

220 L (58 gal)



Transmission

Full powershift with six forward and three reverse speeds. Front axle disconnect for 4 x 2 travel.



Electrical system

Two 12-volt maintenance free batteries. 12-volt starting and lighting, circuit breakers, battery disconnect switch.



Drive

4 x 4



Steering

Fully independent power steering:

Front: Full hydraulic, steering wheel controlled.
Rear: Full hydraulic, switch controlled.

Provides infinite variations of 4 main steering modes: front only, rear only, crab, and coordinated.
“Rear steer centered” indicating light.
4 wheel turning radius - 6,4 m (21 ft)



Axles

Front: Drive/steer with differential and planetary reduction hubs rigid-mounted to frame.

Rear: Drive/steer with differential and planetary reduction hubs pivot-mounted to frame.
Automatic full hydraulic lockouts on rear axle permit oscillation only with boom centered over the front.



Brakes

Full hydraulic split circuit disc-type brakes operating on all wheels. Spring-applied, hydraulically released transmission-mounted parking brake.



Tires

Titan 23.5 x 25 - 20PR bias earthmover type



Lights

Full lighting package including turn indicators, head, tail, brake and hazard warning lights.



Maximum speed

39 km/h (24 mph)



Gradeability (theoretical)

78% (Based on 34 020 kg [75,000 lb] GVW) 23.5 x 25 tires, pumps engaged, 32 m (105 ft) boom, and tele-swingaway.

Specifications

Carrier continued

Miscellaneous standard equipment

Full width steel fenders, dual rear view mirrors, hookblock tiedown, electronic back-up alarm, light package, front stowage well, tachometer, rear wheel position indicator, 36,000 BTU hot water heater, air conditioning, hoist mirrors, engine distress A/V warning system. Auxiliary hoist control valve arrangement (less hoist). Immersion type engine block heater.

* Optional equipment

- ▶ VALUE PACKAGE: includes 8,8 m -15,5 m (29 ft - 51 ft) offsettable telescoping swingaway, 360° NYC style swing lock, and auxiliary hoist package.
- ▶ AUXILIARY HOIST PACKAGE (includes Model HP30G auxiliary hoist with electronic hoist drum rotation indicator, hoist drum cable follower, 137 m (450 ft) of 19 mm (3/4 in) 35 X 7 class wire rope, auxiliary single sheave boom nose.)
- ▶ AUXILIARY LIGHTING PACKAGE: includes cab mounted, 360° rotation spotlight, cab mounted amber flashing light, and dual base boom mounted floodlights, in-cab LMI Light bar, and rubber mat for stowage trough
- ▶ Full-length aluminum decking
- ▶ Pintle hook - rear
- ▶ 360° positive swing lock
- ▶ Cab-controlled cross axle differential lock (front and rear)
- ▶ PAT Event Recorder
- ▶ Third wrap indicator (hoist)
- ▶ Mounting hardware for gooseneck/trailer attachment

Working range

105 ft main boom

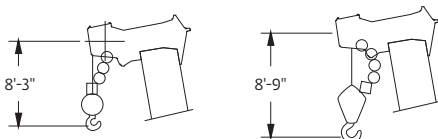
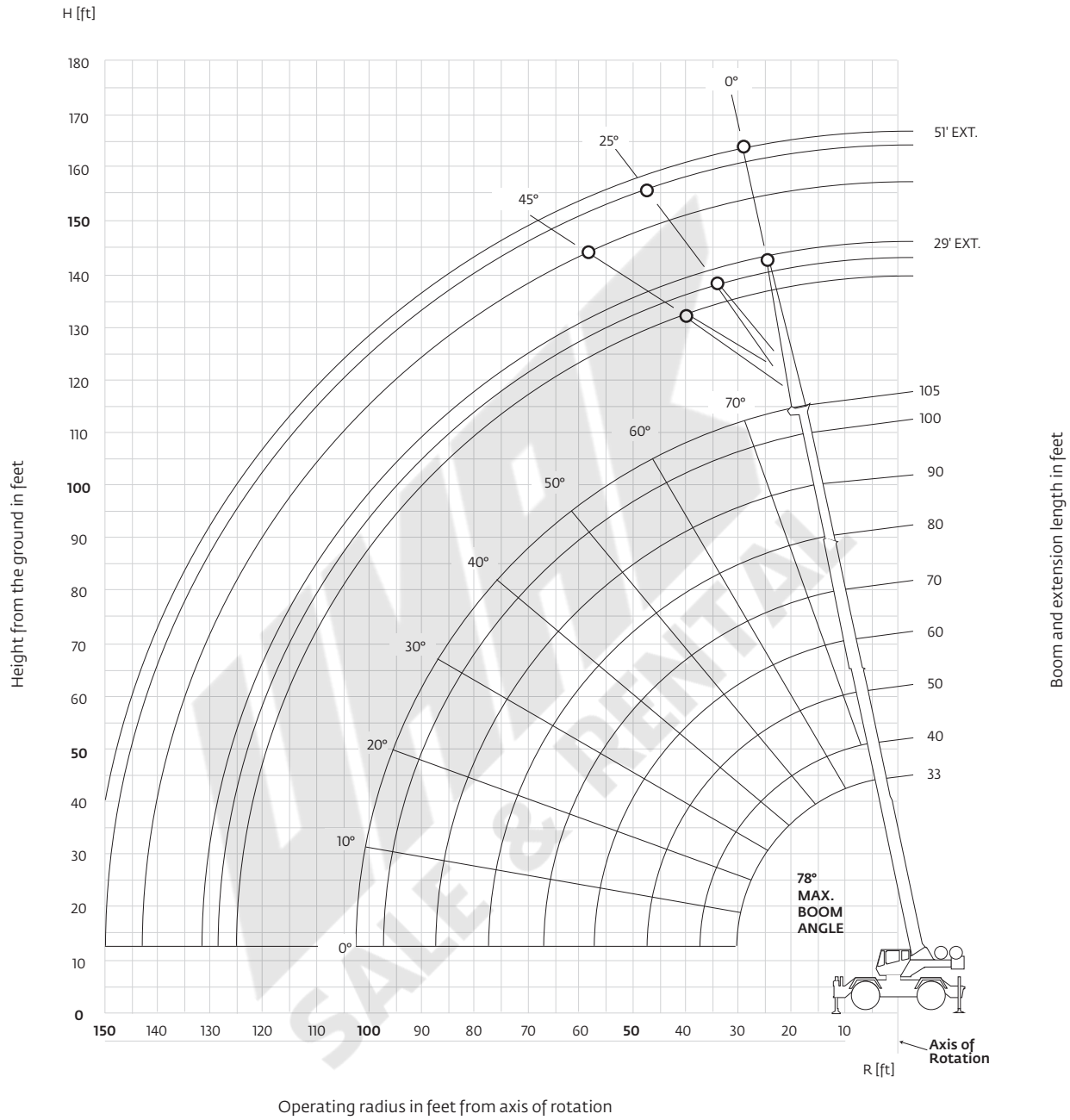

Dimensions are for largest Grove furnished Hook Block and Headache Ball, with Anti-Two Block activated.

THIS CHART IS ONLY A GUIDE AND SHOULD NOT BE USED TO OPERATE THE CRANE.

The individual crane's load chart, operating instructions and other instructional plates must be read and understood prior to operating the crane

Load chart RT650E

 33 ft-105 ft
 12,250 lb
 100%
 360°
 22 ft 6 in spread

Feet	33	40	50	60	70	80	90	100	105
10	100,000 (69.5)	80,550 (73.5)	67,250 (77)						
12	87,100 (65.5)	79,150 (70.5)	64,200 (75)	*56,100 (78)					
15	69,050 (59.5)	69,550 (65.5)	59,950 (71)	51,800 (75)	45,200 (77.5)				
20	50,500 (47.5)	50,950 (57)	51,400 (64.5)	44,500 (69.5)	38,550 (73)	34,450 (75.5)	*31,400 (78)		
25	38,300 (32)	38,850 (47)	39,350 (58)	39,650 (64.5)	37,100 (68.5)	29,850 (72)	27,250 (74.5)	21,000 (76.5)	18,350 (77.5)
30		30,700 (34.5)	31,200 (50.5)	31,500 (58.5)	31,700 (64)	26,350 (68)	24,100 (71)	21,000 (73.5)	18,350 (74.5)
35			25,450 (41.5)	25,750 (52.5)	26,000 (59)	23,650 (64)	21,500 (67.5)	19,150 (70)	18,350 (71.5)
40	See Note 16		20,850 (30.5)	21,200 (46)	21,600 (54)	21,350 (59.5)	19,400 (64)	16,650 (67)	17,300 (68.5)
45				17,100 (38)	17,350 (48.5)	17,300 (55)	17,300 (60)	14,650 (64)	15,750 (65.5)
50				13,950 (28)	14,150 (42.5)	14,200 (50.5)	14,200 (56)	13,000 (60.5)	14,300 (62.5)
55					11,700 (35)	11,750 (45.5)	11,850 (52)	11,900 (57)	12,000 (59)
60					9730 (26)	9870 (39.5)	9980 (47.5)	10,100 (53.5)	10,150 (55.5)
65						8300 (33)	8440 (42.5)	8600 (49.5)	8680 (52)
70						6960 (24.5)	7170 (37.5)	7340 (45.5)	7430 (48.5)
75							6080 (31)	6290 (40.5)	6390 (44.5)
80							5130 (23)	5380 (35.5)	5490 (40)
85								4580 (29.5)	4720 (35)
90								3880 (22)	4020 (29)
95									3400 (21.5)
Minimum boom angle (°) for indicated length (no load)									
									0
Maximum boom length (ft) at 0° boom angle (no load)									
									105
NOTE: () Boom angles are in degrees.									
#LMI operating code. Refer to LMI manual for operating instructions.									
*This capacity is based on maximum boom angle.									
Lifting capacities at zero degree boom angle on outriggers fully extended - 360°									
	Main boom length in feet								
Boom angle	33	40	50	60	70	80	90	100	
0°	16,250 (28.2)	12,500 (35)	8780 (45)	6290 (55)	4510 (65)	3160 (75)	2110 (85)	1260 (95)	

NOTE: () Reference radii in feet.

A6-829-100936

Load chart RT640E





Feet	33	40	50	60	70	80	90	100	105
10	80,000 (69.5)	73,500 (73.5)	67,200 (77)						
12	77,750 (65.5)	69,500 (70.5)	62,300 (75)	*56,100 (78)					
15	69,050 (59.5)	65,550 (65.5)	57,300 (71)	51,800 (75)	45,200 (77.5)				
20	50,500 (47.5)	50,950 (57)	51,400 (64.5)	44,500 (69.5)	38,550 (73)	34,450 (75.5)	*31,400 (78)		
25	38,300 (32)	38,850 (47)	39,350 (58)	39,650 (64.5)	37,100 (68.5)	29,850 (72)	27,250 (74.5)	21,000 (76.5)	18,350 (77.5)
30		30,700 (34.5)	31,200 (50.5)	31,500 (58.5)	31,700 (64)	26,350 (68)	24,100 (71)	21,000 (73.5)	18,350 (74.5)
35			25,450 (41.5)	25,750 (52.5)	26,000 (59)	23,650 (64)	21,500 (67.5)	19,150 (70)	18,350 (71.5)
40	See Note 16		20,850 (30.5)	21,200 (46)	21,600 (54)	21,350 (59.5)	19,400 (64)	16,650 (67)	17,300 (68.5)
45				17,100 (38)	17,350 (48.5)	17,300 (55)	17,300 (60)	14,650 (64)	15,750 (65.5)
50				13,950 (28)	14,150 (42.5)	14,200 (50.5)	14,200 (56)	13,000 (60.5)	14,300 (62.5)
55					11,700 (35)	11,750 (45.5)	11,850 (52)	11,900 (57)	12,000 (59)
60					9730 (26)	9870 (39.5)	9980 (47.5)	10,100 (53.5)	10,150 (55.5)
65						8300 (33)	8440 (42.5)	8600 (49.5)	8680 (52)
70						6960 (24.5)	7170 (37.5)	7340 (45.5)	7430 (48.5)
75							6080 (31)	6290 (40.5)	6390 (44.5)
80							5130 (23)	5380 (35.5)	5490 (40)
85								4580 (29.5)	4720 (35)
90								3880 (22)	4020 (29)
95									3400 (21.5)
Minimum boom angle (°) for indicated length (no load)									0
Maximum boom length (ft) at 0° boom angle (no load)									105

NOTE: () Boom angles are in degrees.
 #LMI operating code. Refer to LMI manual for operating instructions.
 *This capacity is based on maximum boom angle.

Lifting capacities at zero degree boom angle on outriggers fully extended - 360°										
Boom angle	Main boom length in feet									
	33	40	50	60	70	80	90	100	105	
0°	16,250 (28.2)	12,500 (35)	8780 (45)	6290 (55)	4510 (65)	3160 (75)	2110 (85)	1260 (95)		

NOTE: () Reference radii in feet.

A6-829-100832A

Load chart RT600E



Pounds						
Feet	29 ft LENGTH			51 ft LENGTH		
	#0021	#0022	#0023	#0041	#0042	#0043
	0° OFFSET	25° OFFSET	45° OFFSET	0° OFFSET	25° OFFSET	45° OFFSET
30	⁹⁰⁰⁰ (78)					
35	9000 (77)			⁶⁰⁰⁰ (78)		
40	9000 (74.5)	8000 (77.5)		6000 (77)		
45	9000 (72.5)	7560 (76)	⁵⁶⁶⁰ (78)	6000 (76)		
50	8760 (70)	7170 (74)	5600 (76)	6000 (74)		
55	8030 (67.5)	6820 (71.5)	5500 (73.5)	6000 (72)	⁴¹²⁰ (78)	
60	7380 (65)	6500 (69)	5300 (71)	6000 (70)	3900 (77)	
65	6770 (62.5)	6210 (66.5)	5180 (68.5)	6000 (68)	3710 (75)	²⁷⁴⁰ (78)
70	6210 (60)	5950 (64)	4890 (66)	5620 (66)	3530 (72.5)	2660 (76.5)
75	5710 (57.5)	5710 (61.5)	4620 (63)	5210 (64)	3370 (70.5)	2580 (74)
80	5250 (55)	5500 (58.5)	4370 (60.5)	4860 (61.5)	3220 (68.5)	2520 (72)
85	4790 (52)	5300 (56)	4100 (57.5)	4540 (59.5)	3080 (66)	2460 (69.5)
90	4090 (49)	4650 (53)	3820 (54)	4260 (57)	2960 (63.5)	2410 (67)
95	3480 (46)	3960 (49.5)		4000 (55)	2850 (61.5)	2360 (64.5)
100	2930 (42.5)	3350 (46)		3770 (52.5)	2750 (59)	2330 (62)
105	2440 (39)	2810 (42.5)		3360 (50)	2660 (56)	2300 (59)
110	2000 (35)	2320 (38.5)		2910 (47.5)	2570 (53.5)	2280 (56)
115	1610 (30.5)			2500 (44.5)	2500 (50.5)	
120	1250 (25.5)			2120 (41.5)	2430 (47.5)	
125				1780 (38.5)	2250 (44.5)	
130				1470 (35)	1820 (40.5)	
135				1180 (31)	1420 (36.5)	
Min. boom angle for indicated length (no load)	24°	32°	45°	25°	35°	45°
Max. boom length at 0° boom angle (no load)		90 ft		90 ft		

NOTE: () Boom angles are in degrees. A6-829-100845A
 #LMI operating code. Refer to LMI manual for instructions.
 *This capacity based on maximum boom angle.
 **29 ft capacities are also applicable to fixed offsettable ext. However, the LMI codes will change to #0051, #0052 and #0053 for 0°, 25° and 45° offset, respectively.



Pounds					
Feet	#9005				
	Main boom length in feet				
	33	40	50	60	70
10	38,550 (69.5)	38,550 (73.5)			
12	32,550 (65.5)	32,550 (70.5)	32,550 (75)		
15	23,700 (59.5)	23,700 (65.5)	23,700 (71)	23,700 (75)	
20	14,450 (47.5)	14,450 (57)	14,450 (64.5)	14,450 (69.5)	14,450 (73)
25	9640 (32)	9640 (47)	9640 (58)	9640 (64.5)	9640 (68.5)
30		6840 (34.5)	6840 (50.5)	6840 (58.5)	6840 (64)
35			4850 (41.5)	4850 (52.5)	4850 (59)
40			3450 (30.5)	3450 (46)	3450 (54)
45				2410 (38)	2410 (48.5)
50				1610 (28)	1610 (42.5)

Min. boom angle (°) for indicated length (no load) 30
 Max. boom length (ft) at 0° boom angle (no load) 60
 NOTE: () Boom angles are in degrees.
 #LMI operating code. Refer to LMI manual for operating instructions.

Lifting capacities at zero degree boom angle on rubber - 360°			
Boom angle	Main boom length in feet		
	33	40	50
0°	7580 (28.2)	4850 (35)	2410 (45)

NOTE: () Reference radii in feet. A6-829-100836B

NOTES:

- All capacities above the bold line are based on structural strength of boom extension.
 - 29 ft and 51 ft boom extension lengths may be used for single line lifting service.
 - Radii listed are for a fully extended boom with the boom extension erected. For main boom lengths less than fully extended, the rated loads are determined by boom angle. Use only the column which corresponds to the boom extension length and offset for which the machine is configured. For boom angles not shown, use the rating of the next lower boom angle.
- WARNING:** Operation of this machine with heavier loads than the capacities listed is strictly prohibited. Machine tipping with boom extension occurs rapidly and without advance warning.
- Boom angle is the angle above or below horizontal of the longitudinal axis of the boom base section after lifting rated load.
 - Capacities listed are with outriggers fully extended and vertical jacks set.

THIS CHART IS ONLY A GUIDE AND SHOULD NOT BE USED TO OPERATE THE CRANE.

Load charts





Pounds

#9005

Feet	Main boom length in feet				
	33	40	50	60	70
10	46,600 (69.5)	40,800 (73.5)	34,600 (77)		
12	40,800 (65.5)	40,800 (70.5)	34,600 (75)		
15	34,000 (59.5)	34,000 (71)	34,000 (71)	26,650 (75)	21,500 (77.5)
20	26,050 (47.5)	26,050 (57)	26,050 (64.5)	26,050 (69.5)	21,500 (73)
25	18,200 (32)	18,200 (47)	18,200 (58)	18,200 (64.5)	18,200 (68.5)
30		13,100 (34.5)	13,100 (50.5)	13,100 (58.5)	13,100 (64)
35			10,050 (41.5)	10,050 (52.5)	10,050 (59)
40			7900 (30.5)	7900 (46)	7900 (54)
45				6290 (38)	6290 (48.5)
50				5050 (28)	4940 (42.5)
55					4060 (35)
60					3260 (26)

Min. boom angle (°) for indicated length (no load) 0
 Max. boom length (ft) at 0° boom angle (no load) 70
 NOTE: () Boom angles are in degrees.
 #LMI operating code. Refer to LMI manual for operating instructions.

Lifting capacities at zero degree boom angle on rubber - Defined arc over front

Boom angle	Main boom length in feet				
	33	40	50	60	70
0°	14,550 (28.2)	10,050 (35)	6290 (45)	4060 (55)	2590 (65)

NOTE: () Reference radii in feet. A6-829-100835B





Pounds

#9006

Feet	Main boom length in feet				
	33	40	50	60	70
10	30,150 (69.5)	30,150 (73.5)	17,850 (77)		
12	30,150 (65.5)	30,150 (70.5)	17,850 (75)		
15	29,650 (59.5)	29,650 (65.5)	17,850 (71)	17,850 (75)	14,750 (77.5)
20	22,650 (47.5)	22,650 (57)	17,850 (64.5)	17,850 (69.5)	14,750 (73)
25	17,850 (32)	17,850 (47)	17,850 (58)	17,850 (64.5)	14,750 (68.5)
30		13,100 (34.5)	13,100 (50.5)	13,100 (58.5)	13,100 (64)
35			10,050 (41.5)	10,050 (52.5)	10,050 (59)
40			7340 (30.5)	7340 (46)	7340 (54)
45				6020 (38)	6020 (48.5)
50				4940 (28)	4940 (42.5)
55					4030 (35)
60					3260 (26)

Min. boom angle (°) for indicated length (no load) 0
 Max. boom length (ft) at 0° boom angle (no load) 70
 NOTE: () Boom angles are in degrees.
 #LMI operating code. Refer to LMI manual for operating instructions.

Lifting capacities at zero degree boom angle on rubber - Pick & carry

Boom angle	Main boom length in feet				
	33	40	50	60	70
0°	14,550 (28.2)	10,050 (35)	6020 (45)	4030 (55)	2590 (65)

NOTE: () Reference radii in feet. A6-829-100837B

SALE & RENT

Load handling

Weight reductions for load handling devices

29 ft offsettable boom extension	Pounds
*Erected –	4412
29 ft 51 ft tele. boom extension	Pounds
*Erected (retracted) –	6611
*Erected (extended) –	9332
*Reduction of main boom capacities	
Auxiliary boom nose	Pounds
	137
Hookblocks and headache balls	Pounds
50 USt, 4-sheave	1075
50 USt, 3-sheave	1000
40 USt, 3-sheave	800
8.3 USt headache ball (non-swivel)	350
8.3 USt headache ball (swivel)*	370
+Refer to rating plate for actual weight.	

When lifting over swingaway and/or jib combinations, deduct total weight of all load handling devices reeved over main boom nose directly from swingaway or jib capacity.

NOTE: All load handling devices and boom attachments are considered part of the load and suitable allowances **MUST BE MADE** for their combined weights. Weights are for Grove furnished equipment.

Reeving diagram

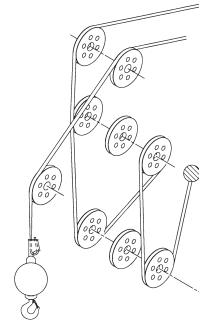

Line pulls and reeving information

Hoists	Cable specs	Permissible line pulls	Nominal cable length
Main	19 mm (3/4 in) 6 x 37 class, EIPS, IWRC Special Flexible Min. Breaking Str. 58,800 lb	16,800 lb	450 ft
Main and auxiliary	19 mm (3/4 in) Flex-X 35 Rotation resistant (non-rotating) Min. breaking Str. 85,800 lb	16,800 lb	450 ft

The approximate weight of 3/4 in wire rope is 1.5 lb/ft

Hoist performance

Wire rope layer	Hoist line pulls two-speed hoist		Drum rope capacity (ft)	
	Low available lb ^o	High available lb ^o	Layer	Total
1	18,134	9067	101	101
2	16,668	8334	110	211
3	15,420	7710	120	331
4	14,347	7174	129	460
5	13,413	6707	139	599
6	12,594	6297	149	748

^o Max lifting capacity:

6 x 37 class or 35 x 7 class = 16,800 lb

Working area diagram

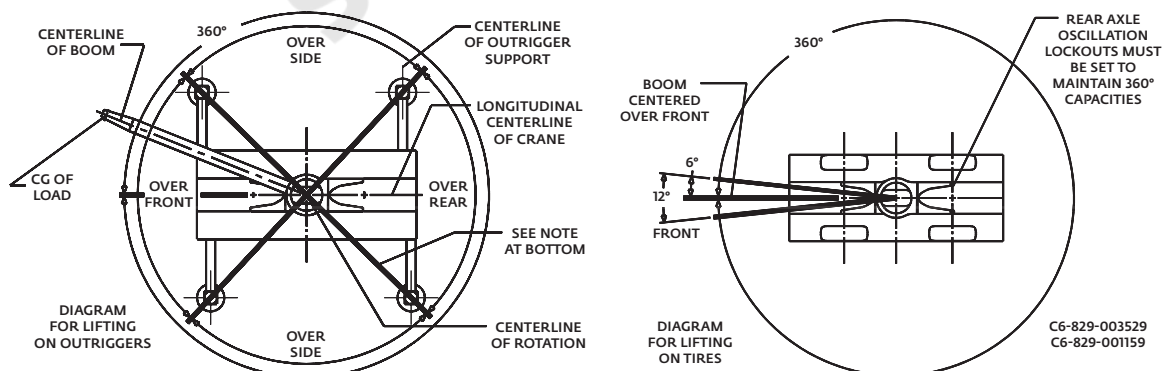

Bold lines determine the limiting position of any load for operation within working areas indicated.

Notes

UMAX
SALE & RENTAL



Regional headquarters

Manitowoc - Americas

Manitowoc, Wisconsin, USA

Tel: +1 920 684 6621

Fax: +1 920 683 6277

Shady Grove, Pennsylvania, USA

Tel: +1 717 597 8121

Fax: +1 717 597 4062

Manitowoc - Europe, Middle East & Africa

Ecully, France

Tel: +33 (0)4 72 18 20 20

Fax: +33 (0)4 72 18 20 00

Manitowoc - Asia Pacific

Shanghai, China

Tel: +86 21 6457 0066

Fax: +86 21 6457 4955

Regional offices

Americas

Brazil

Alphaville

Mexico

Monterrey

Chile

Santiago

Europe, Middle East & Africa

Algeria

Hydra

Czech Republic

Netvorice

France

Baudemont

Cergy

Decines

Germany

Langenfeld

Hungary

Budapest

Italy

Parabiago

Netherlands

Breda

Poland

Warsaw

Portugal

Baltar

Lisbon

Russia

Moscow

U.A.E.

Dubai

U.K.

Gawcott

Asia - Pacific

Australia

Brisbane

Melbourne

Sydney

China

Beijing

Xi'an

India

Hyderabad

Pune

Korea

Seoul

Philippines

Makati City

Singapore

Factories

Brazil

Alphaville

China

TaiAn

Zhangjiagang

France

Charlieu

La Clayette

Moulins

Germany

Wilhelmshaven

India

Pune

Italy

Niella Tanaro

Portugal

Baltar

Fânzeres

Slovakia

Saris

USA

Manitowoc

Port Washington

Shady Grove

This document is non-contractual. Constant improvement and engineering progress make it necessary that we reserve the right to make specification, equipment, and price changes without notice. Illustrations shown may include optional equipment and accessories and may not include all standard equipment.