

MODEL 36

6-7½ TON
CAPACITY
5.5-6.8 metric tons

INDUSTRIAL YARD CRANE



- **LOW PROFILE** . . . only 8' (2.44m) high, the Grove Model 36 is ideal for close quarter operation, in plant or outside storage yard. Counterweight swing is only 4' (1.22m) and entirely within machine perimeter.
- **POWER-TELESCOPING BOOMS** . . . 3-boom lengths available – 20', 30' and 42' (6.1m, 9.14m and 12.8m) – providing up to 40' (12.2m) of horizontal reach and a maximum tip height of 49' (14.93m).
- **SWING** . . . 140°, 260°, or 360° continuous swing available.
- **PICK & CARRY CAPACITY** . . . 12,000 lbs. (5 443kg) over the front.
- **CARRY DECK** . . . 65 sq. ft. (6.04m²) front and side carry deck will accommodate many hard-to-handle shapes.



**HYDRAULIC
CRANES**



MODEL 36

SUPERSTRUCTURE SPECIFICATIONS

STANDARD EQUIPMENT

BOOM - 14 ft. - 22 ft. (4.27m - 6.71m), 2-section, full power telescoping.
BOOM HEAD - Single sheave; root diameter 9 $\frac{1}{8}$ " (251mm); flange diameter 12" (305mm).
BOOM ELEVATION - Twin double-action cylinders (power up, power down) 7" diameter (178mm); integral holding valves; boom angle range: 0° to 75°; pendulum-type angle indicator.
WINCH - Braden Model PD10-77, power up and down, equal speed both directions; Planetary Drive with integral automatic brake; 125 ft. (38.1m) of $\frac{1}{2}$ in. (13mm) cable; 6 x 25 EIPS, Type W construction. Drum: 9 $\frac{1}{2}$ in. (241mm) diameter, 12 $\frac{3}{4}$ in. (324mm) wide, 16 in. (406mm) flange diameter.
SINGLE LINE SPEEDS -

| | FULL LOAD | NO LOAD |
|-----------|--------------------|--------------------|
| Bare Drum | 100 FPM (30.48MPM) | 135 FPM (41.15MPM) |
| Mean Drum | 120 FPM (36.58MPM) | 165 FPM (50.29MPM) |
| Full Drum | 160 FPM (48.77MPM) | 220 FPM (67.06MPM) |

SINGLE LINE PULL -
 Bare Drum - 9,000 lbs. (4 082kg)
 Mean Drum - 7,499 lbs. (3 402kg)
 Full Drum - 5,625 lbs. (2 552kg)
DRUM CAPACITY - 490 ft. of $\frac{1}{2}$ in. cable (149.35m of 13mm).
BOOM SPEEDS - Out, 16 seconds; in, 13 seconds; up, 22 seconds; down, 20 seconds.
SWING - 140° rotation, ball bearing swing circle, hydraulic motor powered; speed: 3 $\frac{3}{4}$ RPM. Non-free swing, automatic swing brake.

HYDRAULIC PUMP - 2-section; volumes calculated at 2400 RPM and 500 PSI (35.2 kg/cm²). Main section for craning functions: 44.5 GPM (168 LPM); second section for steering: 16 GPM (61 LPM). Total capacity: 60.5 GPM (229 LPM).

CRANE CONTROLS - Four-way double acting hydraulic valves; integral main by-pass for system relief; individual by-pass for circuit relief.

OPERATING PRESSURE - 2250 PSI (158 kg/cm²), crane functions; 1250 PSI (87.9 kg/cm²), steering.

HYDRAULIC OIL RESERVOIR - 50-gallon (189 liters) capacity with return line filter.

SUPERSTRUCTURE - Optional equipment

BOOMS - 14 ft. - 30 ft. (4.27m - 9.14m), 3-section, full power; 18 ft. - 42 ft. (5.49m - 12.8m), 3-section, full power.

JIB - 14 ft. (4.27m) non-stowable.

HOOK BLOCK - 8-ton (7.2m) single sheave with ball bearing swivel hook. 3-ton (2.7m) overhaul ball and swivel hook.

ROTATION - 260° swing - similar to 140° swing with stops placed to permit 260° rotation. Standard option is 130° right and left from center over front, but requires optional outriggers. 360° continuous swing - includes hydraulic swivel to permit continuous rotation in either direction, also requires 4 outriggers.

FLOODLIGHT, boom-mounted - Unit swivel-mounted on base section of boom; off-on switch controlled from cab. 12V, 1000 candlepower.

CHASSIS SPECIFICATIONS

STANDARD EQUIPMENT

FRAME - High-strength steel, all-welded reinforced construction.

CARRY-DECK - Steel "Tread-Plate" welded to frame. Load area: 65 sq. ft. (6.04m²). Maximum loading: 125 lbs./sq. ft. (610 kg/m²). Combined hook and deck load not to exceed 12,000 lbs. (5 443kg).

ENGINE DATA

| | STANDARD |
|-------------------|-------------------------------------|
| MAKE | Ford 300 |
| TYPE | 4-cycle gasoline |
| CYLINDERS | 6 |
| BORE & STROKE | 4.00 x 3.98 in. (102mm x 101mm) |
| DISPLACEMENT | 300 cu. in. (4916cm ³) |
| NET H.P. | 118 @ 2800 RPM |
| NET TORQUE | 222 lbs. ft. @ 2800 RPM |
| GOVERNED RPM | 2800 |
| COOLING SYSTEM | Liquid, 26 qt. (24 liters) capacity |
| FUEL CAPACITY | 50 gal. (189 liters) w/Protecto Cap |
| ELECTRICAL SYSTEM | 12 volt |
| ALTERNATOR | 30 amp |
| BATTERY | 66 plate, 62 amp hr. |

TRANSMISSION - Manual shift, 4 speeds forward and 4 reverse; helical gear, synchronized in top 3 speeds; spur gear provided in low. Dry type disc clutch.

DRIVE SHAFT - Heavy-duty industrial type with double universal joints.

AXLES - FRONT DRIVE AXLE, Hypoid single reduction, REAR STEER AXLE, wide-track; axle oscillation 0 to 10 in. (0 to 254mm).

OSCILLATION LOCKOUTS - Automatic on rear axle.

STEERING - Hydraulic, full power on rear wheels. Failsafe feature when power source is lost.

BRAKES - Service: power-assist hydraulic on front wheels. Drum and Shoe type, 156 sq. in. (1006cm²) lining. Drum diameter 16.5 in. x 5 in. (419mm x 127mm).

Parking: Mechanical, mounted on drive shaft. Hand lever controlled. Adjustment on hand lever.

TIRES - Front: (4) 10:00 x 20 - 12 ply

Rear: (2) 10:00 x 20 - 12 ply

CHASSIS CONTROLS - All basic controls with engine instruments, including hourmeter and electric fuel gauge.

WEIGHT - Basic machine: 22,510 lbs. (10 210kg)

14 ft. - 30 ft. (4.27m - 9.14m) boom add 1,100 lbs. (499kg)

18 ft. - 42 ft. (5.49m - 12.8m) boom add 2,300 lbs. (1 043kg)

Enclosed cab add 300 lbs. (136kg)

360° rotation add 100 lbs. (45kg)

Front outriggers add 1,850 lbs. (839kg)

Front and rear outriggers add 1,900 lbs. (862kg)

WEIGHT DISTRIBUTION - 12,400 lbs. (5 625kg) on front axle; 10,100 lbs. (4 581kg) on rear axle. (Boom and front outrigger weights affect front axle loading. If equipped with rear outriggers, rear counterweight is omitted.)

PERFORMANCE - STANDARD ENGINE & TRANSMISSION

Axle ratio: 6.167:1 Auxiliary Gear Box: 2.41:1

| Gear Range | Ratio | Speed (MPH) | Drawbar Pull (lbs.) | % Gradeability |
|------------|---------|--------------------|---------------------|----------------|
| 1st | 6.324:1 | 3.5 (5.6 KPH) | 6,950 (3 152kg) | 26.0 |
| 2nd | 3.092:1 | 7.2 (11.6 KPH) | 4,802 (2 178kg) | 17.8 |
| 3rd | 1.686:1 | 13.2 (21.2 KPH) | 2,413 (1 094kg) | 8.8 |
| 4th | 1.000:1 | 22.2 (35.7 KPH) | 1,248 (566kg) | 4.4 |

NOTE: Speed and gradeability performance measured on concrete. Maximum drawbar pull and gradeability limited by torque required to slip wheels.

DIMENSIONAL CHARTS

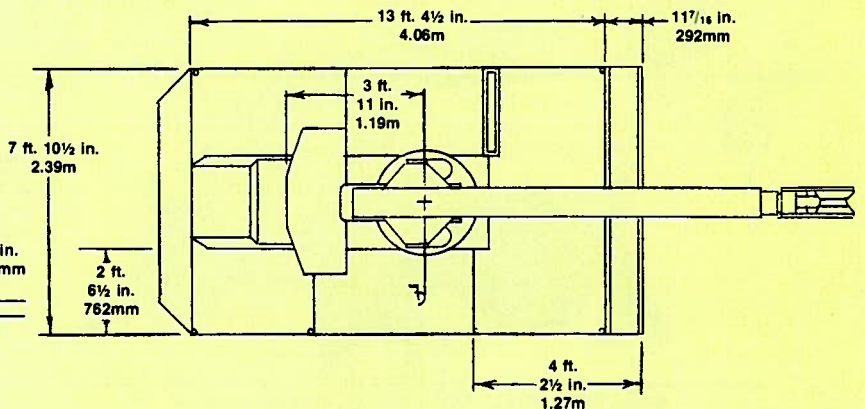
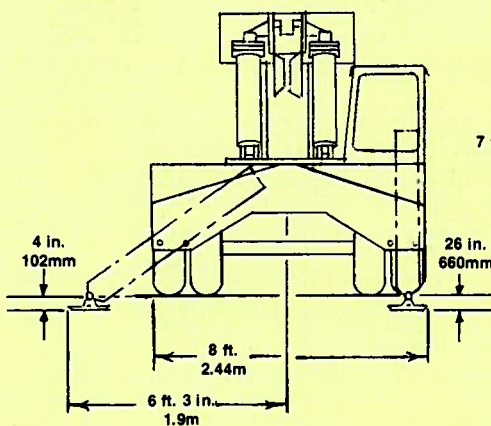
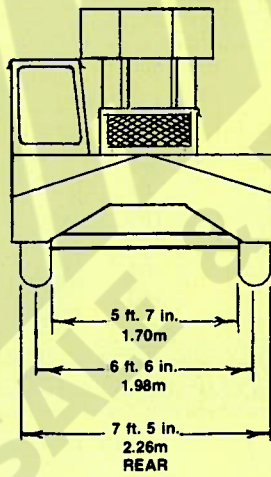
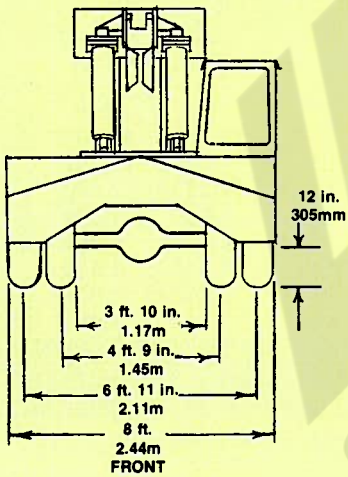
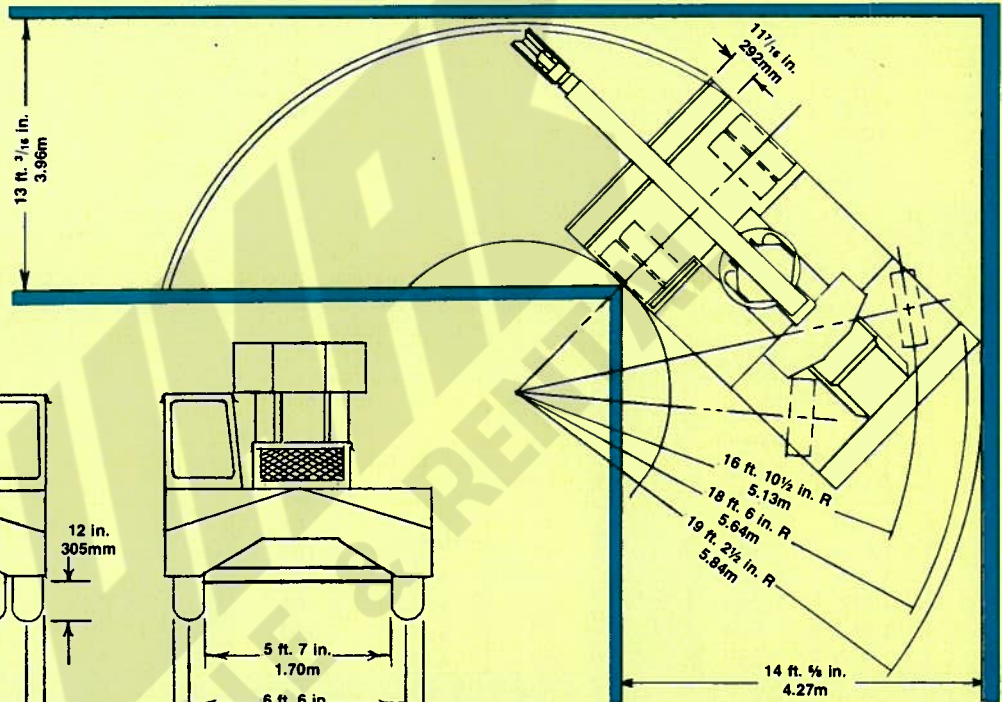
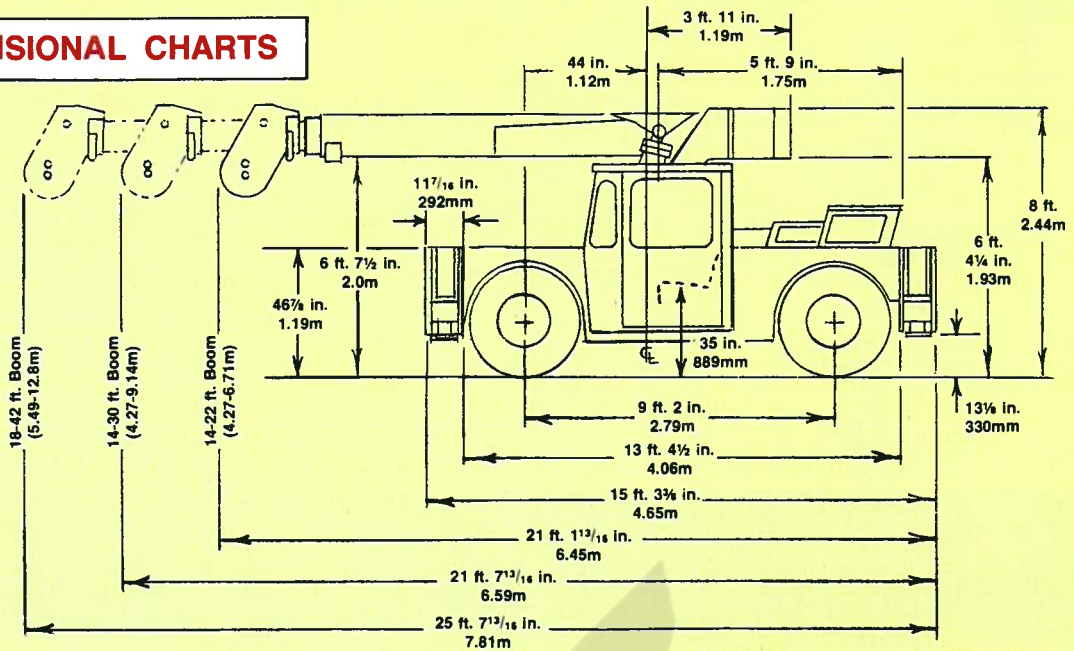



MODEL 36

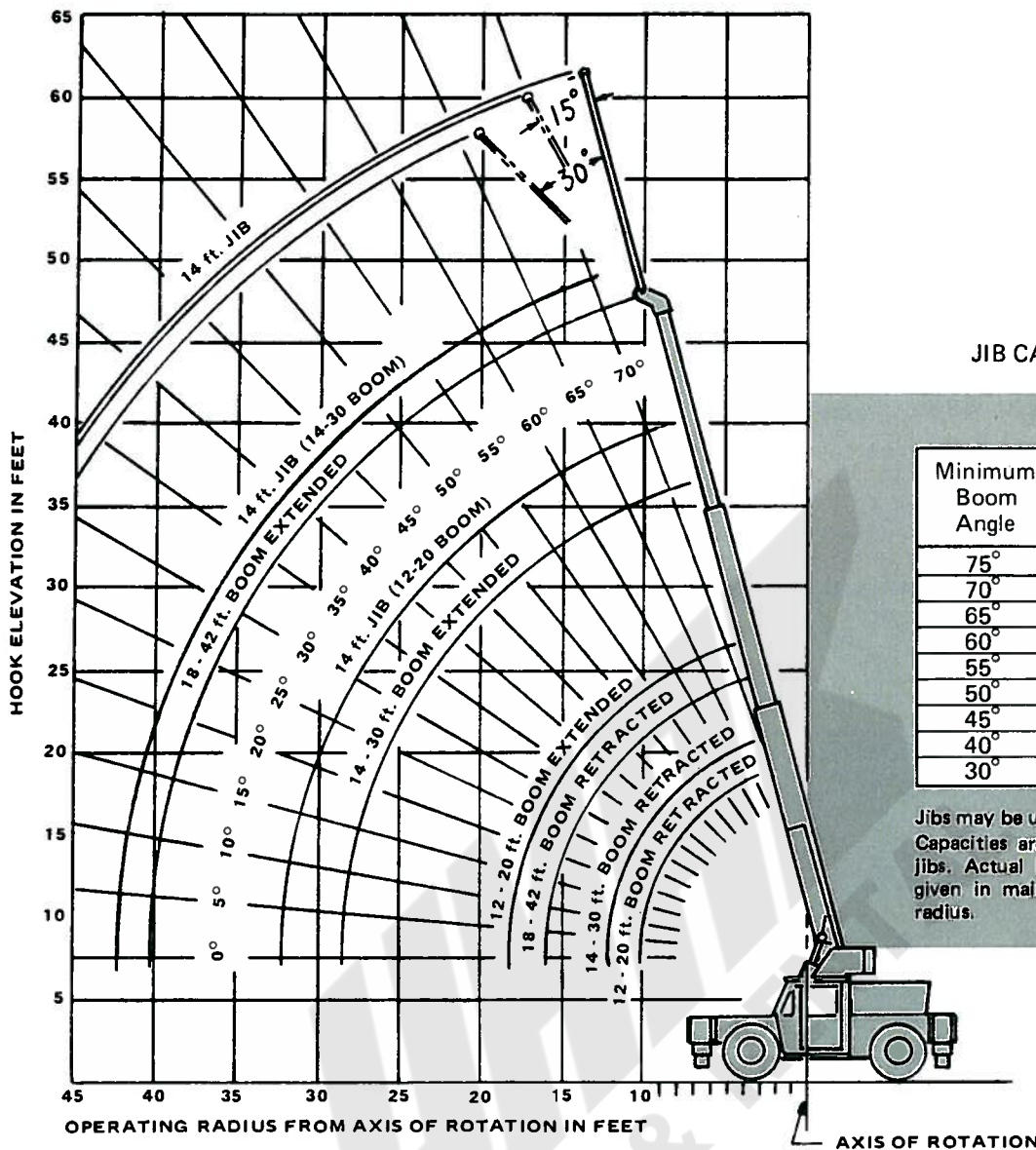

JIB CAPACITIES IN POUNDS

| Minimum Boom Angle | No Offset | Maximum Offset (30°) |
|--------------------|-----------|----------------------|
| 75° | 6,200 | 2,600 |
| 70° | 5,000 | 2,400 |
| 65° | 4,300 | 2,300 |
| 60° | 3,700 | 2,150 |
| 55° | 3,300 | 2,100 |
| 50° | 2,600 | 1,650 |
| 45° | 2,400 | 1,500 |
| 40° | 2,200 | 1,460 |
| 30° | 1,900 | 1,200 |

Jibs may be used with single part line only. Capacities are based on structural strength of jibs. Actual loads must not exceed capacities given in main boom chart for same working radius.

CHASSIS - Optional Equipment

ENGINE DATA

OPTIONAL
 MAKE Detroit Diesel 3-53N
 TYPE 2-cycle diesel
 CYLINDERS 3
 BORE & STROKE 3.875 x 4.50 in. (98mm x 114mm)
 DISPLACEMENT 159 cu. in. (2606cm³)
 NET H.P. 83 @ 2800 RPM
 NET TORQUE 156 lbs. ft. @ 2800 RPM
 GOVERNED RPM 2800
 COOLING SYSTEM Liquid, 28½ qt. (27 liters) capacity
 FUEL CAPACITY 50 gal. (189 liters) w/Protecto Cap
 ELECTRICAL SYSTEM 12 volt
 ALTERNATOR 55 amp
 BATTERY 150 plate, 204 amp hr.

TRANSMISSION - Power shift, forward-reverse with Torque Converter, manual speed selection; 4 speeds forward and 4 speeds reverse.

LIMITED SLIP DIFFERENTIAL - Same as standard except for limited slip feature.

LP (Liquid Propane) GAS SYSTEM - Liquid withdrawal.

TIRES - 9.00 x 20 - Michelin

CAB - Steel construction, fully-enclosed; weatherstripped, safety glass windows, windshield, skylight and left-hand door; electric windshield wiper and cab heater.

DEFROSTER - Electric fan.

LIGHTS - Group 1 - Head, tail, stop and back-up. Group 2 - Head, tail, stop, back-up, 4-way flasher and turn signal.

PINTLE HOOK (Front) - Flush-mounted.

PINTLE HOOK (Rear) - Flush-mounted.

TOWING WINCH - Front-mounted; 9,000 lbs. (4 082kg) capacity.

OUTRIGGERS - Hydraulic with integral safety holding valves. Oblique and vertical operation positions. Individually-controlled from Operator's position.

- (1) Front outriggers only - 140° swing
- (2) Front and rear outriggers - 260° swing
- (3) Front and rear outriggers - 360° swing

CARRY-DECK POSTS - Set of five.

ELECTRONIC AUDIO BACK-UP ALARM

Constant improvement and engineering progress make it necessary that we reserve the right to make specification, equipment, and price changes without notice.

MODEL 36 RATED LIFTING CAPACITIES

14 ft. - 22 ft. BOOM

FRONT OUTRIGGERS
FULLY SPREAD
140° SWING

ON RUBBER
140° SWING

| Radius in Feet | On Rubber | |
|----------------|-----------|----------|
| | Front | Side 70° |
| 10 | 12,000 | 8,750 |
| 12 | 10,250 | 6,300 |
| 15 | 6,650 | 4,200 |
| 19 | 4,450 | 3,050 |

| Radius in Feet | With Outriggers | |
|----------------|-----------------|----------|
| | Front | Side 70° |
| 10 | 15,000 | 15,000 |
| 12 | 14,000 | 12,300 |
| 15 | 12,750 | 8,400 |
| 19 | 9,600 | 5,750 |

PICK & CARRY

**6 TON
CAPACITY**
(5.5 metric tons)

WITH OUTRIGGERS

**7½ TON
CAPACITY**
(6.8 metric tons)

14 ft. - 30 ft. BOOM

FRONT OUTRIGGERS
FULLY SPREAD
140° SWING

ON RUBBER
140° SWING

| Radius in Feet | On Rubber | |
|----------------|-----------|--------|
| | Front | Side** |
| 10 | 12,000 | 8,100 |
| 12 | 9,200 | 5,800 |
| 15 | 6,600 | 4,000 |
| 20 | 4,250 | 2,500 |
| 25 | 3,000 | 1,650 |
| 28 | 2,500 | 1,350 |

| Radius in Feet | With Outriggers | |
|----------------|-----------------|-----------|
| | Front | Side 70°* |
| 10 | 15,000 | 15,000 |
| 12 | 14,000 | 12,000 |
| 15 | 12,750 | 8,400 |
| 20 | 9,000 | 5,400 |
| 25 | 6,200 | 3,800 |
| 28 | 5,100 | 3,200 |

FRONT & REAR OUTRIGGERS
FULLY SPREAD
260° & 360° SWING

| Radius in Feet | With Outriggers | |
|----------------|-----------------|--------|
| | Front | 360°* |
| 10 | 15,000 | 15,000 |
| 12 | 14,000 | 14,000 |
| 15 | 12,750 | 12,750 |
| 20 | 9,000 | 7,000 |
| 25 | 6,200 | 4,800 |
| 28 | 5,100 | 4,000 |

18 ft. - 42 ft. BOOM

FRONT OUTRIGGERS
FULLY SPREAD
140° SWING

ON RUBBER
140° SWING

| Radius in Feet | On Rubber | |
|----------------|---------------------|--------|
| | Front | Side** |
| 10 | 12,000 ³ | 7,250 |
| 12 | 9,200 | 5,200 |
| 15 | 6,500 | 3,750 |
| 20 | 3,650 | 2,500 |
| 25 | 2,500 | 1,650 |
| 30 | 1,950 | 1,200 |
| 35 | 1,350 | 650 |
| 40 | 900 | 350 |

| Radius in Feet | With Outriggers | |
|----------------|---------------------|---------------------|
| | Front | Side 70°* |
| 10 | 15,000 ¹ | 12,000 ³ |
| 12 | 14,000 ² | 8,650 |
| 15 | 12,000 ³ | 5,100 |
| 20 | 9,000 | 3,700 |
| 25 | 6,200 | 2,800 |
| 30 | 4,450 | 2,100 |
| 35 | 3,200 | 1,500 |
| 40 | 2,300 | 1,000 |

FRONT & REAR OUTRIGGERS
FULLY SPREAD
260° & 360° SWING

| Radius in Feet | With Outriggers | |
|----------------|---------------------|---------------------|
| | Front | 360°* |
| 10 | 15,000 ¹ | 15,000 ¹ |
| 12 | 14,000 ² | 14,000 ² |
| 15 | 12,000 ³ | 12,000 ³ |
| 20 | 9,000 | 7,000 |
| 25 | 6,200 | 4,800 |
| 30 | 4,450 | 3,500 |
| 35 | 3,200 | 2,600 |
| 40 | 2,300 | 1,900 |

- (1) For 15,000 lbs. lifting capacity - maximum boom length 30 ft.
 (2) For 14,000 lbs. lifting capacity - maximum boom length 34 ft.
 (3) For 12,000 lbs. lifting capacity - maximum boom length 38 ft.

NOTES TO LIFTING CAPACITIES Applies to All Above Load Charts

*Outriggers required in spread position.
 **Capacities also applicable when outriggers are used vertically.
 Capacities appearing above bold line are based on machinery strength and tipping should not be relied upon as a capacity limitation.



- Rated lifting capacities, with or without outriggers, are the maximum loads covered by the manufacturer's warranty with the machine standing on a firm, level and uniform surface. Capacities do not exceed 85% of tipping.
- For certain conditions, capacities are controlled by machinery strength. Machine tipping must not be relied upon as the capacity limitation.
- The weights of all load-handling devices are considered part of the load lifted and suitable allowances for them should be made.

EXCLUSIVE DUAL POSITION OUTRIGGERS permit the oblique spread position for maximum stability or the vertical position for use where space is limited.

THE WORLD'S MOST COMPLETE LINE OF HYDRAULIC INDUSTRIAL CRANES

**Capacities
from
2 through
35 tons
(1.8-31.8 metric tons)**



MODEL 24
4/6-Ton Capacity
3.6/5.4 metric tons



MODEL 1012
15/17½-Ton Capacity
13.6/15.9 metric tons



MODEL 68
10/12-Ton Capacity
9/10.9 metric tons



STEVEDORE
2-Ton Capacity
1.8 metric tons



MODEL 2535
25/35-Ton Capacity
22.7/31.7 metric tons



**INDUSTRIAL
CRANES**

Your Grove Distributor

GROVE MANUFACTURING COMPANY
A DIVISION OF WALTER KIDDE & COMPANY, INC.
P. O. BOX 160/GREENCASTLE, PENNSYLVANIA 17225