

# GROVE<sup>®</sup> COLES

# AT 745

All-terrain hydraulic crane

- Maximum on-board tip height 43 metres (141 ft)
- 4 x 4 wheel drive with four wheel steer
- Maximum speed 70 kph (43.5 mph)
- Telescopic Swingaway 9.30 – 12.80 – 16.40 metres (30 ft 6 in – 42 ft – 53 ft 9 in). Offsettable at 0°, 15° or 30°



# Carrier specifications

<b>Frame</b>	High strength steel, all-welded design with integral outrigger housing, and incorporating towing/tie down bracket.	<b>Suspension</b>	Integral hydrogas type all-round. Hydraulic lockout for 'on rubber' crane operation.
<b>Outrigger system</b>	Single stage, hydraulic telescopic beam and jack outriggers with integral holding valves. Quick-release type outrigger floats, 400 mm (16 in) diameter.	<b>Brakes</b>	Front: disc Rear: drums Dual-line air system operating on all wheels. Spring-applied air-released park brake acting on rear axle. Engine exhaust brake.
<b>Outrigger controls</b>	Situated in the superstructure cab. Push-button electric controls requiring two-handed operation for safety. Crane level indicator adjacent to controls.	<b>Tyres</b>	16.00 x 25 on-off highway radials all round. Tyre inflation kit. Optional *20.50 x 25 on-off highway radials all-round.
<b>Engine</b>	Deutz BF6L513R, six-cylinder, turbocharged air-cooled diesel. 9.6 litres, 177 kw (240 bhp) at 2300 rpm; maximum torque 905 Nm (668 lb ft) at 1500 rpm.	<b>Lights</b>	Full lighting including head, tail, braking, reversing, fog, directional and hazard warning lights.
<b>Fuel tank capacity</b>	209 litres (55 US gallons).	<b>Cab</b>	Full vision, all-steel fabricated with acoustic lining and tinted safety glass throughout, left-hand drive, rearview mirrors. Fully adjustable seat, complete driving controls and comprehensive instrumentation, high output heater and demister fan.
<b>Electrical system</b>	24 v (including starting).	<b>Maximum speed</b>	70 kph (43.5 mph).
<b>Drive</b>	4 x 2/4 x 4.	<b>Gross vehicle weight and axle loads</b>	Machine to basic specification. Axle 1: 12,000 kg (26,455 lb) Axle 2: 12,000 kg (26,455 lb) GVW: 24,000 kg (52,910 lb)
<b>Steering</b>	Fully independent power steering providing independent front or rear wheel steering and four-wheel co-ordinated or crab steering. Front: Mechanical power assisted steering controlled by steering wheel. Rear: Independent hydraulically powered steering. Lockout for rear axle when centralised. Automatic steering reversal system to ensure correct control regardless of superstructure position.	<b>Optional *equipment</b>	<b>Superstructure</b> * Load moment indicator * Anti-two block system * Hoist-drum rotation indicator * Auxiliary hoist * Spotlight * Rotating beacon * Hookblocks  <b>Carrier</b> * Spare wheel and stowage assembly * Rotating beacon
<b>Transmission</b>	Powershift gearbox with six forward, three reverse speeds. Engine mounted torque converter with automatic lock-up for highway travel. Four-wheel drive automatically engaged in first and second speed forward, and first speed reverse.		
<b>Axles</b>	Front and rear: Drive-steer with differential and planetary hub reduction.		

\*Indicates optional item.

# Superstructure specifications

<b>Boom</b>	9.80 to 24.40 m (32 ft to 80 ft), three-section full-power Trapezoidal boom. Positively synchronised extension/retraction with single lever control. Telescopic sections slide on adjustable and replaceable Nylatron pads. Maximum tip height 27 m (88 ft).
<b>Telescopic offsettable Swingaway extension</b>	9.30 to 12.80 or 16.40 m (30 ft 6 in to 42 ft or 53 ft 9 in) Swingaway extension, with a rectangular roller-mounted section extended from within the 9.30 m (30 ft) lattice extension. Offsettable at 0°, 15° or 30°. Stows alongside boom when not in use. Maximum tip height 43 m (141 ft).
<b>Optional *non-telescopic offsettable Swingaway extension</b>	9.30 m (30 ft 6 in) lattice Swingaway extension, offsettable at 0°, 15° or 30°. Stows alongside boom when not in use. Maximum tip height 36 m (118 ft).
<b>Boom nose</b>	Six sheaves, mounted on heavy duty tapered roller bearings with removable pin-type rope guards. Optional *auxiliary boom nose for single-line lifting.
<b>Boom elevation</b>	One double-acting hydraulic cylinder with integral holding valves provides elevation from -3° to +78°.
<b>Cab</b>	Full vision, all-steel fabricated with acoustic lining and tinted safety glass throughout. Dash panel incorporates gauges for all engine functions. Deluxe seat with arm-rest mounted hydraulic joystick controls. Complete driving controls, hinged skylight, electric windscreen and skylight wipers, horn and diesel cab heater.
<b>Swing</b>	Ball-bearing swing circle with 360° continuous rotation. Grove planetary glideswing with foot applied multi-disc brake. Spring-applied hydraulically released park brake. Plunger-type, two position house lock. Maximum speed 2.2 rpm.
<b>Counterweight</b>	Fixed position, 1000 kg (2200 lb) permanently mounted. Additional *4000 kg (8818 lb) pin mounted, two piece counterweight.

## HYDRAULIC SYSTEM

<b>Pumps</b>	Three main gear pumps, combined capacity 406 litres/minute (107 US gallons/minute). Maximum pressure 246 kg/cm <sup>2</sup> (3500 PSI).
<b>Valves</b>	Precision, four-way, double-acting pilot control operated valves, with three individual valve banks permit simultaneous control of multiple crane functions.
<b>Filter</b>	Return line type filter, with by-pass protection and indicator. 10 micron rated cartridge.
<b>Reservoir</b>	400 litres (106 US gallons) capacity, with internal baffles, particle magnet, clean out access and exterior oil level gauge.
<b>Oil cooler</b>	Thermostatically controlled, electric motor driven fan.
<b>Pressure check panel</b>	System pressure test panel with quick-release couplings.

## HOIST SPECIFICATIONS

	<b>Main hoist Grove HO15C-20</b>	<b>*Auxiliary hoist Grove HO15C-16</b>
<b>Maximum single line speed</b>		
Bottom layer	96 m/min (315 fpm)	56 m/min (184 fpm)
Intermediate layer	106 m/min (348 fpm)	60 m/min (197 fpm)
Top layer	115 m/min (377 fpm)	64 m/min (210 fpm)
<b>Maximum single line pull</b>		
Bottom layer	3662 kg (8073 lb)	3662 kg (8073 lb)
Intermediate layer	3497 kg (7709 lb)	3497 kg (7709 lb)
Top layer	3333 kg (7348 lb)	3333 kg (7348 lb)
<b>Maximum permissible line pull</b>	3333 kg (7348 lb)	3333 kg (7348 lb)
<b>Maximum rope stowage</b>	185 m x 14 mm (607 ft x 9/16 in)	146 m x 14 mm (479 ft x 9/16 in)
<b>Standard rope supplied</b>	185 m x 14 mm (607 ft x 9/16 in)	137 m x 14 mm (450 ft x 9/16 in)

\*Indicates optional item.

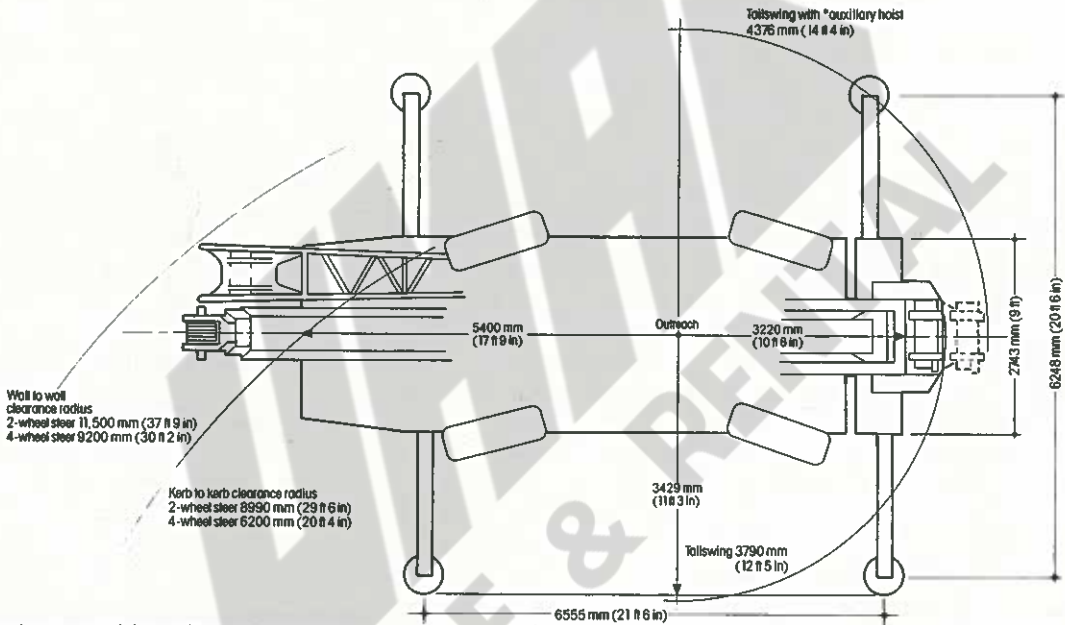
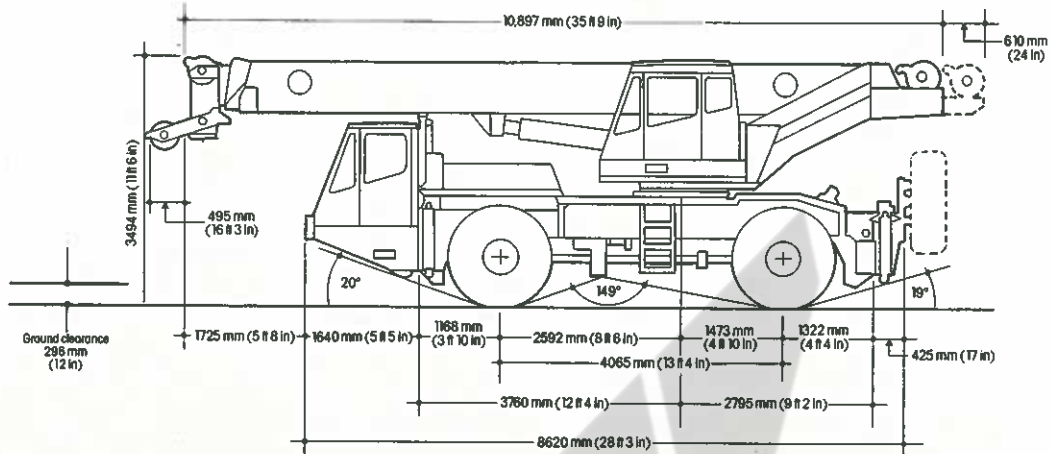

Dimensions refer to machine with standard tyres



**GROVE COLES LIMITED**  
 International Sales and Marketing  
 Telford Road, Bicester  
 Oxon. OX6 0TZ.

Telephone: Bicester (0869) 246800  
 Telex: 837447 Cranes G  
 Fax: Bicester (0869) 246965

Constant improvement and engineering progress make it necessary that the company reserves the right to make specification, equipment and price changes without notice. Illustrations shown may include optional equipment and accessories and may not include all standard equipment. Optional equipment is designated by (\*) in specifications folder.