



TR-350XL

35 Ton Capacity (31.7 Metric Tons)

HYDRAULIC ROUGH TERRAIN CRANE

DIMENSIONS

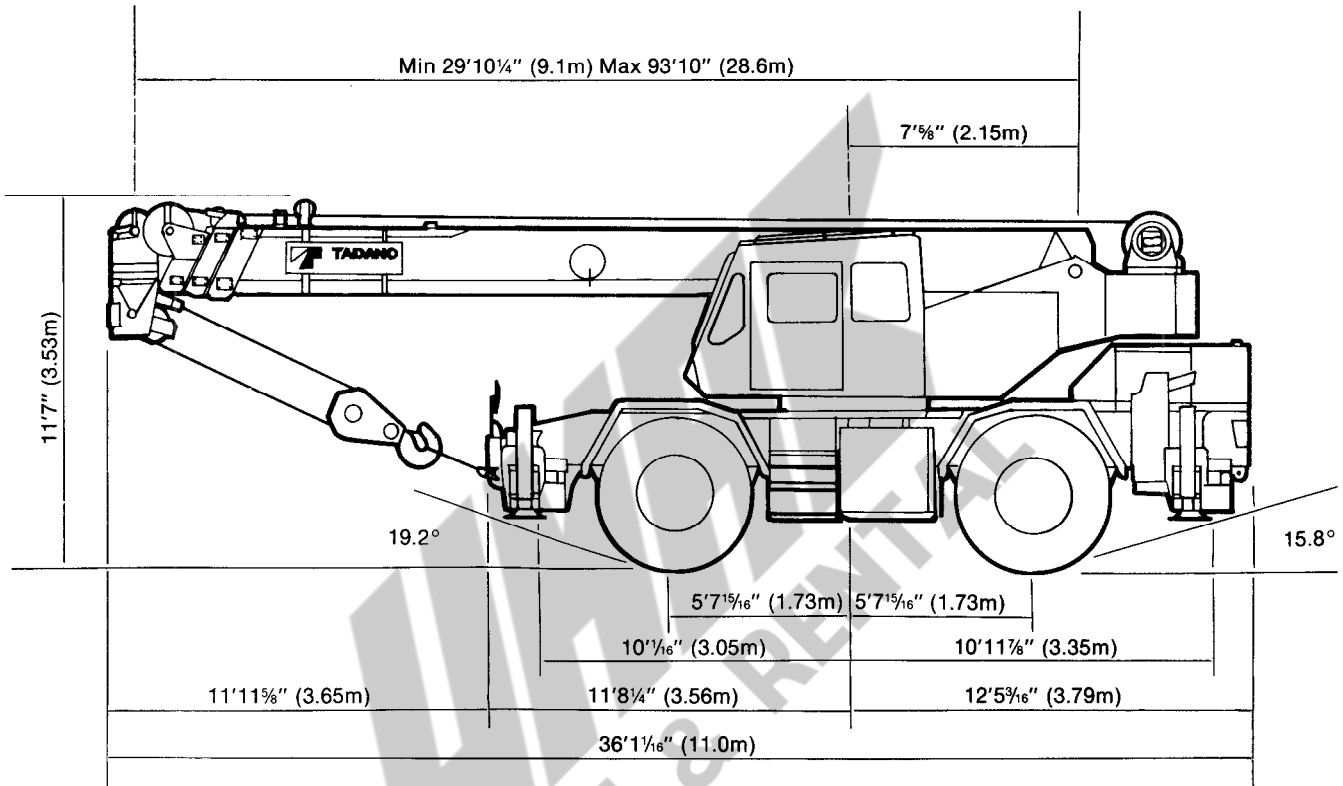

GENERAL DIMENSIONS (20.5 X 25 Tires)

	Feet	Meters
Tail swing counterweight	10'10"	3.3
Turning Radius:		
4 wheel steer	20' 10"	6.35
2 wheel steer	35' 3 1/4"	10.8

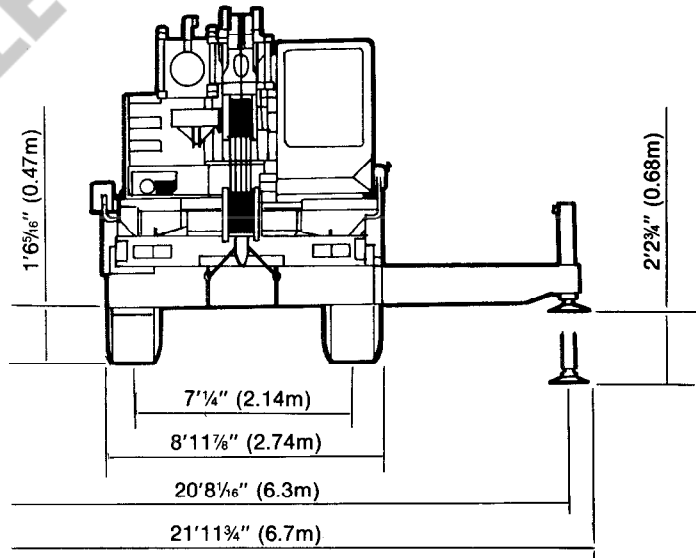

CRANE SPECIFICATIONS

BOOM

Four section full power partially synchronized telescoping boom, 29.9'~93.8' (9.1~28.6m), of box construction with five sheaves, 12 5/8" (0.32m) root diameter, at boom head. The synchronization system consist of two telescope cylinders, an extension cable and retraction cable. Hydraulic cylinders fitted with holding valves. Two easily removable wire rope guards, rope dead end provided on right side of boom head. Boom telescope sections are supported by wear pads both vertically and horizontally.

BOOM ELEVATION - By a double acting hydraulic cylinder with holding valve. Elevation 0°~80°, combination controls for hand or foot operation. Boom angle indicator.

JIB - Box type top section telescopes from lattice type base section which stores alongside base boom section. 5°, 25° or 45° offset (tilt type). Single sheave, 13 7/8" (0.352m) root diameter, at jib head. Jib length is 23.6' (7.2m) or 42' (12.8m).

AUXILIARY LIFTING SHEAVE (SINGLE TOP) - Single sheave, 12 5/8" (0.32 m) root diameter. Mounted to main boom head for single line work. (Stowable.)

ANTI-TWO BLOCK - Pendant type over-winding cut out device with audio-visual (FAILURE lamp/BUZZER) warning system.

SWING

Hydraulic axial piston motor driven through planetary swing speed reducer. Continuous 360° full circle swing on ball bearing turntable at 3.4 rpm. Equipped with manually locked/released swing brake. A swing lock (pin-in-hole lock) for pick and carry and travel modes, manually engaged in cab.

HOIST

MAIN HOIST - Variable speed type with grooved drum driven by hydraulic axial piston motor through winch speed reducer. Power load lowering and raising. Equipped with automatic brake (Neutral brake) and counterbalance valve. Controlled independently of auxiliary hoist.

DRUM - Grooved 12 5/8" (0.320 m) root diameter x 19 1/16" (0.4845 m) wide. Wire rope: 574 ft. of 5/8" diameter rope (175m of 16mm). Drum Capacity: 734 ft. (223.6m) 6 layers. Maximum line pull (permissible): 10, 078 lbs. (4 571 kg)*. Maximum line speed: 394 FPM (120 m/min).

AUXILIARY HOIST - Variable speed type with grooved drum driven by hydraulic axial piston motor through winch speed reducer. Power load lowering and raising. Equipped with automatic brake (neutral brake) and counterbalance valve. Controlled independently from main hoist.

DRUM - Grooved 12 5/8" (0.320 m) root diameter x 10 3/8" (0.2635 m) wide. Wire rope: 295 ft. of 5/8" diameter rope (90m of 16mm). Drum capacity: 399 ft. (121.6m) 6 layers. Maximum line pull (permissible): 10, 078 lbs. (4 571 kg)*. Maximum line speed: 394 FPM (120m/min).

*Maximum permissible line pull may be affected by wire rope strength.

Wire Rope - Filler wire, extra improved plow steel, pre-formed, independent wire rope core, right regular lay.
5/8" (16mm) 6 x 37 class

HOOK BLOCKS

1. 35 ton (31.7 metric ton) - 5 sheaves with swivel hook and safety latch, for 5/8" (16mm) wire rope.
2. 22 ton (20 metric ton)-3 sheaves with swivel hook and safety latch, for 5/8" (16mm) wire rope.
3. 4.4 ton (4.0 metric ton) - Weighted hook with swivel and safety latch, for 5/8" (16mm) wire rope.

HYDRAULIC SYSTEM

PUMPS - Two variable piston pumps for telescope, elevation, and hoist. Tandem gear pump for swing, outriggers, steering and optional equipment. Powered by carrier engine. Pump disconnect for crane is engaged/disengaged by rotary switch from operator's cab.

CONTROL VALVES - Multiple valves actuated by hand levers with integral pressure relief valves.

RESERVOIR - 120 gallon (456 lit.) capacity. External sight level gauge.

FILTRATION - 26 micron return filter, full flow with bypass protection, located inside of hydraulic reservoir. Accessible for easy replacement.

CAB AND CONTROLS

Both crane and drive operations can be performed from one cab mounted on rotating superstructure.

Left side, 1 man type, steel construction with sliding door access and safety glass windows opening at side, rear and roof. Wind-shield glass window is shatter-resistant. Tilt-telescoping steering wheel. Adjustable control levers for swing, boom telescoping, boom hoist, auxiliary hoist and main hoist (with swing free-lock selector switch). Control levers for swing and boom hoist can change neutral positions and tilt for easy access to cab. Engine throttle knob. Foot operated controls: boom hoist, service brake and engine throttle.

Dash-mounted engine start/stop, monitor lamps, cigarette lighter, parking brake switch, steering mode select switch, rear steering lock switch.

Instruments - Torque converter oil temperature, engine water temperature, air pressure, fuel, hydraulic oil pressure, speedometer, tachometer and hour meter

Tadano electronic LOAD MOMENT INDICATOR system (AML-M) including:

- Control lever lockout function
- Working radius and/or boom angle preset function (warning only)
- Warning buzzer
- Boom angle/boom length/jib offset angle/working radius rated loads/actual loads read out
- Ratio of actual load moment to rated load moment indication
- Working condition register switch
- External warning lamp

Operator's cab console includes transmission gear selector, pump engaged/disengaged switch, suspension spring lock switch, outrigger controls, sight level bubble, drive selector switch, swing free-lock selector switch, working light switch and ashtray. Swing lock knob, swing brake and 4 way adjustable seat with high back (with seat belt).

CARRIER SPECIFICATIONS

TYPE - Rear engine, left hand steering, driving axle 2-way selected type by manual switch, 4 x 2 front drive, 4 x 4 front and rear drive.

FRAME - High tensile steel, all welded box construction.

AUTOMATIC TRANSMISSION - Electronically controlled full automatic transmission. Torque converter driving full powershift with driving axle selector. 6 forward and 2 reverse speeds, constant mesh.

3 speeds - high range - 2 wheel drive; 4 wheel drive
3 speeds - low range - 4 wheel drive

TRAVEL SPEED - 31.2 mph maximum.

AXLE - Front: Full floating type, steering and driving axle with planetary reduction. Rear: Full floating type, steering and driving axle with planetary reduction. Non-spin differential.

STEERING - Hydraulic power steering controlled by steering wheel. Three steering modes available: 2 wheel front, 4 wheel coordinated and 4 wheel crab.

SUSPENSION - Front: Semi-elliptic leaf springs with hydraulic lockout device. Rear: Semi-elliptic leaf springs with hydraulic lockout device

BRAKE SYSTEMS - Service: Air over hydraulic disc brakes on all 4 wheels. Parking/Emergency: Spring applied—air released brake acting on input shaft of front axle.

TIRES Standard 20.5 x 25 - 24 PR (OR),

OUTRIGGERS - Four hydraulic, beam and jack outriggers. Vertical jack cylinders equipped with integral holding valve. Each outrigger beam and jack is controlled independently from cab. Beams extend to 20' 8 1/16" (6.3m) centerline-to-centerline and retract to within 8' 6 3/8" (2.6m) overall width with floats. Outrigger jack floats are attached thus eliminating the need of manually attaching and detaching them. Controls and sight bubble located in upper structure cab.

ENGINE

Model	Mitsubishi 6D16T
Type	Direct Injection Diesel
No. of cylinders	6
Combustion	4 cycle, turbo charged
Bore x Stroke, in. (mm)	4.646 x 4.528 (118 x 115)
Displacement, cu. in (liters)	460 (7.545)
Air inlet heater	24 volt preheat
Air cleaner	Dry type, replacement element (dual)
Oil filter	Full flow with replacement element
Fuel Filter	Full flow with replacement element
Fuel tank, gal. (liters)	79.3 (300), right side of carrier
Cooling	Liquid pressurized, recirculating by-pass

Radiator	Fin and tube core, thermostat controlled
Fan, in. (mm)	Suction type, 6-blade, 23.6 (600) dia.
Starting	24 volt
Charging	24 volt system, negative ground
Battery	2 - 140 amp. hour
Compressor, air, CFM (l/min)	21.3 CFM (602) at 2,000 rpm
Horsepower,(kW)	Net 215 (158) at 2800 rpm
Torque, Max. ft-lb (kgm)	470 (65) at 1600 rpm
Capacity, gal. (liters)	
Cooling water	3.4 (13)
Lubrication	3.7~4.2(14~16)

STANDARD EQUIPMENT

- Four section full power partially synchronized boom 29.9' - 93.8' (9.1m - 28.6m)
- Two stage stowable telescoping jib 23.6' (7.2m) or 42' (12.8m) with 5°, 25°, 45° pinned offset (tilt type)
- Auxiliary lifting sheave (single top) stowable
- Boom hoist foot control
- Boom angle indicator
- Variable speed main hoist driven by axial piston motor
- Variable speed auxiliary hoist with cable follower
- Tadano twin swing system
- 4 x 4 x 4 drive
- Hydraulic lockout suspension system
- Independently controlled outriggers
- Self-storing outrigger pads
- Electronic controlled automatic transmission driven by torque converter
- Complete highway light package
- Anti two block device (Overwind cutout)
- Electronic crane monitoring system
- Tadano electronic load moment indicator system (AML-ML) including:
 - Control lever lockout function
 - Working radius and/or boom angle preset function (warning only)
 - Warning buzzer
 - Boom angle/boom length/jib offset angle/working radius/ rated loads/actual loads read out
 - Ratio of actual load moment to rated load moment indication
 - Working condition register switch
 - External warning lamp
- Front windshield wiper and washer
- Roof windshield wiper
- Roof windshield lock warning

- Rear view mirrors (right and left side)
- 4 way adjustable seat with high back
- Tilt-telescoping steering wheel
- Neutral position adjustable control lever (swing and boom hoist)
- Seat belt
- Cab floor mat
- Electric fan in cab
- Back up alarm
- Low oil pressure/high water temperature warning device (visual)
- Fenders
- Towing hooks - front and rear
- Lifting eyes
- Tool storage compartment- External warning lamp
- Full instrumentation package
- Pump disconnect in operator's cab
- Non-spin rear differential
- Water separator with filter
- Flood lights
- Outrigger hose protection
- 24 volt electric system
- 24 volt start
- Tire inflation kit (with tire pressure gauge)
- 35 ton (31.7 metric ton) 5 sheave hook block
- 4.4ton (4 metric ton) hook ball and swivel

OPTIONAL EQUIPMENT

- 22 ton (20 metric ton) 2 sheave hook block
- Propane heater
- Fire extinguisher
- Tool kit
- Drum rotation indicator (thumper type) main and/or aux hoist

HOISTING SPECIFICATIONS

LINE SPEEDS AND PULLS

Layer	Speed	Main or auxiliary hoist - 12 5/8" (0.32 m) drum					
		Line Speeds ²		Line pulls			
		F.P.M	m/min	Available ¹		Permissible ⁴	
				Lbs.	kgf	Lbs.	kgf
1st	Low	133	41	11,086	5028	10,078	4571
	High	266	81				
2nd	Low	146	45	10,642	4827	9675	4388
	High	292	89				
3rd	Low	159	49	10,270	4658	9336	4235
	High	318	97				
4th	Low	171	52	9953	4515	9048	4104
	High	341	104				
5th	Low	184	56	9680	4391	8800	3992
	High	367	112				
6th ³	Low	197	60	9442	4283	8584	3893
	High	394	120				

DRUM WIRE ROPE CAPACITIES

Wire Rope Layer	Main Drum Grooved Lagging 5/8" (16 mm) wire rope				Aux. Drum Grooved Lagging 5/8" (16 mm) wire rope			
	Rope per layer		Total wire rope		Rope per layer		Total wire rope	
	Feet	Meters	Feet	Meters	Feet	Meters	Feet	Meters
1	99	30.1	99	30.1	54	16.4	54	16.4
2	108	32.9	207	63.0	59	17.9	113	34.3
3	117	35.8	324	98.8	64	19.5	117	53.8
4	127	38.7	451	137.5	69	21.0	245	74.8
5	136	41.6	588	179.1	74	22.6	320	97.4
6	146	44.5	734	223.6	79	24.2	399	121.6

DRUM DIMENSIONS

	MAIN		AUXILIARY	
	Inch	mm	Inch	mm
Root Diameter	12 5/8	320	12 5/8	320
Length	19 1/16	484.5	10 3/8	263.5
Flange Diameter	20 7/8	530	20 7/8	530

¹Developed by machinery with first layer of wire rope, but not based on rope strength or other limitation in machinery or equipment.

²Line speeds based only on hook block, not loaded.

³Sixth layer of wire rope is not recommended for hoisting operations.

⁴Permissible line pull may be affected by wire rope strength.

TR-350XL

OPERATING RADIUS / LIFTING HEIGHT CHART

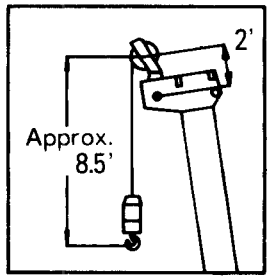
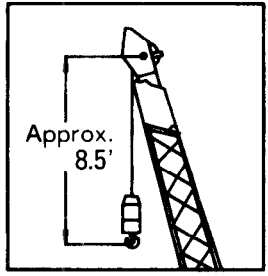
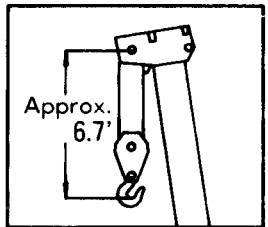
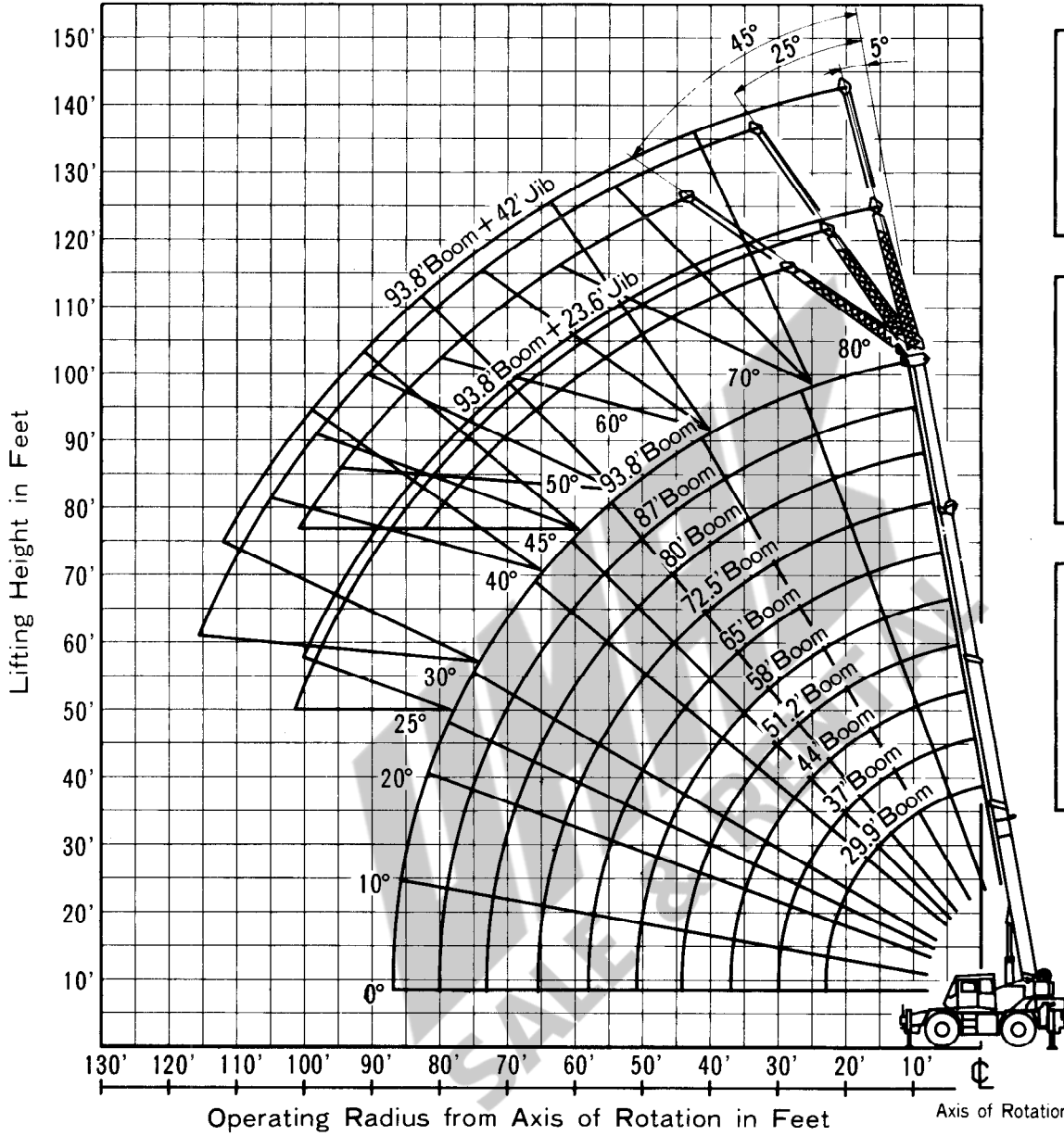

NOTE: Boom and jib geometry shown are for unloaded condition and machine standing level on firm supporting surface. Boom deflection and subsequent radius and boom angle change must be accounted for when applying load to hook.

TR-350XL TOTAL RATED LOAD CHART (IN POUNDS)

ON OUTRIGGERS FULLY EXTENDED 360° ROTATION											
Load Radius in Feet	Boom Length in Feet										
	29.9 (9.1m)	37 (11.3m)	44 (13.4m)	51.2 (15.6m)	58 (17.7m)	65 (19.8m)	72.5 (22.1m)	80 (24.4m)	87 (26.5m)	93.8 (28.6m)	
10	70,000 (58°)	49,900 (65°)	49,900 (69°)	43,200 (73°)	37,600 (75°)	36,600 (77°)	28,700 (78°)				
12	53,700 (53°)	49,900 (61°)	49,900 (66°)	43,200 (70°)	37,600 (73°)	35,000 (75°)	28,700 (77°)	26,500 (78°)			
15	46,100 (45°)	44,000 (56°)	42,700 (62°)	39,600 (67°)	33,400 (70°)	30,200 (73°)	28,700 (75°)	26,500 (77°)	22,400 (78°)	18,350 (79°)	
20	35,400 (28°)	34,600 (46°)	34,200 (54°)	31,300 (60°)	27,000 (65°)	25,100 (68°)	24,000 (70°)	21,500 (73°)	19,700 (74°)	18,350 (76°)	
25		26,600 (32°)	26,600 (45°)	25,100 (53°)	22,000 (58°)	21,000 (63°)	20,000 (66°)	17,800 (69°)	16,200 (71°)	15,700 (73°)	
30			20,000 (34°)	18,700 (46°)	18,000 (53°)	17,000 (57°)	16,600 (61°)	14,900 (65°)	13,700 (67°)	13,500 (69°)	
35			14,700 (19°)	14,800 (37°)	15,000 (46°)	14,300 (52°)	13,800 (57°)	12,600 (61°)	11,750 (64°)	11,600 (66°)	
40				11,600 (25°)	11,900 (38°)	11,600 (46°)	11,500 (52°)	10,700 (57°)	10,150 (60°)	10,100 (63°)	
45					9,400 (28°)	9,400 (39°)	9,350 (46°)	9,000 (52°)	8,900 (56°)	8,900 (59°)	
50						7,600 (11°)	7,900 (31°)	8,100 (40°)	8,100 (51°)	8,100 (55°)	
55							6,500 (19°)	6,700 (33°)	6,800 (41°)	6,800 (51°)	
60								5,650 (25°)	5,650 (35°)	5,650 (47°)	
65									4,800 (10°)	4,800 (28°)	
70										4,250 (17°)	
75											
80										3,600 (21°)	
85											

Boom Angles are in degrees. In the LOAD MOMENT INDICATOR (AML-M), the lifting capacity data based on the standard number of part line listed in the chart is stored.

Boom Angle in Degree	Boom Length in Feet							
	93.8(28.6m) Boom+23.6(7.2m) Jib	93.8(28.6m) Boom+42(12.8m) Jib	5° tilt	25° tilt	45° tilt	5° tilt	25° tilt	45° tilt
80°	6,600	4,400	3,300	4,400	2,200	1,500		
75°	6,600	4,400	3,300	4,400	2,200	1,500		
70°	6,500	4,400	3,300	3,700	2,200	1,500		
65°	5,200	3,900	3,300	3,150	2,000	1,500		
60°	4,300	3,400	3,050	2,700	1,900	1,450		
55°	3,650	3,000	2,750	2,300	1,750	1,400		
50°	3,100	2,700	2,500	2,000	1,600	1,350		
45°	2,700	2,400	2,350	1,750	1,450	1,300		
40°	2,000	1,850		1,550	1,350			
35°	1,550	1,400		1,200	1,100			
30°	1,200	1,100		950	900			
25°	950	950						

3,300lbs.(1,500kgs) shall be subtracted from the total rated load of the main boom when jib is attached to main boom head.

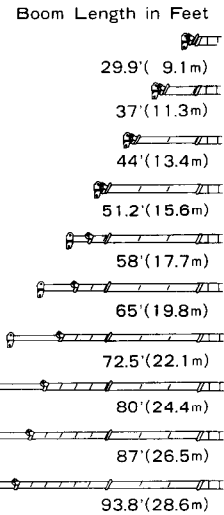

NOTE: Standard number of part lines for outrigger operation should be according to the following table.

Boom Length in Feet (meters)	29.9' (9.1)	37' to 51.2' (11.3 to 15.6)	58' to 72.5' (17.7 to 22.1)	80' to 93.8' (24.4 to 28.6)	Single top Jib
No. of part line	10	8	6	4	1

WARNING AND OPERATING INSTRUCTIONS FOR LIFTING CAPACITIES

GENERAL

- Total rated loads shown on the TOTAL RATED LOAD CHART apply only to the machine as originally manufactured and normally equipped by TADANO LTD. Modifications to the machine or use of optional equipment other than that specified can result in a reduction of capacity.
- Construction equipment can be dangerous if improperly operated or maintained. Operation and maintenance of this machine must be in compliance with the information in the operation, safety and maintenance manual supplied with machine. If this manual is missing, order replacement through the distributor.
- The operator and other personnel associated with this machine shall fully acquaint themselves with the latest applicable American National Standards Institute (ANSI) safety standards for cranes.

SET UP

- Total rated loads shown on the chart are the maximum allowable crane capacities and are based on the machine standing level on firm supporting surface under ideal job conditions. Depending on the nature of the supporting surface, it may be necessary to have structural supports under the outrigger floats or tires to spread the load to a larger bearing surface.
- For outrigger operation, outriggers shall be fully extended with tires free of supporting surface before operating crane.

OPERATION

- Total rated loads with outriggers fully extended do not exceed 85% of the tipping loads as determined by SAE Crane Stability Test Code J-765.
- Total rated loads above bold lines in the chart are based on crane strength and those below, on its stability. They are based on actual load radius increased by boom deflection.
- Total rated loads include the weight of main hook block (770 lbs for 35 tons capacity), auxiliary hook ball (220 lbs for 4.4 tons capacity), sling and auxiliary lifting devices and their weights shall be subtracted from the listed capacities to obtain the net load to be lifted.
- Total rated loads are based on freely suspended loads and make no allowance for such factors as the effect of wind, sudden stopping of loads, supporting surface conditions, inflation of tires, operating speeds, side loads, etc. Side pull on boom or jib is extremely dangerous.
- Total rated loads do not account for wind on lifted load or boom. Total rated loads and boom length shall be appropriately reduced, when wind velocity is above 20 mph (9m/sec).
- Total rated loads at load radius shall not be exceeded. Do not tip the crane to determine allowable loads.
- Do not operate at boom lengths beyond radii or boom angle, where no capacities are shown. Crane may overturn without any load on the hook.
- When boom length is between values listed, refer to the total rated loads of the next longer and next shorter booms for the same radius. The lesser of the two total rated loads shall be used.
- When making lifts at a load radius not shown, use the next longer radius to determine allowable capacity.

- Load per line should not exceed 8,800 lbs (4000 kg).
- Loaded boom angles are approximate. The boom angle before loading should be greater to account for deflection.
- The 29.9' (9.1 m) boom length capacities are based on boom fully retracted. If not fully retracted [less than 37' (11.3 m) boom length], use the total rated loads for the 37' (11.3 m) boom length.
- Extension or retraction of the boom with loads may be attempted within the limits of the TOTAL RATED LOAD CHART. The ability to telescope loads is limited by hydraulic pressure, boom angle, boom length, crane maintenance, etc.
- For lifting capacity of single top, reduce the total rated loads of relevant boom by 550 lbs (250 kg). Capacities of single top shall not exceed 6,610 lbs (3000 kgs) including main hook.
- When erecting and stowing jib, be sure to retain it by hand or by other means to prevent its free movement.
- 3300 lbs (1500 kgs) shall be subtracted from the total rated loads of the main boom, when jib is attached to main boom head. Jib weight is 1300 lbs (590 kg).
- Use Anti-Two Block (OVERWIND CUTOUT) disable switch when erecting and stowing the jib and stowing the hook block. While the switch is pushed, the hoist does not stop, even when overwind condition occurs.
- For boom lengths with 23.6' (7.2 m) Jib, total rated loads are determined by loaded boom angle only in the column headed "93.8' (28.6 m) Boom + 23.6' (7.2 m) Jib". For boom length with 42' (12.8m) jib, total rated loads are determined by loaded boom angle only in the column headed "93.8' (28.6m) boom + 42' (12.8m) jib". For angles not shown, use the next lower loaded boom angle to determine allowable capacity.
- When lifting a load by using jib (auxiliary hoist) and boom (main hoist) simultaneously, do the following:
 - Illuminate the jib indicator lamps and make the jib offset display screen indicate the same value as the actual offset by repeatedly pushing the boom state register switch.
 - Before starting operation, make sure that the weight of load is within the total rated load for jib.

DEFINITIONS

- Load Radius:** Horizontal distance from a projection of the axis of rotation to supporting surface before loading to the center of the vertical hoist line or tackle with load applied.
- Loaded Boom Angle:** The angle between the boom base section and the horizontal, after lifting the total rated load at the load radius.
- Working Area:** Area measured in a circular arc about the centerline of rotation.
- Freely Suspended Load:** Load hanging free with no direct external force applied except by the hoist line.
- Side Load:** Horizontal side force applied to the lifted load either on the ground or in the air.

TR-350XL TOTAL RATED LOAD CHART (IN POUNDS)

TIRE : 20.5-25-24PR

Load Radius in Feet	ON RUBBER											
	Stationary								Creep			
	Over Front				360° Rotation				Over Front			
	Boom Length in Feet				Boom Length in Feet				Boom Length in Feet			
	29.9' (9.1m)	51.2' (15.6m)	65' (19.8m)	80' (24.4m)	29.9' (9.1m)	51.2' (15.6m)	65' (19.8m)	80' (24.4m)	29.9' (9.1m)	51.2' (15.6m)	65' (19.8m)	80' (24.4m)
10	36,900	29,000			25,600	25,250			30,600	26,100		
12	32,800	29,000	22,000		18,700	18,320	19,600		26,350	26,100	22,000	
15	27,600	25,000	22,000	13,500	12,570	12,200	13,200	13,500	21,500	21,250	19,700	13,500
20	17,750	17,450	17,500	13,000	7,200	6,850	7,800	8,300	15,850	15,650	15,600	13,000
25		11,480	11,800	11,800		4,050	4,850	5,500		11,480	11,800	11,800
30		8,030	8,600	9,250		2,270	3,070	3,640		8,030	8,600	9,250
35		5,700	6,550	6,950				2,400		5,700	6,550	6,950
40		4,100	4,900	5,500						4,100	4,900	5,500
45			3,650	4,250						3,650	4,250	
50			2,720	3,280						2,720	3,280	
55			2,000	2,500						2,000	2,500	
60				1,900							1,900	
65				1,380							1,380	

NOTE: 36,900 lbs. capacity requires 6 parts of line.

All other capacities for on rubber operation shall be picked using 4 parts of line.

In the LOAD MOMENT INDICATOR (AML-M), the lifting capacity data based on the standard number of part line listed in the chart is stored.

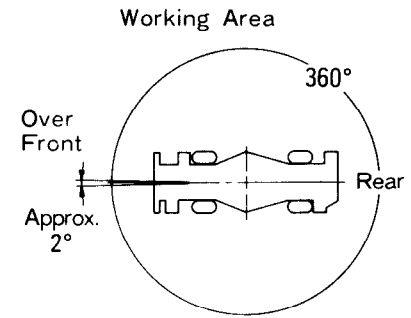

Boom Length in Feet

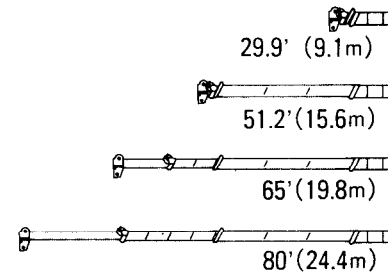

WARNING AND OPERATING INSTRUCTIONS FOR ON RUBBER CAPACITIES

- Total rated loads on rubber are in pounds and do not exceed 75% of tipping loads as determined by test in accordance with SAE J-765.
- Total rated loads shown in the chart are based on condition that crane is set on firm level surfaces with suspension lock applied. Those above bold lines are based on tire capacity and those below, on crane stability. They are based on actual load radius increased by tire deformation and boom deflection.
- Total rated loads are based on proper tire inflation, capacity and condition. Damaged tires are hazardous to safe operation of crane.
- Tires shall be inflated to correct air pressure.
- Over front operation shall be performed within two degrees in front of chassis.
- On rubber lifting with "jib" and "auxiliary lifting sheave" (single top) are not permitted.
- When making lift on rubber, set parking brake.
- For creep operation, boom must be centered over front of machine, swing lock engaged, and load restrained from swinging. Travel slowly and keep the lifted load as close to the ground as possible, and especially avoid any abrupt steering, accelerating or braking.
- Do not operate the crane while carrying the load.
- Creep is motion for crane not to travel more than 200 feet (60 m) in any 30 minute period and to travel at the speed of less than 1 mph (1.6 km/h).

TIRE AIR PRESSURE
20.50-25-24PR—93psi (6.55 kgf/cm²)

WARNING AND OPERATING INSTRUCTIONS FOR USING THE LOAD MOMENT INDICATOR (AML-M)

- When operating crane on outriggers:
 - Set P.T.O. switch to "ON".
 - Push the outrigger state register switch to illuminate the outrigger indicator lamps.
 - Push the boom state register switch repeatedly until the state of the indicator lamps and the offset display screen conforms to the actual state of the boom, the single top and the jib.
 - When erecting and stowing jib, push boom state register switch repeatedly until jib indicator lamps flicker (in jib erection/stowing mode).
 - When operating crane on rubber:
 - Lock suspension springs with boom over front and crane in traveling configuration.
 - Set P.T.O. switch to "ON".
 - Push the boom state register switch repeatedly to illuminate the boom indicator lamp.
 - Push the on rubber state register switch to illuminate the on rubber indicator lamps. By repeatedly pushing the on rubber register switch, stationary and creep operation are selected alternately. When creep operation is selected, the on rubber indicator lamps flicker.

However, pay attention to the following.

 - For stationary operation.
 - The front capacities are attainable only when the over front indicator lamp is on. When the boom is more than 2 degrees from centered over front of chassis, 360° capacities are in effect.
 - When a load is lifted in the front position and then swung to the side area, make sure the value of the LOAD MOMENT INDICATOR (AML-M) is below the 360° lifting capacity.
 - For creep operation.
 - The creep capacities are attainable only when boom is in the straight forward position of chassis and the over front indicator is on. If boom is not in the straight forward position of chassis, never lift load.
 - During crane operation, make sure that the displays on front panel are in accordance with actual operating conditions.
 - The displayed values of LOAD MOMENT INDICATOR (AML-M) are based on freely suspended loads and make no allowance for such factors as the effect of wind, sudden stopping of loads, supporting surface conditions, inflation of tire, operating speed, side loads, etc.
- For safe operation, it is recommended when extending and lowering boom or swinging, lifting loads shall be appropriately reduced.
- LOAD MOMENT INDICATOR (AML-M) is intended as an aid to the operator. Under no condition should it be relied upon to replace use of capacity charts and operating instructions. Sole reliance upon LOAD MOMENT INDICATOR (AML-M) aids in place of good operating practice can cause an accident. The operator must exercise caution to assure safety.

TR-350XL Axle Weight Distribution Chart

	Pounds			Kilograms		
	GVW	Front	Rear	GVW	Front	Rear
Basic standard machine includes: 29.9'—93.8' (9.1—28.6m) 4-section boom 23.6' - 42' (7.2-12.8m) 2-stage jib Main hoist with 574 ft (175m) of 5/8" (16mm) wire rope Auxiliary hoist with 295ft (90m) of 5/8" (16mm) wire rope 35 ton (31.8 metric ton) hookblock 4.4 ton (4 metric ton) hookblock 4170 lbs. (1890kg) counterweight Mitsubishi 6D16T engine; 20.5 X 25—24 PR tires	59,966	29,859	30,107	27,200	13,544	13,656
Remove: 35 ton (31.8 metric ton) hookblock 4.4 ton (4 metric ton) hookblock	-750 -220	-1,372 + 98	+622 -319	-340 -100	- 622 + 45	+282 -145

