



# TR-300XL-3

30 Ton Capacity (27.2 Metric Ton)

## HYDRAULIC ROUGH TERRAIN CRANE

### DIMENSIONS

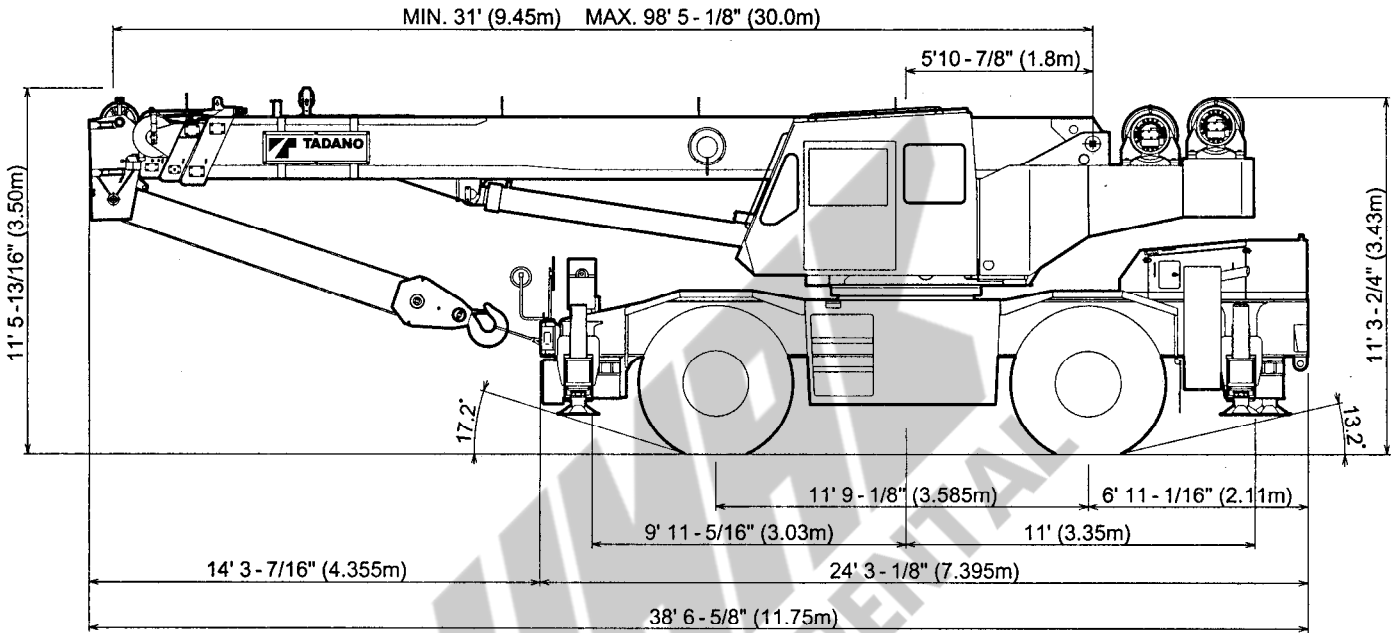

\* Drawing shows Installation of standard main winch and optional auxiliary winch.

### GENERAL DIMENSIONS (20.5×25Tires)

	Feet	Meters
Turning radius:		
4 wheel steer	21'	6.4
2 wheel steer	36'5"	11.1
Tail swing of counterweight	11'1-7/8"	3.4

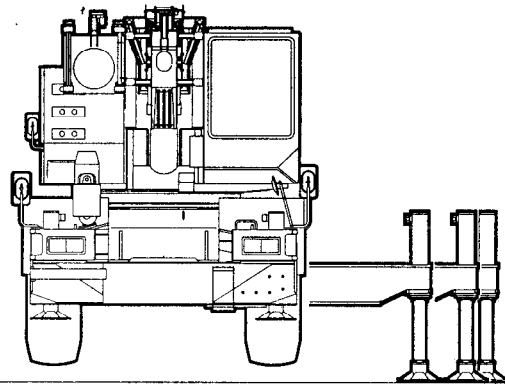

Specifications are subject to change without notice.

# CRANE SPECIFICATIONS

## BOOM

Four section full power synchronized telescoping boom, 31' ~ 98.4'(9.45m~ 30m), of box construction with four sheaves, 12-5/8" (0.32m) root diameter, at boom head. The synchronization system consists of a telescope cylinder, two extension cables and retraction cable. Hydraulic cylinder fitted with holding valve. Two easily removable wire rope guards, rope dead end provided on right side of boom head. Boom telescope sections are supported by wear pads both vertically and horizontally.

**BOOM ELEVATION** - By a double acting hydraulic cylinder with holding valve. Elevation 0°~80°, combination controls for hand or foot operation. Boom angle indicator.

**JIB** - Single stage lattice type, 5°, 25° or 45° offset (tilt type). Single sheave, 13-7/8" (0.352m) root diameter, at jib head. Stored alongside base boom section. Jib length is 24.6' (7.5m). Self stowing jib mounting pins.

## AUXILIARY LIFTING SHEAVE (SINGLE TOP)

Single sheave, 12-5/8" (0.32m) root diameter. Mounted to main boom head for single line work (stowable).

**ANTI-TWO BLOCK** - Pendant type over-winding cut out device with audio-visual (FAILURE lamp/BUZZER) warning system.

## SWING

Hydraulic axial piston motor driven through planetary swing speed reducer. Continuous 360° full circle swing on ball bearing turntable at 2.6rpm. Equipped with manually locked/released swing brake. A swing lock (360° positive swing lock) for pick and carry and travel modes, manually engaged in cab. Twin swing system : Free swing or lock swing controlled by selector switch on right hand console.

## HOIST

**MAIN HOIST** - Variable speed type with grooved drum driven by hydraulic axial piston motor through planetary winch speed reducer. Power load lowering and raising. Equipped with automatic brake(neutral brake)and counterbalance valve. Controlled independently of auxiliary hoist. Equipped with cable follower and drum rotation indicator.

**DRUM** - Grooved 12-5/8" (0.320m) root diameter × 19-1/16" (0.4845m) wide. Wire rope : 607' of 5/8" diameter rope (185m of 16mm). Drum capacity : 734' (223.6m) 6 layers. Maximum line pull (permissible) : 9,755lbs. (4,425 kgf) \*. Maximum line speed : 459FPM (140m/min).

**AUXILIARY HOIST (OPTIONAL)** - Variable speed type with grooved drum driven by hydraulic axial piston motor through planetary winch speed reducer. Power load lowering and raising. Equipped with automatic brake (neutral brake) and counterbalance valve. Controlled independently of main hoist. Equipped with cable follower and drum rotation indicator.

**DRUM** - Grooved 12-5/8" (0.320m) root diameter × 19-1/16" (0.4845m) wide. Wire rope : 279' of 5/8" diameter rope (85m of 16mm). Drum capacity : 734' (223.6m) 6 layers. Maximum line pull (permissible) : 9,755lbs. (4,425 kgf)\*. Maximum line speed : 459 FPM (140m/min).

\* Maximum permissible line pull may be affected by wire rope strength.

**WIRE ROPE** - Warrington seale wire, extra improved plow steel, pre-formed, independent wire rope core, right regular lay. 5/8" (16mm) 6 × 37 class

## HOOK BLOCKS

1. 30 ton (27.2 metric ton) - 4 sheaves with swivel hook and safety latch, for 5/8" (16mm) wire rope.
2. 4.4 ton (4.0 metric ton) - Weighted hook with swivel and safety latch, for 5/8" (16mm) wire rope.

## HYDRAULIC SYSTEM

**PUMPS** - Two variable piston pumps for crane functions. Tandem gear pump for steering, swing and optional equipment. Powered by carrier engine. Pump disconnect for crane is engaged/disengaged by rotary switch from operator's cab.

**CONTROL VALVES** - Multiple valves actuated by hand levers with integral pressure relief valves.

**RESERVOIR** - 139 gallon(527 lit.) capacity. External sight level gauge.

**FILTRATION** - 26 micron return filter, full flow with bypass protection, located inside of hydraulic reservoir. Accessible for easy replacement.

**OIL COOLER** - Air cooled fan type.

## CAB AND CONTROLS

Both crane and drive operations can be performed from one cab'mounted on rotating superstructure.

Left side, 1 man type, steel construction with sliding door access and tinted safety glass windows opening at side, rear and roof. Windshield glass window is shatter-resistant. Tilt-telescoping steering wheel. Adjustable control levers for swing, boom telescoping, boom hoist, auxiliary hoist and main hoist. Control levers for swing and auxiliary hoist can change neutral positions and tilt for easy access to cab. Engine throttle knob. Foot operated controls : boom hoist, boom telescoping, service brake and engine throttle.

Dash-mounted engine start/stop, monitor lamps, cigarette lighter, parking brake switch, steering mode select switch, pump engaged/disengaged switch, and swing brake switch.

Instruments - Torque converter oil temperature, engine water temperature, air pressure, fuel, speedometer, tachometer and hour meter. Torque converter oil pressure and hydraulic circuit pressure are monitored and displayed on the AML-L display panel.

Tadano electronic LOAD MOMENT INDICATOR system (AML-L) including :

- Control lever lockout function
- Working radius and/or boom angle and/or tip height preset function (warning only)
- Warning buzzer
- Boom angle/boom length/jib offset angle/working radius/rated loads/actual loads read out
- Ratio of actual load moment to rated load moment indication
- Working condition register switch
- External warning lamp
- Tadano AML-L monitors outrigger extended length and automatically programs the corresponding "Rated Lifting Capacities" for crane duty in confined areas.

## CARRIER SPECIFICATIONS

**TYPE** - Rear engine, left hand steering, driving axle 2-way selected type by manual switch, 4 × 2 front drive, 4 × 4 front and rear drive.

**FRAME** - High tensile steel, all welded mono-box construction.

**TRANSMISSION** - Electronically controlled full automatic transmission. Torque converter driving full powershift with driving axle selector. 6 forward and 2 reverse speeds, constant mesh.

- 3 speeds - High range - 2 wheel drive ; 4 wheel drive
- 3 speeds - Low range - 4 wheel drive

**MAX. TRAVEL SPEED** - 29.3mph (47km/h)

**AXLE** - Front : Full floating type, steering and driving axle with planetary reduction. Rear : Full floating type, steering and driving axle with planetary reduction. Non-spin differential.

**STEERING** - Hydraulic power steering controlled by steering wheel. Three steering modes available : 2 wheel front, 4 wheel coordinated and 4 wheel crab.

**SUSPENSION** - Front : Semi-elliptic leaf springs with hydraulic lockout device. Rear : Semi-elliptic leaf springs with hydraulic lockout device.

### ENGINE

Model	Mitsubishi 6D16-TLEA
Type	Direct injection Diesel
No. of cylinders	6
Combustion	4 cycle, turbo charged and after cooled
Bore × Stroke, in.(mm)	4.646 × 4.528 (118 × 115)
Displacement, cu. in (liters)	460 (7.545)
Air inlet heater	24 volt preheat
Air cleaner	Dry type,replaceable element
Oil filter	Full flow with replaceable element
Fuel filter	Full flow with replaceable element
Fuel tank, gal.(liters)	79.2 (300), right side of carrier
Cooling	Liquid pressurized, recirculating bypass

Operator's right hand console includes transmission gear selector, outrigger controls, sight level bubble, drive selector switch, free swing/lock swing selector switch, working light switch and ashtray. Swing lock lever and 4 way adjustable cloth seat with high back and seat belt. Roof window lock (closed) warning.

**NOTE** : Each crane motion speed is based on unladen conditions.

**BRAKE SYSTEMS** - Service : Air over hydraulic disc brakes on all 4 wheels. Parking/Emergency : Spring applied-air released brake acting on input shaft of front axle. Auxiliary : Electro-pneumatic operated exhaust brake.

**TIRES** - Standard 20.5-25-24PR (OR)

**OUTRIGGERS** - Four hydraulic, beam and jack outriggers. Vertical jack cylinders equipped with integral holding valve. Each outrigger beam and jack is controlled independently from cab. Beams extend to 20' 8-1/16" (6.3m) center-line and retract to within 8' 6-3/8" (2.6m) overall width with floats. Outrigger jack floats are attached thus eliminating the need of manually attaching and detaching them. Controls and sight bubble located in upper structure cab. Three outrigger extension lengths are provided with corresponding "RATED LIFTING CAPACITIES" for crane duty in confined areas.

- Mid. extension 16' 4-7/8" center to center
- Mid. extension 19' 4-1/4" center to center
- Max. extension 20' 8-1/16" center to center

Radiator	Fin and tube core, thermostat controlled
Fan, in.(mm)	Suction type, 6-blade, 23.6 (600) dia
Starting	24 volt
Charging	24 volt system, negative ground
Battery	2-120 amp. hour
Compressor, air, CFM( l /min)	10.6 CFM (301LPM) at 2,000rpm
Horsepower (kW)	Gross 247 (184) at 2,800rpm
Torque, Max. ft-lb (kgm)	521 (72) at 1,400rpm
Capacity, gal.(liters)	
Cooling water	3.4 (13)
Lubrication	3.7 ~ 4.2 (14 ~ 16)
Fuel	79.2 (300)

# STANDARD EQUIPMENT

- Four section full power synchronized boom 31'~ 98.4' (9.45m~30 m)
- Single stage stowable lattice jib 24.6' (7.5m) with 5°, 25°, or 45° pinned offset (tilt type) with self stowing pins
- Auxiliary lifting sheave (single top) stowable
- 30 ton (27.2 metric ton) 4 sheave hook block
- 4.4 ton (4.0 metric ton) hook ball and swivel
- Hook block tie down (front bumper)
- Weighted hook storage compartment
- Boom hoist foot control
- Boom telescoping foot control
- Boom angle indicator
- Variable speed main hoist with grooved drum, cable follower, drum rotation indicator, and 607' of 5/8" cable
- Tadano twin swing system
- 360° positive swing lock
- Mitsubishi 6D16-TLEA turbo charged after cooled engine (247HP) with exhaust brake
- 4 × 4 × 4 drive
- 20.5-25-24PR (OR) tires
- Disc brakes
- Hydraulic lockout suspension system
- Independently controlled outriggers
- Three outrigger extension positions
- Self-storing outrigger pads
- Outrigger extended position detector
- Electronic controlled automatic transmission driven by torque converter
- Engine over-run alarm
- Complete highway light package
- Anti-two block device (Overwind cutout)
- Electronic crane monitoring system
- Tadano electronic load moment indicator system (AML-L) including:
  - Control lever lockout function
  - Working radius and/or boom angle and/or tip height preset function (warning only)
  - Warning buzzer
  - Boom angle/boom length/jib offset angle/working radius/rated loads/actual loads read out
  - Ratio of actual load moment to rated load moment indication
  - Working condition register switch
  - External warning lamp

- Front windshield wiper and washer
- Roof window wiper and washer
- Roof window lock warning
- Rear view mirrors (right and left side)
- Tinted safety glass
- 4 way adjustable cloth seat with high back and seat belt
- Tilt-telescoping steering wheel
- Neutral position adjustable control levers (swing and auxiliary hoist)
- Cigarette lighter
- Cab floor mat
- Electric fan in cab
- Back-up alarm
- Low oil pressure/high water temperature warning device (visual)
- Rear steer centering light
- Fenders
- Air cleaner dust indicator
- Towing hooks - front and rear
- Lifting eyes
- Tool storage compartment
- Full instrumentation package
- Pump disconnect in operator's cab
- Air dryer
- Hydraulic oil cooler
- Non-spin rear differential
- Water separator with filter
- Flood lights and work lights
- Tire inflation kit (with tire pressure gauge)
- Outrigger hose protection
- 24 volt electric system

# OPTIONAL EQUIPMENT

- Variable speed auxiliary hoist with grooved drum, cable follower, drum rotation indicator, and 279' of 5/8" cable
- Fire extinguisher
- Air conditioning (hydraulic oil cab heater/defroster with dehumidification function and cab cooler/defroster)
- Propane cab heater (less tank)

# HOISTING SPECIFICATIONS

## LINE SPEEDS AND PULLS

Layer	Speed	Main or auxiliary hoist - 12-5/8" (0.32m) drum					
		Line speeds <sup>2</sup>		Line pulls			
				Available <sup>1</sup>		Permissible <sup>4</sup>	
		F.P.M	m/min	Lbs.	kgf	Lbs.	kgf
1st	High	311	95	13,170	5,974	10,525	4,774
2nd	High	340	104	12,024	5,454	9,610	4,359
3rd	High	370	113	11,063	5,018	8,841	4,010
4th	High	399	122	10,243	4,646	8,186	3,713
5th	High	429	131	9,537	4,326	7,621	3,457
6th <sup>3</sup>	High	459	140	8,922	4,047	7,130	3,234

<sup>1</sup> Developed by machinery with first layer of wire rope, but not based on rope strength or other limitation in machinery or equipment.

<sup>2</sup> Line speeds based only on hook block, not loaded.

<sup>3</sup> Sixth layer of wire rope is not recommended for hoisting operations.

<sup>4</sup> Permissible line pull may be affected by wire rope strength.

## DRUM WIRE ROPE CAPACITIES

Wire rope layer	Main and auxiliary drum grooved lagging			
	5/8" (16mm) wire rope			
	Rope per layer		Total wire rope	
	Feet	Meters	Feet	Meters
1	99	30.1	99	30.1
2	108	32.9	207	63.0
3	117	35.8	324	98.8
4	127	38.7	451	137.5
5	136	41.6	588	179.1
6	146	44.5	734	223.6

## DRUM DIMENSIONS

	Inch	mm
Root diameter	12-5/8"	320
Length	19-1/16"	484.5
Flange diameter	20-7/8"	530

# TR-300XL-3 WORKING RANGE CHART

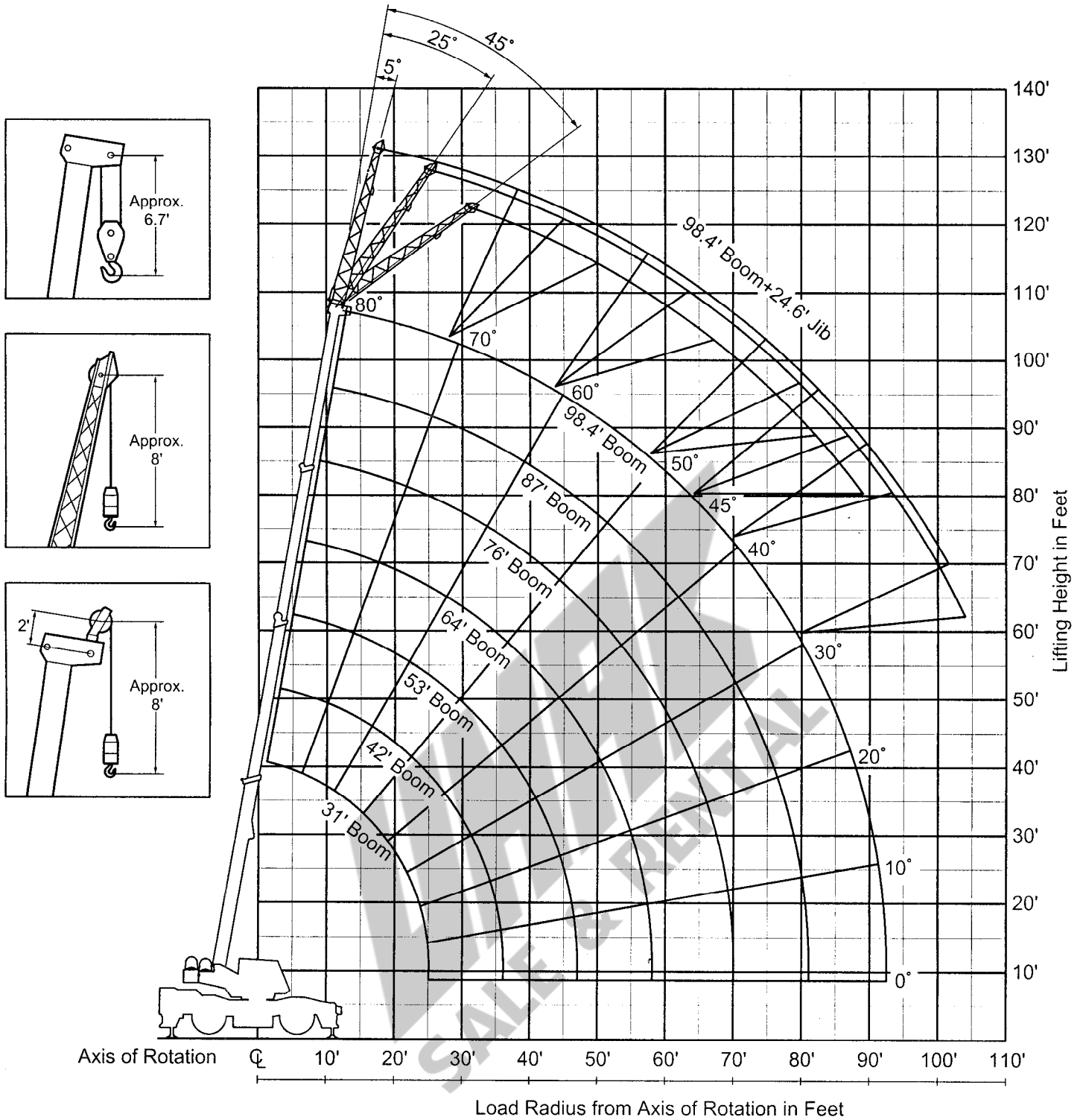

**NOTE :** Boom and jib geometry shown are for unloaded condition and machine standing level on firm supporting surface. Boom deflection and subsequent radius and boom angle change must be accounted for when applying load to hook.

# TR-300XL-3 RATED LIFTING CAPACITIES (IN POUNDS)

Boom Length In Feet

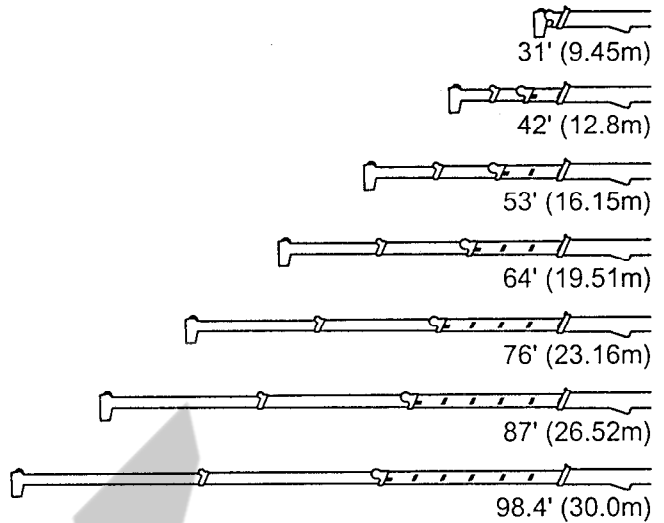

NOTE : Load radiuses for jib operation are given for reference with the boom fully extended to 98.4' (30m).

1,650lbs. (750kg) shall be subtracted from the rated lifting capacities of main boom, when jib is attached to main boom head.  
Jib weight is 840 lbs. (380kg).

Standard number of parts of line should be according to the following table.

Boom Length in Feet (meters)	31' (9.45)	31' to 64' (9.45 to 19.51)	64' to 98.4' (19.51 to 30.0)	Single top Jib
No. of parts of line	8	6	4	1

The lifting capacity data stored in the LOAD MOMENT INDICATOR (AML-L) is based on the standard number of parts of line listed in the chart.  
Maximum lifting capacity is restricted by the number of parts of line of LOAD MOMENT INDICATOR(AML-L).

Boom Angle in Degree	ON OUTRIGGERS FULLY EXTENDED 360° ROTATION								ON OUTRIGGERS MID. EXTENDED 19'4-1/4" (5.3m) SPREAD 360° ROTATION								ON OUTRIGGERS MID. EXTENDED 16'4-7/8" (5.0m) SPREAD 360° ROTATION							
	Boom Length in Feet				Boom Length in Feet				Boom Length in Feet				Boom Length in Feet				Boom Length in Feet							
	5' offset		25' offset		45' offset		5' offset		25' offset		45' offset		5' offset		25' offset		45' offset							
	R	W	R	W	R	W	R	W	R	W	R	W	R	W	R	W	R	W						
80°	20.6'	6,600	27.8'	4,400	33.6'	3,300	20.6'	6,600	27.8'	4,400	33.6'	3,300	20.6'	6,600	27.8'	4,400	33.6'	3,300						
75°	31.8'	6,600	38.6'	4,400	43.8'	3,300	31.8'	6,600	38.6'	4,400	43.8'	3,300	31.8'	6,600	38.6'	4,400	43.8'	3,300						
70°	42.6'	6,300	49.1'	4,400	53.4'	3,100	42.6'	6,300	49.1'	4,400	53.4'	3,100	42.6'	6,300	49.1'	4,400	53.4'	3,100						
65°	52.5'	5,200	58.7'	4,000	62.5'	2,950	52.5'	5,200	58.7'	4,000	62.5'	2,950	52.5'	5,200	58.6'	3,950	62.5'	2,950						
60°	61.9'	4,350	67.6'	3,550	70.9'	2,850	61.9'	4,350	67.6'	3,550	70.9'	2,850	61.6'	3,450	67.5'	3,050	70.9'	2,650						
55°	70.7'	3,750	76.0'	3,100	78.7'	2,750	70.6'	4,300	76.0'	3,100	78.7'	2,750	70.1'	2,200	75.5'	2,000	78.5'	1,950						
50°	79.0'	3,250	83.7'	2,750	85.9'	2,600	78.4'	2,400	83.5'	2,250	85.6'	2,000	78.1'	1,350	83.0'	1,200	85.3'	1,200						
45°	86.4'	2,200	90.4'	2,200	92.1'	2,200	86.1'	1,650	90.3'	1,550	91.7'	1,350												
40°	93.2'	1,750	96.8'	1,700			92.9'	1,050	96.5'	1,000														
35°	99.2'	1,350	102.0'	1,300																				
30°	105.0'	1,000	107.0'	950																				

R : Load radius in feet W : Rated lifting capacity in pounds

# TR-300XL-3 RATED LIFTING CAPACITIES (IN POUNDS)

ON OUTRIGGERS FULLY EXTENDED 360° ROTATION										ON OUTRIGGERS MID. EXTENDED 19'4-1/4" (5.9m) SPREAD 360° ROTATION										ON OUTRIGGERS MID. EXTENDED 16'4-7/8" (5.0m) SPREAD 360° ROTATION											
A	31'	42'	53'	64'	76'	87'	98.4'	31'	42'	53'	64'	76'	87'	98.4'	31'	42'	53'	64'	76'	87'	98.4'	A									
B	(9.45m)	(12.8m)	(16.15m)	(19.51m)	(23.16m)	(26.52m)	(30.0 m)	(9.45m)	(12.8m)	(16.15m)	(19.51m)	(23.16m)	(26.52m)	(30.0 m)	(9.45m)	(12.8m)	(16.15m)	(19.51m)	(23.16m)	(26.52m)	(30.0 m)	B									
10'	60,000	34,600	34,600	32,500				60,000	34,600	34,600	32,500				60,000	34,600	34,600	32,500				10'									
12'	56,500	34,600	34,600	32,500	30,000			56,500	34,600	34,600	32,500	30,000			56,500	34,600	34,600	32,500	30,000			12'									
15'	46,500	34,600	34,600	31,000	30,000	21,000		46,500	34,600	34,600	31,000	30,000	21,000		46,500	34,600	34,600	31,000	30,000	21,000		15'									
20'	36,000	34,600	34,600	28,500	27,000	21,000	19,100	36,000	34,600	34,600	28,500	27,000	21,000	19,100	28,000	28,000	28,000	26,800	27,000	21,000	19,100	20'									
25'		28,500	28,000	25,000	22,500	21,000	19,100		25,800	24,600	25,000	22,500	21,000	19,100		19,400	19,400	19,400	19,500	18,700	19,100	25'									
30'		21,700	21,700	22,000	19,000	17,500	16,800		18,000	18,200	18,200	18,200	17,500	16,800		13,800	14,300	14,100	14,500	14,350	14,550	30'									
35'		16,500	16,600	16,900	16,000	15,100	14,400		13,500	14,000	14,000	14,200	14,200	14,400		10,200	10,600	10,600	11,000	11,000	11,100	35'									
40'			13,200	13,600	13,800	13,000	12,600		10,900	10,900	11,200	11,250	11,250			8,100	8,200	8,550	8,600	8,600	8,700	40'									
45'			10,600	10,800	11,100	11,350	11,000		8,500	8,600	8,900	9,050	9,150			6,300	6,400	6,650	6,750	6,900	6,900	45'									
50'				8,800	9,000	9,300	9,300			6,900	7,150	7,300	7,550				4,900	5,150	5,350	5,450	5,450	50'									
55'					7,400	7,550	7,800			5,700	5,800	5,900	6,100					4,000	4,000	4,200	4,250	55'									
60'					6,150	6,250	6,450				4,750	4,750	4,850						3,200	3,250	3,350	60'									
65'					5,150	5,150	5,300				3,900	3,900	3,950						2,550	2,550	2,600	65'									
70'						4,300	4,350				3,200	3,200	3,200						2,000	2,000	2,000	70'									
75'						3,700	3,650				2,600	2,600	2,600						1,400	1,400	1,500	75'									
80'						3,000	3,000				2,100	2,100	2,100						1,000	1,000	1,050	80'									
85'							2,450														750	85'									
90'							2,200														1,300	90'									
C	0°										0°										0°										C

A : Boom length in feet    B : Load radius in feet    C : Minimum boom angle (deg.) for indicated length (no load)

# WARNING AND OPERATING INSTRUCTIONS FOR LIFTING CAPACITIES

## GENERAL

1. RATED LIFTING CAPACITIES apply only to the machine as originally manufactured and normally equipped by TADANO LTD. Modifications to the machine or use of optional equipment other than that specified can result in a reduction of capacity.
2. Construction equipment can be hazardous if improperly operated or maintained. Operation and maintenance of this machine must be in compliance with the information in the operation, safety and maintenance manual supplied with machine.
3. The operator and other personnel associated with this machine shall fully acquaint themselves with the latest American National Standards Institute (ANSI) safety standards for cranes.

## SET UP

1. Rated lifting capacities on the chart are the maximum allowable crane capacities and are based on the machine standing level on firm supporting surface under ideal job conditions. Depending on the nature of the supporting surface, it may be necessary to have structural supports under the outrigger floats or tires to spread the load to a larger bearing surface.
2. For outrigger operation, outriggers shall be properly extended with tires free of supporting surface before operating crane.

## OPERATION

1. Rated lifting capacities have been tested to and meet minimum requirements of SAE J1063-Cantilevered Boom Crane Structures-Method of Test.
2. Rated lifting capacities do not exceed 85% of the tipping load on outriggers fully extended as determined by SAE J765-Crane Stability Test Code. Rated lifting capacities for partially extended outriggers are determined from the formula, Rated Lifting Capacities = (Tipping Load - 0.1 × Tip Reaction) / 1.25.
3. Rated lifting capacities above bold lines in the chart are based on crane strength and those below, on its stability. They are based on actual load radius increased by boom deflection.
4. Rated lifting capacities include the weight of main hook block (600lbs. for 30 ton capacity), auxiliary hook block (220lbs. for 4.4 ton capacity), sling and auxiliary lifting devices and their weights shall be subtracted from the listed capacities to obtain the net load to be lifted.
5. Rated lifting capacities are based on freely suspended loads and make no allowance for such factors as the effect of wind, sudden stopping of loads, supporting surface conditions, inflation of tires, operating speeds, side loads, etc. Side pull on boom or jib is extremely dangerous.
6. Rated lifting capacities do not account for wind on lifted load or boom. Rated lifting capacities and boom length shall be appropriately reduced, when wind velocity is above 20mph (9m/sec.).
7. Rated lifting capacities at load radius shall not be exceeded. Do not tip the crane to determine allowable loads.
8. Do not operate at boom lengths, radii, or boom angle, where no capacities are shown. Crane may overturn without any load on the hook.
9. When boom length is between values listed, refer to the rated lifting capacities of the next longer and next shorter booms for the same radius. The lesser of the

- two rated lifting capacities shall be used.
10. When making lifts at a load radius not shown, use the next longer radius to determine allowable capacity.
11. Load per line should not exceed 7,500lbs.(3,400kg) for main winch and 6,600lbs. (3,000kg) for auxiliary winch.
12. Check the actual number of parts of line with LOAD MOMENT INDICATOR (AML-L) before operation. Maximum lifting capacity is restricted by the number of parts of line of LOAD MOMENT INDICATOR (AML-L). Limited capacity is as determined from the formula, Single line pull for main winch (7,500lbs.) × number of parts of line.
13. The boom angle before loading should be greater to account for deflection.
14. The 31' (9.45m) boom length capacities are based on boom fully retracted. If not fully retracted [less than 42' (12.8 m) boom length], use the rated lifting capacities for the 42' (12.8m) boom length.
15. Extension or retraction of the boom with loads may be attempted within the limits of the RATED LIFTING CAPACITIES. The ability to telescope loads is limited by hydraulic pressure, boom angle, boom length, crane maintenance, etc.
16. For lifting capacity of single top, reduce the rated lifting capacities of relevant boom by the weight of the main hook block. Capacities of single top shall not exceed 6,600lbs. (3,000kg) including main hook.
17. When erecting and stowing jib, be sure to retain it by hand or by other means to prevent its free movement.
18. 1,650lbs. (750kg) shall be subtracted from the rated lifting capacities of the main boom, when jib is attached to main boom head. Jib weight is 840lbs. (380kg).
19. Use "OVERWIND CUTOFF" disable switch when erecting and stowing jib and when stowing hook block. While the switch is pushed, the hoist does not stop, even when overwind condition occurs.
20. For boom length with 24.6' (7.5m) jib, rated lifting capacities are determined by boom length and loaded boom angle. For angles not shown, use the next lower loaded boom angle to determine allowable capacity. When boom length is between values listed, refer to the rated lifting capacities of next longer boom for the same angle. However, as for the capacity of 31' (9.45m) boom and 42' (12.8m) boom is the same as the capacities of 53' (16.15m) boom.
21. When lifting a load by using jib (aux.winch) and boom (main winch) simultaneously, do the following :
  - Enter the operation status as jib operation, not as boom operation.
  - Before starting operation, make sure that weight of load is within rated lifting capacity for jib.

## DEFINITIONS

1. Load Radius : Horizontal distance from a projection of the axis of rotation to supporting surface before loading to the center of the vertical hoist line or tackle with load applied.
2. Loaded Boom Angle : The angle between the boom base section and the horizontal, after lifting the rated lifting capacity at the load radius.
3. Working Area : Area measured in a circular arc about the centerline of rotation.
4. Freely Suspended Load : Load hanging free with no direct external force applied except by the hoist line.
5. Side Load : Horizontal side force applied to the lifted load either on the ground or in the air.



# TR-300XL-3 RATED LIFTING CAPACITIES (IN POUNDS)

TIRE : 20.5-25-24PR

ON RUBBER									
Load Radius in Feet	Stationary						Creep		
	Over Front			360° Rotation			Over Front		
	Boom Length in Feet			Boom Length in Feet			Boom Length in Feet		
	31' (9.45 m)	53' (16.15m)	76' (23.16m)	31' (9.45 m)	53' (16.15m)	76' (23.16m)	31' (9.45 m)	53' (16.15m)	76' (23.16m)
10'	37,300	32,700		22,000	16,200		31,200	26,800	
12'	35,800	32,700	15,300	16,100	16,200	12,100	26,900	26,800	15,300
15'	29,600	28,200	15,300	11,000	11,300	12,100	21,850	21,900	15,300
20'	18,150	18,150	14,500	6,300	6,700	7,000	16,100	16,000	14,500
25'	11,750	11,750	12,600	3,350	3,900	4,850	11,750	11,750	12,600
30'		8,300	9,750		2,000	3,100		8,300	9,750
35'		6,100	7,200			1,700		6,100	7,200
40'		4,450	5,400					4,450	5,400
45'		3,200	4,050					3,200	4,050
50'			3,200						3,200
55'			2,400						2,400
60'			1,750						1,750
65'			1,200						1,200
A		0°		0°	43°	55°		0°	13°

A : Minimum boom angle (deg.) for indicated length (no load)

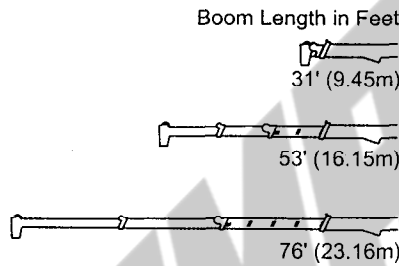
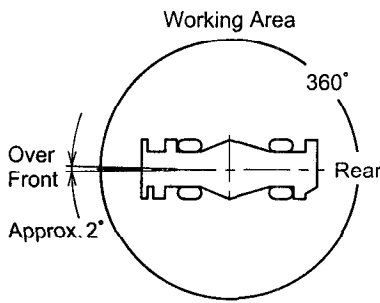

**NOTE :** Standard number of parts of line for on rubber operation should be according to the following table.

The lifting capacity data stored in the LOAD MOMENT INDICATOR (AML-L) is based on the standard number of parts of line listed in the chart.

Boom Length in Feet (meters)	31' (9.45)	31' to 53' (9.45 to 16.15)	53' to 76' (16.15 to 23.16)	single top
No. of parts of line	6	6 (4) *	4	1

\* : Stationary 360° Rotation requires 4 parts of line.

## WARNING AND OPERATING INSTRUCTIONS FOR ON RUBBER CAPACITIES

- Rated lifting capacities on rubber are in pounds and do not exceed 75% of tipping loads as determined by SAE J765 - Crane Stability Test Code.
- Rated lifting capacities shown in the chart are based on condition that crane is set on firm level surfaces with suspension lock applied. Those above bold lines are based on tire capacity and those below, on crane stability. They are based on actual load radius increased by tire deformation and boom deflection.
- Rated lifting capacities are based on proper tire inflation, capacity and condition. Damaged tires are hazardous to safe operation of crane.
- Tires shall be inflated to correct air pressure.
 

Tires	Air Pressure
20.5-25-24PR	93 psi. (6.5kgf/cm <sup>2</sup> )
- Over front operation shall be performed within two degrees in front of chassis.
- On rubber lifting with "jib" is not permitted. Maximum permissible boom length is 76 ft. (23.16m).
- When making lift on rubber stationary, set parking brake.
- For creep operation, boom must be centered over front of machine, swing lock engaged, and load restrained from swinging. Travel slowly and keep the lifted load as close to the ground as possible, and especially avoid any abrupt steering, accelerating or braking.
- Do not operate the crane while carrying the load.
- Creep is motion for crane not to travel more than 200 ft. (60m) in any 30 minute period and to travel at the speed of less than 1 mph (1.6 km/h).
- For creep operation, set drive select switch to "4-WHEEL (Lo) " and set gear shift lever to "1".

# WARNING AND OPERATING INSTRUCTIONS FOR USING THE LOAD MOMENT INDICATOR (AML-L)

1. When operating crane on outriggers :

- Set P.T.O. switch to "ON".
- Press the outrigger mode select key to register for the outrigger operation. The outrigger mode indicative symbol changes from flickering to lighting.
- Press the boom mode select key to register the boom mode. Each time the boom mode select key is pressed, the mode changes. Select the status that corresponds to the actual state of the boom.
- When erecting and stowing jib, select the status of jib set (Jib state indicative symbol flickers).

2. When operating crane on rubber :

- Set P.T.O. switch to "ON".
- Press the on-tire mode select key. The outrigger mode indicative symbol will disappear as the on-tire mode indicative symbol comes on. Each time the on-tire mode select key is pressed, the mode changes. Select the creep operation, the on-tire mode indicative symbol flickers.
- Press the boom mode select key to register the boom mode.

However, pay attention to the following :

(1) For stationary operation :

- The front capacities are attainable only when the over front position symbol comes on. When the boom is more than 2 degrees from centered over front of chassis, 360° capacities are in effect.
- When a load is lifted in the front position and then swung to the side area, make sure the value of the LOAD MOMENT INDICATOR (AML-L) is below the 360° lifting capacity.

(2) For creep operation :

- The creep capacities are attainable only when boom is in the straight forward position of chassis and the over front position symbol is on. If boom is not in the straight forward position of chassis, never lift load.
3. A swing does not automatically stop even if the crane becomes overloaded.
  4. During crane operation, make sure that the displays on front panel are in accordance with actual operating conditions.
  5. The displayed values of LOAD MOMENT INDICATOR (AML-L) are based on freely suspended loads and make no allowance for such factors as the effect of wind, sudden stopping of loads, supporting surface conditions, inflation of tire, operating speed, side loads, etc. For safe operation, it is recommended when extending and lowering boom or swinging, lifted loads shall be appropriately reduced.
  6. LOAD MOMENT INDICATOR (AML-L) is intended as an aid to the operator. Under no condition should it be relied upon to replace use of capacity charts and operating instructions. Sole reliance upon LOAD MOMENT INDICATOR (AML-L) aids in place of good operating practice can cause an accident. The operator must exercise caution to assure safety.

TR-300XL-3 Axle Weight Distribution Chart

	Pounds			Kilograms		
	GVW	Front	Rear	GVW	Front	Rear
31.0'~98.4' (9.45m~30m) 4-section boom 24.6' (7.5m) single stage jib Main hoist with 607 ft. (185m) of 5/8" (16mm) diameter wire rope Aux. hoist with 279 ft. (85m) of 5/8" (16mm) diameter wire rope Mitsubishi 6D16-TLEA engine, 20.5×25-24PR tires Auxiliary lifting sheave (Single top) 30 ton (27.2 metric ton) 4 sheaves hook block 4.4 ton (4 metric ton) hook ball	59,120	32,560	26,560	26,815	14,766	12,049
Add : Air Conditioning	+250	+105	+145	+114	+48	+66
Remove : 1. 24.6' (7.5m) Single stage jib	-840	-1,680	+840	-380	-760	+380
2. Auxiliary lifting sheave (Single top)	-100	-243	+143	-45	-110	+65
3. 30 ton (27.2 metric ton) 4 sheave hook block	-600	-1,067	+467	-270	-480	+210
4. 4.4 ton (4 metric ton) hook ball	-220	-300	+80	-100	-136	+36