



TR-280XL

28 Ton Capacity (25.4 Metric Tons)

HYDRAULIC ROUGH TERRAIN CRANE

DIMENSIONS

(20.5 X 25 Tires)

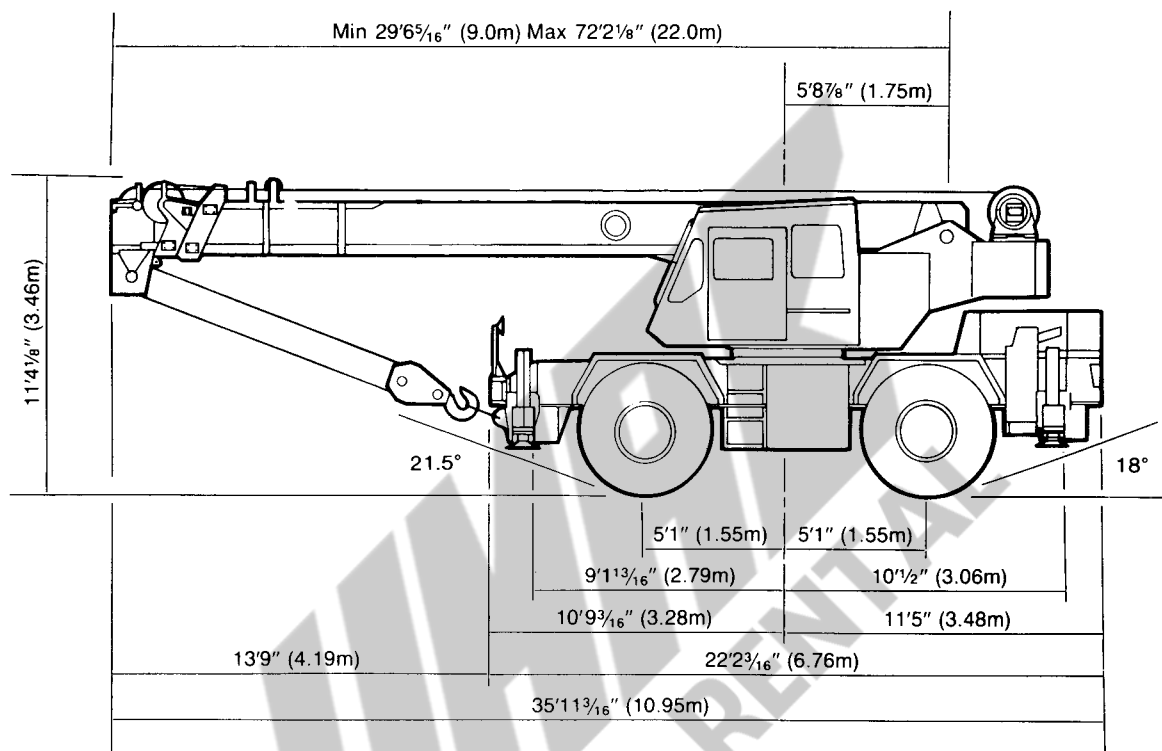

GENERAL DIMENSIONS

(20.5 X 25 Tires)

	Feet	Meters
Tail swing counterweight	9' 8 1/8"	2.95
Turning Radius:		
4 wheel steer	20' 11 3/4"	6.4
2 wheel steer	35' 9 1/8"	10.9

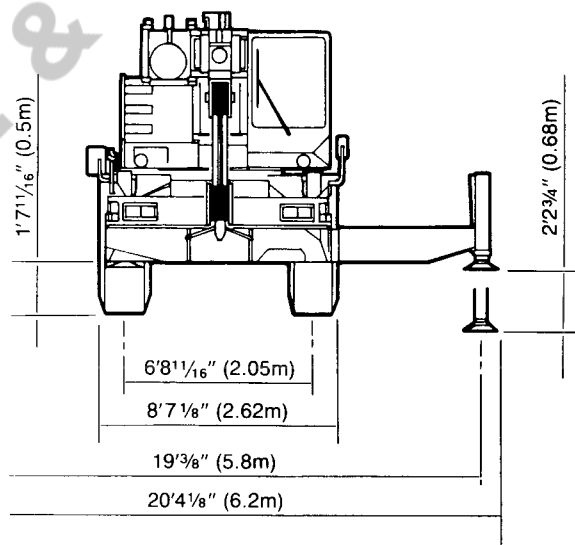

MDI/TADANO XL SERIES

Supplied by



CRANE SPECIFICATIONS

BOOM

Three section full power synchronized telescoping boom, 29.5'~72.2' (9.0~22.0m), of box construction with four sheaves, 12 5/8" (320 mm) root diameter, at boom head. The synchronization system consists of a telescope cylinder, an extension cable and retraction cable. Hydraulic cylinder fitted with holding valve. Two easily removable wire rope guards, rope dead end provided on right side of boom head. Boom telescope sections are supported by wear pads both vertically and horizontally.

BOOM ELEVATION - By a double acting hydraulic cylinder with holding valve. Elevation 0°~82°, combination controls for hand or foot operation. Boom angle indicator.

JIB - Single stage lattice type, 5°, 25°, or 45° offset (tilt type). Single sheave, 13 7/8" (352 mm) root diameter, at jib head. Stored along side base boom section. Jib length is 24.6' (7.5m)

AUXILIARY LIFTING SHEAVE (SINGLE TOP) - Optional. Single sheave, 12 5/8" (320 mm) root diameter. Mounted to main boom head for single line work. (Stowable.)

ANTI-TWO BLOCK - Pendant type over-winding cut out device with audio-visual (FAILURE lamp/BUZZER) warning system.

SWING

Hydraulic axial piston motor driven through planetary swing speed reducer. Continuous 360° full circle swing on ball bearing turntable at 3.4 rpm. Equipped with manually locked/released swing brake. A swing lock (pin-in-hole lock) for pick and carry and travel modes, manually engaged in cab.

HOIST

MAIN HOIST - Variable speed type with grooved drum driven by hydraulic axial piston motor through winch speed reducer. Power load lowering and raising. Equipped with automatic brake (Neutral brake) and counterbalance valve. Controlled independently of auxiliary hoist.

DRUM - Grooved 12 5/8" (320 mm) root diameter x 19 1/16" (0.4845 m) wide. Wire rope: 492 ft. of 5/8" diameter rope (150m of 16mm). Drum Capacity: 734 ft. (223.6m) 6 layers. Maximum line pull (permissible): 10, 078 lbs. (4,571 kg)*. Maximum line speed: 351 FPM (107 m/min).

AUXILIARY HOIST - Optional. Variable speed type with grooved drum driven by hydraulic axial piston motor through winch speed reducer. Power load lowering and raising. Equipped with automatic brake (neutral brake) and counterbalance valve. Controlled independently from main hoist.

DRUM - Grooved 12 5/8" (320 mm) root diameter x 10 3/8" (0.2635 m) wide. Wire rope: 223 ft. of 5/8" diameter rope (68m of 16mm). Drum capacity: 399 ft. (121.6m) 6 layers. Maximum line pull (permissible): 10, 078 lbs. (4,571 kg)*. Maximum line speed: 351 FPM (107m/min).

*Maximum permissible line pull may be affected by wire rope strength.

WIRE ROPE - Filler wire, extra improved plow steel, pre-formed, independent wire rope core, right regular lay.

5/8" (16mm) 6 x 37 class

5/8" (16mm) 19 x 7 class

19 x 7 is non-spin rope intended for single line work and is not recommended for multiple part reeving.

HOOK BLOCKS - Optional

1. 30 ton (27.2 metric ton) - 4 sheaves with swivel hook and safety latch, for 5/8" (16mm) wire rope.

2. 22 ton (20 metric ton)-3 sheaves with swivel hook and safety latch, for 5/8" (16mm) wire rope.

3. 4.4 ton (4.0 metric ton) - Weighted hook with swivel and safety latch, for 5/8" (16mm) wire rope.

HYDRAULIC SYSTEM

PUMPS - Tandem gear pump for telescope, elevation, and hoist. Tandem gear pump for swing, outriggers, steering and optional equipment. Powered by carrier engine. Pump disconnect for crane is engaged/disengaged by rotary switch from operator's cab.

CONTROL VALVES - Multiple valves actuated by hand levers with integral pressure relief valves.

RESERVOIR - 116 gallon (438 lit.) capacity. External sight level gauge.

FILTRATION - 26 micron return filter, full flow with bypass protection, located inside of hydraulic reservoir. Accessible for easy replacement.

CAB AND CONTROLS

Both crane and drive operations can be performed from one cab mounted on rotating superstructure.

Left side, 1 man type, steel construction with sliding door access and safety glass windows opening at side, rear and roof. Wind-shield glass window is shatter-resistant. Tilt-telescoping steering wheel. Adjustable control levers for swing, boom telescoping, boom hoist, auxiliary hoist and main hoist (with swing free-lock selector switch). Control levers for swing and boom hoist can change neutral positions and tilt for easy access to cab. Engine throttle knob. Foot operated controls: boom hoist, service brake and engine throttle.

Dash-mounted engine start/stop, monitor lamps, cigarette lighter, parking brake switch, steering mode select switch, rear steering lock switch.

Instruments - Torque converter oil temperature, engine water temperature, air pressure, fuel, hydraulic oil pressure, speedometer, tachometer and hour meter.

Tadano electronic LOAD MOMENT INDICATOR system (AML-M)

including:

- Control lever lockout function
- Working radius and/or boom angle preset function (warning only)
- Warning buzzer
- Boom angle/boom length/jib offset angle/working radius/rated loads/actual loads read out
- Ratio of actual load moment to rated load moment indication
- Working condition register switch
- External warning lamp

Operator's cab console includes transmission gear selector, pump engaged/disengaged switch, suspension spring lock switch, outrigger controls, sight level bubble, drive selector switch, swing free-lock selector switch, working light switch and ashtray. Swing lock knob, swing brake and 4 way adjustable seat with high back (with seat belt).

CARRIER SPECIFICATIONS

TYPE - Rear engine, left hand steering, driving axle 2-way selected type by manual switch, 4 x 2 front drive, 4 x 4 front and rear drive.

FRAME - High tensile steel, all welded box construction.

AUTOMATIC TRANSMISSION - Electronically controlled full automatic transmission. Torque converter driving full powershift with driving axle selector. 6 forward and 2 reverse speeds, constant mesh.

3 speeds - high range - 2 wheel drive; 4 wheel drive

3 speeds - low range - 4 wheel drive

MAXIMUM TRAVEL SPEED - 31.2 mph maximum.

AXLE - Front: Full floating type, steering and driving axle with planetary reduction. Rear: Full floating type, steering and driving axle with planetary reduction. Non-spin differential.

STEERING - Hydraulic power steering controlled by steering wheel. Three steering modes available: 2 wheel front, 4 wheel coordinated and 4 wheel crab.

SUSPENSION - Front: Semi-elliptic leaf springs with hydraulic lockout device. Rear: Semi-elliptic leaf springs with hydraulic lockout device

BRAKE SYSTEMS - Service: Air over hydraulic disc brakes on all 4 wheels. Parking/Emergency: Spring applied—air released brake acting on input shaft of front axle.

TIRES Standard 20.5 x 25-20 PR (OR),
Optional 16.0 x 25-20 PR (OR),

OUTRIGGERS - Four hydraulic, beam and jack outriggers. Vertical jack cylinders equipped with integral holding valve. Each outrigger beam and jack is controlled independently from cab. Beams extend to 19' 3/8" (5.8m) center-line and retract to within 8' 1 5/8" (2.48m) overall width with floats. Outrigger jack floats are attached thus eliminating the need of manually attaching and detaching them. Controls and sight bubble located in upper structure cab.

ENGINE

Model	Mitsubishi 6D14T
Type	Direct Injection Diesel
No. of cylinders	6
Combustion	4 cycle, turbo charged
Bore x Stroke, in. (mm)	4.331 x 4.527 (110 x 115)
Displacement, cu. in (liters)	400 (6.557)
Air inlet heater	24 volt preheat
Air cleaner	Dry type, replacement element (dual)
Oil filter	Full flow with replacement element
Fuel Filter	Full flow with replacement element
Fuel tank, gal. (liters)	66.0 (250), right side of carrier
Cooling	Liquid pressurized, recirculating by-pass

Radiator	Fin and tube core, thermostat controlled
Fan, in. (mm)	Blower type, 8-blade, 23.6 (600) dia.
Starting	24 volt
Charging	24 volt system, negative ground
Battery	2 - 140 amp. hour
Compressor, air, CFM (l/min)	21.3 CFM (602) at 2,000 rpm
Horsepower,(kW)	Net 180 (134) at 2600 rpm
Torque, Max. ft-lb (kgm)	420 (58) at 1600 rpm
Capacity, gal. (liters)	
Cooling water	3.4 (13)
Lubrication	3.7~4.2(14~16)

STANDARD EQUIPMENT

- Three section full power synchronized boom 29.5' - 72.2' (9.0m - 22.0m)
- Single stage stowable lattice jib 24.6' (7.5m) with 5°, 25°, 45° pinned offset (tilt type)
- Boom hoist foot control
- Boom angle indicator
- Variable speed main hoist driven by axial piston motor
- Tadano twin swing system
- 4 x 4 x 4 drive
- Hydraulic lockout suspension system
- Independently controlled outriggers
- Self-storing outrigger pads
- Electronic controlled automatic transmission driven by torque converter
- Complete highway light package
- Anti two block device (Overwind cutout)
- Electronic crane monitoring system
- Tadano electronic load moment indicator system (AML-M) including:
 - Control lever lockout function
 - Working radius and/or boom angle preset function (warning only)
 - Warning buzzer
 - Boom angle/boom length/jib offset angle/working radius/ rated loads/actual loads read out
 - Ratio of actual load moment to rated load moment indication
 - Working condition register switch
 - External warning lamp
- Front windshield wiper and washer
- Roof windshield wiper
- Roof windshield lock warning
- Rear view mirrors (right and left side)
- 4 way adjustable seat with high back

- Tilt-telescoping steering wheel
- Neutral position adjustable control lever (swing and boom hoist)
- Seat belt
- Cab floor mat
- Electric fan in cab
- Back up alarm
- Low oil pressure/high water temperature warning device (visual)
- Fenders
- Towing hooks - front and rear
- Lifting eyes
- Tool storage compartment
- Full instrumentation package
- Pump disconnect in operator's cab
- Non-spin rear differential
- Water separator with filter
- Flood lights
- Outrigger hose protection
- 24 volt electric system
- 24 volt start
- Tire inflation kit (with tire pressure gauge)

OPTIONAL EQUIPMENT

- Variable speed auxiliary hoist with cable follower
- Auxiliary lifting sheave (single top) stowable
- 30 ton (27.2 metric ton) 4 sheave hook block
- 4.4 ton (4 metric ton) hook ball and swivel
- Heater
- Optional tires 16.00 X 25 —20PR (OR)
- Fire extinguisher
- Tool kit
- Drum rotation indicator (thumper type) main and/or aux hoist

HOISTING SPECIFICATIONS

LINE SPEEDS AND PULLS

Layer	Speed	Main or auxiliary hoist - 12 5/8" (0.32 m) drum					
		Line Speeds ²		Line pulls			
		F.P.M	m/min	Available ¹		Permissible ⁴	
				Lbs.	kgf	Lbs.	kgf
1st	Low	118	36	11,086	5028	10,078	4571
	High	236	72				
2nd	Low	130	40	10,642	4827	9675	4388
	High	259	79				
3rd	Low	141	43	10,270	4658	9336	4235
	High	282	86				
4th	Low	153	47	9953	4515	9048	4104
	High	305	93				
5th	Low	164	50	9680	4391	8800	3992
	High	328	100				
6th ³	Low	176	54	9442	4283	8584	3893
	High	351	107				

¹Developed by machinery with first layer of wire rope, but not based on rope strength or other limitation in machinery or equipment.

²Line speeds based only on hook block, not loaded.

³Sixth layer of wire rope is not recommended for hoisting operations.

⁴Permissible line pull may be affected by wire rope strength.

DRUM WIRE ROPE CAPACITIES

Wire Rope Layer	Main Drum Grooved Lagging 5/8" (16 mm) wire rope				Aux. Drum Grooved Lagging 5/8" (16 mm) wire rope			
	Rope per layer		Total wire rope		Rope per layer		Total wire rope	
	Feet	Meters	Feet	Meters	Feet	Meters	Feet	Meters
1	99	30.1	99	30.1	54	16.4	54	16.4
2	108	32.9	207	63.0	59	17.9	113	34.3
3	117	35.8	324	98.8	64	19.5	117	53.8
4	127	38.7	451	137.5	69	21.0	245	74.8
5	136	41.6	588	179.1	74	22.6	320	97.4
6	146	44.5	734	223.6	79	24.2	399	121.6

DRUM DIMENSIONS

	MAIN		AUXILIARY	
	Inch	mm	Inch	mm
Root Diameter	12 5/8	320	12 5/8	320
Length	19 1/16	484.5	10 3/8	263.5
Flange Diameter	20 7/8	530	20 7/8	530

OPERATING RADIUS/LIFTING HEIGHT CHART

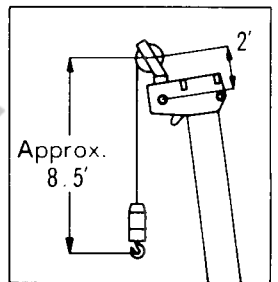
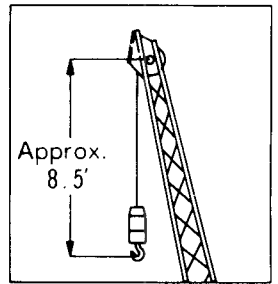
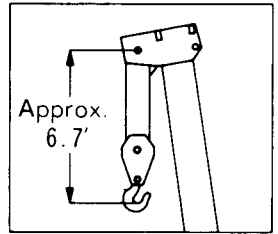
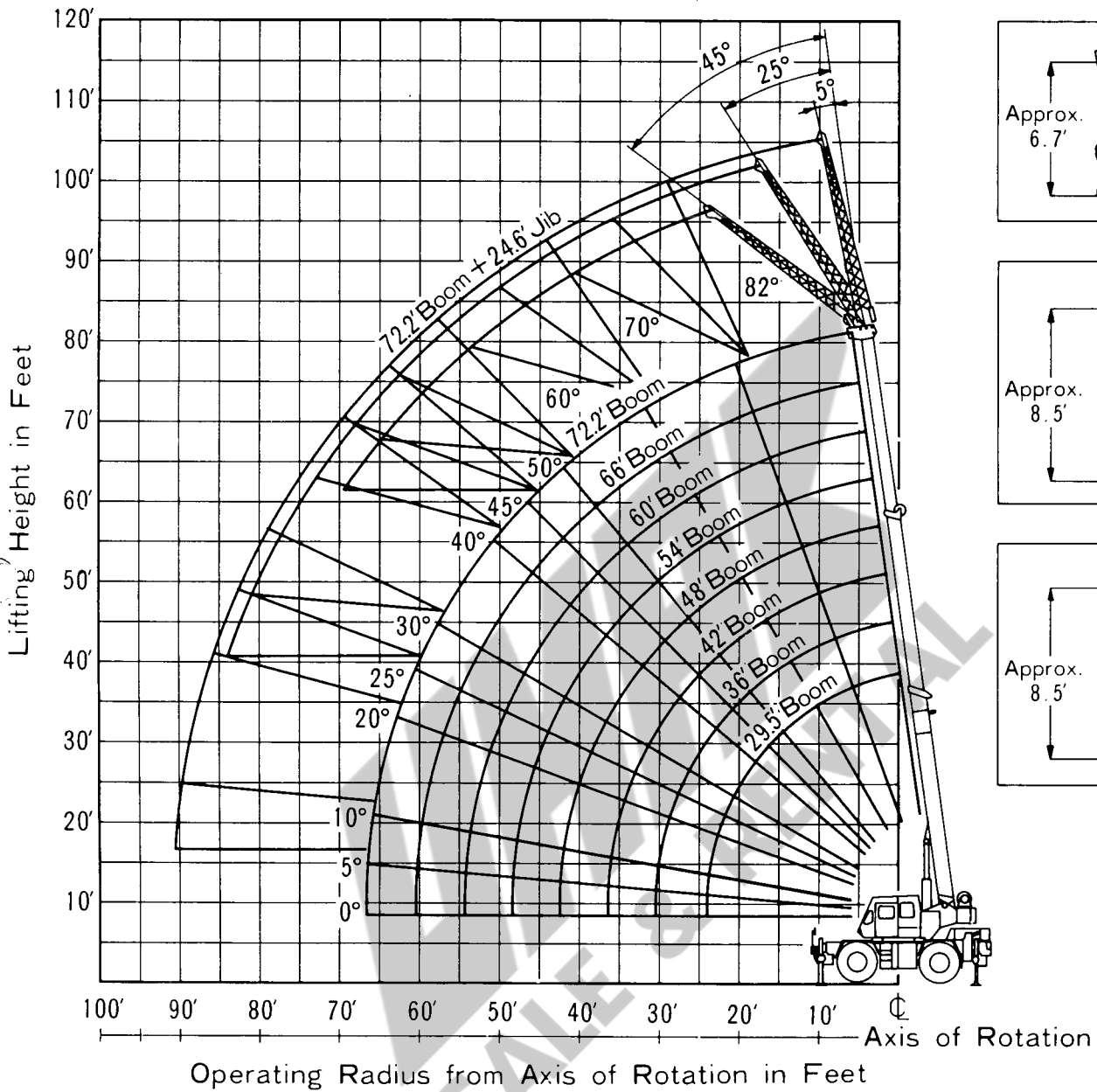

NOTE: Boom and jib geometry shown are for unloaded condition and machine standing level on firm supporting surface. Boom deflection and subsequent radius and boom angle change must be accounted for when applying load to hook.

TR-280XL TOTAL RATED LOAD CHART (IN POUNDS)

ON OUTRIGGERS FULLY EXTENDED 360° ROTATION												
Load Radius in Feet	Boom Length in Feet								Boom Angle in Degree	Boom Length in Feet		
	29.5 (9.0m)	36 (11.0m)	42 (12.8m)	48 (14.6m)	54 (16.5m)	60 (18.3m)	66 (20.1m)	72.2 (22.0m)		72.2 (22m) Boom + 24.6 (7.5m) Jib		
10	56,000 (60°)	36,000 (66°)	36,000 (70°)	35,000 (73°)	29,750 (75°)	29,150 (76°)	22,250 (77°)	20,850 (80°)	5° tilt	25° tilt	45° tilt	
12	40,000 (56°)	36,000 (62°)	36,000 (67°)	35,000 (70°)	29,750 (72°)	29,150 (74°)	22,250 (76°)	20,850 (77°)	80°	8,800	4,410	3,300
15	31,700 (48°)	31,500 (57°)	31,500 (62°)	31,200 (66°)	29,750 (69°)	29,150 (71°)	22,250 (73°)	20,850 (74°)	75°	8,260	4,410	3,300
20	24,000 (32°)	24,000 (47°)	24,000 (54°)	24,000 (59°)	24,000 (63°)	23,100 (66°)	22,250 (68°)	20,850 (70°)	70°	6,920	4,410	3,100
25		18,800 (34°)	18,800 (45°)	18,800 (52°)	18,800 (57°)	18,800 (61°)	18,300 (64°)	17,650 (66°)	65°	5,920	4,000	2,960
30		15,900 (9°)	15,900 (34°)	15,900 (44°)	15,900 (50°)	15,900 (55°)	15,300 (58°)	14,950 (61°)	60°	5,190	3,750	2,860
35			12,900 (16°)	12,900 (34°)	12,900 (43°)	12,900 (49°)	12,900 (53°)	12,700 (57°)	55°	4,590	3,560	2,760
40				10,800 (19°)	10,800 (34°)	10,800 (42°)	10,800 (47°)	10,800 (52°)	50°	4,090	3,400	2,660
45					9,020 (21°)	9,020 (34°)	9,020 (41°)	9,020 (46°)	45°	3,710	3,290	2,550
50						7,420 (23°)	7,420 (34°)	7,420 (41°)	40°	3,420	3,180	
55							6,200 (24°)	6,200 (34°)	35°	3,190	3,100	
60								5,200 (6°)	30°	2,820	2,800	
65								4,400 (12°)	25°	2,530	2,500	
									20°	2,300		
									15°	2,100		
									10°	1,900		
									5°	1,800		

1,650 lbs. (750 kg) shall be subtracted from the total rated load of the main boom when jib is attached to the main boom head.

WARNING AND OPERATING INSTRUCTIONS FOR LIFTING CAPACITIES

GENERAL

- Total rated loads shown on the TOTAL RATED LOAD CHART apply only to the machine as originally manufactured and normally equipped by TADANO LTD. Modifications to the machine or use of optional equipment other than that specified can result in a reduction of capacity.
- Construction equipment can be dangerous if improperly operated or maintained. Operation and maintenance of this machine must be in compliance with the information in the operation, safety and maintenance manual supplied with machine. If this manual is missing, order replacement through the distributor.
- The operator and other personnel associated with this machine shall fully acquaint themselves with the latest applicable American National Standards Institute (ANSI) safety standards for cranes.

SET UP

- Total rated loads shown on the chart are the maximum allowable crane capacities and are based on the machine standing level on firm supporting surface under ideal job conditions. Depending on the nature of the supporting surface, it may be necessary to have structural supports under the outrigger floats or tires to spread the load to a larger bearing surface.
- For outrigger operation, outriggers shall be fully extended with tires free of supporting surface before operating crane.

OPERATION

- Total rated loads with outriggers fully extended do not exceed 85% of the tipping loads as determined by SAE Crane Stability Test Code J-765.
- Total rated loads above bold lines in the chart are based on crane strength and those below, on its stability. They are based on actual load radius increased by boom deflection.
- Total rated loads include the weight of main hook block (600 lbs for 30 tons capacity), auxiliary hook ball (220 lbs for 4.4 tons capacity), sling and auxiliary lifting devices and their weights shall be subtracted from the listed capacities to obtain the net load to be lifted.
- Total rated loads are based on freely suspended loads and make no allowance for such factors as the effect of wind, sudden stopping of loads, supporting surface conditions, inflation of tires, operating speeds, side loads, etc. Side pull on boom or jib is extremely dangerous.
- Total rated loads do not account for wind on lifted load or boom. Total rated loads and boom length shall be appropriately reduced, when wind velocity is above 20 mph (9m/sec.).
- Total rated loads at load radius shall not be exceeded. Do not tip the crane to determine allowable loads.
- Do not operate at boom lengths beyond radii or boom angle, where no capacities are shown. Crane may overturn without any load on the hook.
- When boom length is between values listed, refer to the total rated loads of the next longer and next shorter booms for the same radius. The lesser of the two total rated loads shall be used.

- When making lifts at a load radius not shown, use the next longer radius to determine allowable capacity.
- Single line operation should not exceed 8,800 lbs (4000 kg).
- Loaded boom angles are approximate. The boom angle before loading should be greater to account for deflection.
- The 29.5' (9.0 m) boom length capacities are based on boom fully retracted. If not fully retracted [less than 36' (11.0 m) boom length], use the total rated loads for the 36' (11.0 m) boom length.
- Extension or retraction of the boom with loads may be attempted within the limits of the TOTAL RATED LOAD CHART. The ability to telescope loads is limited by hydraulic pressure, boom angle, boom length, crane maintenance, etc.
- For lifting capacity of single top, reduce the total rated loads of relevant boom by 550 lbs (250 kg). Capacities of single top shall not exceed 6,610 lbs (3000 kgs) including main hook.
- When erecting and stowing jib, be sure to retain it by hand or by other means to prevent its free movement.
- 1650 lbs (750 kgs) shall be subtracted from the total rated loads of the main boom, when jib is attached to main boom head. Jib weight is 770 lbs (350 kgs).
- Use Anti-Two Block (OVERWIND CUTOFF) disable switch when erecting and stowing the jib and stowing the hook block. While the switch is pushed, the hoist does not stop, even when overwind condition occurs.
- For boom lengths with 24.6' (7.5 m) Jib, total rated loads are determined by loaded boom angle only in the column headed "72.2' (22 m) Boom + 24.6' (7.5m) Jib". For boom angles not shown, use the next lower loaded boom angle to determine allowable capacity.
- When lifting a load by using jib (auxiliary hoist) and boom (main hoist) simultaneously, do the following:
 - Illuminate the jib indicator lamps and make the jib offset display screen indicate the same value as the actual offset by repeatedly pushing the boom state register switch.
 - Before starting operation, make sure that the weight of load is within the total rated load for jib.

DEFINITIONS

- Load Radius:** Horizontal distance from a projection of the axis of rotation to supporting surface before loading to the center of the vertical hoist line or tackle with load applied.
- Loaded Boom Angle:** The angle between the boom base section and the horizontal, after lifting the total rated load at the load radius.
- Working Area:** Area measured in a circular arc about the centerline of rotation.
- Freely Suspended Load:** Load hanging free with no direct external force applied except by the hoist line.
- Side Load:** Horizontal side force applied to the lifted load either on the ground or in the air.

Boom Length in Feet (meters)	29.5' (9.0)	36' to 60' (11.0 to 18.3)	66' to 72.2' (20.1 to 22.0)	On Rubber 29.5' to 72.2' (9.0 to 22.0)	Single top Jib
No. of part line	8	6	4	4	1

The lifting capacity data are stored in the Load Moment Indicator (AML-M) based on the standard number of parts of line listed in the above chart. Standard number of parts of line should be according to the above chart.

TIRE: 20.5 - 25 - 20PR

ON RUBBER			
Load Radius in Feet	Stationary		Creep
	Over Front	360° Rotation	Over Front
10	32,000(a)	23,700(f)	24,650(a)
12	27,800(a)	17,800(g)	21,200(a)
15	20,300(c)	12,400(h)	17,380(c)
20	13,470(d)	7,720(h)	13,470(d)
25	9,650(h)	5,220(h)	9,650(h)
30	7,250(h)	3,650(h)	7,250(h)
35	5,570(h)	2,600(h)	5,570(h)
40	4,350(h)	1,840(h)	4,350(h)
45	3,430(h)	1,250(h)	3,430(h)
50	2,730(h)		2,730(h)

NOTE: Boom angles are in degrees

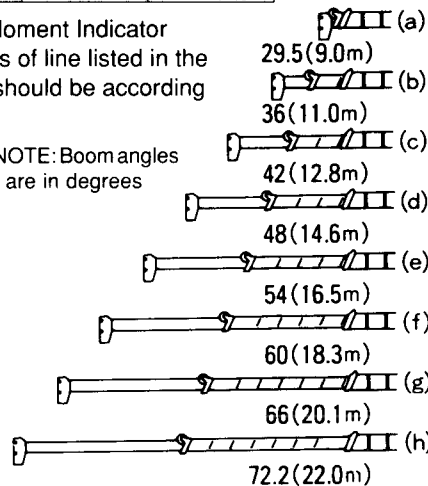

Boom Length in Feet Working Area

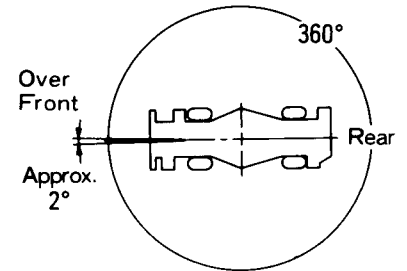

Max. Permissible Boom Length in Feet for On Rubber Lifting Capacities.

(a) 29.5 (9.0m)	(e) 54 (16.5m)
(b) 36 (11.0m)	(f) 60 (18.3m)
(c) 42 (12.8m)	(g) 66 (20.1m)
(d) 48 (14.6m)	(h) 72.2 (22.0m)

WARNING AND OPERATING INSTRUCTIONS FOR ON RUBBER CAPACITIES

- Total rated loads on rubber are in pounds and do not exceed 75% of tipping loads as determined by test in accordance with SAE J-765.
- Total rated loads shown in the chart are based on condition that crane is set on firm level surfaces with suspension lock applied. Those above bold lines are based on tire capacity and those below, on crane stability. They are based on actual load radius increased by tire deformation and boom deflection.
- Total rated loads are based on proper tire inflation, capacity and condition. Damaged tires are hazardous to safe operation of crane.
- Tires shall be inflated to correct air pressure.
- Over front operation shall be performed within two degrees in front of chassis.
- On rubber lifting with "jib" and "auxiliary lifting sheave" (single top) are not permitted.
- When making lift on rubber, set parking brake.
- For creep operation, boom must be centered over front of machine, swing lock engaged, and load restrained from swinging. Travel slowly and keep the lifted load as close to the ground as possible, and especially avoid any abrupt steering, accelerating or braking.
- Do not operate the crane while carrying the load.
- Creep is motion for crane not to travel more than 200 feet (60 m) in any 30 minute period and to travel at the speed of less than 1 mph (1.6 km/h).

TIRE AIR PRESSURE

16.00-25-20PR—79 psi (5.5 kgf/cm²)
20.50-25-20PR—80 psi (5.6 kgf/cm²)

WARNING AND OPERATING INSTRUCTIONS FOR USING THE LOAD MOMENT INDICATOR (AML-M)

Notes for Load Moment Indicator

- When operating crane on outriggers:
 - Set P.T.O. switch to "ON".
 - Push the outrigger state register switch to illuminate the outrigger indicator lamps.
 - Push the boom state register switch repeatedly until the state of the indicator lamps and the offset display screen conforms to the actual state of the boom, the single top and the jib.
 - When erecting and stowing jib, push boom state register switch repeatedly until jib indicator lamps flicker (in jib erection/stowing mode).
 - When operating crane on rubber:
 - Lock suspension springs with boom over front and crane in traveling configuration.
 - Set P.T.O. switch to "ON".
 - Push the boom state register switch repeatedly to illuminate the boom indicator lamp.
 - Push the on rubber state register switch to illuminate the on rubber indicator lamps. By repeatedly pushing the on rubber register switch, stationary and creep operation are selected alternately. When creep operation is selected, the on rubber indicator lamps flicker.
- However, pay attention to the following.
- For stationary operation.
 - The front capacities are attainable only when the over front indicator lamp is on. When the boom is more than 2 degrees from centered over front of chassis, 360° capacities are in effect.
 - When a load is lifted in the front position and then swung to the side area, make sure the value of the LOAD MOMENT INDICATOR (AML-M) is below the 360° lifting capacity.
 - For creep operation.
 - The creep capacities are attainable only when boom is in the straight forward position of chassis and the over front indicator is on. If boom is not in the straight forward position of chassis, never lift load.
 - During crane operation, make sure that the displays on front panel are in accordance with actual operating conditions.
 - The displayed values of LOAD MOMENT INDICATOR (AML-M) are based on freely suspended loads and make no allowance for such factors as the effect of wind, sudden stopping of loads, supporting surface conditions, inflation of tire, operating speed, side loads, etc. For safe operation, it is recommended when extending and lowering boom or swinging, lifting loads shall be appropriately reduced.
 - LOAD MOMENT INDICATOR (AML-M) is intended as an aid to the operator. Under no condition should it be relied upon to replace use of capacity charts and operating instructions. Sole reliance upon LOAD MOMENT INDICATOR (AML-M) aids in place of good operating practice can cause an accident. The operator must exercise caution to assure safety.

TR-280XL Axle Weight Distribution Chart

	Pounds			Kilograms		
	GVW	Front	Rear	GVW	Front	Rear
Basic standard machine includes: 29.5'—72.2' (9.0—22.0m) 3-section boom 24.6' (7.5m) jib main hoist with 492 ft (150m) of 5/8" (16mm) wire rope 30 ton (27.2 metric ton) hookblock 4.4 ton (4 metric ton) hookblock 4360 lbs. (2100kg) counterweight 882 lbs. (400kg) counterweight Mitsubishi 6D14T engine; 20.5 X 25—20 PR tires	51,545	25,926	25,619	23,381	11,760	11,621
Add: Auxiliary hoist with 223' (68m) of 5/8" (16mm) wire rope Auxiliary lifting sheave (single top)	+1,049 + 95	-172 +269	+1,221 - 174	+476 + 43	-78 +122	+554 - 79
Remove: 30 ton (27.2 metric ton) hookblock 4.4 ton (4 metric ton) hookblock 882 lbs. (400kg) counterweight	-600 -220 -882	-996 +102 +168	+396 -322 -1,050	-272 -100 -400	-452 + 46 + 76	+180 -146 -476

4630 lbs (2100kg) counterweight used with main hoist and auxiliary hoist.
 882 lbs. (400kg) counterweight used to add to 4630 lbs (2100 kg) with main hoist only.

SIMS CRANE & EQUIPMENT CO.
 POST OFFICE BOX 11825
 1219 U.S. HWY 301 NORTH
 TAMPA, FLORIDA 33680
 (813) 626-8102

MDI/TADANO HYDRAULIC CRANES
 Manufactured by TADANO LTD.

Distributed by

Machinery Distribution, Inc.
 A subsidiary of  Mitsubishi Corporation

2011 West Sam Houston Parkway North
 Houston, Texas 77043-2421
 Phone 713-467-1234 Fax 713-467-3232