



# TADANO HYDRAULIC TRUCK CRANE

SPEC. SHEET No. TG-700E-3-10101/EX-12

## TG-700E

CARRIER : KG54WXL

### GENERAL DATA

CRANE CAPACITY	70,000 kg at 3.0 m		
BOOM	5-section, 11.0 m — 42.0 m		
DIMENSIONS			
Overall length	approx.	13,950 mm	
Overall width	approx.	3,000 mm	
Overall height	approx.	3,880 mm	
WEIGHTS (excluding hook block of 15 ton capacity)			
Gross vehicle weight	approx.	47,200 kg	《43,200 kg》
—front	approx.	19,800 kg	《21,400 kg》
—rear	approx.	27,400 kg	《21,800 kg》
PERFORMANCE			
Max. travelling speed	computed	73 km/ h	
Gradeability(tan $\theta$ )	computed	29 %	《32 %》

### OPTIONAL EQUIPMENT

Counterweight dismounting device

Note: Specifications shown in the double parenthesis are based on the condition that counterweight is dismounted.

## CRANE SPECIFICATIONS

MODEL  
TG-700E

CAPACITY  
70,000 kg at 3.0 m

BOOM  
5-section full length power dual-synchronized telescoping boom of hexagonal box construction with 7 sheaves at boom head. The synchronization system consists of three telescope cylinders, an extension cable and a retraction cable.

Hydraulic cylinders fitted with holding valves.  
Fully retracted length..... 11.0 m  
Fully extended length..... 42.0 m  
Extension speed..... 31.0 m in 128 s

JIB  
2-staged swingaround boom extension. Dual offset(5°/30°)type. Box type top section telescopes from lattice type base section which stores alongside base boom section. Single sheave at jib head.  
Length..... 9.0 m and 16.0 m

SINGLE TOP (AUXILIARY BOOM SHEAVE)  
Single sheave. Mounted to main boom head for single line work.

ELEVATION  
By 2 double-acting hydraulic cylinders, fitted with holding valves.  
Elevation speed..... -2°to 83° in 67 s

# TADANO LTD.

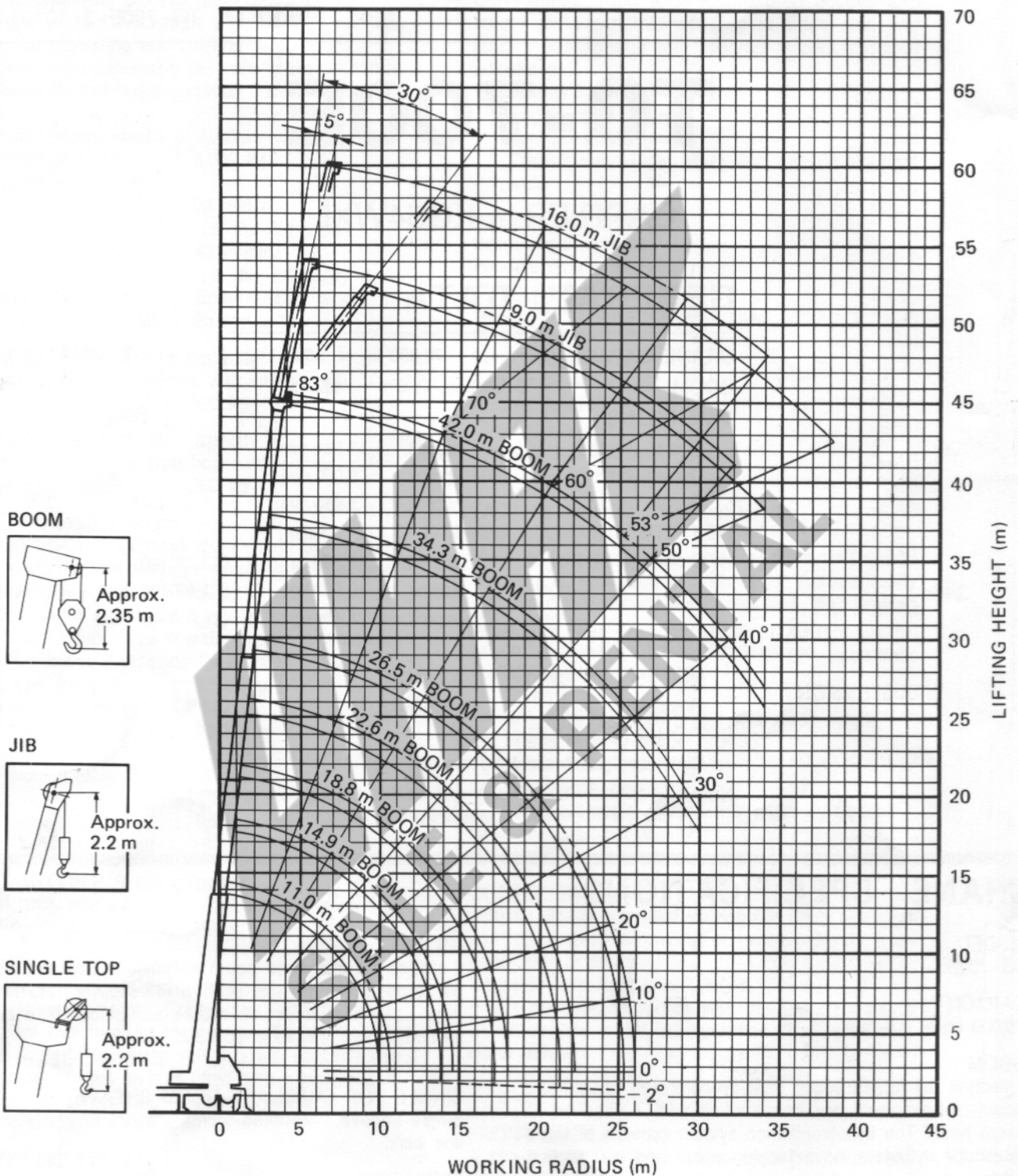

**NOTE:**

The above lifting heights and boom angles are based on a straight (unladen) boom, and allowance should be made for boom deflection obtained under laden conditions.

# TOTAL RATED LOADS

SPEC. SHEET No.TG-700E-3-10101/EX-12

With counterweight

Unit : kg

Outriggers fully extended														
Front jack extended (360°)														
Front jack not extended (Over sides and rear)														
B	A								E	C	9.0m		16.0m	
		11.0m	14.9m	18.8m	22.6m	26.5m	34.3m	42.0m			D	5°	30°	5°
3.0m	70,000	40,000	40,000	27,000					83°	4,500	2,500	2,500	1,200	
3.5m	60,000	40,000	40,000	27,000	23,000				80°	4,500	2,500	2,500	1,200	
4.0m	53,000	40,000	40,000	27,000	23,000				78°	4,000	2,300	2,300	1,100	
4.5m	46,500	40,000	40,000	27,000	23,000				75°	3,600	2,000	2,000	1,050	
5.0m	42,000	38,000	35,500	27,000	23,000	15,000			73°	3,300	1,800	1,830	1,000	
5.5m	37,500	34,700	32,300	25,000	23,000	15,000			70°	2,800	1,740	1,620	870	
6.0m	34,000	32,000	29,700	23,500	23,000	15,000			68°	2,500	1,650	1,500	840	
6.5m	30,500	29,000	27,500	22,300	21,800	15,000	8,000		65°	2,200	1,500	1,350	810	
7.0m	27,500	26,000	25,200	20,800	20,400	15,000	8,000		63°	2,000	1,410	1,270	780	
7.5m	24,800	24,000	23,300	19,500	19,100	15,000	8,000		60°	1,800	1,300	1,150	750	
8.0m	22,500	22,000	21,400	18,400	18,000	15,000	8,000		58°	1,700	1,200	1,050	700	
9.0m	18,200	18,000	18,000	16,500	16,000	13,400	8,000		55°	1,250	1,100	950	650	
10.0m		14,800	14,900	14,900	14,500	12,200	8,000		53°	1,050	950	750	600	
11.0m		12,500	12,500	12,500	12,400	11,000	8,000		50°	700	700			
12.0m		10,600	10,600	10,600	10,500	10,000	8,000							
14.0m			7,800	7,800	7,700	8,400	7,000							
16.0m			5,800	5,800	5,700	6,600	6,000							
18.0m				4,200	4,100	5,200	5,300							
20.0m				3,100	3,000	4,000	4,500							
22.0m					2,100	3,100	3,800							
24.0m					1,400	2,300	3,000							
26.0m						1,700	2,300							
28.0m						1,200	1,800							
30.0m						700	1,400							
32.0m							1,000							
34.0m							600							

- A : Boom length
- B : Working radius
- C : Jib length
- D : Jib offset
- E : Boom angle

With counterweight

Unit : kg

Outriggers fully extended									
Front jack not extended (Over front)									
B	A								Without outriggers (Over-rear)
		11.0m	14.9m	18.8m	22.6m	26.5m	34.3m	42.0m	
3.0m	45,000	35,000	27,000	20,000					8,000
3.5m	45,000	35,000	27,000	20,000	15,000				6,400
4.0m	43,000	35,000	27,000	20,000	15,000				5,100
4.5m	35,000	34,000	27,000	20,000	15,000				4,550
5.0m	28,000	28,000	27,000	20,000	15,000	10,000			4,050
5.5m	23,000	23,000	22,800	20,000	15,000	10,000			3,600
6.0m	19,400	19,300	19,100	18,600	15,000	10,000			3,150
6.5m	16,600	16,500	16,300	16,000	15,000	10,000	5,500		2,800
7.0m	14,300	14,100	14,000	13,900	13,400	10,000	5,500		2,400
7.5m	12,200	12,100	12,000	11,900	11,500	10,000	5,500		2,100
8.0m	10,600	10,400	10,300	10,300	10,200	10,000	5,500		1,800
9.0m	8,100	8,000	7,900	7,800	7,800	8,400	5,500		1,000
10.0m		6,200	6,100	6,100	6,000	6,900	5,500		
11.0m		4,900	4,800	4,700	4,600	5,600	5,500		
12.0m		3,800	3,700	3,600	3,500	4,500	5,300		
14.0m			2,000	2,000	1,900	2,900	3,700		
16.0m						1,700	2,500		
18.0m							1,600		

## WORKING AREA

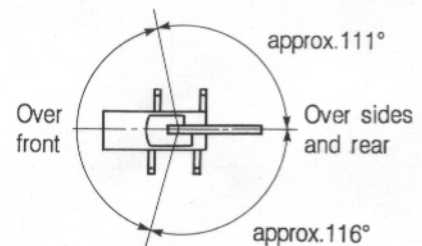

## WITHOUT OUTRIGGERS

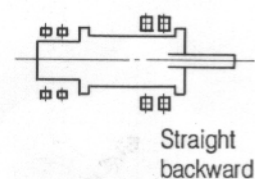

# TOTAL RATED LOADS

SPEC. SHEET No. TG-700E-3-10101/EX-12

## NOTES :

1. Total rated loads shown in the table are based on condition that the crane is set on firm ground horizontally. Those above bold lines are based on crane strength and those below, on its stability.
2. Total rated loads below bold lines do not exceed 75 % of tipping load.
3. Each total rated loads includes weight of the hooks and slings.
4. Without front jack extended, when the boom is within the Over-front, total rated loads are different from those for the boom in the Over-side and Over-rear.
5. Total rated loads for "Without outriggers" are based on the best condition of tire air pressure and ground surface.
6. Standard number of part lines for each boom length is as shown below. Load per line should not surpass 5,000 kg for main winch and 4,500 kg for auxiliary winch.

Boom length	11.0 m	14.9 m	18.8 m	22.6 m	26.5 m	34.3 m	42.0 m	Jib/Single top
No. of part lines	14	8	8	6	5	4	2	1

7. For total rated load of single top, reduce the main hook weight from the relevant boom total rated load. Total rated load of single top should not exceed 4,500 kg.
8. Free-fall operation should be performed without any load on the hook.

## DIMENSIONS

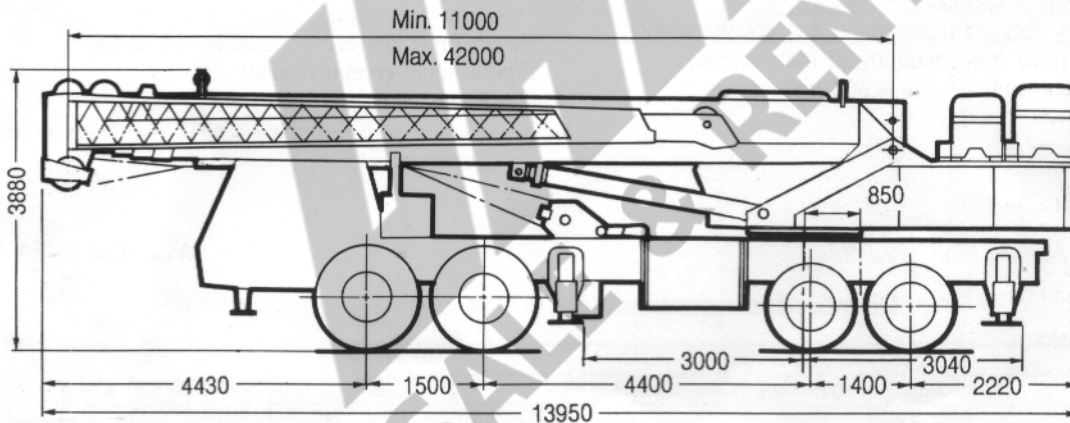

Overall width ..... 3,000 mm  
 Tail swing radius ..... 3,800 mm

Tread (track) – Front ..... 2,480 mm  
 – Rear ..... 2,280 mm