

# ALL TERRAIN CRANE

AR

## AR-1200M

(Luffing Jib)

*JAPANESE SPECIFICATIONS*

CARRIER MODEL	SPEC. NO.
FAUN RTF120-5	AR-1200M-1-90103

Control No. JA-02

# AR-1200M

## CRANE SPECIFICATIONS

### CRANE CAPACITY

12.2m Boom	120,000kg	at 2.7m	(17part-line)
21.0m Boom	50,000kg	at 7.0m	( 7part-line)
29.8m Boom	34,000kg	at 8.0m	( 5part-line)
38.7m Boom	24,000kg	at 10.0m	( 4part-line)
47.5m Boom	13,000kg	at 16.0m	( 4part-line)
9.8m Jib	7,000kg	at 73 °	( 1part-line)
15.4m Jib	3,800kg	at 70 °	( 1part-line)
21.0m Jib	2,500kg	at 68 °	( 1part-line)
11m Luffing jib	30,000kg	at 8.0m	( 4part-line)
19m Luffing jib	22,400kg	at 9.0m	( 3part-line)
27m Luffing jib	16,00kg	at 12.0m	( 2part-line)
35m Luffing jib	9,500kg	at 20.0m	( 2part-line)

### MAX. LIFTING HEIGHT

Boom: 47.5m Jlb: 68.0m Luffing jib: 77.0m

### MAX. WORKING RADIUS

Boom: 44.0m Jlb: 53.7m Luffing jib: 54.0m

### BOOM LENGTH

12.2m – 47.5m

### BOOM EXTENSION

35.3m

### BOOM EXTENSION SPEED

35.3m/110s

### JIB LENGTH

9.8m – 21.0m

### LUFFING JIB LENGTH

1.6m (fixing part) + 11m, 19m, 27m, 35m

### MAIN WINCH SINGLE LINE WINDING SPEED

135m/min (4th layer)

### MAIN WINCH HOOK SPEED

7.9m/min (17 part-line)

### AUXILIARY WINCH SINGLE LINE WINDING SPEED

135m/min (4th layer)

### AUXILIARY WINCH HOOK SPEED

135m/min (1 part-line)

### BOOM ELEVATION ANGLE

-2 °– 81.5 °

### BOOM ELEVATION SPEED

-2 °– 81.5 °/5s

### SWING ANGLE

360 °continue

### SWING SPEED

1.5rpm

### WIRE ROPE

Main Winch: 22mm x 255m (Diameter x Length)  
Anti-rotate wire rope

Auxiliary Winch: 22mm x 185m (Diameter x Length)  
Anti-rotate wire rope

### HOOK

120t hook (17part-line)  
50t hook ( 7part-line)  
8t hook ( 1part-line)

### BOOM

5-section hydraulically telescoping boom of box construction

Two telescoping methods selection type

Telescoping method I

(stages 2,3: synchronized; stages 4,5: synchronized)

Telescoping method II

(stages 2 – 5: synchronized)

### BOOM EXTENSION

3 double-acting hydraulic cylinders

1 wire rope type telescoping device

With flow regulator valve with pressure compensation

### JIB

Folding type which stores alongside the boom

3-section hydraulically synchronously telescoping boom

Hydraulic non-stage offset (5 °– 45 °) type

### SINGLE TOP

Single sheave. Mounted to main boom head for single line work.

### HOIST

Driven by hydraulic variable motor and via planetary gear reducer.

Automatic brake

2 single winches

With flow regulator valve with pressure compensation

### BOOM ELEVATION

1 double-acting hydraulic cylinder

With flow regulator valve with pressure compensation

### SWING

Hydraulic motor driven planetary gear reducer

Swing bearing

Manual switch brake

2-speed (high/low) selection type

### OUTRIGGERS

Fully hydraulic H-type

Slides and jacks each provided with independent operation device.

Fully extended width 8.0m

Middle extended width 7.0m, 5.3m, 4.6m

Extended width detector provided.

Slide storing float

### MAX. VERTICAL LOAD CAPACITY OF OUTRIGGER

83t

### ENGINE FOR CRANE

Engine exclusive to upper component operation

Model NISSAN NE6T

Type 4-cycle, 6 in-line cylinder, direct-injection, water-cooled diesel engine

Piston displacement 7,412cc

Max. output 180PS at 2,200rpm

Max. torque 69.0kg·m at 1,500rpm

### FUEL TANK CAPACITY

250 liters

### HYDRAULIC PUMPS

2 variable high-pressure piston pumps and 2 high-pressure gear pumps

### HYDRAULIC OIL TANK CAPACITY

1,000 liters

### SAFETY DEVICES

Automatic moment limiter (AML)

Multiple display

With working range limiting function

Outrigger extension automatic detector (individual detection)

Weight combination automatic detector

Swing range controller

Swing automatic stop device

Boom elevation slow down and stop device

Over-winding cutout device

Dead winding holding device

Cable follower

Hook safety latch

Winch drum lock

Hydraulic safety valve

Hydraulic lock (elevation, telescoping, hoist, jack, jib tilt, counterweight)

Swing lock

Boom angle indicator

Level gauge

### EQUIPMENT

Counterweight dismount device

Jib extension device

Oil cooler

Boom dismount device

Swing frame dismount device

AML external indication lamp

Hook movement amount indicator

Iron plate

Air conditioner

FM radio

Hot and cool boxes

Lunch table

### OPTIONAL EQUIPMENT

Swing alarm

Drum monitor

## CARRIER SPECIFICATIONS

### MANUFACTURER

FAUN GmbH

### CARRIER MODEL

RTF 120-5

### ENGINE

Model OM442LA (Benz)

Type 4-cycle, V8-cylinder, direct-injection, turbo diesel engine with inter cooler

Piston displacement 14,618cc

Max. output 503PS at 2,100rpm

Max. torque 206kg-m at 1,100 to 1,600rpm

### TRANSMISSION

Fully automatic

5-forward and 1-reverse speeds

Sub-transmission provided.

### CLUTCH

Torque converter provided.

Automatic lock-up mechanism provided.

### DRIVING METHOD

10 x 6

10 x 8 --- Off load (with def-lock mechanism)

### AXLE (all axles)

Full-floating type

### SUSPENSION (all axles)

Hydraulic pneumatic suspension

Stroke: +149mm/-113mm

### STEERING

Type: Left-side handle

Fully hydraulic power steering

2 circuits

Emergency power steering

Mode: Normal (6 front wheels)

Clamp (10 wheels)

Crab (10 wheels)

Rear steering (4 rear wheels)

### BRAKE SYSTEM

Service Brake

Air brake on all wheels

2 circuits

Parking Brake

4th and 5th axles (4-wheel) spring brake for public thoroughfare traveling

(3rd, 4th and 5th axles (6-wheel) spring brake for on-site traveling)

Emergency Brake

Works by applying the parking brake

Auxiliary Brake

Flow type retarder (transmission built-in)

Exhaust brake

### ELECTRIC SYSTEM

24 V DC. 2 batteries of 12V-170Ah

### FUEL TANK CAPACITY

570 liters

### CAB

Two-man type

### TIRES

16.00R25 (all wheels)

### WHEEL

11.25-25 (all wheels)

### STANDARD EQUIPMENT

Air conditioner

FM radio

Mud guard

Centralized lubrication unit

Bed for napping

### OPTIONAL EQUIPMENT

Back monitor

## GENERAL DATA

### DIMENSIONS (CARRIER ONLY)

Overall length 12,140mm

Overall width 3,000mm

Overall height 2,755mm

Wheel base 2,600mm + 1,700mm + 1,750mm + 1,650mm

Tread 2,557mm

### WEIGHTS (CARRIER ONLY)

Gross vehicle weight

Total 34,180kg (Two-man type)

Front: 1st + 2nd axle 17,280kg

Rear: 3rd axle 1,400kg

4th + 5th axle 15,500kg

### PERFORMANCE (CARRIER ONLY)

Max. traveling speed 70km/h

Gradeability (tan ) 0.70

Min. turning radius

6-wheel steering 11.9m

10-wheel steering 8.5m

Note:

1. The swing jib of this crane must be removed and transported separately from the carrier when running on public roads.

2. This crane is covered by Class C Conditions under the Basic Running Conditions of the Road Traffic Act.

<b>TOTAL RATED LOADS</b>
--------------------------

1. The total rated loads shown are for the case where the outriggers are set horizontally on firm level ground. The values above the bold lines are based on the crane strength while those below are based on the crane stability.
2. The weights of the slings and hooks (120t hook: 1,300kg , 50t hook: 600kg, 8t hook: 250kg) are included in the total rated loads shown.  
The boom-side attachment (100kg) is included.
3. The total rated load is based on the actual working radius including the deflection of the boom.
4. The table below shows the classification of Performances A to G of the total rated load.

Counterweight Outrigger extension width	22t	12t
8.0m	A	B
7.0m	C	D
5.3m	E	F
4.6m	F*	G*

Mark\* shows the performance of the boom.

5. The table below shows the standard number of part lines for each boom length. The load per line should not exceed 7.5t for the main winch and 8.0t for the auxiliary winch.

A	12.2m	21.0m	29.8m	38.7m	47.5m	J
H	(17)13	7	5	4	4	1

A= Boom length    H= No. of part-lines    J= Jib/Single top

The value in parenthesis is for the case where an attachment is used.

6. The total rated load for the single top shall be the value obtained by subtracting the weight of the hook mounted to the boom from the total rated load of the boom and must not exceed 8.0t.
7. Jib operation should be performed on the basis of the boom angle. The working radii are reference values for the case where a jib is mounted to a 47.5m boom.
8. The jib should be operated with the boom "telescoping method I".
9. When the maximum instantaneous velocity is 10m/s or more, stop crane operation.

## [BOOM]

Unit:ton

Performance A								
A \ B	12.2m	21.0m		29.8m		38.7m		47.5m
2.7m	120.0	50.0	21.0					
3.0m	110.0	50.0	21.0					
3.5m	98.0	50.0	21.0	34.0	21.0			
4.0m	91.0	50.0	21.0	34.0	21.0			
4.5m	84.0	50.0	21.0	34.0	21.0			
5.0m	77.0	50.0	21.0	34.0	21.0	24.0	21.0	
5.5m	69.0	50.0	21.0	34.0	21.0	24.0	21.0	
6.0m	63.0	50.0	21.0	34.0	21.0	24.0	21.0	13.0
6.5m	58.0	50.0	21.0	34.0	21.0	24.0	21.0	13.0
7.0m	53.0	50.0	21.0	34.0	21.0	24.0	21.0	13.0
8.0m	45.5	46.0	21.0	34.0	21.0	24.0	21.0	13.0
9.0m	39.5	40.0	21.0	31.2	21.0	24.0	21.0	13.0
10.0m		35.2	21.0	28.4	21.0	24.0	21.0	13.0
11.0m		31.2	21.0	25.9	21.0	22.6	20.7	13.0
12.0m		28.0	21.0	23.8	21.0	20.8	19.2	13.0
14.0m		21.7	21.0	20.3	21.0	18.0	16.7	13.0
16.0m		17.2	18.6	17.2	19.0	15.6	14.8	13.0
18.0m		13.9	15.2	13.9	15.7	13.7	13.2	12.0
20.0m				11.3	13.1	12.1	11.8	10.8
22.0m				9.3	11.1	10.6	10.7	9.7
24.0m				7.6	9.5	9.0	9.7	8.8
26.0m				6.1	8.1	7.6	8.4	8.0
28.0m						6.4	7.2	7.2
30.0m						5.3	6.2	6.4
32.0m						4.4	5.3	5.5
34.0m						3.6	4.5	4.7
36.0m						2.9	3.8	4.0
38.0m								3.4
40.0m								2.8
42.0m								2.3
44.0m								1.9
(°)	0~81.5	0~81.5	0~81.5	0~81.5	0~81.5	0~81.5	0~81.5	10~81.5
Boom stage telescoping condition (%)								
Telescoping method	I, II	I	II	I	II	I	II	I, II
2nd boom	0	50	25	100	50	100	75	100
3rd boom	0	50	25	100	50	100	75	100
4th boom	0	0	25	0	50	50	75	100
5th boom	0	0	25	0	50	50	75	100

A= Boom length B= Working radius  
 = Boom angle range (for the unladen condition)

## [BOOM]

Unit: ton

Performance B								
B \ A	12.2m	21.0m		29.8m		38.7m		47.5m
2.7m	100.0	50.0	21.0					
3.0m	97.0	50.0	21.0					
3.5m	88.0	50.0	21.0	34.0	21.0			
4.0m	80.0	50.0	21.0	34.0	21.0			
4.5m	73.0	50.0	21.0	34.0	21.0			
5.0m	67.5	50.0	21.0	34.0	21.0	24.0	21.0	
5.5m	62.5	50.0	21.0	34.0	21.0	24.0	21.0	
6.0m	58.0	50.0	21.0	34.0	21.0	24.0	21.0	13.0
6.5m	53.0	50.0	21.0	34.0	21.0	24.0	21.0	13.0
7.0m	49.0	49.5	21.0	34.0	21.0	24.0	21.0	13.0
8.0m	42.0	42.4	21.0	34.0	21.0	24.0	21.0	13.0
9.0m	36.5	36.8	21.0	31.2	21.0	24.0	21.0	13.0
10.0m		31.5	21.0	28.4	21.0	24.0	21.0	13.0
11.0m		26.6	21.0	25.9	21.0	22.6	20.7	13.0
12.0m		22.8	21.0	22.8	21.0	20.8	19.2	13.0
14.0m		17.3	18.6	17.2	19.2	18.0	16.7	13.0
16.0m		13.4	14.7	13.4	15.3	14.9	14.8	13.0
18.0m		10.6	11.9	10.6	12.5	12.0	12.7	12.0
20.0m				8.5	10.3	9.8	10.5	10.7
22.0m				6.6	8.5	8.1	8.8	8.9
24.0m				5.1	7.2	6.7	7.4	7.5
26.0m				3.8	6.0	5.4	6.2	6.4
28.0m						4.3	5.1	5.3
30.0m						3.4	4.2	4.4
32.0m						2.6	3.4	3.6
34.0m						1.9	2.8	2.9
36.0m						1.3	2.2	2.3
38.0m								1.8
40.0m								1.3
(°)	0~81.5	0~81.5	0~81.5	0~81.5	0~81.5	0~81.5	0~81.5	23~81.5
Boom stage telescoping condition (%)								
Telescoping method	I, II	I	II	I	II	I	II	I, II
2nd boom	0	50	25	100	50	100	75	100
3rd boom	0	50	25	100	50	100	75	100
4th boom	0	0	25	0	50	50	75	100
5th boom	0	0	25	0	50	50	75	100

A= Boom length B= Working radius  
= Boom angle range (for the unladen condition)

## [BOOM]

Unit:ton

Performance C								
A \ B	12.2m	21.0m		29.8m		38.7m		47.5m
2.7m	97.0	50.0	21.0					
3.0m	91.0	50.0	21.0					
3.5m	83.0	50.0	21.0	34.0	21.0			
4.0m	76.0	50.0	21.0	34.0	21.0			
4.5m	70.0	50.0	21.0	34.0	21.0			
5.0m	64.0	50.0	21.0	34.0	21.0	24.0	21.0	
5.5m	59.0	50.0	21.0	34.0	21.0	24.0	21.0	
6.0m	55.2	50.0	21.0	34.0	21.0	24.0	21.0	13.0
6.5m	51.5	50.0	21.0	34.0	21.0	24.0	21.0	13.0
7.0m	48.5	48.8	21.0	34.0	21.0	24.0	21.0	13.0
8.0m	42.7	43.0	21.0	34.0	21.0	24.0	21.0	13.0
9.0m	37.9	38.2	21.0	31.2	21.0	24.0	21.0	13.0
10.0m		34.2	21.0	28.4	21.0	24.0	21.0	13.0
11.0m		30.8	21.0	25.9	21.0	22.6	20.7	13.0
12.0m		27.6	21.0	23.8	21.0	20.8	19.2	13.0
14.0m		20.9	21.0	20.3	21.0	18.0	16.7	13.0
16.0m		16.3	17.7	16.3	18.3	15.6	14.8	13.0
18.0m		13.0	14.4	13.0	14.9	13.7	13.2	12.0
20.0m				10.5	12.4	11.9	11.8	10.8
22.0m				8.5	10.4	9.9	10.6	9.7
24.0m				6.8	8.8	8.3	9.0	8.8
26.0m				5.4	7.5	7.0	7.7	7.7
28.0m						5.8	6.5	6.6
30.0m						4.7	5.6	5.6
32.0m						3.8	4.7	4.7
34.0m						3.1	3.9	3.9
36.0m						2.5	3.3	3.3
38.0m								2.7
40.0m								2.1
42.0m								1.7
43.9m								1.3
(°)	0~81.5	0~81.5	0~81.5	0~81.5	0~81.5	0~81.5	0~81.5	12~81.5
Boom stage telescoping condition (%)								
Telescoping method	I, II	I	II	I	II	I	II	I, II
2nd boom	0	50	25	100	50	100	75	100
3rd boom	0	50	25	100	50	100	75	100
4th boom	0	0	25	0	50	50	75	100
5th boom	0	0	25	0	50	50	75	100

A= Boom length B= Working radius  
= Boom angle range (for the unladen condition)

## [BOOM]

Unit: ton

Performance D								
B \ A	12.2m	21.0m		29.8m		38.7m		47.5m
2.7m	95.0	50.0	21.0					
3.0m	89.0	50.0	21.0					
3.5m	81.0	50.0	21.0	34.0	21.0			
4.0m	74.0	50.0	21.0	34.0	21.0			
4.5m	68.0	50.0	21.0	34.0	21.0			
5.0m	62.0	50.0	21.0	34.0	21.0	24.0	21.0	
5.5m	58.0	50.0	21.0	34.0	21.0	24.0	21.0	
6.0m	53.8	50.0	21.0	34.0	21.0	24.0	21.0	13.0
6.5m	50.0	50.0	21.0	34.0	21.0	24.0	21.0	13.0
7.0m	46.8	47.1	21.0	34.0	21.0	24.0	21.0	13.0
8.0m	41.1	41.4	21.0	34.0	21.0	24.0	21.0	13.0
9.0m	36.4	36.7	21.0	31.2	21.0	24.0	21.0	13.0
10.0m		30.1	21.0	28.4	21.0	24.0	21.0	13.0
11.0m		25.0	21.0	24.9	21.0	22.6	20.7	13.0
12.0m		21.2	21.0	21.1	21.0	20.8	19.2	13.0
14.0m		15.7	17.2	15.7	17.8	17.1	16.7	13.0
16.0m		12.0	13.4	11.9	13.9	13.4	14.2	13.0
18.0m		9.1	10.6	9.2	11.2	10.7	11.4	11.4
20.0m				7.1	9.1	8.6	9.3	9.3
22.0m				5.3	7.4	6.9	7.6	7.7
24.0m				3.9	6.1	5.5	6.3	6.4
26.0m				2.7	4.9	4.3	5.2	5.2
28.0m						3.3	4.1	4.2
30.0m						2.4	3.3	3.3
32.0m						1.7	2.6	2.6
34.0m						1.1	1.9	2.0
36.0m							1.3	1.4
(°)	0~81.5	0~81.5	0~81.5	0~81.5	0~81.5	12~81.5	0~81.5	34~81.5
Boom stage telescoping condition (%)								
Telescoping method	I, II	I	II	I	II	I	II	I, II
2nd boom	0	50	25	100	50	100	75	100
3rd boom	0	50	25	100	50	100	75	100
4th boom	0	0	25	0	50	50	75	100
5th boom	0	0	25	0	50	50	75	100

A= Boom length B= Working radius  
= Boom angle range (for the unladen condition)



## [BOOM]

Unit:ton

Performance E								
B \ A	12.2m	21.0m		29.8m		38.7m		47.5m
2.7m	83.0	50.0	21.0					
3.0m	78.0	50.0	21.0					
3.5m	71.0	50.0	21.0	34.0	21.0			
4.0m	65.0	50.0	21.0	34.0	21.0			
4.5m	60.0	50.0	21.0	34.0	21.0			
5.0m	55.0	50.0	21.0	34.0	21.0	24.0	21.0	
5.5m	51.0	50.0	21.0	34.0	21.0	24.0	21.0	
6.0m	47.5	48.0	21.0	34.0	21.0	24.0	21.0	13.0
6.5m	44.5	44.8	21.0	34.0	21.0	24.0	21.0	13.0
7.0m	41.6	41.8	21.0	34.0	21.0	24.0	21.0	13.0
8.0m	36.5	36.8	21.0	34.0	21.0	24.0	21.0	13.0
9.0m	31.2	31.5	21.0	31.2	21.0	24.0	21.0	13.0
10.0m		26.2	21.0	26.0	21.0	24.0	21.0	13.0
11.0m		22.1	21.0	22.0	21.0	22.6	20.7	13.0
12.0m		18.9	20.4	18.9	20.9	20.2	19.2	13.0
14.0m		14.2	15.6	14.2	16.2	15.6	16.3	13.0
16.0m		11.0	12.3	10.9	12.8	12.3	13.0	13.0
18.0m		8.6	9.9	8.5	10.3	9.9	10.6	10.5
20.0m				6.5	8.4	8.0	8.7	8.7
22.0m				4.8	6.9	6.4	7.1	7.2
24.0m				3.5	5.7	5.1	5.9	6.0
26.0m				2.4	4.5	3.9	4.8	4.8
28.0m						3.0	3.8	3.9
30.0m						2.2	3.0	3.1
32.0m						1.5	2.3	2.4
34.0m							1.7	1.7
36.0m							1.1	1.2
(°)	0~81.5	0~81.5	0~81.5	0~81.5	0~81.5	22~81.5	0~81.5	34~81.5
Boom stage telescoping condition (%)								
Telescoping method	I, II	I	II	I	II	I	II	I, II
2nd boom	0	50	25	100	50	100	75	100
3rd boom	0	50	25	100	50	100	75	100
4th boom	0	0	25	0	50	50	75	100
5th boom	0	0	25	0	50	50	75	100

A= Boom length B= Working radius  
= Boom angle range (for the unladen condition)

## [BOOM]

Unit: ton

Performance F								
B \ A	12.2m	21.0m		29.8m		38.7m		47.5m
2.7m	73.0	50.0	21.0					
3.0m	70.0	50.0	21.0					
3.5m	67.0	50.0	21.0	34.0	21.0			
4.0m	61.0	50.0	21.0	34.0	21.0			
4.5m	56.0	50.0	21.0	34.0	21.0			
5.0m	51.5	50.0	21.0	34.0	21.0	24.0	21.0	
5.5m	47.7	48.0	21.0	34.0	21.0	24.0	21.0	
6.0m	44.3	44.6	21.0	34.0	21.0	24.0	21.0	13.0
6.5m	41.3	41.6	21.0	34.0	21.0	24.0	21.0	13.0
7.0m	37.9	38.4	21.0	34.0	21.0	24.0	21.0	13.0
8.0m	29.3	29.7	21.0	29.7	21.0	24.0	21.0	13.0
9.0m	23.4	23.8	21.0	23.8	21.0	24.0	21.0	13.0
10.0m		19.5	21.0	19.5	21.0	21.1	21.0	13.0
11.0m		16.2	17.7	16.2	18.3	17.8	18.6	13.0
12.0m		13.6	15.1	13.6	15.7	15.2	16.0	13.0
14.0m		9.9	11.2	9.9	11.8	11.3	12.0	12.1
16.0m		7.3	8.6	7.3	9.0	8.6	9.3	9.4
18.0m		5.1	6.7	5.1	7.1	6.7	7.4	7.4
20.0m				3.4	5.6	5.0	5.9	5.9
22.0m				2.1	4.3	3.7	4.5	4.6
24.0m				1.0	3.2	2.6	3.4	3.5
26.0m					2.3	1.7	2.5	2.6
28.0m							1.7	1.8
(°)	0~81.5	0~81.5	0~81.5	22~81.5	0~81.5	41~81.5	36~81.5	50~81.5
Boom stage telescoping condition (%)								
Telescoping method	I, II	I	II	I	II	I	II	I, II
2nd boom	0	50	25	100	50	100	75	100
3rd boom	0	50	25	100	50	100	75	100
4th boom	0	0	25	0	50	50	75	100
5th boom	0	0	25	0	50	50	75	100

A= Boom length B= Working radius  
= Boom angle range (for the unladen condition)

## [BOOM]

Unit:ton

Performance G								
B \ A	12.2m	21.0m		29.8m		38.7m		47.5m
2.7m	71.0	50.0	21.0					
3.0m	68.0	50.0	21.0					
3.5m	64.5	50.0	21.0	34.0	21.0			
4.0m	59.0	50.0	21.0	34.0	21.0			
4.5m	54.0	50.0	21.0	34.0	21.0			
5.0m	49.5	50.0	21.0	34.0	21.0	24.0	21.0	
5.5m	45.8	46.3	21.0	34.0	21.0	24.0	21.0	
6.0m	39.9	40.2	21.0	34.0	21.0	24.0	21.0	13.0
6.5m	34.6	34.6	21.0	34.0	21.0	24.0	21.0	13.0
7.0m	29.7	30.1	21.0	29.8	21.0	24.0	21.0	13.0
8.0m	23.1	23.5	21.0	23.3	21.0	24.0	21.0	13.0
9.0m	18.4	18.7	20.5	18.7	20.9	20.2	21.0	13.0
10.0m		15.4	16.9	15.3	17.5	16.8	17.6	13.0
11.0m		12.7	14.1	12.7	14.7	14.1	14.9	13.0
12.0m		10.6	12.0	10.6	12.5	12.0	12.8	12.7
14.0m		7.5	8.8	7.5	9.3	8.9	9.5	9.6
16.0m		5.0	6.5	5.0	7.0	6.6	7.2	7.3
18.0m		3.1	4.7	3.1	5.3	4.7	5.5	5.6
20.0m					3.8	3.2	4.1	4.2
22.0m					2.6		2.9	3.0
(°)	0~81.5	0~81.5	0~81.5	44~81.5	31~81.5	50~81.5	46~81.5	56~81.5
Boom stage telescoping condition (%)								
Telescoping method	I, II	I	II	I	II	I	II	I, II
2nd boom	0	50	25	100	50	100	75	100
3rd boom	0	50	25	100	50	100	75	100
4th boom	0	0	25	0	50	50	75	100
5th boom	0	0	25	0	50	50	75	100

A= Boom length B= Working radius  
= Boom angle range (for the unladen condition)

[JIB]  
Performance A

Unit:ton

C D	47.5m Boom + 9.8m Jib						47.5m Boom + 15.4m Jib					
	5 °		25 °		45 °		5 °		25 °		45 °	
E ( ° )	B(m)	M	B(m)	M	B(m)	M	B(m)	M	B(m)	M	B(m)	M
81.5	8.2	7.00	11.3	6.50	13.2	3.90	9.3	3.80	14.2	3.10	17.6	1.95
80	10.5	7.00	13.5	6.50	15.2	3.90	11.7	3.80	16.5	3.10	19.8	1.95
78	12.7	7.00	15.7	6.50	17.2	3.90	14.2	3.80	18.8	3.10	21.9	1.95
75	16.1	7.00	18.8	6.20	20.1	3.75	17.8	3.80	22.1	2.90	24.9	1.85
73	18.2	7.00	20.7	5.80	22.0	3.65	20.1	3.80	24.2	2.80	26.9	1.80
70	21.3	6.50	23.6	5.25	24.8	3.50	23.6	3.80	27.4	2.65	29.7	1.74
68	23.2	6.00	25.4	4.90	26.6	3.45	25.8	3.70	29.4	2.55	31.6	1.70
65	26.0	5.20	28.1	4.45	29.2	3.35	28.9	3.40	32.3	2.45	34.3	1.64
63	27.8	4.80	29.9	4.20	30.9	3.30	30.9	3.25	34.3	2.40	36.0	1.61
60	30.3	4.15	32.3	3.70	33.3	3.20	33.9	3.05	37.0	2.35	38.5	1.57
58	32.0	3.80	33.9	3.40	34.8	3.15	35.8	2.95	38.8	2.30	40.1	1.55
55	34.4	3.30	36.2	3.00	37.0	2.85	38.5	2.70	41.3	2.20	42.3	1.53
53	35.9	3.00	37.6	2.70	38.3	2.60	40.2	2.45	42.9	2.15	43.8	1.50
50	38.1	2.35	39.6	2.15	40.2	2.05	42.5	1.95	45.0	1.70	45.8	1.45
48	39.4	1.90	40.9	1.75	41.4	1.65	44.0	1.60	46.3	1.40	47.0	1.25
45	41.4	1.35	42.7	1.25			46.0	1.10	48.2	0.95		
( ° )	44 ~ 81.5		44 ~ 81.5		47 ~ 81.5		44 ~ 81.5		44 ~ 81.5		47 ~ 81.5	

Unit:ton

C D	47.5m Boom + 21.0m Jib					
	5 °		25 °		45 °	
E ( ° )	B(m)	M	B(m)	M	B(m)	M
81.5	10.6	2.50	17.4	1.85	22.2	1.00
80	13.2	2.50	19.9	1.85	24.4	1.00
78	15.9	2.50	22.4	1.85	26.6	1.00
75	19.8	2.50	25.9	1.75	29.8	1.00
73	22.4	2.50	28.2	1.65	31.9	1.00
70	26.2	2.50	31.5	1.55	34.9	1.00
68	28.6	2.50	33.6	1.50	36.8	0.98
65	32.0	2.25	36.8	1.45	39.6	0.94
63	34.2	2.10	38.8	1.40	41.4	0.92
60	37.4	1.95	41.7	1.35	43.9	0.90
58	39.4	1.85	43.6	1.30	45.5	0.89
55	42.4	1.70	46.2	1.26	47.8	0.87
53	44.2	1.60	47.9	1.23	49.3	0.86
50	47.0	1.50	50.3	1.20	51.3	0.85
48	48.6	1.30	51.8	1.10	52.5	0.84
45	50.8	0.85	53.7	0.80		
( ° )	44 ~ 81.5		44 ~ 81.5		47 ~ 81.5	

B= Working radius C= Jib length D= Jib offset  
 E= Boom angle M= Total rated loads  
 = Boom angle range (for the unladen condition)

## [JIB]

## Performance B

Unit:ton

C D	47.5m Boom + 9.8m Jib						47.5m Boom + 15.4m Jib					
	5 °		25 °		45 °		5 °		25 °		45 °	
E ( ° )	B (m)	M	B (m)	M	B (m)	M	B (m)	M	B (m)	M	B (m)	M
81.5	8.2	7.00	11.3	6.50	13.2	3.90	9.3	3.80	14.2	3.10	17.6	1.95
80	10.5	7.00	13.5	6.50	15.2	3.90	11.7	3.80	16.5	3.10	19.8	1.95
78	12.7	7.00	15.7	6.50	17.2	3.90	14.2	3.80	18.8	3.10	21.9	1.95
75	16.1	7.00	18.8	6.20	20.1	3.75	17.8	3.80	22.1	2.90	24.9	1.85
73	18.2	7.00	20.7	5.80	22.0	3.65	20.1	3.80	24.2	2.80	26.9	1.80
70	21.3	6.50	23.6	5.25	24.8	3.50	23.6	3.80	27.4	2.65	29.7	1.74
68	23.2	6.00	25.4	4.90	26.6	3.45	25.8	3.70	29.4	2.55	31.6	1.70
65	26.0	5.20	28.1	4.45	29.2	3.35	28.9	3.40	32.3	2.45	34.3	1.64
63	27.7	4.65	29.9	4.15	30.9	3.30	30.9	3.25	34.3	2.40	36.0	1.61
60	30.1	3.40	32.1	3.05	33.2	2.85	33.8	2.85	37.0	2.35	38.5	1.57
58	31.6	2.70	33.6	2.40	34.6	2.25	35.5	2.25	38.6	1.85	40.1	1.55
55	33.9	1.80	35.7	1.60	36.6	1.45	37.9	1.45	40.8	1.20	42.2	1.00
53	35.3	1.30	37.0	1.10	37.8	1.00	39.4	1.00				
( ° )	52 ~ 81.5		52 ~ 81.5		52 ~ 81.5		52 ~ 81.5		54 ~ 81.5		54 ~ 81.5	

Unit:ton

C D	47.5m Boom + 21.0m Jib					
	5 °		25 °		45 °	
E ( ° )	B (m)	M	B (m)	M	B (m)	M
81.5	10.6	2.50	17.4	1.85	22.2	1.00
80	13.2	2.50	19.9	1.85	24.4	1.00
78	15.9	2.50	22.4	1.85	26.6	1.00
75	19.8	2.50	25.9	1.75	29.8	1.00
73	22.4	2.50	28.2	1.65	31.9	1.00
70	26.2	2.50	31.5	1.55	34.9	1.00
68	28.6	2.50	33.6	1.50	36.8	0.98
65	32.0	2.25	36.8	1.45	39.6	0.94
63	34.2	2.10	38.8	1.40	41.4	0.92
60	37.4	1.95	41.7	1.35	43.9	0.90
58	39.4	1.85	43.6	1.30	45.5	0.89
55	42.0	1.15	46.0	0.90		
53						
( ° )	54 ~ 81.5		54 ~ 81.5		57 ~ 81.5	

B= Working radius C= Jib length D= Jib offset  
 E= Boom angle M= Total rated loads  
 = Boom angle range (for the unladen condition)

[JIB]  
Performance C

Unit:ton

C D	47.5m Boom + 9.8m Jib						47.5m Boom + 15.4m Jib					
	5 °		25 °		45 °		5 °		25 °		45 °	
E ( ° )	B(m)	M	B(m)	M	B(m)	M	B(m)	M	B(m)	M	B(m)	M
81.5	8.2	7.00	11.3	6.50	13.2	3.90	9.3	3.80	14.2	3.10	17.6	1.95
80	10.5	7.00	13.5	6.50	15.2	3.90	11.7	3.80	16.5	3.10	19.8	1.95
78	12.7	7.00	15.7	6.50	17.2	3.90	14.2	3.80	18.8	3.10	21.9	1.95
75	16.1	7.00	18.8	6.20	20.1	3.75	17.8	3.80	22.1	2.90	24.9	1.85
73	18.2	7.00	20.7	5.80	22.0	3.65	20.1	3.80	24.2	2.80	26.9	1.80
70	21.3	6.50	23.6	5.25	24.8	3.50	23.6	3.80	27.4	2.65	29.7	1.74
68	23.2	6.00	25.4	4.90	26.6	3.45	25.8	3.70	29.4	2.55	31.6	1.70
65	26.0	5.20	28.1	4.45	29.2	3.35	28.9	3.40	32.3	2.45	34.3	1.64
63	27.8	4.80	29.9	4.20	30.9	3.30	30.9	3.25	34.3	2.40	36.0	1.61
60	30.3	4.15	32.3	3.70	33.3	3.20	33.9	3.05	37.0	2.35	38.5	1.57
58	32.0	3.80	33.9	3.40	34.8	3.15	35.8	2.95	38.8	2.30	40.1	1.55
55	34.3	2.80	36.0	2.55	36.9	2.40	38.4	2.35	41.2	2.00	42.3	1.53
53	35.7	2.25	37.4	2.05	38.2	1.95	39.9	1.90	42.6	1.60	43.8	1.45
50	37.8	1.55	39.4	1.40	40.0	1.30	42.1	1.25	44.7	1.05	45.6	0.95
48	39.1	1.15	40.6	1.05	41.2	0.95	43.6	0.90				
( ° )	47 ~ 81.5		47 ~ 81.5		47 ~ 81.5		47 ~ 81.5		49 ~ 81.5		49 ~ 81.5	

Unit:ton

C D	47.5m Boom + 21.0m Jib					
	5 °		25 °		45 °	
E ( ° )	B(m)	M	B(m)	M	B(m)	M
81.5	10.6	2.50	17.4	1.85	22.2	1.00
80	13.2	2.50	19.9	1.85	24.4	1.00
78	15.9	2.50	22.4	1.85	26.6	1.00
75	19.8	2.50	25.9	1.75	29.8	1.00
73	22.4	2.50	28.2	1.65	31.9	1.00
70	26.2	2.50	31.5	1.55	34.9	1.00
68	28.6	2.50	33.6	1.50	36.8	0.98
65	32.0	2.25	36.8	1.45	39.6	0.94
63	34.2	2.10	38.8	1.40	41.4	0.92
60	37.4	1.95	41.7	1.35	43.9	0.90
58	39.4	1.85	43.6	1.30	45.5	0.89
55	42.4	1.70	46.2	1.26	47.8	0.87
53	44.2	1.60	47.9	1.23	49.3	0.86
50	46.6	1.00				
48						
( ° )	49 ~ 81.5		52 ~ 81.5		52 ~ 81.5	

B= Working radius C= Jib length D= Jib offset  
E= Boom angle M= Total rated loads  
= Boom angle range (for the unladen condition)

[JIB]  
Performance D

Unit:ton

C D	47.5m Boom + 9.8m Jib						47.5m Boom + 15.4m Jib					
	5 °		25 °		45 °		5 °		25 °		45 °	
E ( ° )	B (m)	M	B (m)	M	B (m)	M	B (m)	M	B (m)	M	B (m)	M
81.5	8.2	7.00	11.3	6.50	13.2	3.90	9.3	3.80	14.2	3.10	17.6	1.95
80	10.5	7.00	13.5	6.50	15.2	3.90	11.7	3.80	16.5	3.10	19.8	1.95
78	12.7	7.00	15.7	6.50	17.2	3.90	14.2	3.80	18.8	3.10	21.9	1.95
75	16.1	7.00	18.8	6.20	20.1	3.75	17.8	3.80	22.1	2.90	24.9	1.85
73	18.2	7.00	20.7	5.80	22.0	3.65	20.1	3.80	24.2	2.80	26.9	1.80
70	21.3	6.50	23.6	5.25	24.8	3.50	23.6	3.80	27.4	2.65	29.7	1.74
68	23.2	6.00	25.4	4.90	26.6	3.45	25.8	3.70	29.4	2.55	31.6	1.70
65	25.7	4.40	27.9	3.85	29.2	3.35	28.9	3.40	32.3	2.45	34.3	1.64
63	27.3	3.45	29.5	3.05	30.7	2.75	30.8	2.85	34.3	2.35	36.0	1.61
60	29.7	2.30	31.7	2.00	32.9	1.85	33.3	1.90	36.6	1.55	38.4	1.30
58	31.3	1.65	33.2	1.45	34.3	1.30	35.0	1.35	38.2	1.05		
( ° )	57 ~ 81.5		57 ~ 81.5		57 ~ 81.5		57 ~ 81.5		57 ~ 81.5		59 ~ 81.5	

Unit:ton

C D	47.5m Boom + 21.0m Jib					
	5 °		25 °		45 °	
E ( ° )	B (m)	M	B (m)	M	B (m)	M
81.5	10.6	2.50	17.4	1.85	22.2	1.00
80	13.2	2.50	19.9	1.85	24.4	1.00
78	15.9	2.50	22.4	1.85	26.6	1.00
75	19.8	2.50	25.9	1.75	29.8	1.00
73	22.4	2.50	28.2	1.65	31.9	1.00
70	26.2	2.50	31.5	1.55	34.9	1.00
68	28.6	2.50	33.6	1.50	36.8	0.98
65	32.0	2.25	36.8	1.45	39.6	0.94
63	34.2	2.10	38.8	1.40	41.4	0.92
60	37.1	1.55	41.6	1.15		
58						
( ° )	59 ~ 81.5		59 ~ 81.5		62 ~ 81.5	

B= Working radius C= Jib length D= Jib offset  
E= Boom angle M= Total rated loads  
= Boom angle range (for the unladen condition)

[JIB]  
Performance E

Unit:ton

C D	47.5m Boom + 9.8m Jib						47.5m Boom + 15.4m Jib					
	5 °		25 °		45 °		5 °		25 °		45 °	
E ( ° )	B(m)	M	B(m)	M	B(m)	M	B(m)	M	B(m)	M	B(m)	M
81.5	8.2	7.00	11.3	6.50	13.2	3.90	9.3	3.80	14.2	3.10	17.6	1.95
80	10.5	7.00	13.5	6.50	15.2	3.90	11.7	3.80	16.5	3.10	19.8	1.95
78	12.7	7.00	15.7	6.50	17.2	3.90	14.2	3.80	18.8	3.10	21.9	1.95
75	16.1	7.00	18.8	6.20	20.1	3.75	17.8	3.80	22.1	2.90	24.9	1.85
73	18.2	7.00	20.7	5.80	22.0	3.65	20.1	3.80	24.2	2.80	26.9	1.80
70	21.3	6.50	23.6	5.25	24.8	3.50	23.6	3.80	27.4	2.65	29.7	1.74
68	23.1	5.50	25.4	4.75	26.6	3.45	25.8	3.70	29.4	2.55	31.6	1.70
65	25.6	3.85	27.8	3.40	29.1	3.10	28.9	3.25	32.3	2.45	34.3	1.64
63	27.2	3.00	29.3	2.60	30.6	2.40	30.6	2.50	34.1	2.05	36.0	1.61
60	29.6	1.90	31.6	1.65	32.8	1.50	33.2	1.55	36.5	1.25	38.3	1.05
58	31.1	1.30	33.1	1.15	34.2	1.00	34.8	1.05				
( ° )	57 ~ 81.5		57 ~ 81.5		57 ~ 81.5		57 ~ 81.5		59 ~ 81.5		59 ~ 81.5	

Unit:ton

C D	47.5m Boom + 21.0m Jib					
	5 °		25 °		45 °	
E ( ° )	B(m)	M	B(m)	M	B(m)	M
81.5	10.6	2.50	17.4	1.85	22.2	1.00
80	13.2	2.50	19.9	1.85	24.4	1.00
78	15.9	2.50	22.4	1.85	26.6	1.00
75	19.8	2.50	25.9	1.75	29.8	1.00
73	22.4	2.50	28.2	1.65	31.9	1.00
70	26.2	2.50	31.5	1.55	34.9	1.00
68	28.6	2.50	33.6	1.50	36.8	0.98
65	32.0	2.25	36.8	1.45	39.6	0.94
63	34.2	2.10	38.8	1.40	41.4	0.92
60	36.9	1.25				
58						
( ° )	59 ~ 81.5		62 ~ 81.5		62 ~ 81.5	

B= Working radius C= Jib length D= Jib offset  
 E= Boom angle M= Total rated loads  
 = Boom angle range (for the unladen condition)



[JIB]  
Performance F

Unit:ton

C D	47.5m Boom + 9.8m Jib						47.5m Boom + 15.4m Jib					
	5 °		25 °		45 °		5 °		25 °		45 °	
E ( ° )	B (m)	M	B (m)	M	B (m)	M	B (m)	M	B (m)	M	B (m)	M
81.5	8.2	7.00	11.3	6.50	13.2	3.90	9.3	3.80	14.2	3.10	17.6	1.95
80	10.5	7.00	13.5	6.50	15.2	3.90	11.7	3.80	16.5	3.10	19.8	1.95
78	12.7	7.00	15.7	6.50	17.2	3.90	14.2	3.80	18.8	3.10	21.9	1.95
75	16.1	7.00	18.8	6.20	20.1	3.75	17.8	3.80	22.1	2.90	24.9	1.85
73	18.1	6.25	20.6	5.20	22.0	3.65	20.1	3.80	24.2	2.80	26.9	1.80
70	20.6	4.05	23.0	3.40	24.7	3.00	23.4	3.35	27.4	2.60	29.7	1.74
68	22.3	2.95	24.7	2.45	26.2	2.20	25.2	2.40	29.1	1.85		
( ° )	67 ~ 81.5		67 ~ 81.5		67 ~ 81.5		67 ~ 81.5		67 ~ 81.5		69 ~ 81.5	

Unit:ton

C D	47.5m Boom + 21.0m Jib					
	5 °		25 °		45 °	
E ( ° )	B (m)	M	B (m)	M	B (m)	M
81.5	10.6	2.50	17.4	1.85	22.2	1.00
80	13.2	2.50	19.9	1.85	24.4	1.00
78	15.9	2.50	22.4	1.85	26.6	1.00
75	19.8	2.50	25.9	1.75	29.8	1.00
73	22.4	2.50	28.2	1.65	31.9	1.00
70	26.2	2.50	31.5	1.55	34.9	1.00
68	28.3	1.95				
( ° )	67 ~ 81.5		69 ~ 81.5		69 ~ 81.5	

B= Working radius C= Jib length D= Jib offset  
E= Boom angle M= Total rated loads  
= Boom angle range (for the unladen condition)

**WORKING RADIUS - LIFTING HEIGHT (BOOM, JIB)**

Performance A  
 With 22t counterweight  
 Outriggers fully extended

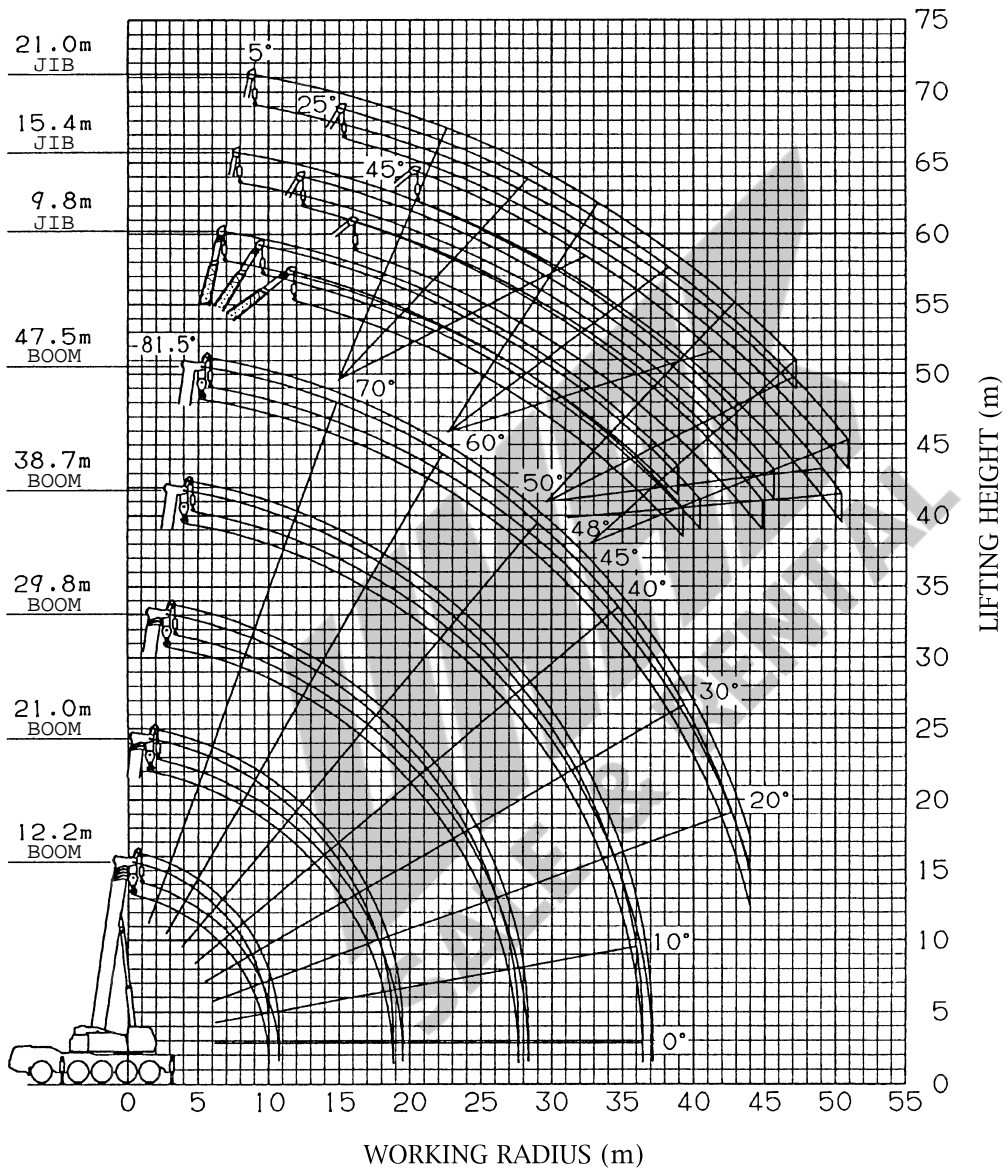

**NOTES:**

1. The deflection of the boom is not incorporated in the figure above.
2. The above figure is for the boom "telescoping method I".

**DIMENSIONS** (1/100)

[On public thoroughfare traveling condition]

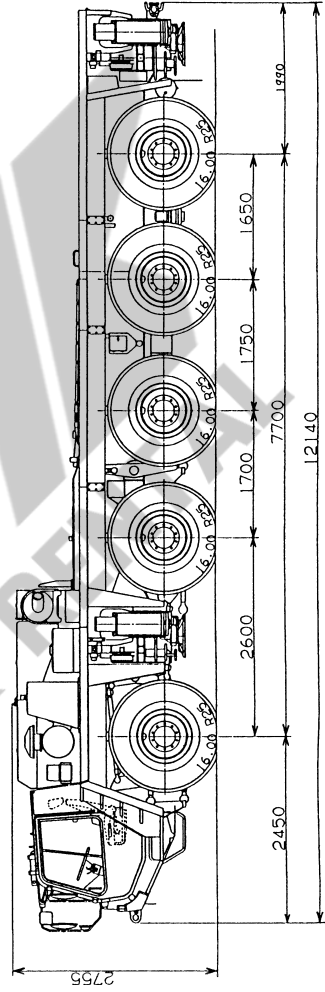
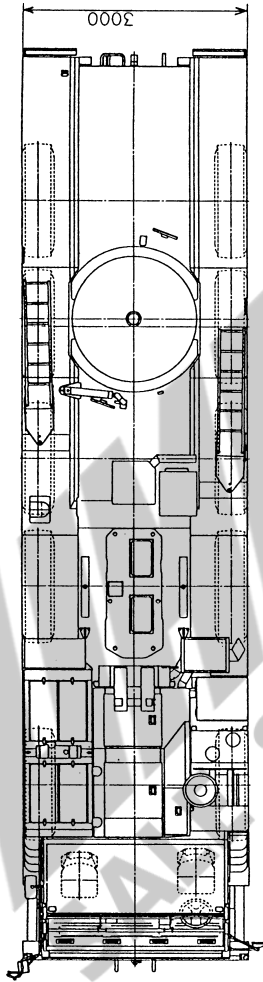

**DIMENSIONS** (1/100)

[On-site traveling condition]

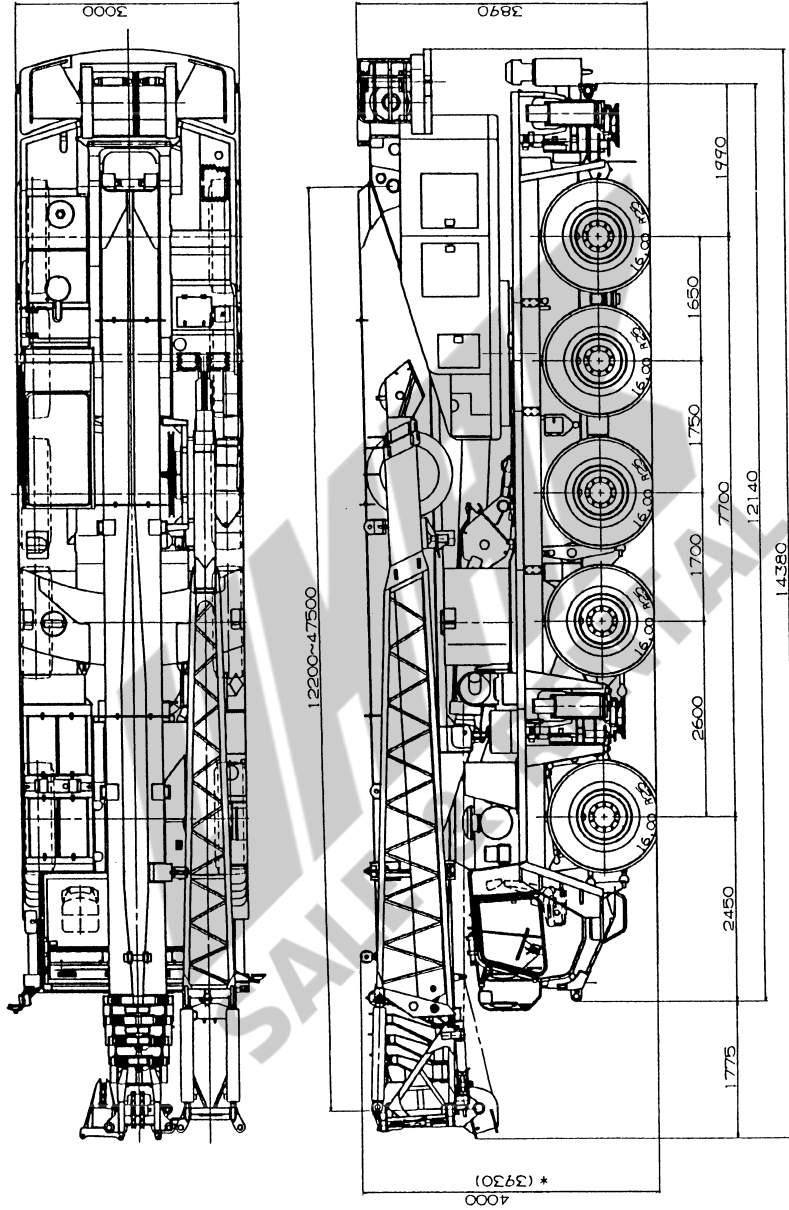

\*-marked dimension: when the guide sheave is removed from the top surface of the base boom section.

<b>TOTAL RATED LOADS</b>
--------------------------

1. The total rated loads shown are for the case where the outriggers are set horizontally on firm level ground. The values above the bold lines are based on the crane strength while those below are based on the crane stability.
2. The weights of the slings and hooks (50t hook: 600kg, 8t hook: 250kg) are included in the total rated loads shown.
3. The total rated load is based on the actual working radius including the deflection of the boom.
4. The table below shows the classification of Performances LA to LC of the total rated load.

Counterweight Outrigger extension width	22t	12t
8.0m	LA	LB
7.0m	LB	LC
5.3m	–	–
4.6m	–	–

5. The standard hook and number of part lines are shown in the total rated loads chart. The load per line should not exceed 8.0t.
6. The elevation wire rope is a 4-part line.
7. When the maximum instantaneous velocity is 10m/s or more, stop crane operation.
8. Mark in the total rated load chart shows the boom angle range (under no load)
9. The jib should be operated with the boom "telescoping method I".

## Performance LA 1.6m + 11m luffing jib

Unit: ton

16.6m boom					
B (m)	Offset				
	10°	20°	30°	45°	60°
6.0	30.0				
7.0	30.0				
8.0	28.0	24.8			
9.0	27.5	24.4			
10.0	27.0	24.1	21.4		
11.0	26.6	23.8	21.2	17.7	
12.0	25.7	23.5	21.0	17.6	
14.0	23.5	22.3	20.8	17.5	14.3
16.0	19.7	20.3	19.9	17.5	13.9
18.0	16.6	17.1	17.5	17.2	
20.0	14.1	14.5	14.8	15.1	
22.0	12.0	12.3	12.5		
24.0	10.2	10.4	10.5		
26.0	7.9				
(°)	16~ 81.5	32~ 81.5	34~ 81.5	53~ 81.5	68~ 81.5
F	50t hook (600kg)				
H	4part-line				

Unit: ton

21.0m boom					
B (m)	Offset				
	10°	20°	30°	45°	60°
7.0	30.0				
8.0	30.0				
9.0	29.3	25.7			
10.0	28.7	25.5	22.6		
11.0	26.9	25.3	22.4		
12.0	25.4	24.6	22.3	18.5	
14.0	22.8	22.2	21.7	18.5	15.0
16.0	19.0	19.8	19.9	18.5	14.6
18.0	15.9	16.5	17.1	17.7	14.3
20.0	13.4	13.9	14.4	14.8	
22.0	11.3	11.8	12.1	12.5	
24.0	9.6	9.9	10.2		
26.0	8.1	8.4	8.6		
28.0	6.9	7.0			
30.0	5.6				
(°)	18~ 81.5	31~ 81.5	40~ 81.5	55~ 81.5	67~ 81.5
F	50t hook (600kg)				
H	4part-line				

Unit: ton

29.8m boom					
B (m)	Offset				
	10°	20°	30°	45°	60°
9.0	19.2				
10.0	19.2				
11.0	19.2	19.2			
12.0	19.2	19.2	17.0		
14.0	19.2	19.2	17.0	13.9	
16.0	17.5	17.9	17.0	13.9	11.5
18.0	15.0	15.6	16.0	13.9	11.5
20.0	12.5	13.1	13.7	13.9	11.5
22.0	10.4	11.0	11.5	12.1	11.5
24.0	8.7	9.2	9.6	10.1	
26.0	7.2	7.7	8.0	8.4	
28.0	6.0	6.3	6.6	6.9	
30.0	4.8	5.1	5.4		
32.0	3.8	4.0	4.2		
34.0	2.8	3.0	3.2		
36.0	2.0	2.2			
38.0	1.3				
(°)	20~ 81.5	30~ 81.5	37~ 81.5	53~ 81.5	66~ 81.5
F	50t hook (600kg)				
H	3part-line				

B= Working radius F= Standard hook H= No. of part-line

## Performance LA 1.6m + 19m luffing jib

Unit: ton

16.6m boom					
B (m)	Offset				
	10°	20°	30°	45°	60°
9.0	22.4				
10.0	21.8				
11.0	21.2				
12.0	20.7	18.4			
14.0	19.0	17.6			
16.0	17.4	16.8	15.2		
18.0	16.0	15.6	14.5	11.3	
20.0	14.8	14.6	13.5	10.7	8.2
22.0	13.5	13.8	12.6	10.1	7.9
24.0	11.8	12.3	11.8	9.7	7.7
26.0	10.3	10.7	11.1	9.3	
28.0	9.0	9.3	9.6	9.1	
30.0	7.8	8.1	8.3		
32.0	6.8	7.0	7.2		
34.0	5.3				
(°)	16~ 81.5	32~ 81.5	34~ 81.5	53~ 81.5	68~ 81.5
F	50t hook (600kg)				
H	3part-line				

Unit: ton

21.0m boom					
B (m)	Offset				
	10°	20°	30°	45°	60°
10.0	18.5				
11.0	18.5				
12.0	18.5				
14.0	17.6	17.2			
16.0	15.9	15.5	15.2		
18.0	14.4	14.2	14.0		
20.0	13.2	13.0	12.9	11.2	
22.0	12.2	12.1	12.0	10.7	8.3
24.0	11.1	11.2	11.2	10.3	8.1
26.0	9.6	10.2	10.5	9.9	7.9
28.0	8.3	8.8	9.2	9.6	
30.0	7.2	7.6	7.9	8.3	
32.0	6.2	6.5	6.8		
34.0	5.3	5.6	5.8		
36.0	4.5	4.7			
38.0	3.7				
(°)	18~ 81.5	31~ 81.5	40~ 81.5	55~ 81.5	67~ 81.5
F	50t hook (600kg)				
H	3part-line				

Unit: ton

29.8m boom					
B (m)	Offset				
	10°	20°	30°	45°	60°
12.0	12.4				
14.0	12.4				
16.0	12.4	12.4			
18.0	12.4	12.4	12.2		
20.0	11.9	11.7	11.6		
22.0	10.9	10.8	10.7	9.9	
24.0	10.0	10.0	10.0	9.9	7.9
26.0	8.5	9.3	9.3	9.4	7.9
28.0	7.3	7.9	8.6	8.9	7.9
30.0	6.1	6.8	7.3	7.9	7.9
32.0	5.2	5.7	6.2	6.8	
34.0	4.2	4.8	5.2	5.7	
36.0	3.4	3.8	4.2	4.6	
38.0	2.6	3.0	3.4		
40.0	2.0	2.3	2.5		
42.0	1.4	1.6	1.8		
44.0		1.0			
(°)	32~ 81.5	29~ 81.5	37~ 81.5	53~ 81.5	66~ 81.5
F	50t hook (600kg)				
H	2part-line				

B= Working radius F= Standard hook H= No. of part-line

## Performance LA 1.6m + 19m luffing jib

Unit: ton

38.7m boom					
B (m)	Offset				
	10°	20°	30°	45°	60°
18.0	7.1	7.1			
20.0	7.1	7.1	6.3		
22.0	7.1	7.0	6.2		
24.0	7.1	6.8	6.1	5.2	
26.0	7.1	6.7	6.1	5.1	4.3
28.0	6.9	6.6	6.0	5.1	4.3
30.0	6.2	6.5	6.0	5.1	4.3
32.0	5.4	5.8	5.9	5.1	4.3
34.0	4.5	5.1	5.5	5.1	4.3
36.0	3.7	4.2	4.7	5.1	
38.0	3.0	3.4	3.8	4.3	
40.0	2.3	2.7	3.1	3.4	
42.0	1.7	2.1	2.4	2.7	
44.0	1.1	1.5	1.7		
46.0			1.1		
(°)	43~ 81.5	45~ 81.5	44~ 81.5	52~ 81.5	66~ 81.5
F	8t hook (250kg)				
H	1part-line				

Unit: ton

43.0m boom					
B (m)	Offset				
	10°	20°	30°	45°	60°
22.0	5.6	5.6	5.6		
24.0	5.6	5.6	5.6	5.6	
26.0	5.6	5.6	5.6	5.6	4.6
28.0	5.6	5.6	5.6	5.6	4.6
30.0	5.5	5.6	5.6	5.6	4.6
32.0	4.9	5.1	5.3	5.4	4.6
34.0	4.5	4.6	4.8	5.0	4.6
36.0	3.7	4.2	4.4	4.6	4.6
38.0	3.0	3.5	3.9	4.1	
40.0	2.3	2.8	3.2	3.6	
42.0	1.7	2.1	2.5	2.8	
44.0	1.2	1.6	1.9	2.1	
46.0			1.3	1.5	
(°)	47~ 81.5	49~ 81.5	48~ 81.5	50~ 81.5	65~ 81.5
F	8t hook (250kg)				
H	1part-line				

B= Working radius F= Standard hook H= No. of part-line



## Performance LA 1.6m + 27m luffing jib

Unit: ton

16.6m boom					
B (m)	Offset				
	10°	20°	30°	45°	60°
12.0	16.0				
14.0	15.3				
16.0	14.0	13.9			
18.0	12.9	12.8			
20.0	11.9	11.8	10.6		
22.0	11.1	11.0	10.0		
24.0	10.3	10.3	9.4		
26.0	9.7	9.6	8.9	7.2	
28.0	9.1	9.1	8.4	6.8	5.2
30.0	8.5	8.6	8.0	6.5	5.1
32.0	7.7	8.1	7.6	6.3	4.9
34.0	6.8	7.2	7.2	6.0	
36.0	6.0	6.3	6.6	5.9	
38.0	5.4	5.6	5.8		
40.0	4.7	4.9	5.0		
42.0	3.6				
(°)	16~ 81.5	31~ 81.5	34~ 81.5	52~ 81.5	67~ 81.5
F	50t hook (600kg)				
H	2 part-line				

Unit: ton

21.0m boom					
B (m)	Offset				
	10°	20°	30°	45°	60°
12.0	11.7				
14.0	11.7				
16.0	11.7				
18.0	11.5	11.3			
20.0	10.4	10.3			
22.0	9.6	9.5	9.5		
24.0	8.8	8.8	8.8		
26.0	8.2	8.1	8.2	7.6	
28.0	7.6	7.6	7.7	7.2	
30.0	7.1	7.1	7.2	6.9	5.3
32.0	6.6	6.7	6.8	6.6	5.2
34.0	6.2	6.3	6.4	6.4	5.1
36.0	5.4	5.9	6.1	6.2	
38.0	4.7	5.1	5.5	5.8	
40.0	4.0	4.4	4.7		
42.0	3.4	3.7	3.9		
44.0	2.8	3.0			
46.0	2.3				
(°)	18~ 81.5	30~ 81.5	40~ 81.5	54~ 81.5	67~ 81.5
F	50t hook (600kg)				
H	2part-line				

Unit: ton

29.8m boom					
B (m)	Offset				
	10°	20°	30°	45°	60°
16.0	8.0				
18.0	8.0				
20.0	8.0	8.0			
22.0	8.0	8.0			
24.0	7.7	7.7	7.7		
26.0	7.1	7.1	7.2		
28.0	6.6	6.6	6.7	6.9	
30.0	6.1	6.2	6.4	6.5	
32.0	5.7	5.8	6.0	6.1	6.0
34.0	5.2	5.4	5.5	5.8	5.9
36.0	4.4	5.1	5.2	5.5	5.7
38.0	3.7	4.3	4.9	5.2	5.5
40.0	3.0	3.6	4.1	4.7	
42.0	2.4	2.9	3.3	3.9	
44.0	1.8	2.3	2.7	3.1	
46.0	1.3	1.7	2.0		
48.0		1.1	1.4		
(°)	40~ 81.5	39~ 81.5	42~ 81.5	53~ 81.5	66~ 81.5
F	8t hook (250kg)				
H	1part-line				

B= Working radius F= Standard hook H= No. of part-line

## Performance LA 1.6m + 27m luffing jib

Unit: ton

38.7m boom					
B (m)	Offset				
	10°	20°	30°	45°	60°
18.0	4.8				
20.0	4.8				
22.0	4.8	4.8			
24.0	4.8	4.8			
26.0	4.8	4.8	4.7		
28.0	4.8	4.8	4.6		
30.0	4.8	4.8	4.6	3.9	
32.0	4.7	4.7	4.5	3.8	
34.0	4.4	4.4	4.5	3.8	3.2
36.0	4.1	4.2	4.3	3.8	3.2
38.0	3.6	3.9	4.1	3.8	3.2
40.0	2.9	3.6	3.9	3.8	3.2
42.0	2.3	2.9	3.4	3.8	3.2
44.0	1.8	2.3	2.8	3.4	
46.0	1.3	1.8	2.2	2.7	
48.0		1.2	1.6	2.1	
50.0			1.1	1.5	
(°)	49~ 81.5	50~ 81.5	50~ 81.5	52~ 81.5	66~ 81.5
F	8t hook (250kg)				
H	1part-line				

Unit: ton

43.0m boom					
B (m)	Offset				
	10°	20°	30°	45°	60°
18.0	3.8				
20.0	3.8				
22.0	3.8	3.8			
24.0	3.8	3.8			
26.0	3.8	3.8	3.8		
28.0	3.8	3.8	3.8		
30.0	3.8	3.8	3.8	3.8	
32.0	3.8	3.8	3.8	3.8	
34.0	3.8	3.8	3.8	3.8	3.4
36.0	3.8	3.8	3.8	3.8	3.4
38.0	3.5	3.7	3.8	3.8	3.4
40.0	2.9	3.4	3.6	3.6	3.4
42.0	2.3	2.9	3.2	3.4	3.4
44.0	1.7	2.3	2.8	3.2	3.2
46.0	1.2	1.7	2.2	2.8	
48.0		1.2	1.7	2.2	
50.0			1.2	1.6	
52.0				1.0	
(°)	52~ 81.5	53~ 81.5	53~ 81.5	53~ 81.5	65~ 81.5
F	8t hook (250kg)				
H	1part-line				

B= Working radius F= Standard hook H= No. of part-line

## Performance LA 1.6m + 35m luffing jib

Unit: ton

16.6m boom					
B (m)	Offset				
	10°	20°	30°	45°	60°
14.0	9.5				
16.0	9.5				
18.0	9.5				
20.0	9.5	9.1			
22.0	9.0	8.5			
24.0	8.4	8.0			
26.0	7.8	7.5	7.0		
28.0	7.3	7.1	6.6		
30.0	6.9	6.7	6.2		
32.0	6.5	6.3	5.9	4.8	
34.0	6.1	5.9	5.5	4.6	
36.0	5.8	5.6	5.2	4.4	3.3
38.0	5.5	5.2	4.9	4.2	3.2
40.0	5.2	4.9	4.7	4.0	3.1
42.0	4.6	4.7	4.5	3.9	
44.0	4.1	4.4	4.3	3.8	
46.0	3.6	3.8	4.1		
48.0	3.1	3.3	3.5		
50.0	2.3				
(°)	16~ 81.5	31~ 81.5	34~ 81.5	52~ 81.5	67~ 81.5
F	50t hook (600kg)				
H	2part-line				

Unit: ton

21.0m boom					
B (m)	Offset				
	10°	20°	30°	45°	60°
16.0	7.6				
18.0	7.6				
20.0	7.6				
22.0	7.6	7.6			
24.0	7.0	7.0			
26.0	6.4	6.4	6.5		
28.0	5.9	6.0	6.1		
30.0	5.5	5.6	5.7		
32.0	5.1	5.2	5.3	5.3	
34.0	4.8	4.9	5.0	5.1	
36.0	4.5	4.6	4.7	4.8	3.8
38.0	4.2	4.3	4.4	4.6	3.6
40.0	4.0	4.0	4.2	4.4	3.5
42.0	3.8	3.8	3.9	4.2	3.5
44.0	3.5	3.6	3.7	4.0	
46.0	3.0	3.4	3.6	3.8	
48.0	2.5	2.9	3.2	3.5	
50.0	2.1	2.4	2.6		
52.0	1.6	1.9			
53.9	1.2				
(°)	18~ 81.5	31~ 81.5	40~ 81.5	49~ 81.5	67~ 81.5
F	8t hook (250kg)				
H	1part-line				

Unit: ton

29.8m boom					
B (m)	Offset				
	10°	20°	30°	45°	60°
18.0	5.4				
20.0	5.4				
22.0	5.4				
24.0	5.4	5.4			
26.0	5.4	5.4			
28.0	5.3	5.3	5.4		
30.0	4.8	4.9	5.0		
32.0	4.5	4.6	4.7		
34.0	4.2	4.3	4.4	4.6	
36.0	3.9	4.0	4.1	4.4	
38.0	3.6	3.7	3.8	4.1	4.0
40.0	3.4	3.5	3.6	3.9	3.9
42.0	2.9	3.3	3.4	3.7	3.8
44.0	2.4	3.0	3.2	3.5	3.7
46.0	1.8	2.4	3.0	3.3	3.6
48.0	1.4	1.9	2.4	3.1	
50.0		1.4	1.9	2.4	
52.0		1.0	1.4	1.8	
(°)	47~ 81.5	46~ 81.5	49~ 81.5	53~ 81.5	66~ 81.5
F	8t hook (250kg)				
H	1part-line				

B= Working radius F= Standard hook H= No. of part-line

## Performance LA 1.6m + 35m luffing jib

Unit: ton

38.7m boom					
B (m)	Offset				
	10°	20°	30°	45°	60°
20.0	3.3				
22.0	3.3				
24.0	3.3				
26.0	3.3	3.3			
28.0	3.3	3.3			
30.0	3.3	3.3	3.3		
32.0	3.3	3.3	3.3		
34.0	3.1	3.2	3.3		
36.0	2.9	3.0	3.1	3.0	
38.0	2.7	2.8	2.9	3.0	
40.0	2.5	2.6	2.7	3.0	2.5
42.0	2.4	2.4	2.6	2.9	2.5
44.0	2.2	2.3	2.4	2.7	2.5
46.0	1.7	2.2	2.3	2.6	2.5
48.0	1.2	1.8	2.2	2.5	2.5
50.0		1.4	1.9	2.3	2.5
52.0			1.4	2.0	
54.0				1.5	
(°)	53~ 81.5	55~ 81.5	54~ 81.5	58~ 81.5	66~ 81.5
F	8t hook (250kg)				
H	1part-line				

Unit: ton

43.0m boom					
B (m)	Offset				
	10°	20°	30°	45°	60°
20.0	2.5				
22.0	2.5				
24.0	2.5				
26.0	2.5	2.5			
28.0	2.5	2.5			
30.0	2.5	2.5			
32.0	2.5	2.5	2.5		
34.0	2.5	2.5	2.5		
36.0	2.5	2.5	2.5		
38.0	2.5	2.5	2.5	2.5	
40.0	2.5	2.5	2.5	2.5	
42.0	2.3	2.4	2.5	2.5	2.5
44.0	2.1	2.2	2.4	2.5	2.5
46.0	1.6	2.1	2.2	2.5	2.5
48.0		1.8	2.1	2.4	2.4
50.0		1.3	1.9	2.2	2.2
52.0			1.4	2.0	2.1
54.0				1.5	
(°)	58~ 81.5	58~ 81.5	57~ 81.5	61~ 81.5	65~ 81.5
F	8t hook (250kg)				
H	1part-line				

B= Working radius F= Standard hook H= No. of part-line

## Performance LB 1.6m + 11m luffing jib

Unit: ton

16.6m boom					
B (m)	Offset				
	10°	20°	30°	45°	60°
6.0	29.2				
7.0	28.5				
8.0	28.0	24.8			
9.0	27.5	24.4			
10.0	27.0	24.1	21.4		
11.0	26.6	23.8	21.2	17.7	
12.0	25.7	23.5	21.0	17.6	
14.0	21.5	22.3	20.8	17.5	14.3
16.0	17.3	17.9	18.5	17.5	13.9
18.0	14.1	14.5	15.0	15.5	
20.0	11.6	12.0	12.3	12.6	
22.0	9.6	9.9	10.1		
24.0	8.0	8.2	8.3		
26.0	6.7				
(°)	16~ 81.5	32~ 81.5	34~ 81.5	53~ 81.5	68~ 81.5
F	50t hook (600kg)				
H	4part-line				

Unit: ton

21.0m boom					
B (m)	Offset				
	10°	20°	30°	45°	60°
7.0	30.0				
8.0	29.7				
9.0	29.3	25.7			
10.0	28.7	25.5	22.6		
11.0	26.9	25.3	22.4		
12.0	25.4	24.6	22.3	18.5	
14.0	20.9	21.7	21.7	18.5	15.0
16.0	16.7	17.4	18.0	18.5	14.6
18.0	13.4	14.0	14.5	15.2	14.3
20.0	11.0	11.5	11.9	12.3	
22.0	9.0	9.4	9.7	10.1	
24.0	7.5	7.8	8.0		
26.0	6.1	6.4	6.5		
28.0	4.8	5.0			
30.0	3.7				
(°)	18~ 81.5	31~ 81.5	40~ 81.5	55~ 81.5	67~ 81.5
F	50t hook (600kg)				
H	4part-line				

Unit: ton

29.8m boom					
B (m)	Offset				
	10°	20°	30°	45°	60°
9.0	19.2				
10.0	19.2				
11.0	19.2	19.2			
12.0	19.2	19.2	17.0		
14.0	19.2	19.2	17.0	13.9	
16.0	15.7	16.6	17.0	13.9	11.5
18.0	12.6	13.3	13.9	13.9	11.5
20.0	10.1	10.7	11.3	11.9	11.5
22.0	8.2	8.7	9.2	9.7	10.0
24.0	6.5	7.1	7.4	7.9	
26.0	5.1	5.5	5.9	6.3	
28.0	3.8	4.2	4.6	4.9	
30.0	2.8	3.1	3.4		
32.0	1.9	2.1	2.3		
34.0	1.1	1.3	1.4		
(°)	34~ 81.5	36~ 81.5	37~ 81.5	53~ 81.5	66~ 81.5
F	50t hook (600kg)				
H	3part-line				

B= Working radius F= Standard hook H= No. of part-line

## Performance LB 1.6m + 19m luffing jib

Unit: ton

16.6m boom						
B (m)	Offset					60°
	10°	20°	30°	45°	60°	
9.0	22.4					
10.0	21.8					
11.0	21.2					
12.0	20.7	18.4				
14.0	19.0	17.6				
16.0	17.4	16.8	15.2			
18.0	15.7	15.6	14.5	11.3		
20.0	13.1	13.9	13.5	10.7	8.2	
22.0	11.1	11.7	12.3	10.1	7.9	
24.0	9.5	10.0	10.5	9.7	7.7	
26.0	8.1	8.5	8.9	9.3		
28.0	7.0	7.3	7.6	8.0		
30.0	6.0	6.3	6.5			
32.0	5.1	5.3	5.4			
34.0	4.3					
(°)	16~ 81.5	32~ 81.5	34~ 81.5	53~ 81.5	68~ 81.5	
F	50t hook (600kg)					
H	3part-line					

Unit: ton

21.0m boom						
B (m)	Offset					60°
	10°	20°	30°	45°	60°	
10.0	18.5					
11.0	18.5					
12.0	18.5					
14.0	17.6	17.2				
16.0	15.9	15.5	15.2			
18.0	14.4	14.2	14.0			
20.0	12.5	13.0	12.9	11.2		
22.0	10.5	11.2	11.9	10.7	8.3	
24.0	8.8	9.5	10.0	10.3	8.1	
26.0	7.5	8.0	8.5	9.1	7.9	
28.0	6.4	6.8	7.2	7.7		
30.0	5.4	5.8	6.1	6.5		
32.0	4.4	4.8	5.1			
34.0	3.6	3.9	4.1			
36.0	2.8	3.0				
38.0	2.1					
(°)	18~ 81.5	31~ 81.5	40~ 81.5	55~ 81.5	67~ 81.5	
F	50t hook (600kg)					
H	3part-line					

Unit: ton

29.8m boom						
B (m)	Offset					60°
	10°	20°	30°	45°	60°	
12.0	12.4					
14.0	12.4					
16.0	12.4	12.4				
18.0	12.4	12.4	12.2			
20.0	11.5	11.7	11.6			
22.0	9.5	10.4	10.7	9.9		
24.0	7.9	8.7	9.4	9.9	7.9	
26.0	6.6	7.3	7.9	8.7	7.9	
28.0	5.3	6.1	6.6	7.3	7.8	
30.0	4.2	4.9	5.5	6.1	6.5	
32.0	3.3	3.9	4.4	5.0		
34.0	2.5	3.0	3.4	3.9		
36.0	1.7	2.2	2.6	3.0		
38.0	1.1	1.5	1.8			
40.0			1.1			
(°)	41~ 81.5	44~ 81.5	42~ 81.5	53~ 81.5	66~ 81.5	
F	50t hook (600kg)					
H	2part-line					

B= Working radius F= Standard hook H= No. of part-line

## Performance LB 1.6m + 19m luffing jib

Unit: ton

38.7m boom					
B (m)	Offset				
	10 °	20 °	30 °	45 °	60 °
18.0	7.1	7.1			
20.0	7.1	7.1	6.3		
22.0	7.1	7.0	6.2		
24.0	7.1	6.8	6.1	5.2	
26.0	6.8	6.7	6.1	5.1	4.3
28.0	5.6	6.4	6.0	5.1	4.3
30.0	4.5	5.3	5.9	5.1	4.3
32.0	3.6	4.2	4.8	5.1	4.3
34.0	2.8	3.4	3.9	4.5	4.3
36.0	2.0	2.6	3.0	3.6	
38.0	1.4	1.9	2.3	2.7	
40.0			1.6	2.0	
( ° )	51 ~ 81.5	54 ~ 81.5	53 ~ 81.5	55 ~ 81.5	66 ~ 81.5
F	8t hook (250kg)				
H	1part-line				

Unit: ton

43.0m boom					
B (m)	Offset				
	10 °	20 °	30 °	45 °	60 °
22.0	5.6	5.6	5.6		
24.0	5.6	5.6	5.6	5.6	
26.0	5.6	5.6	5.6	5.6	4.6
28.0	5.6	5.6	5.6	5.6	4.6
30.0	4.6	5.3	5.6	5.6	4.6
32.0	3.6	4.3	4.9	5.4	4.6
34.0	2.8	3.4	3.9	4.6	4.6
36.0	2.1	2.6	3.1	3.7	4.0
38.0		1.9	2.4	2.9	
40.0			1.7	2.1	
42.0				1.4	
( ° )	57 ~ 81.5	57 ~ 81.5	57 ~ 81.5	56 ~ 81.5	65 ~ 81.5
F	8t hook (250kg)				
H	1part-line				

B= Working radius F= Standard hook H= No. of part-line

## Performance LB 1.6m + 27m luffing jib

Unit: ton

16.6m boom					
B (m)	Offset				
	10°	20°	30°	45°	60°
12.0	16.0				
14.0	15.3				
16.0	14.0	13.9			
18.0	12.9	12.8			
20.0	11.9	11.8	10.6		
22.0	11.1	11.0	10.0		
24.0	10.3	10.3	9.4		
26.0	9.0	9.6	8.9	7.2	
28.0	7.8	8.4	8.4	6.8	5.2
30.0	6.8	7.3	7.8	6.5	5.1
32.0	5.9	6.4	6.8	6.3	4.9
34.0	5.2	5.6	5.9	6.0	
36.0	4.5	4.8	5.1	5.5	
38.0	3.9	4.2	4.4		
40.0	3.3	3.5	3.6		
42.0	2.7				
(°)	16~ 81.5	31~ 81.5	34~ 81.5	52~ 81.5	67~ 81.5
F	50t hook (600kg)				
H	2part-line				

Unit: ton

21.0m boom					
B (m)	Offset				
	10°	20°	30°	45°	60°
12.0	11.7				
14.0	11.7				
16.0	11.7				
18.0	11.5	11.3			
20.0	10.4	10.3			
22.0	9.6	9.5	9.5		
24.0	8.8	8.8	8.8		
26.0	8.2	8.1	8.2	7.6	
28.0	7.2	7.6	7.7	7.2	
30.0	6.2	6.8	7.2	6.9	5.3
32.0	5.4	5.9	6.4	6.6	5.2
34.0	4.6	5.1	5.5	6.1	5.1
36.0	3.8	4.3	4.7	5.2	
38.0	3.2	3.6	4.0	4.4	
40.0	2.5	2.9	3.2		
42.0	2.0	2.3	2.5		
44.0	1.5	1.7			
46.0	1.0				
(°)	18~ 81.5	30~ 81.5	40~ 81.5	54~ 81.5	67~ 81.5
F	50t hook (600kg)				
H	2part-line				

Unit: ton

29.8m boom					
B (m)	Offset				
	10°	20°	30°	45°	60°
16.0	8.0				
18.0	8.0				
20.0	8.0	8.0			
22.0	8.0	8.0			
24.0	7.7	7.7	7.7		
26.0	7.1	7.1	7.2		
28.0	6.4	6.6	6.7	6.9	
30.0	5.4	6.2	6.4	6.5	
32.0	4.4	5.2	6.0	6.1	6.0
34.0	3.5	4.3	5.0	5.8	5.9
36.0	2.8	3.5	4.2	4.9	5.4
38.0	2.1	2.7	3.3	4.1	4.5
40.0	1.5	2.1	2.6	3.2	
42.0	1.0	1.5	1.9	2.5	
44.0			1.3	1.8	
(°)	46~ 81.5	50~ 81.5	50~ 81.5	53~ 81.5	66~ 81.5
F	8t hook (250kg)				
H	1part-line				

B= Working radius F= Standard hook H= No. of part-line



## Performance LB 1.6m + 27m luffing jib

Unit: ton

38.7m boom					
B (m)	Offset				
	10°	20°	30°	45°	60°
18.0	4.8				
20.0	4.8				
22.0	4.8	4.8			
24.0	4.8	4.8			
26.0	4.8	4.8	4.7		
28.0	4.8	4.8	4.6		
30.0	4.8	4.8	4.6	3.9	
32.0	4.3	4.7	4.5	3.8	
34.0	3.5	4.3	4.5	3.8	3.2
36.0	2.7	3.5	4.2	3.8	3.2
38.0	2.0	2.8	3.4	3.8	3.2
40.0	1.5	2.1	2.7	3.4	3.2
42.0		1.5	2.0	2.7	3.1
44.0			1.5	2.0	
46.0				1.4	
(°)	56~ 81.5	57~ 81.5	58~ 81.5	58~ 81.5	66~ 81.5
F	8t hook (250kg)				
H	1part-line				

Unit: ton

43.0m boom					
B (m)	Offset				
	10°	20°	30°	45°	60°
18.0	3.8				
20.0	3.8				
22.0	3.8	3.8			
24.0	3.8	3.8			
26.0	3.8	3.8	3.8		
28.0	3.8	3.8	3.8		
30.0	3.8	3.8	3.8	3.8	
32.0	3.8	3.8	3.8	3.8	
34.0	3.4	3.8	3.8	3.8	3.4
36.0	2.7	3.5	3.8	3.8	3.4
38.0	2.0	2.7	3.4	3.8	3.4
40.0		2.1	2.7	3.5	3.4
42.0			2.1	2.8	3.2
44.0				2.1	2.5
46.0				1.5	
(°)	60~ 81.5	62~ 81.5	62~ 81.5	61~ 81.5	65~ 81.5
F	8t hook (250kg)				
H	1part-line				

B= Working radius F= Standard hook H= No. of part-line

## Performance LB 1.6m + 35m luffing jib

Unit: ton

16.6m boom					
B (m)	Offset				
	10°	20°	30°	45°	60°
14.0	9.5				
16.0	9.5				
18.0	9.5				
20.0	9.5	9.1			
22.0	9.0	8.5			
24.0	8.4	8.0			
26.0	7.8	7.5	7.0		
28.0	7.3	7.1	6.6		
30.0	6.9	6.7	6.2		
32.0	6.4	6.3	5.9	4.8	
34.0	5.6	5.9	5.5	4.6	
36.0	5.0	5.4	5.2	4.4	3.3
38.0	4.4	4.8	4.9	4.2	3.2
40.0	3.8	4.2	4.6	4.0	3.1
42.0	3.3	3.7	4.0	3.9	
44.0	2.8	3.1	3.4	3.8	
46.0	2.3	2.6	2.8		
48.0	1.9	2.1	2.3		
49.9	1.5				
(°)	16~ 81.5	31~ 81.5	34~ 81.5	52~ 81.5	67~ 81.5
F	50t hook (600kg)				
H	2part-line				

Unit: ton

21.0m boom					
B (m)	Offset				
	10°	20°	30°	45°	60°
16.0	7.6				
18.0	7.6				
20.0	7.6				
22.0	7.6	7.6			
24.0	7.0	7.0			
26.0	6.4	6.4	6.5		
28.0	5.9	6.0	6.1		
30.0	5.5	5.6	5.7		
32.0	5.1	5.2	5.3	5.3	
34.0	4.8	4.9	5.0	5.1	
36.0	4.5	4.6	4.7	4.8	3.8
38.0	3.9	4.3	4.4	4.6	3.6
40.0	3.3	3.8	4.2	4.4	3.5
42.0	2.7	3.2	3.7	4.2	3.5
44.0	2.2	2.7	3.1	3.7	
46.0	1.7	2.1	2.5	3.0	
48.0	1.3	1.6	2.0	2.3	
49.9		1.2	1.4		
(°)	36~ 81.5	37~ 81.5	40~ 81.5	49~ 81.5	67~ 81.5
F	8t hook (250kg)				
H	1part-line				

Unit: ton

29.8m boom					
B (m)	Offset				
	10°	20°	30°	45°	60°
18.0	5.4				
20.0	5.4				
22.0	5.4				
24.0	5.4	5.4			
26.0	5.4	5.4			
28.0	5.3	5.3	5.4		
30.0	4.8	4.9	5.0		
32.0	4.5	4.6	4.7		
34.0	4.1	4.3	4.4	4.6	
36.0	3.4	4.0	4.1	4.4	
38.0	2.7	3.5	3.8	4.1	4.0
40.0	2.1	2.9	3.6	3.9	3.9
42.0	1.5	2.2	2.9	3.7	3.8
44.0		1.7	2.3	3.1	3.7
46.0		1.2	1.7	2.5	3.0
48.0			1.2	1.9	
49.9				1.3	
(°)	54~ 81.5	54~ 81.5	55~ 81.5	57~ 81.5	66~ 81.5
F	8t hook (250kg)				
H	1part-line				

B= Working radius F= Standard hook H= No. of part-line

## Performance LB 1.6m + 35m luffing jib

Unit: ton

B (m)	38.7m boom				
	Offset				
	10 °	20 °	30 °	45 °	60 °
20.0	3.3				
22.0	3.3				
24.0	3.3				
26.0	3.3	3.3			
28.0	3.3	3.3			
30.0	3.3	3.3	3.3		
32.0	3.3	3.3	3.3		
34.0	3.1	3.2	3.3		
36.0	2.9	3.0	3.1	3.0	
38.0	2.5	2.8	2.9	3.0	
40.0	1.9	2.6	2.7	3.0	2.5
42.0		2.1	2.6	2.9	2.5
44.0		1.6	2.3	2.7	2.5
46.0			1.7	2.5	2.5
48.0				2.0	2.5
49.9				1.4	1.8
( ° )	61 ~ 81.5	61 ~ 81.5	63 ~ 81.5	63 ~ 81.5	66 ~ 81.5
F	8t hook (250kg)				
H	1part-line				

Unit: ton

B (m)	43.0m boom				
	Offset				
	10 °	20 °	30 °	45 °	60 °
20.0	2.5				
22.0	2.5				
24.0	2.5				
26.0	2.5	2.5			
28.0	2.5	2.5			
30.0	2.5	2.5			
32.0	2.5	2.5	2.5		
34.0	2.5	2.5	2.5		
36.0	2.5	2.5	2.5		
38.0	2.4	2.5	2.5	2.5	
40.0		2.5	2.5	2.5	
42.0		2.1	2.5	2.5	2.5
44.0			2.2	2.5	2.5
46.0				2.5	2.5
48.0				2.0	2.4
50.0					1.9
( ° )	65 ~ 81.5	65 ~ 81.5	67 ~ 81.5	67 ~ 81.5	68 ~ 81.5
F	8t hook (250kg)				
H	1part-line				

B= Working radius F= Standard hook H= No. of part-line

Performance LC 1.6m + 11m luffing jib

Unit: ton

16.6m boom					
B (m)	Offset				
	10 °	20 °	30 °	45 °	60 °
6.0	29.2				
7.0	28.5				
8.0	28.0	24.8			
9.0	27.5	24.4			
10.0	27.0	24.1	21.4		
11.0	26.6	23.8	21.2	17.7	
12.0	25.7	23.5	21.0	17.6	
14.0	20.2	21.0	20.8	17.5	14.3
16.0	15.9	16.5	17.1	17.5	13.9
18.0	12.7	13.2	13.6	14.1	
20.0	10.3	10.7	11.0	11.3	
22.0	8.4	8.7	8.9		
24.0	6.9	7.1	7.2		
26.0	5.6				
( ° )	16 ~ 81.5	32 ~ 81.5	34 ~ 81.5	53 ~ 81.5	68 ~ 81.5
F	50t hook (600kg)				
H	4part-line				

Unit: ton

21.0m boom					
B (m)	Offset				
	10 °	20 °	30 °	45 °	60 °
7.0	30.0				
8.0	29.7				
9.0	29.3	25.7			
10.0	28.7	25.5	22.6		
11.0	26.9	25.3	22.4		
12.0	25.4	24.6	22.3	18.5	
14.0	19.5	20.4	21.3	18.5	15.0
16.0	15.2	15.9	16.6	17.5	14.6
18.0	12.1	12.7	13.2	13.8	14.2
20.0	9.7	10.2	10.6	11.1	
22.0	7.8	8.2	8.5	8.9	
24.0	6.3	6.6	6.9		
26.0	5.0	5.3	5.5		
28.0	3.8	4.0			
30.0	2.7				
( ° )	18 ~ 81.5	31 ~ 81.5	40 ~ 81.5	55 ~ 81.5	67 ~ 81.5
F	50t hook (600kg)				
H	4part-line				

Unit: ton

29.8m boom					
B (m)	Offset				
	10 °	20 °	30 °	45 °	60 °
9.0	19.2				
10.0	19.2				
11.0	19.2	19.2			
12.0	19.2	19.2	17.0		
14.0	18.5	19.2	17.0	13.9	
16.0	14.2	15.1	16.0	13.9	11.5
18.0	11.1	11.9	12.6	13.4	11.5
20.0	8.8	9.4	10.0	10.7	11.1
22.0	7.0	7.5	8.0	8.5	8.8
24.0	5.3	5.9	6.3	6.7	
26.0	3.9	4.4	4.8	5.2	
28.0	2.8	3.2	3.5	3.8	
30.0	1.8	2.1	2.4		
32.0			1.4		
( ° )	44 ~ 81.5	46 ~ 81.5	42 ~ 81.5	53 ~ 81.5	66 ~ 81.5
F	50t hook (600kg)				
H	3part-line				

B= Working radius F= Standard hook H= No. of part-line

## Performance LC 1.6m + 19m luffing jib

Unit: ton

16.6m boom					
B (m)	Offset				
	10°	20°	30°	45°	60°
9.0	22.4				
10.0	21.8				
11.0	21.2				
12.0	20.7	18.4			
14.0	19.0	17.6			
16.0	17.4	16.8	15.2		
18.0	14.4	15.3	14.5	11.3	
20.0	11.9	12.7	13.4	10.7	8.2
22.0	10.0	10.6	11.2	10.1	7.9
24.0	8.4	8.9	9.4	9.7	7.7
26.0	7.1	7.5	8.0	8.4	
28.0	6.0	6.4	6.7	7.0	
30.0	5.1	5.4	5.6		
32.0	4.3	4.5	4.6		
34.0	3.4				
(°)	16~ 81.5	32~ 81.5	34~ 81.5	53~ 81.5	68~ 81.5
F	50t hook (600kg)				
H	3part-line				

Unit: ton

21.0m boom					
B (m)	Offset				
	10°	20°	30°	45°	60°
10.0	18.5				
11.0	18.5				
12.0	18.5				
14.0	17.6	17.2			
16.0	15.9	15.5	15.2		
18.0	13.7	14.2	14.0		
20.0	11.3	12.1	12.9	11.2	
22.0	9.3	10.1	10.8	10.7	8.3
24.0	7.8	8.4	9.0	9.8	8.1
26.0	6.5	7.0	7.5	8.2	7.9
28.0	5.4	5.9	6.3	6.8	
30.0	4.4	4.9	5.2	5.6	
32.0	3.5	3.9	4.2		
34.0	2.7	3.0	3.3		
36.0	2.0	2.2			
38.0	1.4				
(°)	18~ 81.5	31~ 81.5	40~ 81.5	55~ 81.5	67~ 81.5
F	50t hook (600kg)				
H	3part-line				

Unit: ton

29.8m boom					
B (m)	Offset				
	10°	20°	30°	45°	60°
12.0	12.4				
14.0	12.4				
16.0	12.4	12.4			
18.0	12.4	12.4	12.2		
20.0	10.3	11.4	11.6		
22.0	8.4	9.3	10.2	9.9	
24.0	6.8	7.6	8.4	9.4	7.9
26.0	5.5	6.3	6.9	7.8	7.9
28.0	4.3	5.1	5.7	6.4	6.9
30.0	3.3	3.9	4.6	5.2	5.6
32.0	2.4	3.0	3.5	4.1	
34.0	1.6	2.1	2.6	3.1	
36.0		1.4	1.7	2.1	
(°)	48~ 81.5	48~ 81.5	50~ 81.5	53~ 81.5	66~ 81.5
F	50t hook (600kg)				
H	2part-line				

B= Working radius F= Standard hook H= No. of part-line

## Performance LC 1.6m + 19m luffing jib

Unit: ton

38.7m boom					
B (m)	Offset				
	10 °	20 °	30 °	45 °	60 °
18.0	7.1	7.1			
20.0	7.1	7.1	6.3		
22.0	7.1	7.0	6.2		
24.0	7.1	6.8	6.1	5.2	
26.0	5.8	6.6	6.1	5.1	4.3
28.0	4.6	5.4	6.0	5.1	4.3
30.0	3.6	4.3	5.0	5.1	4.3
32.0	2.7	3.3	3.9	4.6	4.3
34.0	1.9	2.5	3.0	3.6	4.0
36.0		1.7	2.2	2.7	
38.0				1.9	
(°)	56~ 81.5	56~ 81.5	59~ 81.5	58~ 81.5	66~ 81.5
F	8t hook (250kg)				
H	1part-line				

Unit: ton

43.0m boom					
B (m)	Offset				
	10 °	20 °	30 °	45 °	60 °
22.0	5.6	5.6	5.6		
24.0	5.6	5.6	5.6	5.6	
26.0	5.6	5.6	5.6	5.6	4.6
28.0	4.6	5.4	5.6	5.6	4.6
30.0	3.6	4.3	5.0	5.6	4.6
32.0	2.7	3.4	4.0	4.7	4.6
34.0	1.9	2.5	3.1	3.7	4.1
36.0			2.3	2.9	3.2
38.0				2.1	
(°)	59~ 81.5	62~ 81.5	62~ 81.5	62~ 81.5	65~ 81.5
F	8t hook (250kg)				
H	1part-line				

B= Working radius F= Standard hook H= No. of part-line

## Performance LC 1.6m + 27m luffing jib

Unit: ton

16.6m boom					
B (m)	Offset				
	10°	20°	30°	45°	60°
12.0	16.0				
14.0	15.3				
16.0	14.0	13.9			
18.0	12.9	12.8			
20.0	11.9	11.8	10.6		
22.0	10.9	11.0	10.0		
24.0	9.3	10.1	9.4		
26.0	8.0	8.7	8.9	7.2	
28.0	6.9	7.5	8.0	6.8	5.2
30.0	5.9	6.4	6.9	6.5	5.1
32.0	5.1	5.6	6.0	6.3	4.9
34.0	4.4	4.8	5.1	5.6	
36.0	3.8	4.1	4.4	4.7	
38.0	3.1	3.4	3.7		
40.0	2.5	2.8	2.9		
42.0	2.0				
(°)	16~ 81.5	31~ 81.5	34~ 81.5	52~ 81.5	67~ 81.5
F	50t hook (600kg)				
H	2part-line				

Unit: ton

21.0m boom					
B (m)	Offset				
	10°	20°	30°	45°	60°
12.0	11.7				
14.0	11.7				
16.0	11.7				
18.0	11.5	11.3			
20.0	10.4	10.3			
22.0	9.6	9.5	9.5		
24.0	8.7	8.8	8.8		
26.0	7.4	8.1	8.2	7.6	
28.0	6.3	7.0	7.7	7.2	
30.0	5.3	6.0	6.6	6.9	5.3
32.0	4.5	5.1	5.6	6.3	5.2
34.0	3.7	4.3	4.8	5.4	5.1
36.0	3.0	3.5	4.0	4.5	
38.0	2.4	2.8	3.2	3.7	
40.0	1.8	2.2	2.5		
42.0	1.3	1.6	1.8		
44.0		1.0			
(°)	32~ 81.5	30~ 81.5	40~ 81.5	54~ 81.5	67~ 81.5
F	50t hook (600kg)				
H	2part-line				

Unit: ton

29.8m boom					
B (m)	Offset				
	10°	20°	30°	45°	60°
16.0	8.0				
18.0	8.0				
20.0	8.0	8.0			
22.0	8.0	8.0			
24.0	7.7	7.7	7.7		
26.0	6.6	7.1	7.2		
28.0	5.4	6.3	6.7	6.9	
30.0	4.4	5.3	6.1	6.5	
32.0	3.5	4.4	5.1	6.0	6.0
34.0	2.7	3.5	4.2	5.0	5.6
36.0	2.0	2.7	3.4	4.2	4.7
38.0	1.3	2.0	2.6	3.3	3.8
40.0		1.3	1.9	2.5	
42.0				1.8	
(°)	52~ 81.5	53~ 81.5	56~ 81.5	57~ 81.5	66~ 81.5
F	8t hook (250kg)				
H	1part-line				

B= Working radius F= Standard hook H= No. of part-line

## Performance LC 1.6m + 27m luffing jib

Unit: ton

38.7m boom					
B (m)	Offset				
	10°	20°	30°	45°	60°
18.0	4.8				
20.0	4.8				
22.0	4.8	4.8			
24.0	4.8	4.8			
26.0	4.8	4.8	4.7		
28.0	4.8	4.8	4.6		
30.0	4.3	4.8	4.6	3.9	
32.0	3.4	4.3	4.5	3.8	
34.0	2.6	3.5	4.3	3.8	3.2
36.0		2.7	3.4	3.8	3.2
38.0		2.0	2.6	3.5	3.2
40.0			2.0	2.7	3.2
42.0				2.0	2.4
(°)	62~ 81.5	62~ 81.5	62~ 81.5	64~ 81.5	66~ 81.5
F	8t hook (250kg)				
H	1part-line				

Unit: ton

43.0m boom					
B (m)	Offset				
	10°	20°	30°	45°	60°
18.0	3.8				
20.0	3.8				
22.0	3.8	3.8			
24.0	3.8	3.8			
26.0	3.8	3.8	3.8		
28.0	3.8	3.8	3.8		
30.0	3.8	3.8	3.8	3.8	
32.0	3.3	3.8	3.8	3.8	
34.0	2.5	3.4	3.8	3.8	3.4
36.0		2.6	3.4	3.8	3.4
38.0			2.6	3.5	3.4
40.0				2.8	3.3
42.0				2.1	2.5
(°)	64~ 81.5	66~ 81.5	67~ 81.5	66~ 81.5	68~ 81.5
F	8t hook (250kg)				
H	1part-line				

B= Working radius F= Standard hook H= No. of part-line



## Performance LC 1.6m + 35m luffing jib

Unit: ton

16.6m boom					
B (m)	Offset				
	10°	20°	30°	45°	60°
14.0	9.5				
16.0	9.5				
18.0	9.5				
20.0	9.5	9.1			
22.0	9.0	8.5			
24.0	8.4	8.0			
26.0	7.8	7.5	7.0		
28.0	7.3	7.1	6.6		
30.0	6.4	6.7	6.2		
32.0	5.6	6.2	5.9	4.8	
34.0	4.9	5.4	5.5	4.6	
36.0	4.2	4.7	5.2	4.4	3.3
38.0	3.7	4.1	4.5	4.2	3.2
40.0	3.1	3.5	3.9	4.0	3.1
42.0	2.6	3.0	3.4	3.8	
44.0	2.1	2.5	2.8	3.2	
46.0	1.7	2.0	2.2		
48.0	1.3	1.5	1.7		
(°)	26~ 81.5	31~ 81.5	34~ 81.5	52~ 81.5	67~ 81.5
F	50t hook (600kg)				
H	2part-line				

Unit: ton

21.0m boom					
B (m)	Offset				
	10°	20°	30°	45°	60°
16.0	7.6				
18.0	7.6				
20.0	7.6				
22.0	7.6	7.6			
24.0	7.0	7.0			
26.0	6.4	6.4	6.5		
28.0	5.9	6.0	6.1		
30.0	5.5	5.6	5.7		
32.0	5.1	5.2	5.3	5.3	
34.0	4.4	4.9	5.0	5.1	
36.0	3.8	4.4	4.7	4.8	3.8
38.0	3.1	3.8	4.3	4.6	3.6
40.0	2.5	3.1	3.7	4.3	3.5
42.0	2.0	2.5	3.0	3.7	3.5
44.0	1.5	2.0	2.5	3.0	
46.0	1.1	1.5	1.9	2.4	
48.0		1.0	1.4	1.7	
(°)	40~ 81.5	41~ 81.5	45~ 81.5	49~ 81.5	67~ 81.5
F	8t hook (250kg)				
H	1part-line				

Unit: ton

29.8m boom					
B (m)	Offset				
	10°	20°	30°	45°	60°
18.0	5.4				
20.0	5.4				
22.0	5.4				
24.0	5.4	5.4			
26.0	5.4	5.4			
28.0	5.3	5.3	5.4		
30.0	4.8	4.9	5.0		
32.0	4.1	4.6	4.7		
34.0	3.3	4.3	4.4	4.6	
36.0	2.6	3.5	4.1	4.4	
38.0	1.9	2.8	3.6	4.1	4.0
40.0		2.1	2.9	3.9	3.9
42.0		1.6	2.3	3.2	3.8
44.0			1.7	2.5	3.1
46.0				1.9	2.3
(°)	59~ 81.5	59~ 81.5	61~ 81.5	63~ 81.5	66~ 81.5
F	8t hook (250kg)				
H	1part-line				

B= Working radius F= Standard hook H= No. of part-line

## Performance LC 1.6m + 35m luffing jib

Unit: ton

38.7m boom					
B (m)	Offset				
	10 °	20 °	30 °	45 °	60 °
20.0	3.3				
22.0	3.3				
24.0	3.3				
26.0	3.3	3.3			
28.0	3.3	3.3			
30.0	3.3	3.3	3.3		
32.0	3.3	3.3	3.3		
34.0	3.1	3.2	3.3		
36.0	2.4	3.0	3.1	3.0	
38.0		2.7	2.9	3.0	
40.0			2.7	3.0	2.5
42.0			2.2	2.9	2.5
44.0				2.5	2.5
46.0					2.5
48.0					1.9
( ° )	65 ~ 81.5	67 ~ 81.5	67 ~ 81.5	68 ~ 81.5	69 ~ 81.5
F	8t hook (250kg)				
H	1part-line				

Unit: ton

43.0m boom					
B (m)	Offset				
	10 °	20 °	30 °	45 °	60 °
20.0	2.5				
22.0	2.5				
24.0	2.5				
26.0	2.5	2.5			
28.0	2.5	2.5			
30.0	2.5	2.5			
32.0	2.5	2.5	2.5		
34.0	2.5	2.5	2.5		
36.0		2.5	2.5		
38.0		2.5	2.5	2.5	
40.0			2.5	2.5	
42.0				2.5	2.5
44.0				2.5	2.5
46.0					2.5
48.0					1.9
( ° )	68 ~ 81.5	69 ~ 81.5	71 ~ 81.5	72 ~ 81.5	71 ~ 81.5
F	8t hook (250kg)				
H	1part-line				

B= Working radius F= Standard hook H= No. of part-line

## WORKING RADIUS - LIFTING HEIGHT

1.6m + 11m luffing jib

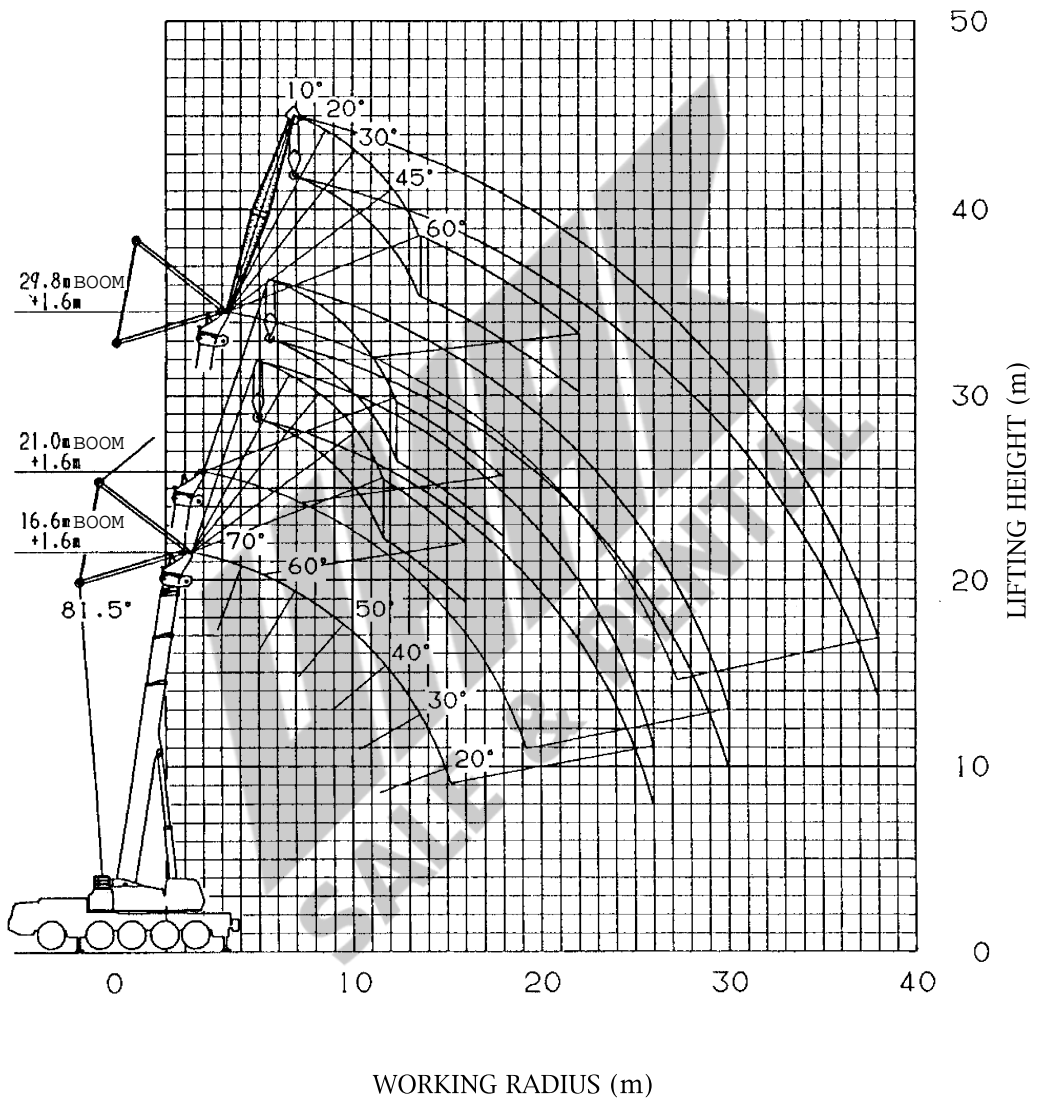

**NOTES:**

The deflection of the boom and the jib are not incorporated in the figure above.

1.6m + 19m luffing jib

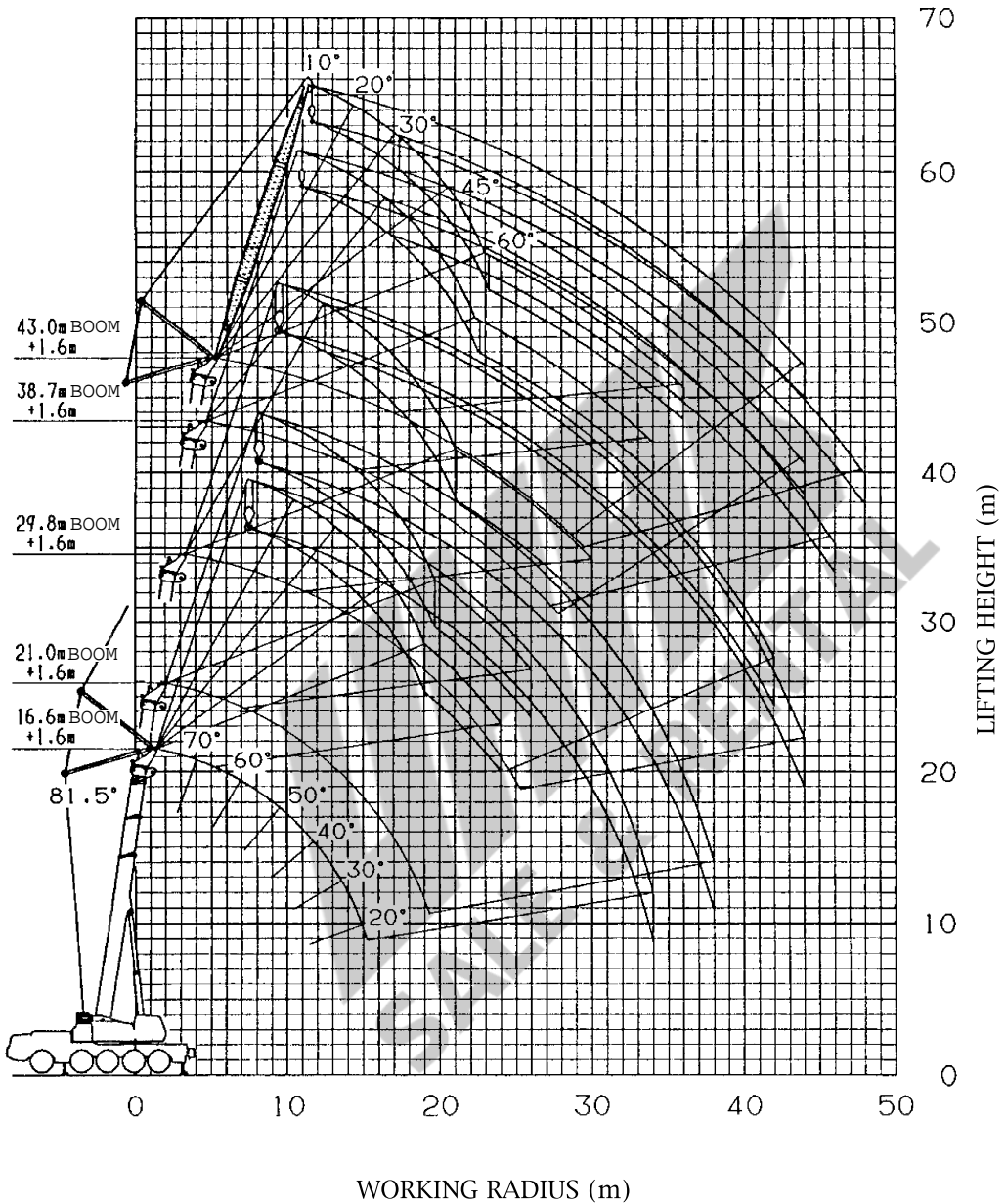

**NOTES:**

The deflection of the boom and the jib are not incorporated in the figure above.

## 1.6m + 27m luffing jib

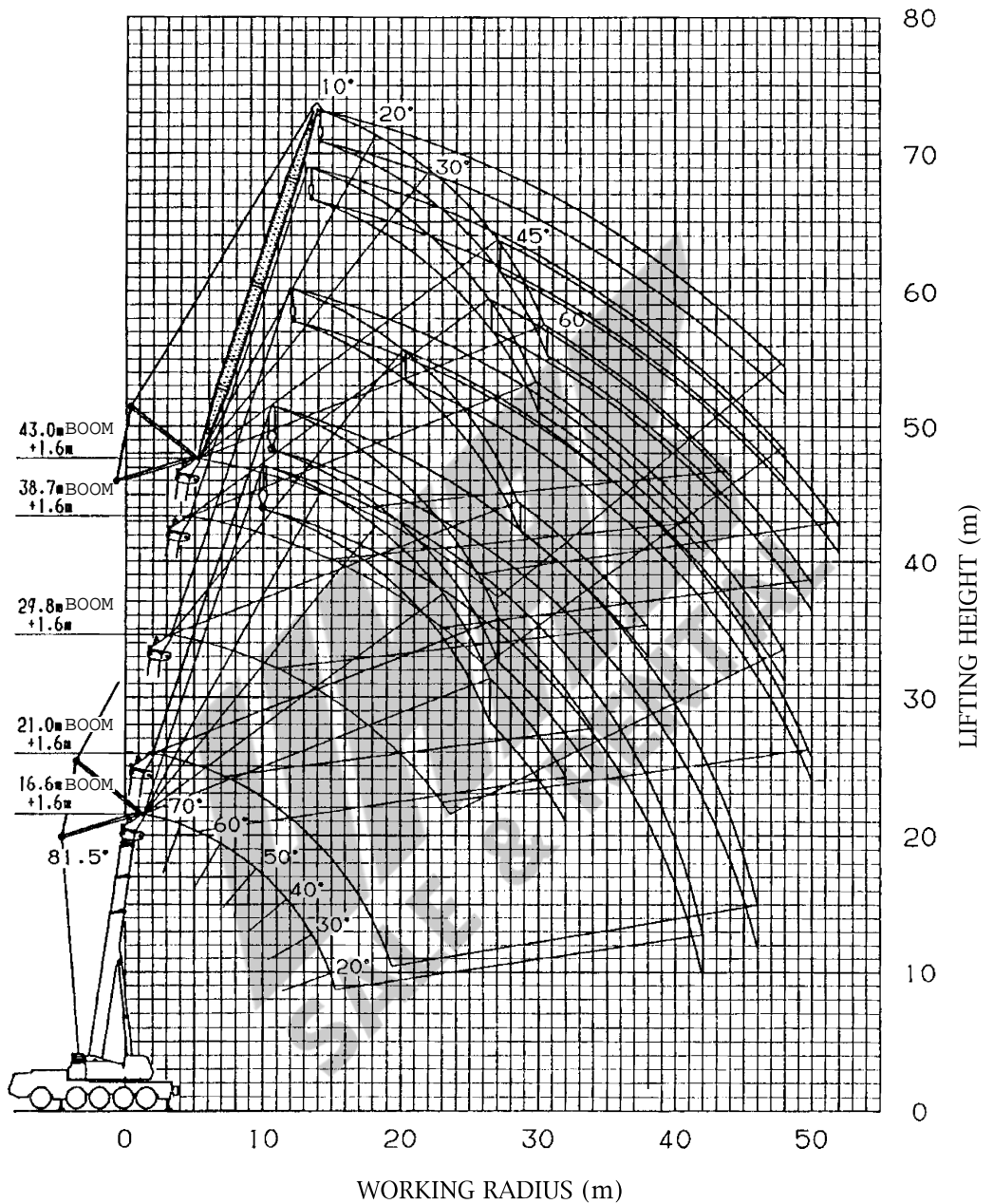
**NOTES:**

The deflection of the boom and the jib are not incorporated in the figure above.

1.6m + 35m luffing jib

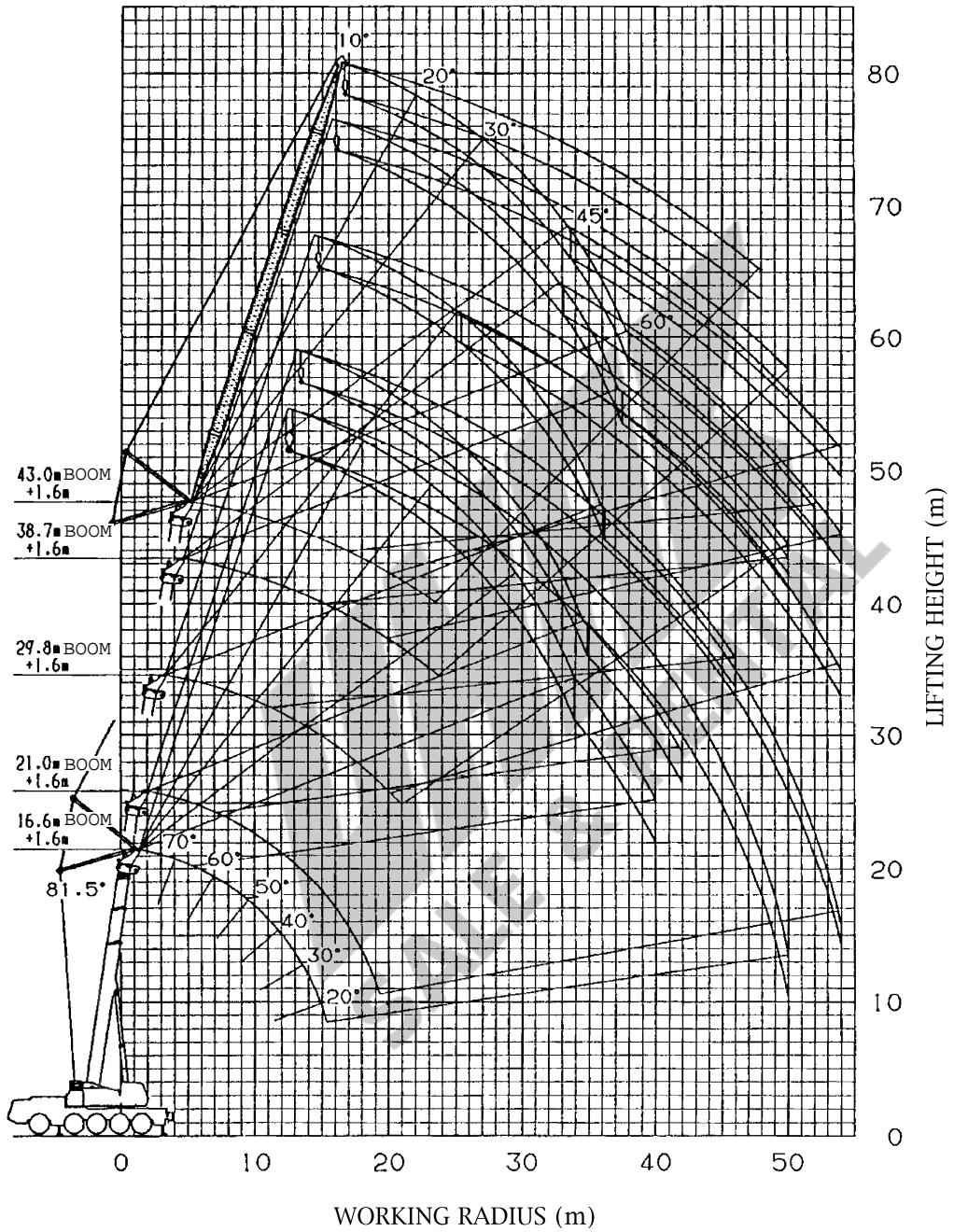

**NOTES:**

The deflection of the boom and the jib are not incorporated in the figure above.