

SUMITOMO



PAX Series

SC 800-2

80-M ton Hydraulic Crawler Crane

General Specifications & Crane/Luffing Tower Capacities

■ General Dimensions:

(in mm)

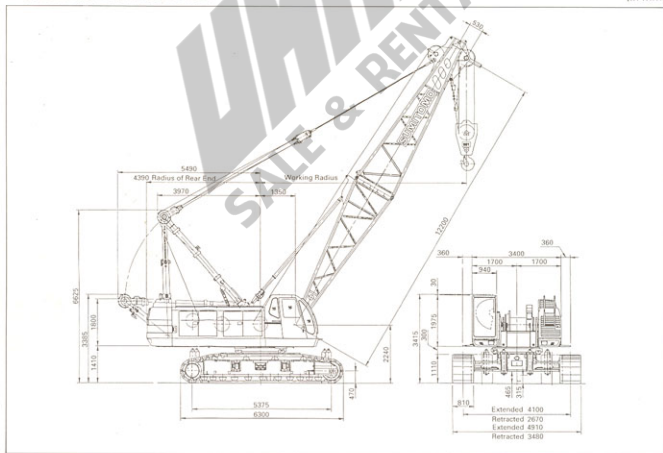

Basic Machine

Upper Machinery

UPPER FRAME:

All-welded, precision machined unit.

TURNTABLE BEARING WITH INTEGRAL RING GEAR:

Outer race is bolted to upper frame, inner race with internal ring gear is bolted to lower frame. Swing pinion meshes with internal, integral ring gear. A machined surface is provided for mounting turntable bearing.

CONTROL SYSTEM:

Remote controlled hydraulic servo for main hoist, aux. hoist, boom hoist, travel and swing. Working speed can be precisely controlled by grip type throttle.

PUMP CONTROL SYSTEM:

Motor cycle type SC throttle control provides two modes of engine and pump control.

Mode I — The SC controller is normally programmed to vary engine and pump discharge simultaneously, which enables both minute operation and maximum speed operation. This mode is suitable to precision crane work.

Mode II — By activating a switch, only pump discharge can be varied by means of the grip throttle, while keeping engine speed fixed.

Mode II is convenient for operation such as bucket work and lifting magnet etc., where engine is normally run at full throttle.

HYDRAULIC SYSTEM:

System combining three units of variable displacement axial pumps and one unit of fixed displacement gear pumps provides both independent and combined operations of all functions.

Main hoist/aux. hoist motor — Variable displacement axial piston motor with counterbalance valve.

Boom hoist motor — Axial piston motor with spring applied/hydraulically released multiple disc brake.

Swing motor — Axial piston motor with spring

applied/hydraulically released multiple disc brake.

Travel motor — Axial piston motors with brake valve. Spring applied/hydraulically released multiple disc brake is fitted.

Hydraulic oil reservoir — 380 liters capacity.

LOAD HOIST ASSEMBLY:

Front (main) and rear (aux.) operating drums. Each driven by the bi-directional, variable displacement axial piston motor through reduction gear powering the rope drum in either direction for hoisting or lowering load. Third drum is available as an optional extra.

Clutches — Spring loaded, internal expanding, hydraulically released clutches with non-asbestos linings.

Brakes — External contracting band type with non-asbestos lining operated by hydraulically assisted foot pedal with locking latch.

For crane mode, automatic brake (spring applied, hydraulically released) is applied when control lever in neutral position.

For bucket mode, free-fall is available when control lever in neutral position.

Locks — Electrically operated drum lock pawl.

BOOM HOIST ASSEMBLY:

Driven by the bi-directional, axial piston motor through reduction gear powering the rope drum in either direction for hoisting or lowering boom.

Brakes — Spring applied, hydraulically released multiple disc type.

Locks — Electrically operated drum lock pawl.

SWING:

Driven by two units of axial piston motor, through reduction gear.

Brakes — Brake is applied by spring and released by hydraulic cylinder.

Locks — Mechanically operated pin connection house lock.

Speed — 2.9 rpm.

Constant speed swing mechanism (option) — Selected with a switch, four modes of "constant speed" can be employed to prevent other operations.

OPERATOR'S CAB:

All new stamped automotive type fully air-conditioned full-vision, full compartment cab with large curved front window; the completely independent and rubber isolation mounted cab is insulated against noise and vibration.

COUNTERWEIGHT:

Removable, 4-block, mounted on rear of upper frame by bolts.

Crane

Crane Attachment

CRANE BOOMS:

Lattice construction; round tubular main chords, alloy, hi-ten steel, with bracing of round steel tubing.

Boom connections — In-line pin connections.

Basic Boom — Two-piece, 12.20 m basic length: 6.10 m bottom and 6.10 m top section; 1,550 mm deep and 1,550 mm wide at connections.

Boom point machinery — Four head sheaves mounted on antifriction bearings.

Boom extensions — Optional extra; available in 3.05 m, 6.10 m and 9.15 m lengths with pendants. Maximum boom length 57.90 m.

Basic fly Jib — Optional extra; two-piece; 9.15 m basic length with 4.575 m long bottom and top sections, 609 mm deep and 812 mm wide at connections.

Fly jib extension — Optional extra; available in 4.55 m. Maximum fly jib length 22.85 m.

Boom plus fly job length — 48.75 m + 22.85 m/51.80 m + 18.30 m (max.)

HOOK BLOCKS:

80 t with four sheaves — Optional extra.

50 t with two sheaves — Optional extra.

30 t with one sheave — Optional extra.

11 t ball hook — Optional extra.

TAGLINE WINDER:

Optional extra; for clamshell bucket job application.

Hydraulic type — mounted in front of upper revolving frame.

GANTRY:

Retractable high gantry.

DRUM DATA:

Drums	Root dia.	Type	Line Speed (Hoisting, lowering)	Cable dia.
Main hoist (Front)	530 mm	Parallel grooved	90 ~ 2 m/min.	26 mm
Aux. hoist (Rear)	530 mm	Parallel grooved	90 ~ 2 m/min.	26 mm
3rd drum	457 mm	Parallel grooved	65 ~ 4 m/min.	22.4 mm
Boom hoist	504 mm	Parallel grooved	46 ~ 2 m/min.	22.4 mm

Notes: 1. Above line speed varies with load.

2. Above line speed is based on first layer.

HOIST REEVING:

No. of parts of line	Max. load (t)							
	8	7	6	5	4	3	2	1
80 t hook	80.0	70.0	60.0	50.0	40.0	—	—	11.0
50 t hook	—	—	—	50.0	40.0	—	—	11.0
30/15 t hook	—	—	—	—	—	30.0	20.0	11.0
11 t hook	—	—	—	—	—	—	—	11.0

WORKING WEIGHT AND GROUND PRESSURE:

Shoe width	Weight	Pressure
810 mm	84.1 t	0.91 kg/cm ²

With basic boom and counterweight.

COUNTERWEIGHT:

26.9 t in total.

SAFETY DEVICES:

Hook over hoist limiting device, dual boom over hoist limiting device, boom angle indicator, boom backstops, electrically operated drum pawl lock for main/aux. and boom hoist drum, swing warning flash lamps with buzzer, fool proof shut off main hydraulic line, individual control lever locks, safe and durable non-asbestos lining, key lock mode selector switch, non-skid surfaces on roof, Load Moment Limiter with annunciator-type overload preventing system, and optional three color percentage indicator on load weighing device.

GRADEABILITY:

30% (17°) with basic boom and counterweight.

■ CRANE CAPACITIES :

Working radius (m)	Boom length															
	12.20	15.25	18.30	21.35	24.40	27.45	30.50	33.50	36.55	39.60	42.65	45.70	48.75	51.80	54.85	57.90
4.0	80.0															
4.5	73.2	73.1/4.6														
5.0	60.7	60.7														
6.0	45.1	45.1	60.6/5.1	45.1	45.1	44.9/6.1										
7.0	35.8	35.8	35.8	35.7	35.6	35.6	32.6/7.5									
8.0	29.9	29.8	29.7	29.6	29.5	29.4	29.3	29.2	27.0/8.5							
9.0	25.5	25.4	25.3	25.2	25.1	25.0	24.9	24.8	24.8	24.7						
10.0	21.9	21.8	21.7	21.7	21.6	21.6	21.5	21.4	21.4	21.3	21.2	21.1	18.4/11.0	18.3/11.0		
12.0	17.2	17.1	17.1	17.0	17.0	16.9	16.9	16.8	16.7	16.6	16.5	16.4	16.3	16.2	16.1	15.2
14.0	17.1/12.1	14.2	14.1	14.0	13.9	13.8	13.7	13.6	13.5	13.4	13.3	13.2	13.1	13.0	12.9	12.8
16.0		13.4/14.8	11.8	11.7	11.6	11.5	11.4	11.3	11.2	11.1	11.0	10.9	10.8	10.7	10.6	10.5
18.0			10.6/17.4	10.0	9.9	9.8	9.7	9.6	9.5	9.4	9.3	9.2	9.1	9.0	8.9	8.8
20.0				8.7	8.6	8.5	8.4	8.3	8.2	8.1	8.0	7.9	7.8	7.7	7.6	7.5
22.0					7.6	7.5	7.4	7.3	7.2	7.1	7.0	6.9	6.8	6.7	6.6	6.5
24.0					7.2/22.7	6.6	6.5	6.4	6.3	6.2	6.1	6.0	5.9	5.8	5.7	5.6
26.0						6.2/25.2	5.8	5.7	5.6	5.5	5.4	5.3	5.2	5.1	5.0	4.9
28.0							5.2	5.1	5.0	4.9	4.8	4.7	4.6	4.5	4.4	4.3
30.0								4.6	4.5	4.4	4.3	4.2	4.1	4.0	3.9	3.8
32.0								4.5/30.5	4.0	3.9	3.8	3.7	3.6	3.5	3.4	3.3
34.0									3.8/33.0	3.5	3.4	3.3	3.2	3.1	3.0	2.9
36.0										3.2/35.8	3.1	3.0	2.9	2.8	2.7	2.5
38.0											2.8	2.7	2.6	2.4	2.3	2.1
40.0											2.8/38.5	2.4	2.2	2.0	1.9	1.7

Notes:

1. Capacities shown are in metric tons and are based on 78% of minimum tipping loads—over the side—with machine standing level on firm supporting surface under ideal job conditions unless marked with a shaded color (■) that indicates capacities are based on factors other than those which would cause a tipping condition. Deductions from the lifting crane capacities must be made for weight of hook block, and other suspended gear.

Kind of hook block	80 t	50 t	30 t	11 t
Weight of hook block (t)	0.9	0.9	0.73	0.4

- Side frame must be extended for all operating conditions and gantry must also be set to high position.
- Capacities shown above are based on 26.9t counterweight.
- All capacities are rated for 360° swing.

■ WORKING RANGES FOR CRAWLER CRANE :

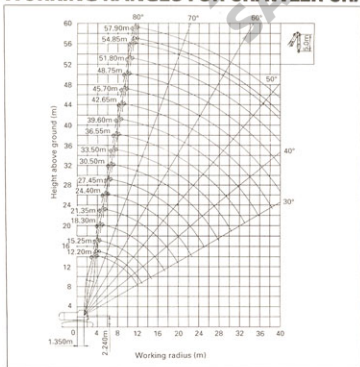

■WORKING RANGES FOR CRAWLER CRANE WITH FLY JIB :

