



Upper Machinery

UPPER FRAME: All-welded, precision machined unit.

TURNTABLE BEARING WITH INTEGRAL RING GEAR:

Outer race is bolted to upper frame, inner race with internal ring gear is bolted to lower frame. Swing pinion meshes with internal, integral ring gear. A machined surface is provided for mounting turntable bearing.

CONTROL SYSTEM: Remote controlled hydraulic servo for main hoist, aux. hoist and travel. Mechanical linkage type for swing. Working speed can be precisely controlled by lever stroke.

PUMP CONTROL SYSTEM: System reducing pump displacement enables both minute operation and saving energy.

HYDRAULIC SYSTEM: System combining two variable displacement axial piston pumps and two (three; option) fixed displacement gear pumps provides both independent and combined operations of all functions.

Main hoist/aux. hoist/boom hoist – Axial piston motor with counterbalance valve.

Swing motor – Axial piston motor.

Travel motor – Axial piston motors with brake valves. Spring-set/hydraulic-released multiple disc brakes are fitted.

Hydraulic oil reservoir – 295 liter capacity.

LOAD HOIST ASSEMBLY: Front (main) and rear (aux.) operating drums. Each driven by the bi-directional, axial piston motor through reduction gear powering the rope drum in either direction for hoisting or lowering load. 3rd drum equipped as optional extra.

Clutches – Power hydraulic actuated, internal expanding, self adjusting 2-shoe type.

Brakes – External contracting band type operated by foot pedal with locking latch. For crane lifting operation, automatic brake (spring applied, hydraulically released) is applied when control lever in neutral position. For bucket mode, free-fall is available when control lever in neutral position.

Locks – Electrically operated drum lock pawl.

BOOM HOIST ASSEMBLY: Driven by the bi-directional, axial piston motor through reduction gear powering the rope drum in either direction for hoisting or lowering boom.

Brake – Spring applied, hydraulically released multiple disc brake.

Lock – Electrically operated drum lock pawl.

SWING: Driven by axial piston motor, through reduction gear.

Brake – Brake is applied by spring and released by hydraulic cylinder.

Lock – Mechanically operated pin connection frame lock.

Speed – 2.8 rpm

OPERATOR'S CAB: Full vision compartment with safety glass panels, the completely independent cab is insulated against noise and vibration.

COUNTERWEIGHT: Removable, 2 blocks mounted on rear end of upper frame by bolts. Counterweight removal device is available as option.

POWER UNIT:

Make & Model	HINO HO6CT
Type	Water-cooled, 4-cycle diesel engine
No. of cylinders	6
Rated output	150 ps/2,100 rpm
Max. torque	52 kg-m/1,600 rpm
Fuel tank	290 liters

Lower Machinery

LOWER FRAME: All welded robust rolled steel, box construction.

SIDE FRAMES: All welded robust rolled steel. Connected to lower frame by links & pins. Retracted or extended by hydraulic cylinder.

ROLLERS: Heat treated, double flanged, mounted on bushings with floating seals requiring no further lubrication.

Bottom – 10 pcs. per side frame.

Top – 3 pcs. per side frame.

DRIVE SPROCKETS: Heat treated, involute splined to drive shaft mounted on antifriction bearings.

IDLERS: Heat treated, mounted on bushings with floating seals requiring no further lubrication.

TRACKS: Heat treated, self cleaning, single lug, multiple hinged shoes, 50 pcs. per side frame.

Shoe width – 810 mm (standard)

Tractor type link shoe (55 pcs. per side frame) is available as option.

TRACK TENSION ADJUSTER: Adjusted by hydraulic cylinders at the idler blocks. Tension can be automatically released when abnormal load occurred on tracks.

TRAVEL AND STEER: Axial piston motor with reduction gear is located at inner drive end of each crawler side frame. Each track is driven simultaneously or individually for straight-line travel, or pivot turn, or the tracks can be counter-rotated for spin turns.

Brake – Spring applied, hydraulically released multiple disc brakes applied automatically when control lever in neutral position.

Speed – 4 speed range

1.7/1.0 km/h . . . Pump control "OFF" (ordinary)

0.4/0.19 kg/h . . . Pump control "ON"

General Dimensions

- A: Height over low gantry unit 3.395m
- A': Height over high gantry unit 5.595m
- B: Height of cab 3.215m
- C: Counterweight ground clearance 1.120m
- D: Radius of rear end 4.165m
- E: Center of rotation to boom foot pin 1.000m
- F: Center to center distance of tumbler 5.000m
- G: Overall length of crawler 5.925m
- H: Height from ground to boom foot pin 1.735m
- I: Overall width of house 3.090m
- J: Ground clearance 0.410m
- K: Center to center distance of crawler 3.850m
 - extended . . . 3.850m
 - retracted . . . 2.660m
- L: Overall width of crawler 4.660m
 - extended . . . 4.660m
 - retracted . . . 3.470m
- M: Shoe width 0.810m
- N: Height of shoe (standard) 1.025m
- O: Tail swing radius at low gantry 4.790m

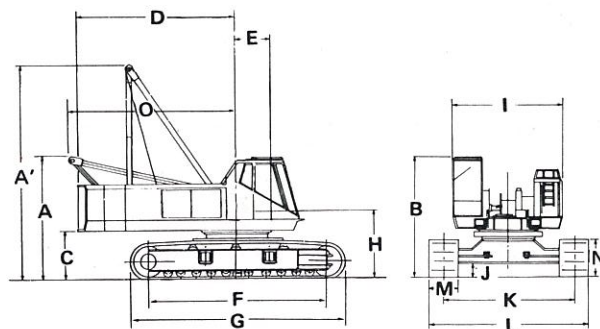

We are constantly improving our products and therefore reserve the right to change designs and specifications.

SUMITOMO (S.H.I.) CONSTRUCTION MACHINERY CO., LTD.

International sales Div., 1-21, Kanda, Nishiki-cho, Chiyoda-ku, Tokyo, Japan
 Telex: J27961 (AAB: SHIKENKI) Fax: Tokyo (03) 233-0138 Phone: (03) 296-5284



CRANE BOOMS: Lattice construction; round tubular main chords, alloy hi-ten steel, with bracing of round steel tubing.

- Boom connections In-line pin connections.
 - Basic boom Two-piece, 12.2m basic length; 6.1m base and 6.1m top section; 1.2m deep and 1.27m wide at connections.
 - Boom point machinery Five head sheaves mounted on antifriction bearings.
 - Boom extensions Available in 3.05m, 6.1m and 9.15m lengths with pendants. Maximum boom length 54.85m.
 - Jib Two-piece; 9.15 m basic length with 4.6m long base and top sections, available in 4.6 m jib extension. Maximum jib length 18.3 m.
 - Boom plus jib length 42.70m + 18.3m
- Angle main chords, with bracing of angle steel is available as option.

HOOK BLOCK:

- 65 t, five sheaves Standard
- 20 t, one sheave Optional extra
- 6.5 t, no sheave Optional extra

HIGH GANTRY: Retractable high gantry.

LINE SPEED:

Drums	Root dia.	Type	Line speed (Hoisting, Lowering)		Cable dia.
			Pump control "OFF" (Ordinary)	Pump control "ON"	
Main hoist (Front)	448mm	Parallel grooved	High 80 m/min Low 40 m/min	High 15 m/min Low 7.5 m/min	22.4mm
Aux. hoist (Rear)	448mm	Parallel grooved	High 80 m/min Low 40 m/min	High 15 m/min Low 7.5 m/min	22.4mm
3rd drum (option)	320mm	Parallel grooved	65 m/min	12 m/min	16mm
Boom hoist	320mm	Parallel grooved	66 m/min	12 m/min	16mm

Hoisting line speed varies with load.

HOIST REEVING:

No. of parts of line	Main hoist									
	10	9	8	7	6	5	4	3	2	1
Max. load (t)	65	58.5	52	45.5	39	32.5	26	19.5	13	6.5

WORKING WEIGHT AND GROUND PRESSURE:

Shoe width	Weight	Pressure
810mm (standard)	58.5t	0.67 kg/cm ²
810mm (tractor type)	61.5t	0.71 kg/cm ²

With basic boom and counterweight.

Weight without counterweight and front attachment: approx. 34t (with standard shoe)

COUNTERWEIGHT: "A" 10.85 t, "B" 9.15 t. Total 20 t

SAFETY DEVICE: Hook over hoist limiting device, boom over hoist limiting device, boom angle indicator, boom back stop, drum pawl lock for main, aux. and boom hoist drum, load moment limiter (option)

GRADEABILITY: 30% (17°)

We are constantly improving our products and therefore reserve the right to change designs and specifications.

SUMITOMO (S.H.I.) CONSTRUCTION MACHINERY CO., LTD.

International sales Div., 1-21, Kanda, Nishiki-cho, Chiyoda-ku, Tokyo, Japan
 Telex: J27961 (AAB: SHIKENKI) Fax: Tokyo (03) 233-0138 Phone: (03) 296-5284

LS-120RH₅ CRANE CAPACITIES:

(in metric tons)

Working radius (m)	Boom length (m)														
	12.20	15.25	18.30	21.35	24.40	27.45	30.50	33.55	36.60	39.65	42.70	45.75	48.80	51.85	54.85
3.7	65.0														
4.0	65.0	63.1													
4.5	55.0	54.0													
5.0	44.8	44.6	44.5												
5.5	38.4	38.3	38.2	38.1											
6.0	33.6	33.5	33.4	33.3	33.2										
7.0	26.7	26.6	26.5	26.4	26.3	26.2	26.1								
8.0	22.1	22.0	21.9	21.8	21.7	21.6	21.5	21.4	21.3						
9.0	18.9	18.8	18.7	18.6	18.5	18.4	18.3	18.2	18.1	18.0	17.8				
10.0	16.5	16.4	16.3	16.2	16.1	16.0	15.9	15.8	15.7	15.6	15.5	15.4	14.8		
12.0	^{13.4} / _{11.7}	12.8	12.7	12.6	12.5	12.4	12.3	12.2	12.1	12.0	11.9	11.8	11.7	11.6	
14.0		10.5	10.4	10.3	10.2	10.1	10.0	9.9	9.8	9.7	9.6	9.5	9.4	9.3	9.2
16.0			8.7	8.6	8.5	8.4	8.3	8.2	8.1	8.0	7.9	7.8	7.7	7.6	7.5
18.0				7.4	7.3	7.2	7.1	7.0	6.9	6.8	6.7	6.6	6.5	6.4	6.3
20.0				^{6.6} / _{19.6}	6.3	6.2	6.1	6.0	5.9	5.8	5.7	5.6	5.5	5.4	5.3
22.0					5.5	5.4	5.3	5.2	5.1	5.0	4.9	4.8	4.7	4.6	4.5
24.0						4.7	4.6	4.5	4.4	4.3	4.2	4.1	4.0	3.9	3.8
26.0						^{4.3} / _{24.9}	4.1	4.0	3.9	3.8	3.7	3.6	3.5	3.4	3.3
28.0							^{3.7} / _{27.5}	3.6	3.5	3.4	3.3	3.2	3.1	3.0	2.9
30.0								3.2	3.1	3.0	2.9	2.8	2.7	2.6	2.5
32.0									2.8	2.7	2.6	2.5	2.4	2.3	2.2
34.0										2.5	2.4	2.3	2.2	2.1	2.0
36.0										^{2.2} / _{35.4}	2.2	2.1	2.0	1.9	1.8
38.0											2.0	1.9	1.8	1.7	1.6

Notes:

- Capacities shown are in metric tons and are based on 75% of minimum tipping loads – over the side – with machine standing level on firm supporting surface under ideal job conditions. Deductions from the lifting crane capacities must be made for weight of hook block.

Kind of hook block	65t	20t	6.5t
Weight of hook block (t)	0.8	0.4	0.3

- Side frame must be extended for all operating conditions.
- When handling loads by main hoist line on boom with jib fitted, the following deductions must be made from above crane capacities.

Jib length (m)	9.15	13.70	18.30
Weight to be deducted (t)	1.5	2.1	2.8

Crane 65 metric tons



LS-120RH5 CRANE WORKING RANGES:

