

**HEAVY DUTY BASE MACHINE
FOR FOUNDATION WORK**

BM1000 HD

KOBELCO

Model: BM1000HD

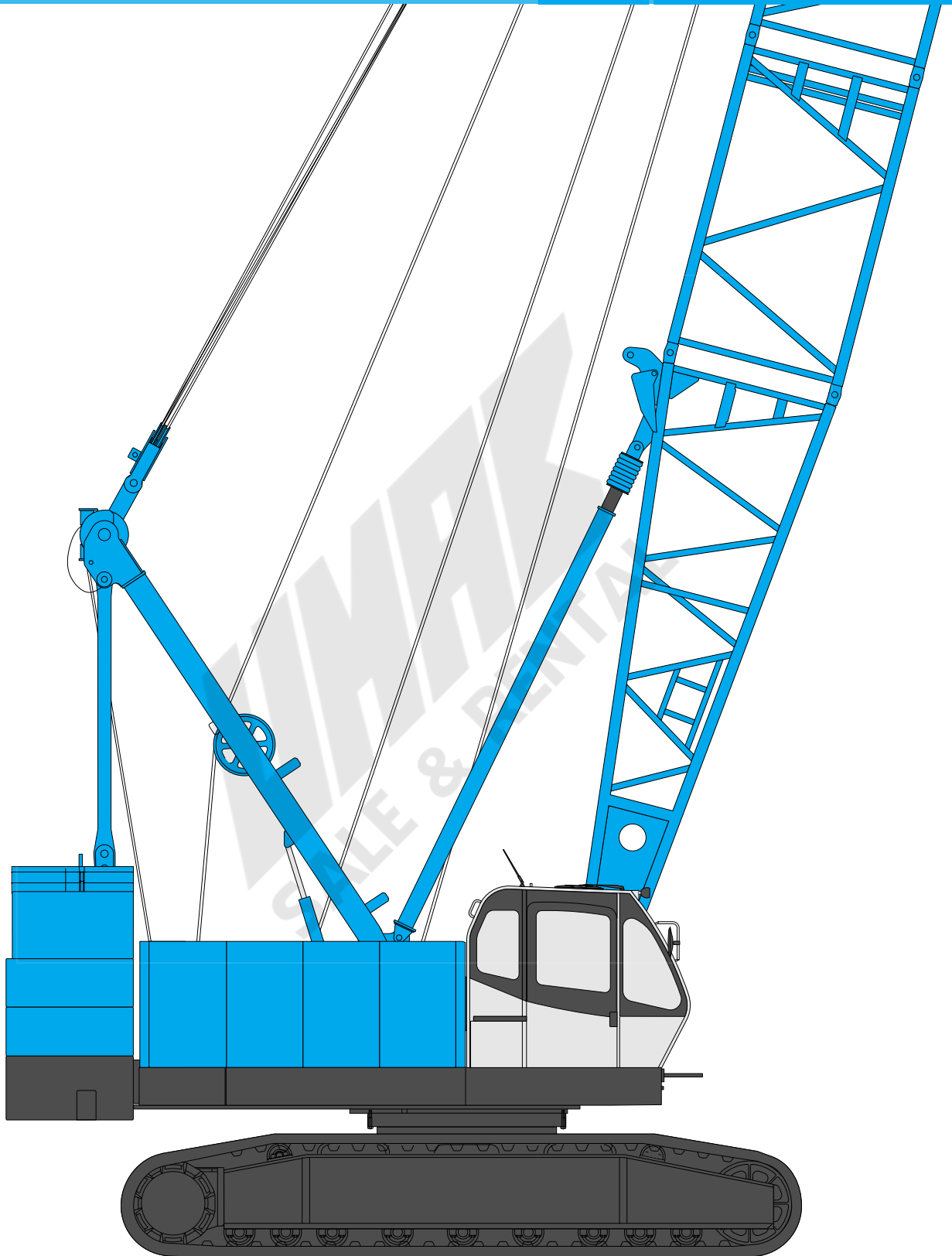

**Max. Lifting Capacity: 100 t x 3.8 m
Max. Crane Boom Length: 62.6 m**

CONFIGURATION

Crane Boom

Max. Lifting Capacity:
100 metric ton x 3.8 m
Max. Boom Length:
62.6 m



Clamshell

Max. Lifting Capacity:
12.5 metric ton x 13.0 m
Max. Boom Length:
26.0 m

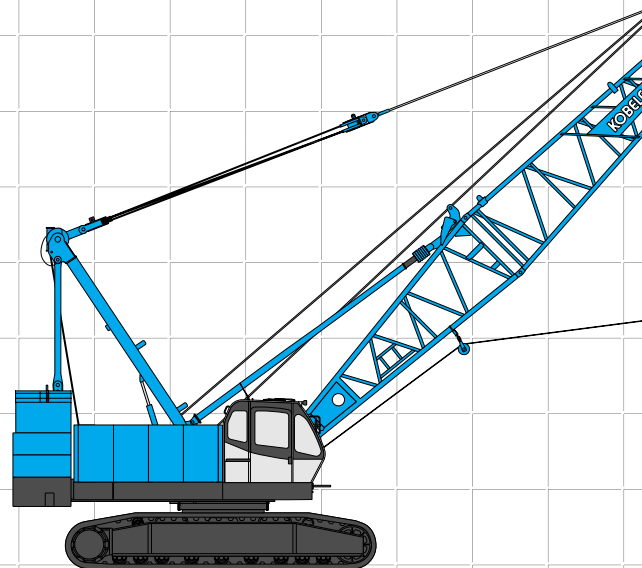
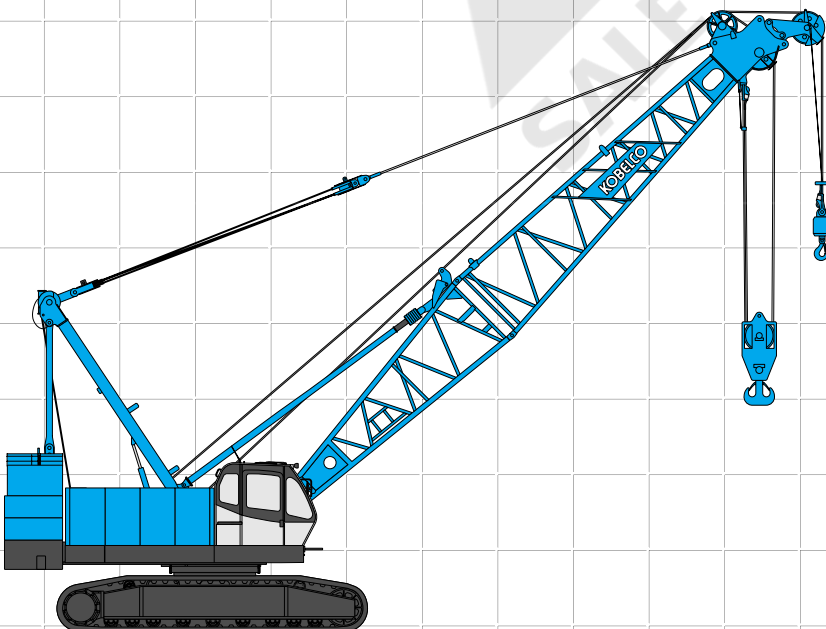

HEAVY DUTY BASE MACHINE FOR FOUNDATION WORK BM1000 HD

Hammer Grab

Boom Length:

23.0 m

Lifting Capacity at 7.0 m:

50.9 ton

*Recommended Specification
for Casing Diameter: 2,000 mm

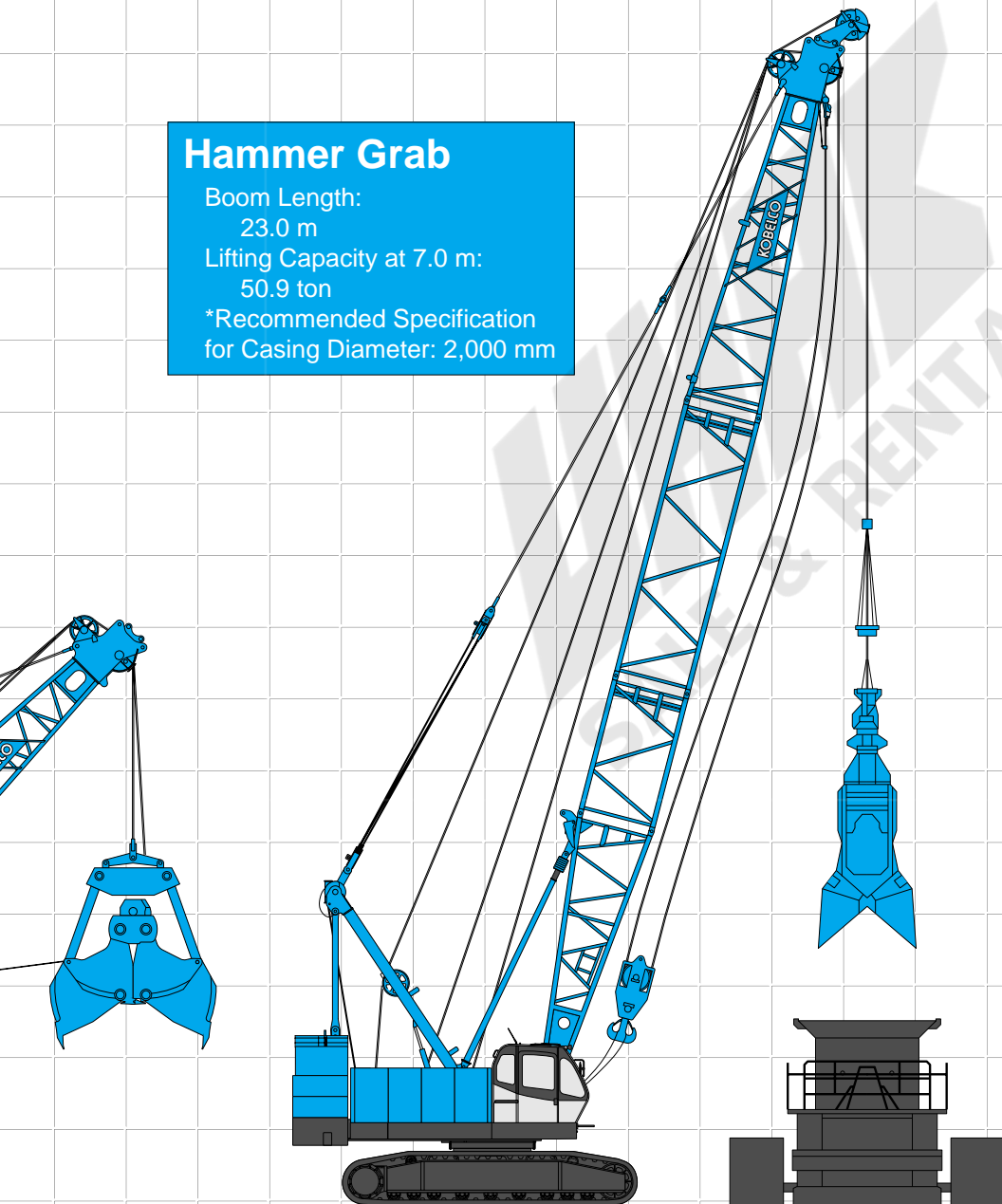

CONTENTS

Configuration 1

Specifications 3

General Dimensions 5

Boom Arrangements 6

Working Ranges and Lifting Capacities

Crane Boom

Working Ranges 8

Crane Boom

Lifting Capacity 9

Auxiliary Sheave

Lifting Capacity

for Crane Boom 10

Clamshell 11

Parts and Attachments ... 12

SPECIFICATIONS



Power Plant

Model: Hino diesel engine P11C-UN
Type: Water-cooled, direct fuel injection, with turbocharger
Complies with NRMM (Europe) stage IIIA and US EPA Tier III.
Displacement: 10.520 liters
Rated Power: 247 kW at 2,000 min⁻¹ {rpm} (ISO)
Max. torque: 1,300 N·m/1,500 min⁻¹
Cooling system: Liquid, recirculating bypass
Starter: 24 V/6.0 kW
Radiator: Corrugated type core, thermostatically controlled
Air cleaner: Dry type with replaceable paper element
Throttle: Electric throttle control, twist grip type
Fuel filter: Replaceable paper element
Batteries: Two 12V, 136 Ah/5HR capacity batteries, series connected.
Fuel tank capacity: 400 liters



Hydraulic System

Three variable displacement piston pumps are driven by heavy-duty pump drive. Two of variable displacement pumps are used in the main hook hoist circuit, boom hoist circuit, auxiliary hook hoist circuit and each propel circuit. The other is used in the swing circuit.

Control: Full-flow hydraulic control system for infinitely variable pressure to front and rear drums, boom hoist brakes and clutches. Controls respond instantly to the touch, delivering smooth function operation.

Cooling: Oil-to-air heat exchanger (plate-fin type)

Filtration: Full-flow and bypass type with replaceable element

Electrical system: All wiring corded for easy servicing, individual fused branch circuits.

Max. relief valve pressure:

Load hoist, boom hoist and propel system:

31.9 MPa {325 kgf/cm²}

Swing system: 27.5 MPa {280 kgf/cm²}

Control system: 7.0 MPa {71 kgf/cm²}

Reservoir capacity: 440 liters



Boom Hoisting System

Powered by a hydraulic motor through a planetary reducer.

Brake: A spring-set, hydraulically released multiple-disc brake is mounted on the boom hoist motor and operated through a counter-balance valve.

Drum lock: External ratchet for locking drum

Drum: Single drum, grooved for 20 mm dia. wire rope

Line speed: Single line on first drum layer

Hoisting, Lowering: 50 to 3 m/min

Diameter of wire ropes

Boom guy line: 34 mm

Boom hoist reeving: 10 parts of 20 mm dia. high strength wire rope

Boom backstops: Required for all boom lengths



Load Hoist System

Front and rear drums for load hoist powered by a hydraulic variable plunger motors, driven through planetary reducers.

Positive & Negative Brake: Forced-circulation oil-cooled wet-type multi-disc brake, each using positive and negative actuation. The drums are manually locked by the control cable. Both positive and negative brake systems are available in lever neutral position.

Drum lock: External ratchet for locking drum.

Drums:

Front drum:

616 mm P.C.D. x 620 mm Lg. wide drum, grooved for 28 mm wire rope. Rope capacity is 200 m working length and 284 m storage length.

Rear drum:

616 mm P.C.D. x 620 mm Lg. wide drum, grooved for 28 mm wire rope. Rope capacity is 130 m working length and 284 m storage length.

Note: Rope lengths listed above denote drum capacity and may differ from actual rope lengths supplied when machinery is shipped.

Line speed: Single line on the first drum layer

Hoisting, Lowering: 110 to 3 m/min

Line Pull (Single-line):

Rated line pull: 132 kN {13.5 tf}

Max. line pull: 252.9 kN {25.8 tf} (1st layer)

Note: Max. line pull is theoretical values under certain test condition.



Swing System

Swing unit is powered by hydraulic motor driving spur gear through planetary reducer, the swing system provides 360° rotation.

Swing parking brakes: A spring-set, hydraulically released multiple-disc brake is mounted on swing motor.

Swing circle: Single-row ball bearing with an integral internally cut swing gear.

Swing lock: Manually, four position lock for transportation

Swing speed: 3.2 min⁻¹ {rpm}



Upper Structure

Torsion-free precision machined upper frame. All components are located clearly and service friendly. Engine with low noise level.

Counterweight: 37.8 ton



Cab & Control

Totally enclosed, full vision cab with safety glass, fully adjustable, high backed seat with a head-rest and armrests, and intermittent wiper and window washer (skylight and front window).

Cab fittings:

Air conditioner, convenient compartment (for tool), cup holder, ashtray, cigarette lighter, sun visor, roof blind, tinted glass, floor mat, foot-rest, shoe tray

Controls:

Four adjustable levers for front drum, rear drum, boom drum and swing controls.



Lower Structure

Steel-welded carbody with axles. Crawler assemblies are designed with quick disconnect feature for individual removal as a unit from axles. Also crawler assemblies can be hydraulically extended for wide-track operation or retracted for transportation. Crawler belt tension is maintained by hydraulic jack force on the track-adjusting bearing block.

Carbody weight: 6.8 t

Crawler weight: 3.2 t

Crawler drive: Independent hydraulic propel drive is built into each crawler side frame. Each drive consists of a hydraulic motor propelling a driving tumbler through a planetary gear box. Hydraulic motor and gear box are built into the crawler side frame within the shoe width.

Crawler brakes: Spring-set, hydraulically released parking brakes are built into each propel drive.

Steering mechanism: A hydraulic propel system provides both skid steering (driving one track only) and counter-rotating steering (driving each track in opposite directions).

Track rollers: Sealed track rollers for maintenance-free operation.

Shoes (flat): 59 shoes, 900 mm wide each crawler

Max. travel speed: 1.5/1.0 km/h

Max. gradeability: 30%



Weight

Including upper and lower machine, 37.8 ton counterweight, 6.8 t carbody weight, 3.2 t crawler weight, basic boom, hook, and other accessories.

| Specification | Weight | Ground pressure |
|-------------------|--------------------|---------------------------------------|
| Crane boom | Approx. 107.4 ton, | 109.7 kPa {1.12 kgf/cm ² } |



Attachment

Boom

Welded lattice construction using tubular, high-tensile steel chords with pin connections between sections.

Boom Length

| | Crane Boom |
|------------|------------|
| Basic Boom | 13.8 m |
| Max. Boom | 62.6 m |

Main Specifications (Model: BM1000HD)

| Crane Boom | |
|---------------------------------|---|
| Max. Lifting Capacity | 100 t/3.8 m |
| Max. Length | 62.6 m |
| Main & Aux. Winch | |
| Max. Line Speed | 110 m/min (1st layer) |
| Rated Line Pull (Single-line) | 132 kN {13.5 tf} |
| Max. Line Pull (Single-line)*** | 252.9 kN {25.8 tf} (1st layer) |
| Wire Rope Diameter | 28 mm |
| Wire Rope Length | 200 m (Main) 130 m (Aux.) |
| Brake Type | Forced-circulation oil-cooled wet-type multi-disc brake (Positive & Negative) |
| Working Speed | |
| Swing Speed | 3.2 min ⁻¹ {rpm} |
| Travel Speed | 1.5/1.0 km/h |
| Power Plant | |
| Model | Hino P11C-UN |
| Engine Output | 247 kW/2,000 min ⁻¹ |
| Fuel Tank Capacity | 400 liters |

| Hydraulic System | |
|-------------------------|--|
| Main Pumps | 3 variable displacement |
| Max. Pressure | 31.9 MPa {325 kgf/cm ² } |
| Hydraulic Tank Capacity | 440 liters |
| Weight | |
| Operating Weight* | Approx. 107.4 t |
| Ground Pressure* | 109.7 kPa {1.12 kgf/cm ² } |
| Counterweight | 37.8 t (Upper) + 6.8 t (Lower) + 3.2 t (Crawler) |
| Transport Weight** | Approx. 35.7 t |

* Including upper and lower machine, 37.8 ton counterweight, 6.8 t carbody weight, 3.2 t crawler weight, basic boom, hook and other accessories.

** Base machine with gantry, boom base, carbody, main and aux. winch with wire ropes, lower spreader and upper spreader (Refer to notes P12).

*** Max. line pull is theoretical values under certain test condition.

Units are SI units. { } indicates conventional units.

GENERAL DIMENSIONS

Crane Boom

(Unit: mm)

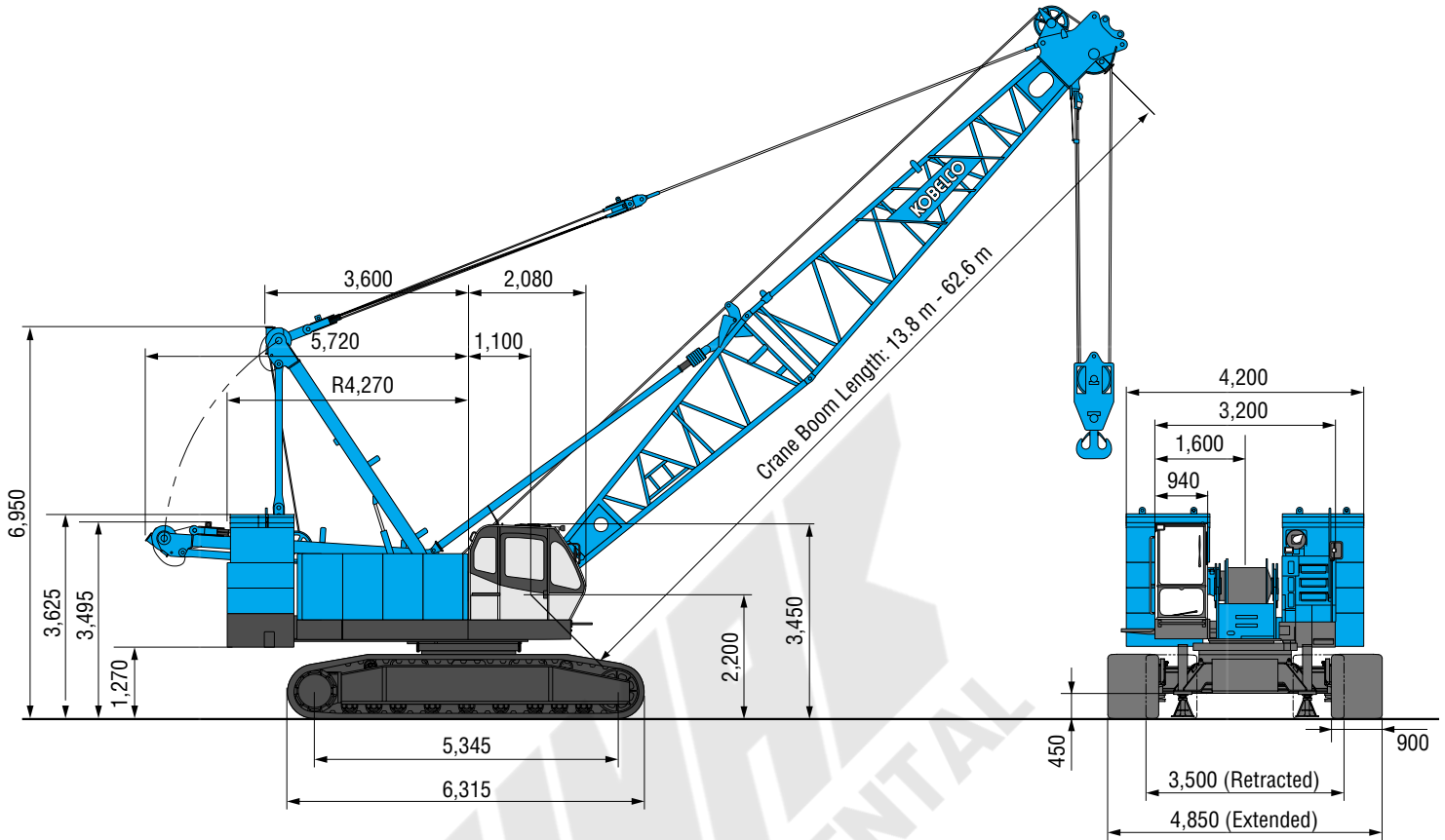

Limit of Hook Lifting

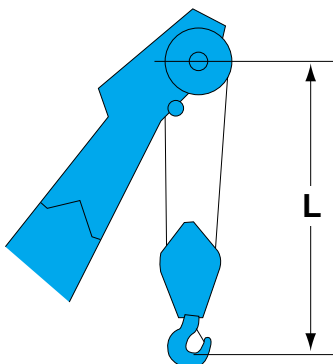

| Hook | L |
|------------|-------|
| 100 t hook | 5.0 m |
| 50 t hook | 5.0 m |
| 35 t hook | 5.0 m |

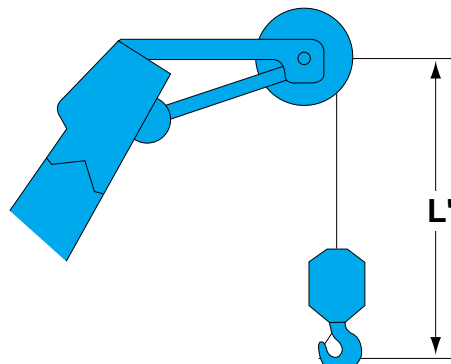

| Hook | L' |
|------------------|-------|
| 13.5 t ball hook | 4.2 m |

BOOM ARRANGEMENTS

HEAVY DUTY BASE MACHINE
FOR FOUNDATION WORK
BM1000 HD

Crane Boom Arrangements

| Boom length m (ft) | Boom arrangement |
|--------------------|------------------|
| 13.8 (45) | |
| 16.9 (55) | |
| 19.9 (65) | |
| 23.0 (75) | |
| 26.0 (85) | |
| 29.1 (95) | |
| 32.1 (105) | |
| 35.2 (115) | |
| 38.2 (125) | |

| Boom length m (ft) | Boom arrangement |
|--------------------|------------------|
| 41.2 (135) | |
| 44.3 (145) | |
| 47.3 (155) | |
| 50.4 (165) | |
| 53.4 (175) | |
| 56.5 (185) | |
| 59.5 (195) | |
| 62.6 (205) | |

| Symbol | Boom Length | Remarks |
|--------|-------------|-------------|
| | 6.2 m | Boom Base |
| | 7.6 m | Boom Top |
| | 3.0 m | Insert Boom |
| | 6.1 m | Insert Boom |
| | 9.1 m | Insert Boom |

※ mark shows the standard boom arrangement which enables each boom length of less than that boom length to be configured.



Hook Blocks

A range of hook blocks can be specified, each with a safety latch.

| Hooks | Weight (kg) | No. of sheaves | No. of lines and max. rated loads (tons) | | | | | | | |
|--------------------|-------------|----------------|--|------|------|------|------|------|------|-------|
| | | | 1 | 2 | 3 | 4 | 5 | 6 | 7 | 8 |
| 100-ton | 1,730 | 4 | - | - | - | 50.0 | 62.5 | 75.0 | 87.5 | 100.0 |
| 50-ton | 850 | 3 | - | 25.0 | 37.5 | 50.0 | - | - | - | - |
| 35-ton | 700 | 1 | - | 25.0 | 35.0 | - | - | - | - | - |
| 13.5-ton ball hook | 450 | 0 | 13.5 | - | - | - | - | - | - | - |

Symbols for Attachments:



Crane Boom

Auxiliary Sheave
for Crane Boom

UMAR
SALE & RENTAL

WORKING RANGES AND LIFTING CAPACITIES

Crane Boom Working Ranges

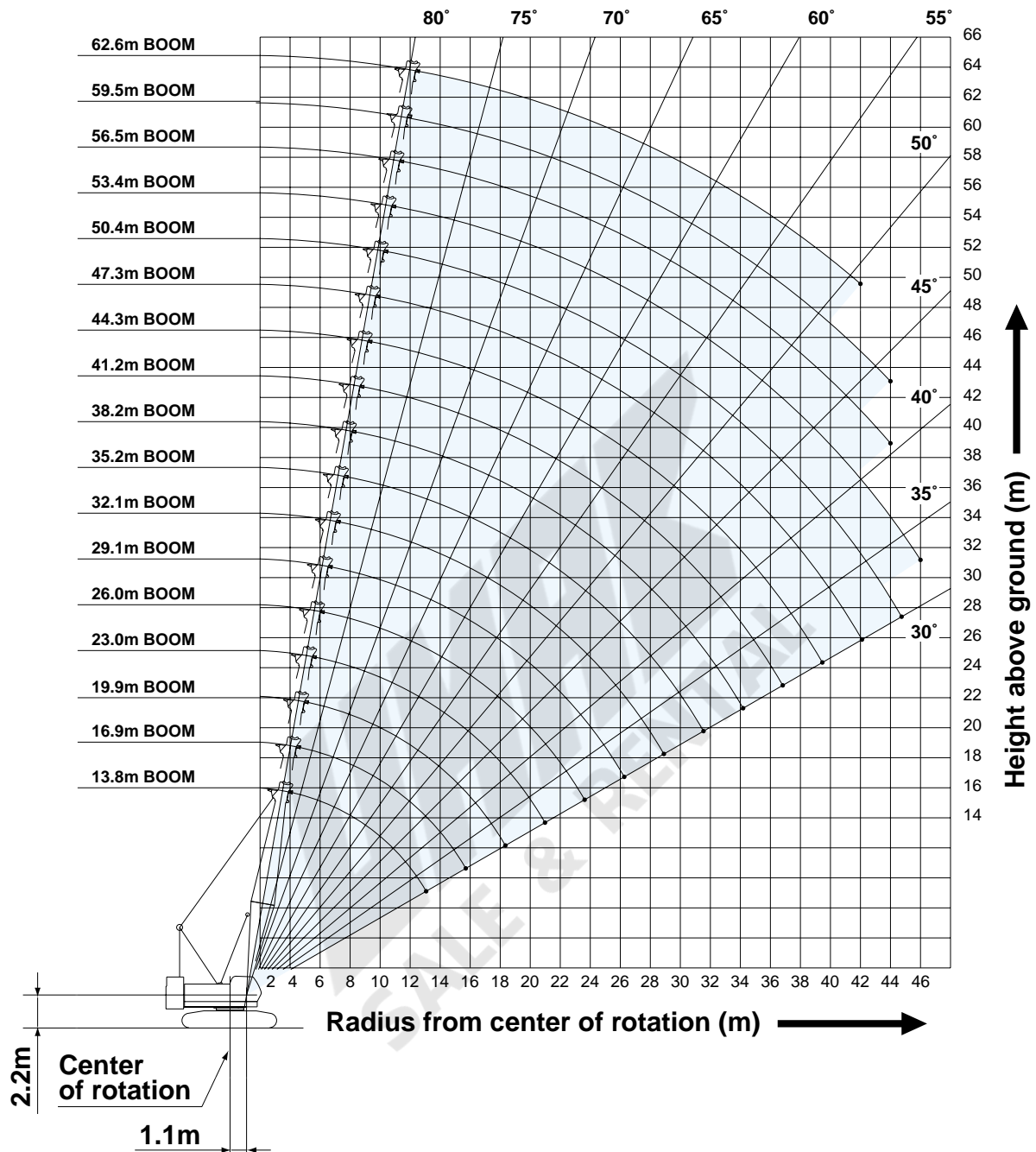

NOTES:

- Ratings according to Japanese Construction Codes for Mobile Cranes and Japanese Safety Ordinance on Cranes, etc.
- Ratings in metric tons for 360° working area.
- Operating radius is the horizontal distance from center of rotation to a vertical line through the center of gravity of the load.
- Weight of hook block(s), slings and other load handling accessories is included in rated load. Their total weight must be subtracted from rated load to obtain weight that can be lifted.
- Ratings shown are based on freely suspended loads and make no allowance for such factors as wind effect on lifted load, ground conditions, out-of-level, operating speeds or any other condition that could be detrimental to the safe operation of this equipment. Operator, therefore, has the responsibility to judge the existing conditions and reduce lifted loads and operating speeds accordingly.
- Ratings are for operation on a firm and level surface.
- At radii and boom lengths where no ratings are shown on chart, operation is not intended nor approved.
- Boom inserts and guy lines must be arranged as shown in the "Operator's Manual".
- Boom hoist reeving is 10 part line.
- Gantry must be in raised position for all conditions.
- Boom backstops are required for all boom lengths.
- Crawler frames must be fully extended for all crane operations.
- Ratings shown in are determined by the strength of the boom or other structural component.
- Instruction in the "Operator's Manual" must be strictly observed when operating the machine.
- Crane boom ratings: Deduct weight of main hook block, slings, and all other load handling accessories from crane boom ratings shown.
- Auxiliary sheave ratings for crane boom: Deduct weight of ball hook, slings, and all other load handling accessories from auxiliary sheave ratings for crane boom shown.
- Crane boom lengths for auxiliary sheave mounting are 13.8 m to 59.5 m.



Crane Boom Lifting Capacity

Unit: metric ton

Counterweight: 37.8 t, Carbody weight: 6.8 t, Crawler weight: 3.2 t

| Working radius (m) | Boom Length (m) | | | | | | | | | | | | | Working radius (m) | |
|--------------------|-----------------|------------|------------|------------|-----------|-----------|-----------|-----------|-----------|-----------|-----------|-----------|------------|--------------------|--------|
| | 13.8 | 16.9 | 19.9 | 23.0 | 26.0 | 29.1 | 32.1 | 35.2 | 38.2 | 41.2 | 44.3 | 47.3 | 50.4 | | |
| 3.8 | 100.0 | | | | | | | | | | | | | | 3.8 |
| 4.3 | 90.0 | 87.5 | 4.8m/78.0 | | | | | | | | | | | | 4.3 |
| 5.0 | 74.0 | 74.0 | 73.5 | 5.4m/70.0 | 5.9m/61.5 | | | | | | | | | | 5.0 |
| 6.0 | 61.5 | 61.5 | 61.5 | 61.5 | 61.5 | 6.4m/56.8 | | | | | | | | | 6.0 |
| 7.0 | 51.3 | 51.1 | 51.0 | 50.9 | 50.8 | 50.8 | 50.0 | 7.5m/45.0 | | | | | | | 7.0 |
| 8.0 | 42.4 | 42.2 | 42.1 | 42.0 | 41.9 | 41.8 | 41.8 | 41.7 | 41.3 | 8.5m/37.5 | | | | | 8.0 |
| 9.0 | 36.0 | 35.9 | 35.7 | 35.6 | 35.5 | 35.5 | 35.4 | 35.3 | 35.2 | 35.1 | 9.1m/34.6 | 9.6m/31.8 | | | 9.0 |
| 10.0 | 31.3 | 31.1 | 31.0 | 30.9 | 30.8 | 30.7 | 30.6 | 30.5 | 30.4 | 30.3 | 30.2 | 30.1 | 10.1m/25.0 | | 10.0 |
| 12.0 | 22.0 | 24.5 | 24.3 | 24.2 | 24.1 | 24.0 | 24.0 | 23.8 | 23.7 | 23.6 | 23.5 | 23.4 | 23.3 | | 12.0 |
| 14.0 | 13.2m/18.7 | 20.1 | 19.9 | 19.8 | 19.7 | 19.6 | 19.5 | 19.4 | 19.2 | 19.2 | 19.0 | 18.9 | 18.9 | | 14.0 |
| 16.0 | | 15.8m/14.9 | 16.8 | 16.7 | 16.5 | 16.5 | 16.4 | 16.2 | 16.1 | 16.0 | 15.9 | 15.7 | 15.7 | | 16.0 |
| 18.0 | | | 13.6 | 14.3 | 14.2 | 14.1 | 14.0 | 13.8 | 13.7 | 13.7 | 13.5 | 13.4 | 13.3 | | 18.0 |
| 20.0 | | | 18.5m/12.5 | 12.5 | 12.4 | 12.3 | 12.2 | 12.0 | 11.9 | 11.8 | 11.6 | 11.5 | 11.5 | | 20.0 |
| 22.0 | | | | 21.1m/11.1 | 10.9 | 10.8 | 10.7 | 10.5 | 10.4 | 10.3 | 10.2 | 10.0 | 10.0 | | 22.0 |
| 24.0 | | | | | 23.8m/9.8 | 9.6 | 9.5 | 9.3 | 9.2 | 9.1 | 9.0 | 8.8 | 8.8 | | 24.0 |
| 26.0 | | | | | | 8.7 | 8.5 | 8.3 | 8.2 | 8.1 | 8.0 | 7.8 | 7.8 | | 26.0 |
| 28.0 | | | | | | 26.4m/8.2 | 7.7 | 7.5 | 7.4 | 7.3 | 7.1 | 7.0 | 6.9 | | 28.0 |
| 30.0 | | | | | | | 29.0m/7.3 | 6.8 | 6.7 | 6.6 | 6.4 | 6.3 | 6.2 | | 30.0 |
| 32.0 | | | | | | | | 31.7m/6.3 | 6.1 | 6.0 | 5.8 | 5.6 | 5.6 | | 32.0 |
| 34.0 | | | | | | | | | 5.5 | 5.4 | 5.2 | 5.1 | 5.0 | | 34.0 |
| 36.0 | | | | | | | | | 34.3m/5.5 | 4.9 | 4.8 | 4.6 | 4.5 | | 36.0 |
| 38.0 | | | | | | | | | | 37.0m/4.7 | 4.3 | 4.2 | 4.1 | | 38.0 |
| 40.0 | | | | | | | | | | | 39.6m/4.0 | 3.8 | 3.7 | | 40.0 |
| 42.0 | | | | | | | | | | | | 3.5 | 3.4 | | 42.0 |
| 44.0 | | | | | | | | | | | | 42.2m/3.5 | 3.1 | | 44.0 |
| 46.0 | | | | | | | | | | | | | 44.9m/3.0 | | 46.0 |
| Reeves | 8 | 7 | 7 | 6 | 5 | 5 | 4 | 4 | 4 | 3 | 3 | 3 | 2 | | Reeves |

| Working radius (m) | Boom Length (m) | | | | Working radius (m) |
|--------------------|-----------------|------------|------------|------------|--------------------|
| | 53.4 | 56.5 | 59.5 | 62.6 | |
| 10.0 | 10.7m/25.0 | 11.2m/21.6 | 11.7m/20.1 | | 10.0 |
| 12.0 | 23.2 | 19.5 | 19.4 | 12.2m/18.0 | 12.0 |
| 14.0 | 18.7 | 18.6 | 18.0 | 15.4 | 14.0 |
| 16.0 | 15.5 | 15.4 | 15.0 | 14.5 | 16.0 |
| 18.0 | 13.2 | 13.0 | 12.9 | 12.7 | 18.0 |
| 20.0 | 11.3 | 11.2 | 11.0 | 10.9 | 20.0 |
| 22.0 | 9.8 | 9.7 | 9.6 | 9.4 | 22.0 |
| 24.0 | 8.6 | 8.5 | 8.4 | 8.2 | 24.0 |
| 26.0 | 7.6 | 7.5 | 7.3 | 7.2 | 26.0 |
| 28.0 | 6.8 | 6.6 | 6.5 | 6.3 | 28.0 |
| 30.0 | 6.0 | 5.9 | 5.8 | 5.6 | 30.0 |
| 32.0 | 5.4 | 5.3 | 5.1 | 5.0 | 32.0 |
| 34.0 | 4.8 | 4.7 | 4.6 | 4.4 | 34.0 |
| 36.0 | 4.4 | 4.2 | 4.1 | 3.9 | 36.0 |
| 38.0 | 3.9 | 3.8 | 3.7 | 3.5 | 38.0 |
| 40.0 | 3.6 | 3.4 | 3.3 | 3.0 | 40.0 |
| 42.0 | 3.2 | 3.0 | 2.9 | 2.6 | 42.0 |
| 44.0 | 2.9 | 2.7 | 2.5 | | 44.0 |
| 46.0 | 2.5 | | | | 46.0 |
| Reeves | 2 | 2 | 2 | 2 | Reeves |

Note:
 Ratings according to Japanese Construction Codes for Mobile Cranes and Japanese Safety Ordinance on Cranes, etc.
 Ratings shown in are determined by the strength of the boom or other structural components.
 Refer to notes P8.



TRAVELING CRANE MACHINE FOR FOUNDATION WORK BM1000 HD

Auxiliary Sheave Lifting Capacity for Crane Boom (With 35 t Main Hook)

Unit: metric ton

Counterweight: 37.8 t, Carbody weight: 6.8 t, Crawler weight: 3.2 t

| Working radius (m) | Boom Length (m) | | | | | | | | | | | | Working radius (m) |
|--------------------|-----------------|------------|------------|------------|-----------|-----------|-----------|-----------|-----------|-----------|-----------|------------|--------------------|
| | 13.8 | 16.9 | 19.9 | 23.0 | 26.0 | 29.1 | 32.1 | 35.2 | 38.2 | 41.2 | 44.3 | 47.3 | |
| 5.0 | 5.2m/13.5 | 5.2m/13.5 | 5.7m/13.5 | | | | | | | | | | 5.0 |
| 6.0 | 13.5 | 13.5 | 13.5 | 6.3m/13.5 | 6.8m/13.5 | | | | | | | | 6.0 |
| 7.0 | 13.5 | 13.5 | 13.5 | 13.5 | 13.5 | 7.3m/13.5 | 7.9m/13.5 | | | | | | 7.0 |
| 8.0 | 13.5 | 13.5 | 13.5 | 13.5 | 13.5 | 13.5 | 13.5 | 8.4m/13.5 | 8.9m/13.5 | | | | 8.0 |
| 9.0 | 13.5 | 13.5 | 13.5 | 13.5 | 13.5 | 13.5 | 13.5 | 13.5 | 13.5 | 9.4m/13.5 | | | 9.0 |
| 10.0 | 13.5 | 13.5 | 13.5 | 13.5 | 13.5 | 13.5 | 13.5 | 13.5 | 13.5 | 13.5 | 13.5 | 10.5m/13.5 | 10.0 |
| 12.0 | 13.5 | 13.5 | 13.5 | 13.5 | 13.5 | 13.5 | 13.5 | 13.5 | 13.5 | 13.5 | 13.5 | 13.5 | 12.0 |
| 14.0 | 13.5 | 13.5 | 13.5 | 13.5 | 13.5 | 13.5 | 13.5 | 13.5 | 13.5 | 13.5 | 13.5 | 13.5 | 14.0 |
| 16.0 | 14.6m/12.5 | 13.5 | 13.5 | 13.5 | 13.5 | 13.5 | 13.5 | 13.5 | 13.5 | 13.5 | 13.5 | 13.5 | 16.0 |
| 18.0 | | 17.2m/12.5 | 12.5 | 13.2 | 13.1 | 13.0 | 12.9 | 12.7 | 12.6 | 12.6 | 12.4 | 12.3 | 18.0 |
| 20.0 | | | 19.9m/11.4 | 11.4 | 11.3 | 11.2 | 11.1 | 10.9 | 10.8 | 10.7 | 10.5 | 10.4 | 20.0 |
| 22.0 | | | | 10.3 | 9.8 | 9.7 | 9.6 | 9.4 | 9.3 | 9.2 | 9.1 | 8.9 | 22.0 |
| 24.0 | | | | 22.5m/10.0 | 8.3 | 8.5 | 8.4 | 8.2 | 8.1 | 8.0 | 7.9 | 7.7 | 24.0 |
| 26.0 | | | | | 25.2m/7.4 | 7.5 | 7.4 | 7.2 | 7.1 | 7.0 | 6.9 | 6.7 | 26.0 |
| 28.0 | | | | | | 27.8m/6.6 | 6.6 | 6.4 | 6.3 | 6.2 | 6.0 | 5.9 | 28.0 |
| 30.0 | | | | | | | 5.8 | 5.7 | 5.6 | 5.5 | 5.3 | 5.2 | 30.0 |
| 32.0 | | | | | | | 30.4m/5.6 | 5.0 | 5.0 | 4.9 | 4.7 | 4.5 | 32.0 |
| 34.0 | | | | | | | | 33.1m/4.6 | 4.4 | 4.3 | 4.1 | 4.0 | 34.0 |
| 36.0 | | | | | | | | | 35.7m/3.9 | 3.8 | 3.7 | 3.5 | 36.0 |
| 38.0 | | | | | | | | | | 3.3 | 3.2 | 3.1 | 38.0 |
| 40.0 | | | | | | | | | | 38.4m/3.2 | 2.7 | 2.7 | 40.0 |
| 42.0 | | | | | | | | | | | 41.0m/2.5 | 2.4 | 42.0 |
| 44.0 | | | | | | | | | | | | 2.2 | 44.0 |
| Reeves | 1 | 1 | 1 | 1 | 1 | 1 | 1 | 1 | 1 | 1 | 1 | 1 | Reeves |

| Working radius (m) | Boom Length (m) | | | | Working radius (m) |
|--------------------|-----------------|------------|------------|------------|--------------------|
| | 50.4 | 53.4 | 56.5 | 59.5 | |
| 10.0 | 11.0m/13.5 | 11.5m/13.5 | | | 10.0 |
| 12.0 | 13.5 | 13.5 | 12.1m/13.5 | 12.6m/13.5 | 12.0 |
| 14.0 | 13.5 | 13.5 | 13.5 | 13.5 | 14.0 |
| 16.0 | 13.5 | 13.5 | 13.5 | 13.5 | 16.0 |
| 18.0 | 12.2 | 12.1 | 11.9 | 11.8 | 18.0 |
| 20.0 | 10.4 | 10.2 | 10.1 | 9.9 | 20.0 |
| 22.0 | 8.9 | 8.7 | 8.6 | 8.5 | 22.0 |
| 24.0 | 7.7 | 7.5 | 7.4 | 7.3 | 24.0 |
| 26.0 | 6.7 | 6.5 | 6.4 | 6.2 | 26.0 |
| 28.0 | 5.8 | 5.7 | 5.5 | 5.4 | 28.0 |
| 30.0 | 5.1 | 4.9 | 4.8 | 4.7 | 30.0 |
| 32.0 | 4.5 | 4.3 | 4.2 | 4.0 | 32.0 |
| 34.0 | 3.9 | 3.7 | 3.6 | 3.5 | 34.0 |
| 36.0 | 3.4 | 3.3 | 3.1 | 3.0 | 36.0 |
| 38.0 | 3.0 | 2.8 | 2.7 | 2.6 | 38.0 |
| 40.0 | 2.6 | 2.5 | 2.3 | 2.2 | 40.0 |
| 42.0 | 2.3 | 2.1 | 1.9 | | 42.0 |
| 44.0 | 2.0 | | | | 44.0 |
| Reeves | 1 | 1 | 1 | 1 | Reeves |

Note:

Ratings according to Japanese Construction Codes for Mobile Cranes and Japanese Safety Ordinance on Cranes, etc.

Ratings shown in are determined by the strength of the boom or other structural components.

Refer to notes P8.

CLAMSHELL

Working Ranges

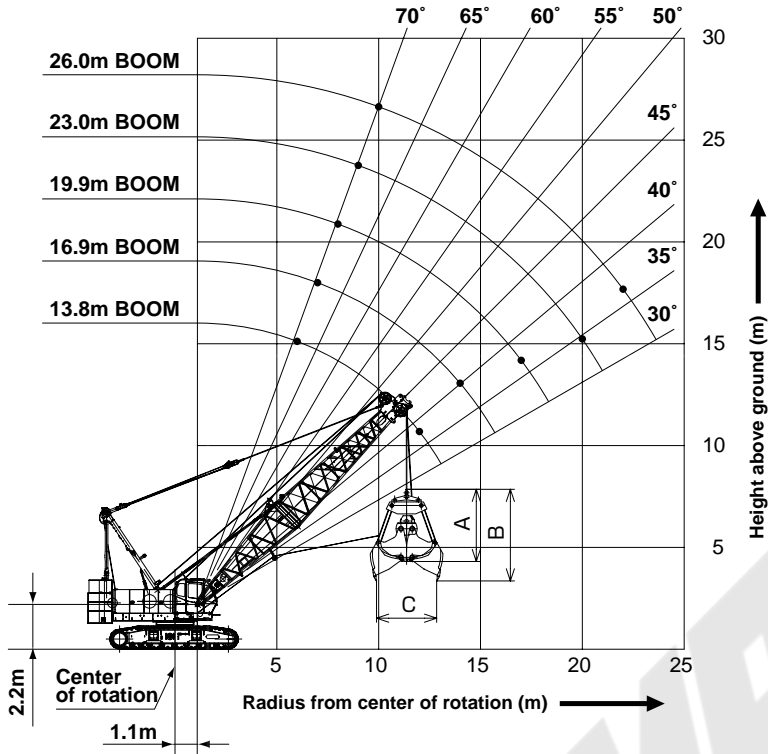

Clamshell Bucket Lifting Capacity

Unit: metric ton

Counterweight: 37.8 t

| Working radius (m) \ Boom Length (m) | 13.8 | 16.9 | 19.9 | 23.0 | 26.0 | Boom Length (m) \ Working radius (m) |
|--------------------------------------|------|------|------|------|------|--------------------------------------|
| 6.0 | 12.5 | | | | | 6.0 |
| 7.0 | 12.5 | 12.5 | | | | 7.0 |
| 8.0 | 12.5 | 12.5 | 12.5 | | | 8.0 |
| 9.0 | 12.5 | 12.5 | 12.5 | 11.4 | | 9.0 |
| 10.0 | 12.5 | 12.5 | 12.5 | 11.4 | 9.4 | 10.0 |
| 11.0 | 12.5 | 12.5 | 12.5 | 11.4 | 9.4 | 11.0 |
| 12.0 | 12.5 | 12.5 | 12.5 | 11.4 | 9.4 | 12.0 |
| 13.0 | | 12.5 | 12.5 | 11.4 | 9.3 | 13.0 |
| 14.0 | | 12.2 | 12.2 | 11.4 | 9.3 | 14.0 |
| 15.0 | | | 11.5 | 11.4 | 9.3 | 15.0 |
| 16.0 | | | 10.7 | 10.7 | 9.1 | 16.0 |
| 17.0 | | | 9.9 | 10.1 | 8.8 | 17.0 |
| 18.0 | | | | 9.5 | 8.6 | 18.0 |
| 19.0 | | | | 8.8 | 8.3 | 19.0 |
| 20.0 | | | | 8.2 | 8.1 | 20.0 |
| 21.0 | | | | | 7.8 | 21.0 |
| 22.0 | | | | | 7.3 | 22.0 |

Clamshell Bucket Specification (For Reference only)

| Bucket Capacity (m³) | Bucket Weight (t) | Dimension (m) | | | Use |
|----------------------|-------------------|---------------|-----|-----|---------|
| | | A | B | C | |
| 2.0 | 4.5 | 3.7 | 4.5 | 3.2 | Digging |
| 2.5 | 5.0 | 3.4 | 4.2 | 3.6 | Digging |
| 3.0 | 6.0 | 3.6 | 4.6 | 3.7 | Digging |

Note:

- Working radius is the horizontal distance between the center of rotation and the bucket's center of gravity.
- Total weight of bucket and materials must not exceed rated load.
- Optimal bucket should be required according to material.
 $\text{Bucket capacity (m}^3\text{)} \times \text{Specified gravity of material (ton/m}^3\text{)} + \text{Bucket weight (ton)} = \text{Rated load}$
 Material: sand, gravel, lime (apparent specific gravity: approx. 1 to 1.8)
 Ex.) Bucket capacity: 3.0 m³, Bucket weight 6.0 tons
 $3.0 \text{ m}^3 \times 1.8 + 6.0 \text{ tons} = 11.4 \text{ tons}$
- Bucket weight must also be decreased according to operating cycle and bucket lowering height.
- Rated loads are determined by stability and boom strength. During simultaneous operations of boom and swing, rapid acceleration or deceleration must be avoided. Particular case is required with long boom length.

PARTS AND ATTACHMENTS

TRAVELING CRANE BASE MACHINE FOR FOUNDATION WORK BM1000 HD

Dimensions: mm Weight: kg

Base Machine

With main and aux. winch with wire rope
Weight: 56,100 kg Width: 3,500 mm

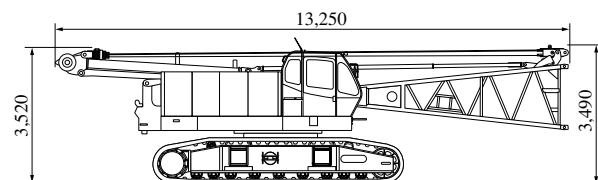

Base Machine

With main and aux. winch with wire rope
Weight: 35,700 kg Width: 3,200 mm

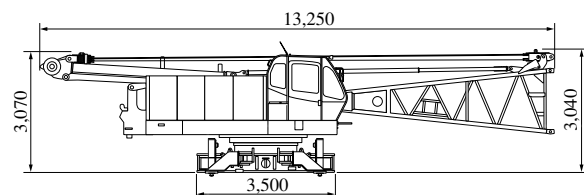

Crawler

Weight: 10,200 kg

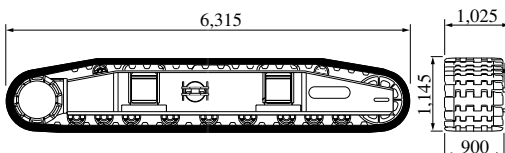

Gantry

Weight: 1,400 kg

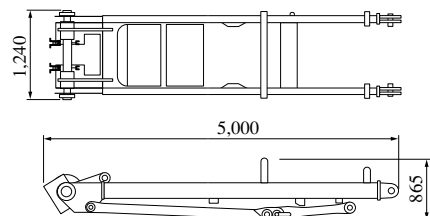

Counterweight A

Weight: 10,000 kg

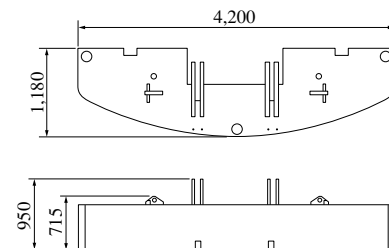

Counterweight D

Weight: 3,800 kg

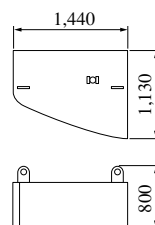

Counterweight B, C

Weight: : 7,500 kg

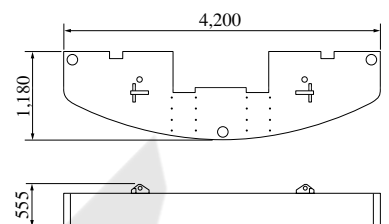

Counterweight E

Weight: 4,000 kg

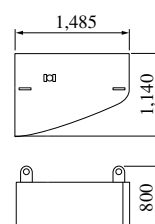

Counterweight F

Weight: 2,430 kg

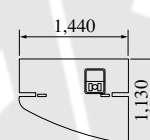

Counterweight G

Weight: 2,570 kg

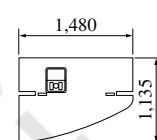

Carbody Weight

Weight: 3,400 kg x 2 pieces

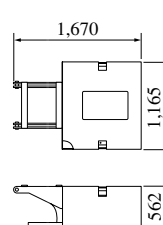

Crawler Weight

Weight: 800 kg x 4 pieces

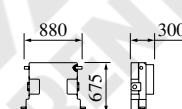

Boom Base

Weight: 1,580 kg

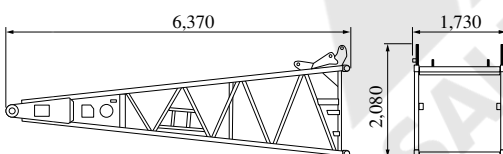

Boom Top

Weight: 1,800 kg (with boom guy cables)

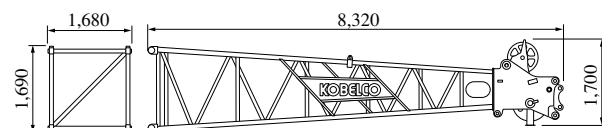

Insert Boom

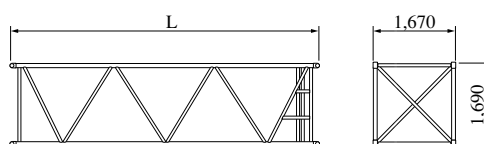

| | L (mm) | Weight (kg)* |
|------|--------|--------------|
| 3.0m | 3,170 | 500 |
| 6.1m | 6,210 | 800 |
| 9.1m | 9,260 | 1100 |

*with boom guy cables

Other Attachments

| Attachments | Weight | Dimensions (L x W x H) |
|----------------|------------------|----------------------------|
| Trans-lifter | 350 kg (1 piece) | 1,180 mm x 320 mm x 960 mm |
| Crane backstop | 130 kg (1 piece) | 4,900 mm x 145 mm dia. |
| Upper spreader | 300 kg | 1,780 mm x 305 mm x 800 mm |
| Lower spreader | 200 kg | 905 mm x 255 mm x 710 mm |
| 100-ton hook | 1,730 kg | 700 mm x 540 mm x 2,140 mm |
| 50-ton hook | 850 kg | 700 mm x 430 mm x 1,680 mm |
| 35-ton hook | 700 kg | 700 mm x 470 mm x 1,575 mm |
| Ball hook | 450 kg | 380 mm dia x 1,200 mm |

Note: Estimated weights may vary ± 2%.



**HEAVY DUTY BASE MACHINE
FOR FOUNDATION WORK**

BM1000 HD

Standard Equipment

Upper Structure/Lower Structure

Counterweight: 37.8 ton (total weight)
 Carbody weight: 6.8 ton (total weight)
 Crawler weight: 3.2 ton (total weight)
 900 mm shoe crawlers
 Batteries (136 Ah/5 HR)
 Trans-lifter (jack system)
 Gantry raising/lowering cylinder
 Electric hand throttle grip
 Variable boom hoist speed controller
 Variable main/aux. hoist speed controller
 Side deck for cab
 Steps (crawlers)
 Two front working lights
 Two rear view mirrors
 Tools (for routine maintenance)
 Upper spreader storage guide

Cab Control

Air conditioner
 Luggage box
 Cup holder
 Ashtray
 Cigar lighter
 Intermittent wiper & window washer (skylight and front window)
 Sun visor
 Roof blind
 Floor mat (cloth)
 Foot rest
 Shoe tray

Safety Device

Load Moment Indicator (with boom lowering slow stop function)
 LMI release key (for hook over-hoist prevention device and boom over-hoist prevention device)
 LCD multi display
 Ultimate stop function for boom over-hoist
 Function lock lever
 Propel lever lock
 Mechanical drum lock pawl (main, aux. and boom hoist)
 Signal horn
 Swing parking brake
 Mechanical swing lock pin (four positions)
 Swing flashers/warning buzzer

Note: Standard equipment may vary depending on your areas or countries.
 Due to our policy of continual product improvements all designs and specifications are subject to change without advance notice.
 Copyright by KOBELCO CRANES CO., LTD. No part of this catalog may be reproduced in any manner without notice.

KOBELCO CRANES CO., LTD.

17-1, Higashigotanda 2-chome, Shinagawa-ku, Tokyo 141-8626 JAPAN
 Tel: +81-3-5789-2130 Fax: +81-3-5789-3372

Inquiries To:

KOBELCO is the corporate mark used by Kobe Steel on a variety of products and in the names of a number of Kobe Steel Group companies.