

1. BASE MACHINE

1-1 Dimensions

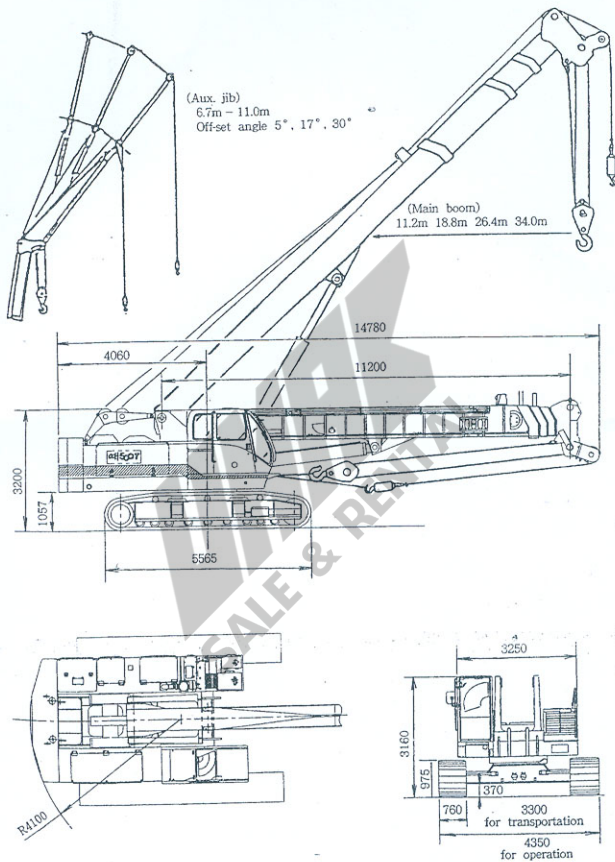

SPECIFICATIONS

2-2 Working range

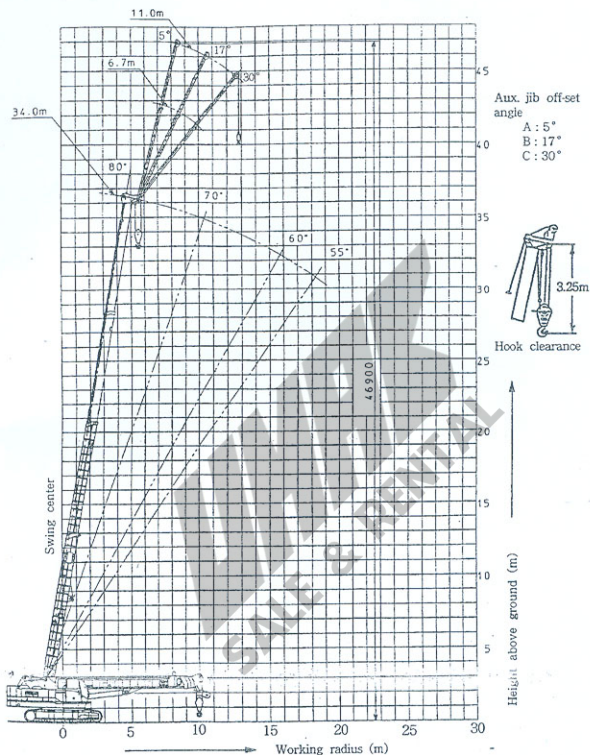

- (1) The working radius means the horizontal distance from the center of swinging to hook center.
- (2) The height above ground means the perpendicular distance from the ground to the center of the main boom point shaft (or auxiliary jib point shaft).
- (3) The hook clearance means the distance from the hook point where the hook block can be hoisted to the highest position to the boom point shaft.

SPECIFICATIONS

2-2 Working range

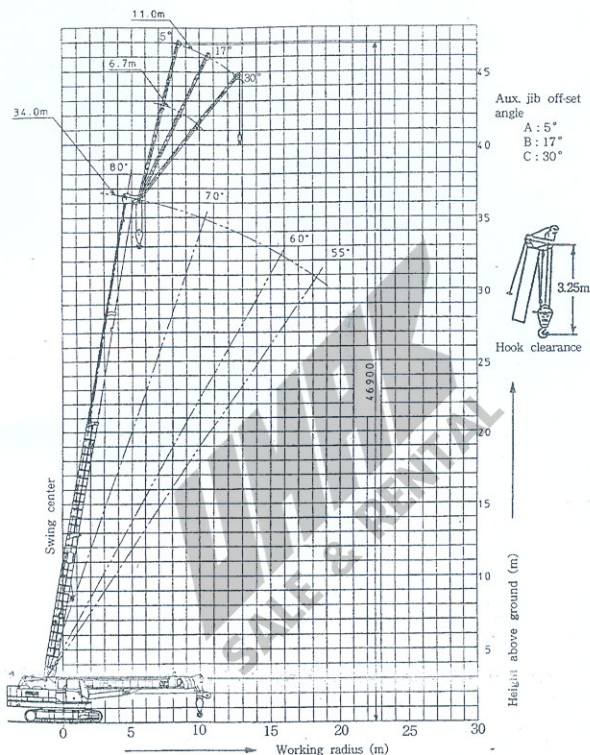

- (1) The working radius means the horizontal distance from the center of swinging to hook center.
- (2) The height above ground means the perpendicular distance from the ground to the center of the main boom point shaft (or auxiliary jib point shaft).
- (3) The hook clearance means the distance from the hook point where the hook block can be hoisted to the highest position to the boom point shaft.

SPECIFICATIONS

2. STANDARD CRANE

2-1 Major specifications

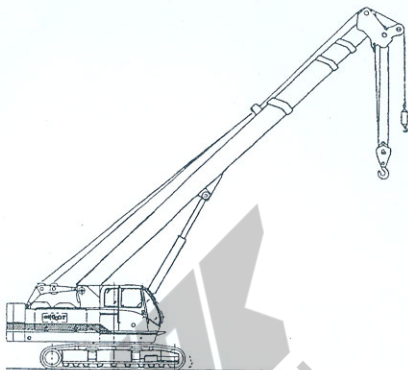

Lifting capacity	Main hoist	Max. lifting load × working radius	50t × 3.7 m (Main jib length 11.2 m)
	Aux. hoist	Max. lifting load × working radius	3t × 8.3 m
Boom length	Main boom	Basic (Retracted most)	11.2 m
		Maximum	34.0 m
	Aux. jib		6.7 m , 11 m
	Max. combination of main boom + aux. jib		
Working range	Main boom	Working radius	3.7 m ~ 28 m
	Aux. jib	Working radius	8.3 m ~ 28.8 m
	Main boom	Max. lifting height	33 m
		(Equipped with 24-m main boom)	
	Aux. jib	Max. lifting height	About 45 m
	Main boom	Boom angle	26° ~ 80°
Rope part of line	Main hoist	50-ton hook	10-part of line
	Aux. hoist	5-ton hook	1-part of line
Counterweight	7.4 ton + 7.4 ton		14.8 t
Working weight			About 55.8 t
Average grounding pressure			0.67 kg/cm ²

SPECIFICATIONS

2-3 Rated overall lifting load

When extending crawler

(Unit : tf)

Working radius (m)	Main jib length (m)			
	11.2	18.8	26.4	34.0
3.7	50.00	30.00		
4.0	43.50	30.00		
4.5	36.00	30.00	21.00	
5.0	31.50	27.00	21.00	
5.5	28.00	24.00	19.00	
6.0	25.00	21.20	17.60	9.00
7.0	20.00	17.50	15.20	9.00
8.0	16.00	14.50	13.10	9.00
9.0	13.00	12.30	11.40	9.00
10.0	9.95 m × 11.2	10.40	9.90	9.00
11.0		9.00	8.60	8.20
12.0		7.80	7.50	7.30
13.0		6.80	6.60	6.60
14.0		6.00	5.80	6.00
15.0		5.3.0	5.00	5.30
16.0		4.70	4.30	4.70
17.0		4.10	3.70	4.10
18.0		17.55 m × 3.70	3.20	3.60
19.0			2.70	3.20
20.0			2.30	2.80
22.0			1.60	2.10
24.0			1.00	1.60
26.0			25.15 m × 0.70	1.10
28.0				28.00 m × 0.80