

CCH350

IHI

Fully Hydraulic Crawler Spanner Crane

■ General dimensions (with basic boom) Unit: mm

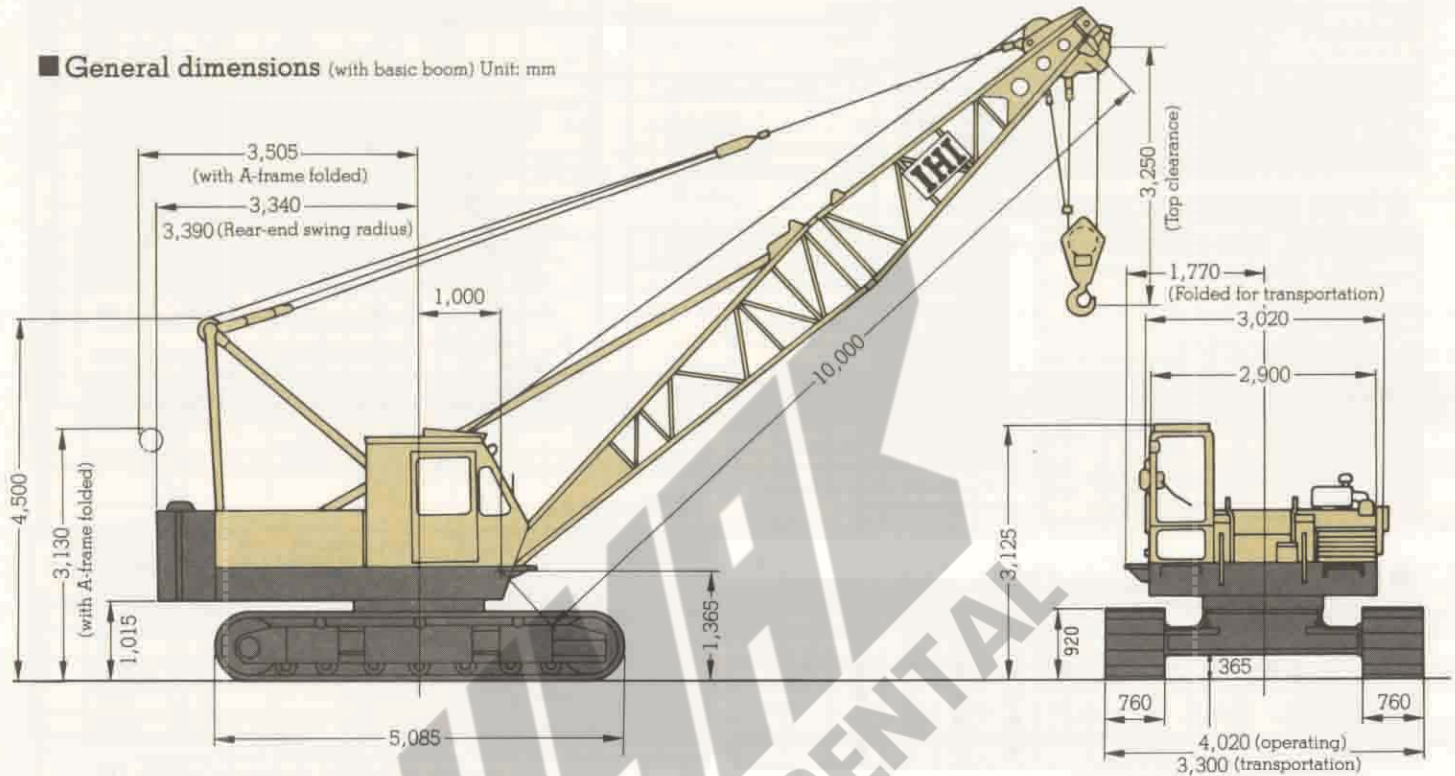

■ Specifications

Performance	
Swing speed	3.5 rpm
Travel speed	1.6km/h
Gradeability	40% (Approx. 22°) (with 10m boom and 35-ton hook block)
Operation system	
Power source	Hydraulic
Transmission system	Hydraulic
Drum type	Single shaft, dual drum
Swing system	Swing bearing
Hydraulic pump	Variable displacement axial plunger pump × 2 Gear pump × 2
Engine	
Model	Hino H06CT
Type	4-cycle, water cooled, overhead valve
Combustion chamber	Direct injection diesel
Cylinder bore stroke	6—108mm × 118mm
Total displacement	6.485ℓ
Rated output	150 PS/2,100 rpm (with turbocharger)
Max. torque	52kg•m/1,600 rpm
Rated fuel consumption rate	165g/PS•h (at rated output)
Fuel tank capacity	250ℓ

■ Safety equipment

- Counterbalance valve, Check valve, Relief valve.
- Multi-disc traction brake
- Swing lock, Swing parking brake
- Drum lock
- Boom angle indicator
- Telescopic boom limit stop
- Boom overhoisting prevention
- Hook overwinding prevention

■ Optional equipment

- Electronic moment limiter
- Third drum
- Automatic winch brakes
- Counterweight self-dismantling device
- Car cooler
- Combustion type heater
- Electric fuel pump
- Swing flasher and horn
- Flood light, Yellow rotary lamp
- Wireless helmet phone
- Electric level gauge
- Spark arrester
- Track link type flat shoe

The machine is manufactured in compliance with the Japanese Labor Ministry's "Structural Standards for Mobile Cranes," and it meets the requirements of "Safety Regulations for Crane and Related Machines".

Ishikawajima Construction Machinery Co., Ltd.

Crane

Working range

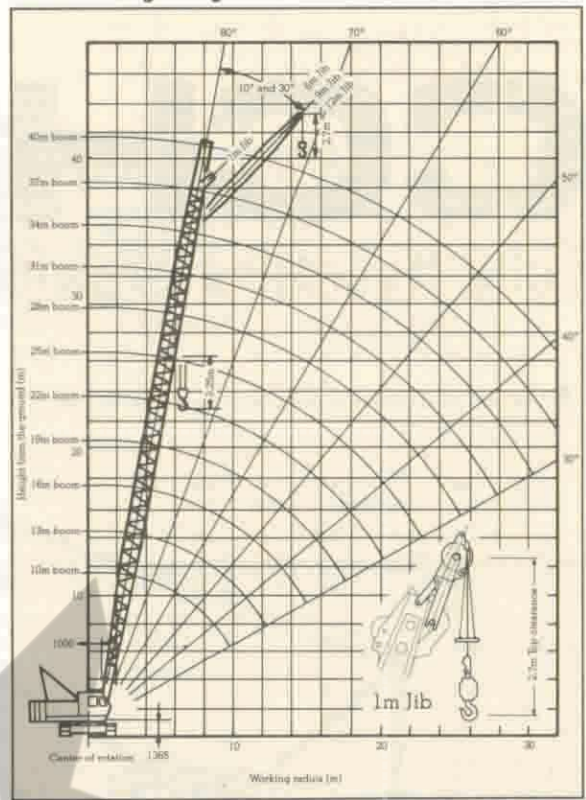

Specifications

Maximum lifting load x working radius		35 ton x 3.5m
Maximum lift above ground		37.5m (40m boom)
Rope speed	Boom hoisting and lowering	55m/min (4th layer of drum)
	Load hoisting and lowering	High speed 80m/min, Low speed 40m/min
	Jib load hoisting and lowering	High speed 80m/min, Low speed 40m/min
Part lines	Boom hoisting and lowering	12 part lines
	35 ton hook	7 part lines
	5 ton hook	1 part line
Counterweight		12 tons (7 + 5)
Crane total weight (with 10m boom and 35 ton hook block)		34.9 tons
Average ground bearing pressure		0.51 kg/cm ²

Boom composition/Jib composition (Unit: m)

Boom length	Boom composition	40	6+3+3+6+6+6+6+4
10	6 (inner) + 4 (outer)		
13	6+3+4		
16	6+3+3+4		
19	6+3+6+4		
22	6+3+3+6+4		
25	6+3+6+6+4		
28	6+3+3+6+6+4		
31	6+3+6+6+6+4		
34	6+3+3+6+6+6+4		
37	6+3+6+6+6+6+4		

Jib length	Jib composition
1	1 (auxiliary jib)
6	3 (inner) + 3 (outer)
9	3+3+3
12	3+6+3*

* When delivered with 12m jib, 6m insert boom consists of 3m x 2.

Combination of Boom and Jib (●: available combination)

Jib length (m)	Boom length (m)										
	10	13	16	19	22	25	28	31	34	37	40
1	●	●	●	●	●	●	●	●	●	●	●
6						●	●	●	●	●	●
9						●	●	●	●	●	●
12						●	●	●	●	●	●

Rated lifting loads (Throughout 360°; within 78% of tipping load; forward stability factor over 1.15)

(Unit: ton)

Working radius (m)	Boom length (m)										
	10	13	16	19	22	25	28	31	34	37	40
3.0	3.02m x 35.00										
3.5	35.00	3.34m x 34.70									
4.0	29.85	29.80	4.06m x 29.25								
4.5	25.20	25.15	25.10	4.50m x 24.50							
5.0	21.70	21.65	21.60	21.55	5.20m x 20.00	5.62m x 18.00					
6.0	16.55	16.50	16.45	16.40	16.35	16.30	6.33m x 15.00	6.66m x 13.85			
7.0	13.25	13.20	13.15	13.10	13.05	13.00	12.95	12.90	7.18m x 12.35	7.70m x 10.00	
8.0	11.05	10.95	10.90	10.85	10.80	10.75	10.70	10.65	10.55	8.28m x 10.00	8.23m x 9.95
9.0	9.40	9.35	9.25	9.20	9.15	9.10	9.05	9.00	8.90	8.85	8.75
10.0	9.80m x 8.40	8.10	8.05	8.00	7.95	7.90	7.80	7.75	7.65	7.60	7.50
12.0		6.35	6.30	6.25	6.20	6.15	6.05	6.00	5.90	5.85	5.70
14.0		12.46m x 6.10	5.10	5.05	5.00	4.95	4.85	4.80	4.70	4.65	4.55
16.0			11.00m x 4.65	4.20	4.15	4.10	4.00	3.95	3.85	3.80	3.65
18.0				17.50m x 3.70	3.50	3.45	3.35	3.30	3.20	3.15	3.00
20.0					3.00	2.95	2.85	2.80	2.70	2.65	2.50
22.0					20.18m x 2.95	2.55	2.45	2.40	2.30	2.25	2.10
24.0						24.79m x 2.40	2.10	2.05	1.95	1.90	1.75
26.0							25.38m x 1.90	1.80	1.70	1.60	1.45
28.0								27.96m x 1.55	1.40	1.35	1.20
30.0									1.20	1.10	1.00
32.0									30.58m x 1.10	0.90	0.80

● All rated loads shown are based on the machine being on a firm level, uniformly supporting surface without traveling.

● The weight of the slings, hook block (1) and auxiliary lifting devices are considered to be a part of the load. Main hook block (35 ton capacity)..... 0.35 tons Jib hook block (5 ton capacity)..... 0.12 tons

● Depending on the number of part lines rated lifting load is limited as follows.

1-part line...up to 5 tons
2-part line...up to 10 tons
3-part line...up to 15 tons
4-part line...up to 20 tons

5-part line...up to 25 tons
6-part line...up to 30 tons
7-part line...up to 35 tons

● When boom is equipped with jib, main hook ratings must be reduced the following weight.

Jib length	1m	6m	9m	12m
Weight to be reduced	0.5t	0.75t	0.95t	1.2t

● The rated loads for jib when the main hook is installed must be reduced by the total weight of the main hook and the jib hook.

● Bucket and lifting magnet operations cannot be performed by jibs.

● The rated load for jib should not exceed the values in the table below.

Jib angle	Jib boom length			
	1m	6m	9m	12m
10°	5.0 tons	4.0 tons	4.0 tons	3.5 tons
30°		4.0 tons	3.5 tons	3.0 tons

● The angle formed by the extension line of the main boom and the center line of the jib boom should not exceed 30° under load conditions.

Lifting Magnet

Specifications

Rope speed	Boom hoisting and lowering	47m/min (4th layer of drum)
	Load hoisting and lowering	High speed 68m/min, Low speed 34m/min
Part lines	Boom hoisting and lowering	12 part lines
	Load hoisting and lowering	1-7 part lines
Counterweight (exclusive for lifting magnet)		10.5 tons (5.5 + 5.0)
Total weight (13m boom + ϕ 1500 magnet)		37.8 tons
Average ground bearing pressure		0.55 kg/cm ²

Magnet specifications

Electromagnet	Diameter	ϕ 1500	ϕ 1800 (optional)
	Weight	2.7 tons	4.2 tons
Voltage		DC-220V	DC-220V
Generator capacity		16.5kW/1,800 rpm	22kW/1,800 rpm
Lifting capacity	Ingot	24 tons	30 tons
	Punch scrap	0.5-0.9 tons	0.75-1.3 tons
	Iron scrap	1.2-1.9 tons	1.65-2.8 tons
	Pig iron	1.3-1.9 tons	1.8-2.8 tons

Rated lifting capacity

With 10.5-ton (full) counterweight

Boom length (m)	Working radius (m)													
	3.5	4	4.5	5	6	7	8	9	10	12	14	16	18	
10	35.0	27.5	22.4	18.9	14.3	11.5	9.6	8.1	^{9.80m} 7.3					
13	^{3.53m} 34.6	27.4	22.4	18.9	14.3	11.5	9.5	8.1	7.0	5.5	^{12.40m} 5.3			
16		^{4.06m} 26.7	22.3	18.8	14.2	11.4	9.5	8.0	7.0	5.4	4.4	^{15.00m} 4.0		
19			^{4.58m} 21.7	18.8	14.2	11.4	9.4	8.0	6.9	5.4	4.4	3.7	^{17.60m} 3.2	

With 5.5-ton counterweight

Boom length (m)	Working radius (m)													
	3.5	4	4.5	5	6	7	8	9	10	12	14	16	18	
10	26.4	20.5	16.7	14.1	10.6	8.5	7.0	6.0	^{9.80m} 5.3					
13	^{3.53m} 25.9	20.5	16.7	14.0	10.6	8.4	7.0	5.9	5.1	3.9	^{12.40m} 3.6			
16		^{4.06m} 19.9	16.6	14.0	10.5	8.4	6.9	5.8	5.0	3.9	3.1	^{15.00m} 2.8		
19			^{4.58m} 16.1	14.0	10.5	8.4	6.9	5.8	5.0	3.9	3.1	2.5	^{17.60m} 2.2	

Lifting magnet working range

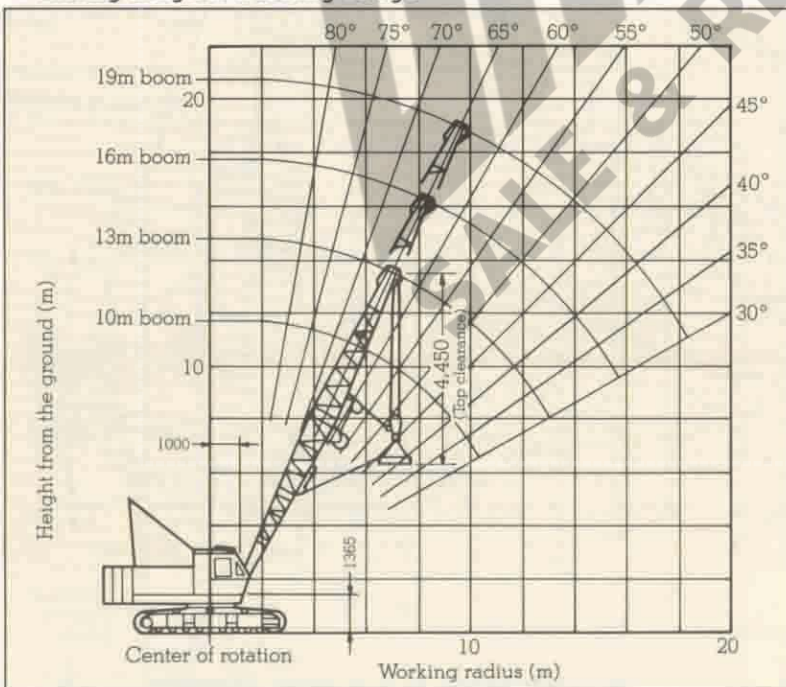

Wire rope

Place of use	Rope diameter (mm) × overall length (m)	Guaranteed strength (t)	Rope type
Lifting magnet	ϕ 20 × 110	30.0	A
Boom hoisting	ϕ 14 × 126	14.9	A
Boom suspension	ϕ 28	59.7	A
Weight type tagline	ϕ 10 × 38 (stroke 20m)	5.5	B
Weight type tagline	ϕ 10 × 56 (stroke 40m)	5.5	B
Spring type tagline	ϕ 10 × 30	5.5	B
Hydraulic type tagline	ϕ 10 × 49	5.5	B

Rope type A: 6 × F1 (29) IWRC preformed regular Z lay

B: 6 × 19 hemp core regular Z lay

● The weight of hook block, magnet and auxiliary lifting devices are considered to be a part of the load.
35 ton hook... 350kg 15 ton hook... 310kg

● Depending on the number of part lines rated lifting load is limited as follows.

1-part line... up to 5 tons 5-part line... up to 25 tons
2-part line... up to 10 tons 6-part line... up to 30 tons
3-part line... up to 15 tons 7-part line... up to 35 tons
4-part line... up to 20 tons

● Engine revolving speed is 1,800 rpm.

● For iron scrap handling, use 5.5 ton counterweight (with outer counterweight removed). Cycle time is shortened and productivity is increased. For a 15 ton hook with attachments, use a 3 part line.

● For lifting magnet specification the rear-end swing radius differs from the standard crane equipped machine. (340mm greater)

● The lifting capacity given in the above table indicates the average of lifting capacities covering the cold through hot state of the lifting magnets.

● The lifting capacity of lifting magnets varies widely with the shape, size, and stacking condition of the material to be carried.

● When conditions adverse to the lifting magnets are combined, the lifting capacity may fall below the value shown in the table.

Dragline

Specifications

Rope speed	Boom hoisting and lowering	55m/min (4th layer of drum)
	Bucket hoisting	High speed 80m/min, Low speed 40m/min
	Bucket digging	High speed 80m/min, Low speed 40m/min
Part lines	Boom hoisting and lowering	12-part lines
	Bucket hoisting	1-part line
	Bucket digging	1-part line
Counterweight	7 tons	
Total weight (13m boom + 0.8m ³ bucket)	31.4 tons	
Average ground bearing pressure	0.46 kg/cm ²	

Bucket specifications

Classification	Capacity (m ³)	Weight (t)	Purpose
Optional	0.6	0.93	General purpose digging
Standard	0.8	1.17	General purpose digging
Optional	1.0	1.40	Light duty digging, scraping
Optional	1.2	1.60	Light duty digging, scraping

Working range and hoisting capacity

Boom angle	10m			13m			16m			
	30°	40°	50°	30°	40°	50°	30°	40°	50°	
Working radius (m)	10.0	9.0	7.8	12.6	11.3	9.8	15.2	13.6	11.7	
Rated lifting load (t)	4.5	4.5	4.5	3.8	4.4	4.5	2.8	3.3	4.1	
Maximum digging distance (m)	11.9	11.4	10.6	15.0	14.3	13.3	18.1	17.3	15.9	
Maximum digging depth (m)	6.6	6.2	5.7	8.8	8.3	7.6	10.9	10.4	9.4	
Maximum dumping height (m)	0.6m ³	3.1	4.4	5.3	4.2	6.0	7.6	5.7	8.0	9.9
	0.8m ³	2.9	4.2	5.1	4.0	5.8	7.4	5.5	7.8	9.7
	1.0m ³ , 1.2m ³	2.5	3.8	4.7	3.6	5.4	7.0	5.1	7.4	9.3

- As the rated lifting load is the total weight of the bucket and selected load, the total weight should not exceed the weight figures in the above table.
- Carefully select a bucket to match the soil to be handled. For unusually hard or compact soil, do not use 1.0m³ and 1.2m³ buckets.
- Two counterweights (7 and 5 tons) are provided. For dragline work, remove the outer counterweight and use the inner counterweight (7 ton) only.
- Digging distance and digging depth vary depending on the size and type of bucket as well as working conditions. (The figures in the table are theoretical values.)

Wire rope

Place of use	Rope diameter (mm) × overall length (m)	Guaranteed strength (t)	Rope type
Hoisting	φ20 × 45	30.0	A
Dragline	φ20 × 30	29.8	B
Boom hoisting	φ14 × 126	14.9	A
Boom suspension	φ28	59.7	A
Dump	φ12.5 × 5	10.8	A

Rope type A: 6 × F1 (29) IWRC preformed regular Z lay
 B: 6 × S (19) IWRC rung lay
 Use a single sheave type at boom point.

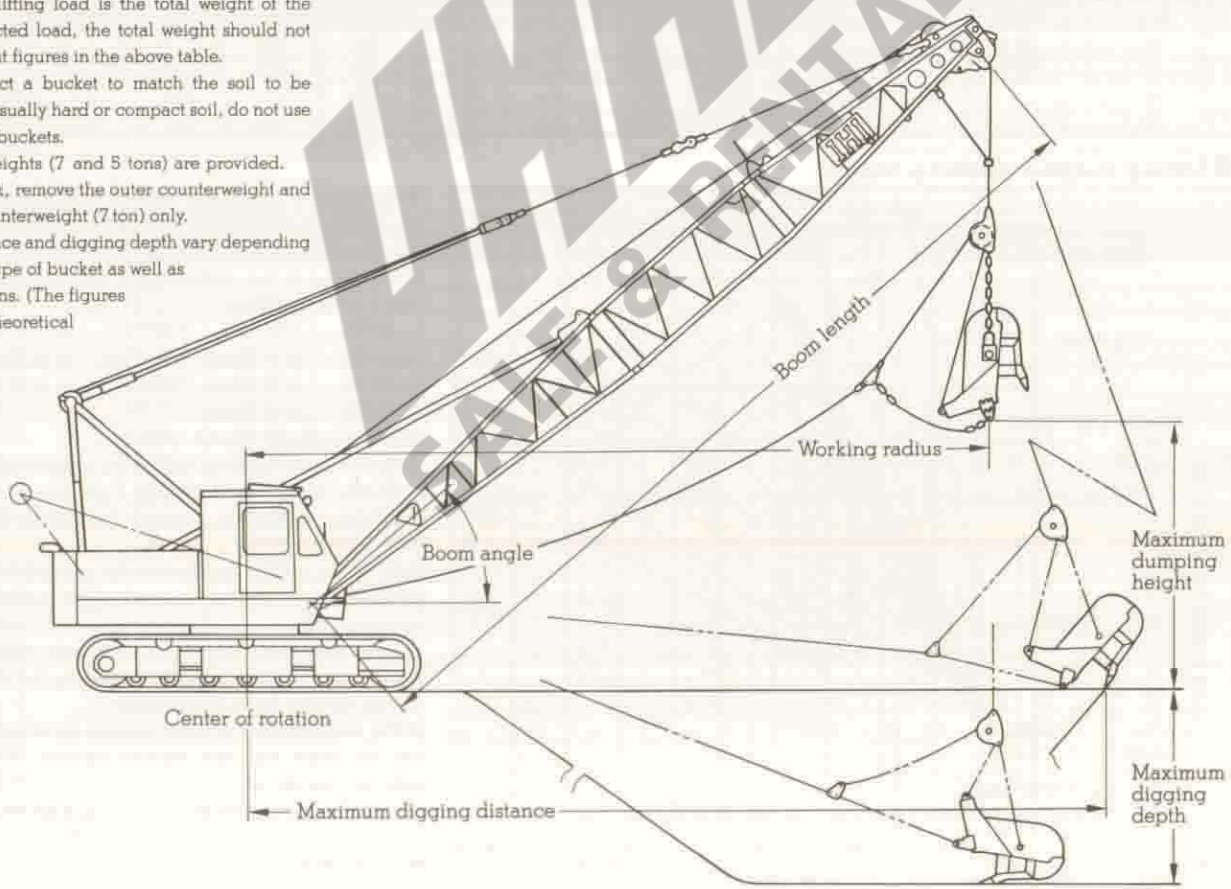

50°
40°
30°
20°
10°
0°
10°
20°
30°
40°
50°
60°
70°
80°
90°
100°
110°
120°
130°
140°
150°
160°
170°
180°
190°
200°
210°
220°
230°
240°
250°
260°
270°
280°
290°
300°
310°
320°
330°
340°
350°
360°

Clamshell

■ Specifications

Maximum lift above ground		37m (13m boom + 1.0m ³ bucket)
Rope speed	Boom hoisting and lowering	55m/min (4th layer of drum)
	Bucket opening and closing	High speed 80m/min, Low speed 40m/min
	Bucket suspension hoisting and lowering	High speed 80m/min, Low speed 40m/min
Part lines	Boom hoisting and lowering	12-part lines
	Bucket opening and closing	6-part lines (for all types of buckets)
	Bucket suspension	1-part line (for all types of buckets)
Counterweight		12 tons (7 + 5)
Total weight (13m boom + 1.0m ³ bucket)		37.7 tons
Average ground bearing pressure		0.55 kg/cm ²

■ Wire rope

Place of use	Rope diameter (mm)	Guaranteed strength (t)	Rope type	Length (m)
Bucket opening and closing	φ20	30.0	A	69 (with 19m boom)
Bucket holding	φ20	30.0	A	55 (with 19m boom)
Boom hoisting	φ14	14.9	A	126 (12 part lines)
Boom suspension (pendant)	φ28	59.7	A	5.9 (for outer boom)
				3 (for 3m insert boom)
				6 (for 6m insert boom)
Weight type tagline	φ10	5.5	B	38 (for 13m boom) 56 (longer than 16m boom) *
Spring type tagline	φ10	5.5	B	30 *
Hydraulic type tagline	φ10	5.5	B	49 *

■ Clamshell bucket specifications

Classification	Type	Capacity (m ³)	Weight (t)
Optional	HD	0.6	3.0
Optional	GP	0.8	2.1
Standard	GP	1.0	2.5
Optional	WR	1.0	2.0
Optional	WR	1.25	1.6

Bucket type (Purpose)

HD: Heavy duty (Civil engineering, construction)

GP: General purposes (Heavy load handling)

WR: Wide rehandling (Medium load rehandling)

Rope type

A: 6×F1 (29) IWRC preformed regular Z lay

B: 6×19 hemp core regular Z lay

*: optional.

■ Working range and allowable load

Boom length (m)		10				13				16				19			
Boom angle		35°	45°	55°	65°	35°	45°	55°	65°	35°	45°	55°	65°	35°	45°	55°	65°
Working radius (m)		9.5	8.4	7.1	5.7	12.0	10.6	8.9	6.9	14.4	12.7	10.6	8.2	16.9	14.8	12.3	9.5
Rated lifting load (t)	Counterweight type	12-ton type		7-ton type		12-ton type		7-ton type		12-ton type		7-ton type		12-ton type		7-ton type	
	type	5.0	5.0	5.0	5.0	5.0	5.0	5.0	5.0	4.3	5.0	5.0	5.0	3.4	4.1	5.0	5.0
Maximum dumping height (m)		1.4	2.7	3.9	4.8	3.1	4.9	6.4	7.5	4.8	7.0	8.8	10.2	6.5	9.1	11.3	13.0
Maximum digging depth (m)	Tagline type	Weight type (stroke 20m)				17				17				17			
		Weight type (stroke 40m)				—				29				27			
		Hydraulic type				36				35				33			
		Spring type				12				12				12			

■ Working range

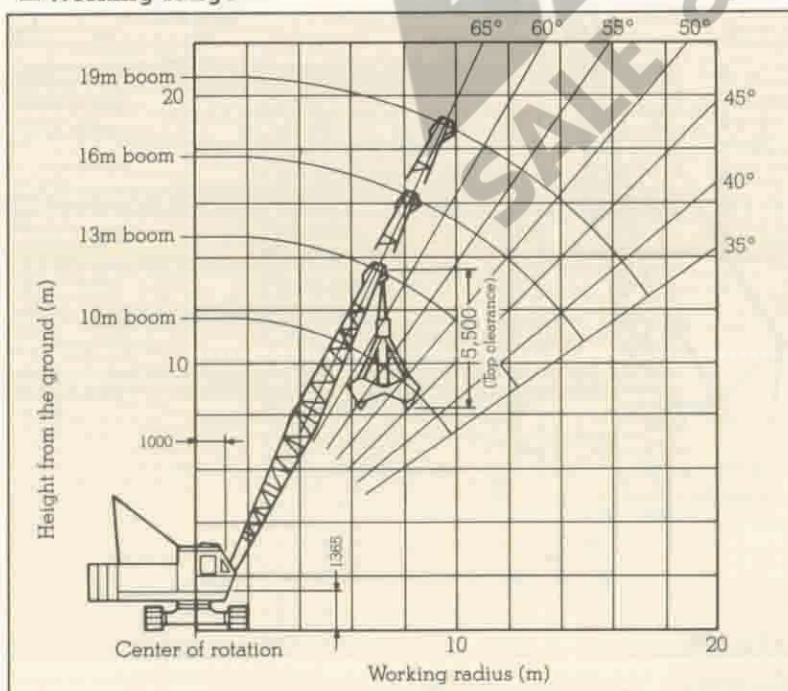

● For normal clamshell work, use 7-ton counterweight (with outer counterweight removed).

As compared to the 12-ton counterweight, swing acceleration increases improving hourly productivity.

● Rated lifting load is the upper limit of "bucket weight + load" during clamshell work.

Use a bucket suitable for the kind of the load required so that the allowable load figures in the table are not exceeded.

● The maximum dumping height is for a 1.0m³ standard bucket.

● The maximum digging depth is for the standard opening and closing wire rope length.

● By using 10m longer suspension, opening and closing wire rope, and weight type 40m stroke or hydraulic tagline, the digging depth can be increased up to the maximum digging depth of 36m.

Flying Leader

■ Specifications

Rope speed	Boom hoisting and lowering	55m/min (4th layer of drum)	
	Hammer hoisting and lowering	High speed 80m/min, Low speed 40m/min	
	Pile hoisting and lowering	High speed 80m/min, Low speed 40m/min	
Part lines	Boom hoisting and lowering	12 part lines	
	Hammer hoisting	IDH-25	2 part lines
		IDH-35	3 part lines
		IDH-45	3 part lines
	Pile hoisting	Under 5 tons	1 part line
5-10 tons		2 part lines	
Counterweight	12 tons (7 + 5)		
Possible travelling weight (on Pile driver attachment)	55 tons		
Allowable average ground bearing pressure	0.95 kg/cm ²		

■ Wire rope

Place of use	Rope diameter (mm) × overall length (m)	Guaranteed strength (t)
Boom hoisting	φ14 × 126	14.9
Boom suspension	φ28	59.7
Hammer hoisting	φ20 × 160	30.0
Pile hoisting	φ20 × 110	30.0

All the ropes are of 6 × F1 (29) IWRC preformed regular Z lay

■ Working performance R: Working radius (m) W: Pile weight (t)

Leader type	FS500									
	IDH-25		IDH-35		IDH-45		IDH-35		IDH-45	
Hammer type	IDH-25		IDH-35		IDH-45		IDH-35		IDH-45	
Hammer weight (t)	5.5		7.8		11.0		7.8		11.0	
Cap weight (t)	0.5		1.0		1.8		1.0		1.8	
Boom length (m) B	16		19		13		16		13	
Leader length (m) L	20.85		23.85		26.85		20.85		17.85	
Pile length (m) P	14		17		20		13.5		10	
Boom angle	R	W	R	W	R	W	R	W	R	W
82°	5.1	5.0	5.5	4.5	5.5	4.0	5.1	4.5	4.8	3.5
81°	5.3	5.0	5.8	4.5	5.8	4.0	5.4	4.5	5.0	3.5
80°	5.6	5.0	6.1	4.0	6.1	3.0	5.7	3.5	5.2	2.5
79°	5.9	5.0					5.9	2.0		

- Angle of pile pulling rope with leader below 10°.
- It is not possible to work in leader inclined forward.
- Pile pulling shall be effected with leader in vertical posture.
- Permissible weight for pile pulling does not exceed a range in vertical posture specified in working capacity table.

■ Boom combination

(Unit: m)

Boom length	Boom composition
10	6 (inner) + 4 (outer)
13	6+3+4
16	6+3+3+4
19	6+3+6+4

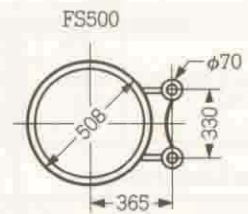
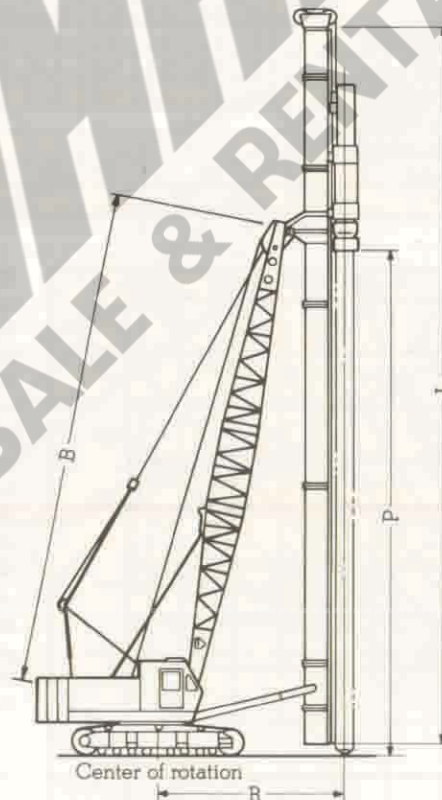

(Unit: mm)