

DEMAG

TC 2000

Lattice Boom Crane

CAPACITIES IN
U. S. MEASUREMENTS



**MANNESMANN
DEMAG**

Construction Machinery

Basic Machine

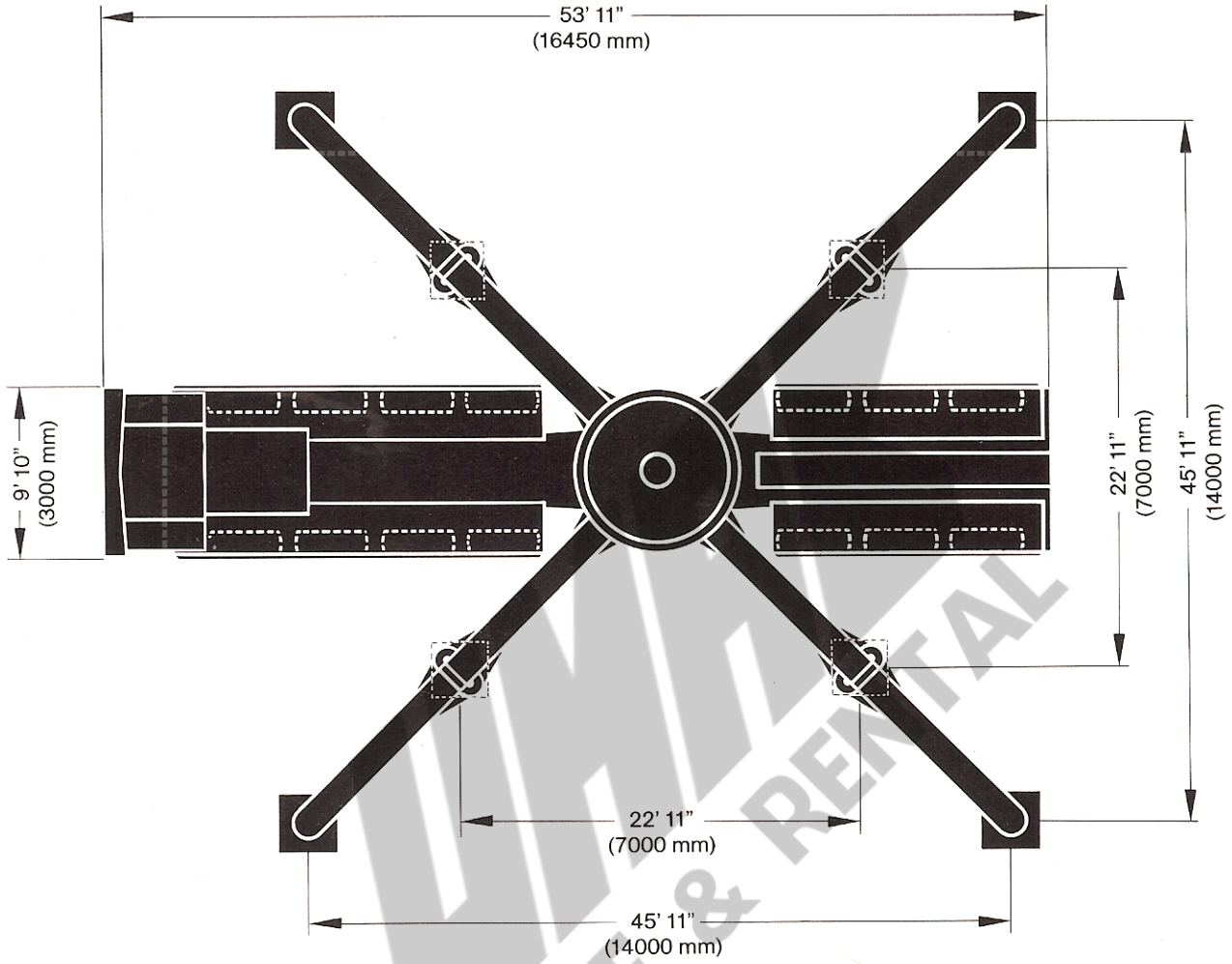
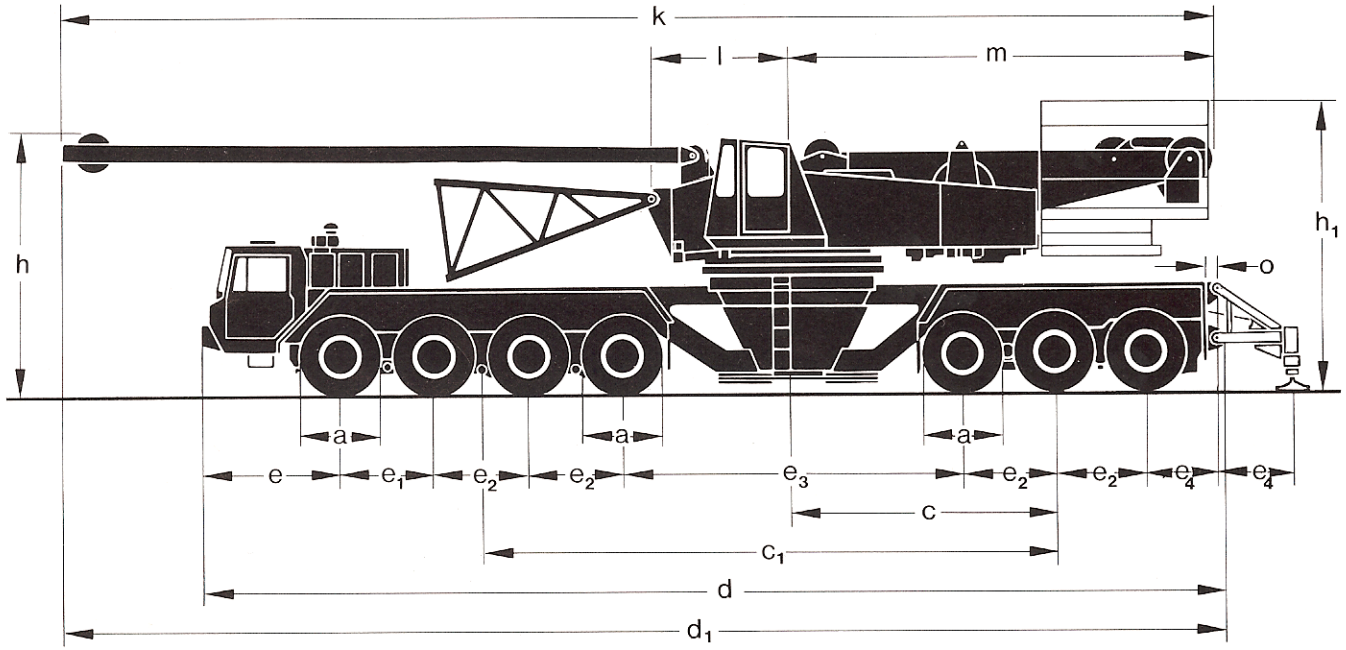

SALE & RENTAL

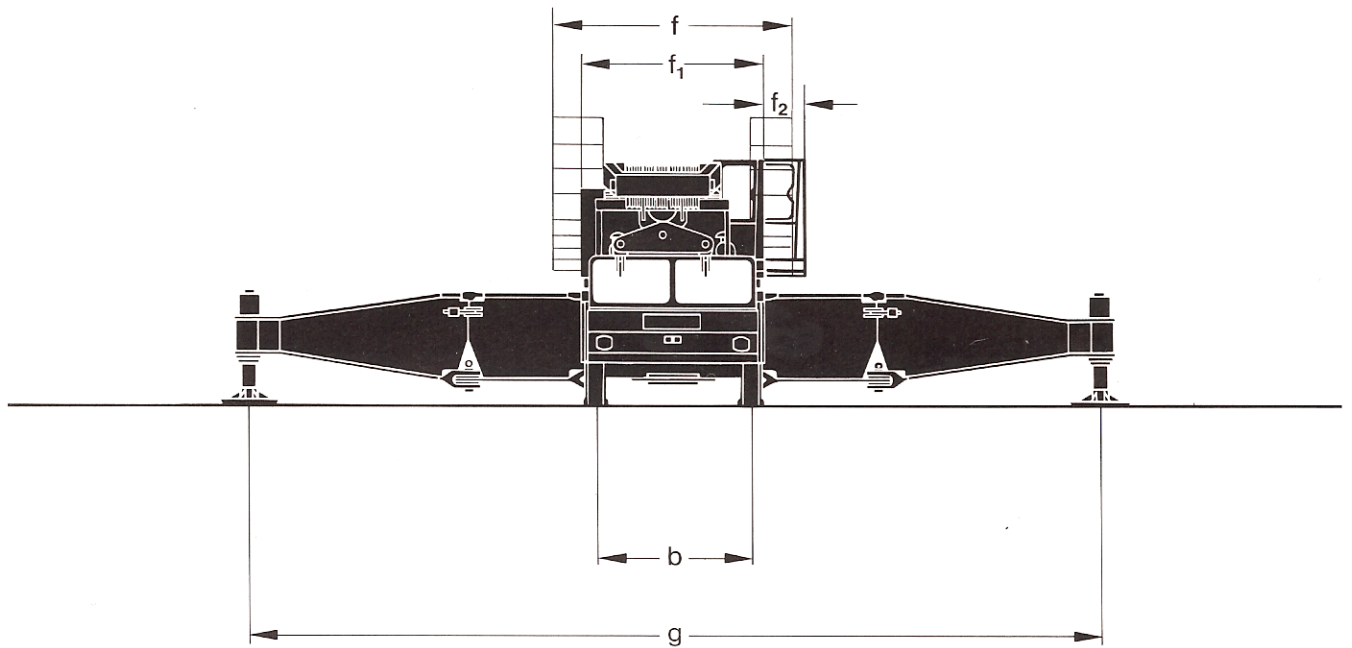

a	14.00 - 24, PR 22	d	54' 9" (16710 mm)	e ₄	3' (1150 mm)	h ₁	15' (4575 mm)
b	8' 5" (2503 mm)	d ₁	62' 2" (18950 mm)	f	15' 9" (4790 mm)	k	61' 4" (18700 mm)
c	13' 9" (4200 mm)	e	8' (2450 mm)	f ₁	9' 10" (3000 mm)	l	7' 2" (2200 mm)
c ₁	30' " (9150 mm)	e ₁	5' 3" (1600 mm)	f ₂	2' 4" (700 mm)	m	22' (6710 mm)
		e ₂	4' 11" (1500 mm)	g	45' 11" (14000 mm)	o	6' (150 mm)
		e ₃	17' 8" (5400 mm)	h	12' 11" (3950 mm)		

Truck Carrier

Engine	KHD-BF 12 L 413 F
System	12 cyl.-4 strokes
Output (DIN 70020) at 2100 RPM	353 kW (480 HP)
Cooling	air
Fuel-Tank Capacity	113 gal. (430 liters)
Transmission	* 8-Speed Synchromesh Torque-Converter Main Transmission plus Transfer Case and Differential with Lock-Out Control
Carrier	14 x 8
Driving Axles	1st, 2nd, 5th, 6th
Steering Axles	1st, 2nd, 3rd, 5th, 6th, 7th
Suspension	
Front	1st and 2nd Axles: Leaf springs; 3rd and 4 th = Hydraulic Suspension
Rear	1st and 2nd Axles = Walking Beams, 3rd = Hydraulic Suspension
Outriggers	4 articulated dismountable outrigger beams with hydraulic jack legs

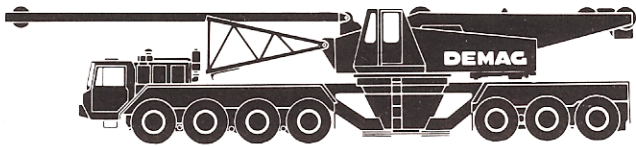

Axle Loads

	1st front	2nd front	3rd front	4th front	1st rear	2nd rear	3rd rear	Total
	tons	tons	tons	tons	tons	tons	tons	tons
Crane in travel order, with basic boom and mast gantry, without outriggers	10.5*	10.5	13.2	13.2	13.2	13.2	13.2	87.0

Change of Road Weight

Deduct for: 2nd Hoist Drum with Cable	-0.31	-0.31	0	0	-1.69	-1.69	0	-4.00
Deduct for: Jib-Boom Luffing Drum with Cable	-0.33	-0.33	0	0	-0.91	-0.91	0	-2.48
Deduct for: Main Hoist and Boom Hoist Cable	-0.65	-0.65	0	0	-1.98	-1.98	0	-5.26
Deduct for: 2nd Hoist Cable	-0.20	-0.20	0	0	-1.07	-1.07	0	-2.54
Deduct for: Jib-Boom Luffing Cable	-0.15	-0.15	0	0	-0.42	-0.42	0	-1.14
Deduct for: Basic Boom plus Mast Gantry	-3.10	-3.10	0	0	+0.23	+0.23	0	-5.74

Carrier Weight

	10.5	10.5	0*	0	10.4	10.4	0	41.8
--	------	------	----	---	------	------	---	------

* When adjusting the load on each of the 3rd, and 4th front axle and the 3rd rear axle to a certain value "X", the load on each of the 1st and 2nd front axle will be reduced by "X" multiplied by 1.28 t, and on each of the 1st and 2nd rear axle by "X" multiplied by 2.03 t.

Carrier Performance

Travel Speeds	0 ... 38.4 mph (0 ... 61.9 km/h)
Gradeability	max. 30.7%

Superstructure

Engine	KHD-F 10 L 413 F
Output at 2300 RPM	196 kW (267 HP)
Transmission	Axial-Piston Hydraulic Pumps
Drum Drive	Axial-Piston Hydraulic Motor and Planetary Drive
Swing Drive	Axial-Piston Hydraulic Motor and Planetary Drive
Control	Hydraulic

Working Speeds

	Infinitely variable
Main Hoist	max. 295 ft./min. (max. 90 m/min.)
Aux. Hoist	max. 387 ft./min. (max. 118 m/min.)
Aux. Boom Hoist	max. 141 ft./min. (max. 43 m/min.)
Main Boom Hoist	max. 118 ft./min. (max. 36 m/min.)
Swing	1.1 RPM

Cables

Main Hoist: Rope Pull, Single Line	(75%) 27.557 lbs. (12500 kg) (85%) 31.300 lbs. (14200 kg)	Aux. Hoist: Rope Pull, Single Line	(75%) 20.282 lbs. (9200 kg)
Length of Cable	2789 ft. (850 m)	Length of Cable	2460 ft. (750 m)
Dia. of Cable	1 ^{7/64} " (28 mm)	Dia. of Cable	1 ^{1/32} " (26 mm)

Boom

	Main Boom	Max. Allowable Lifting Load	Main Boom + Jib Boom
Heavy-Duty Hammer Head	39–59 ft. (12–18 m)	440 tons (400 t)	–
Universal Head	39–295 ft. (12–90 m)	350 tons (300 t)	276 + 236 ft. (84 + 72 m)

TC 2000

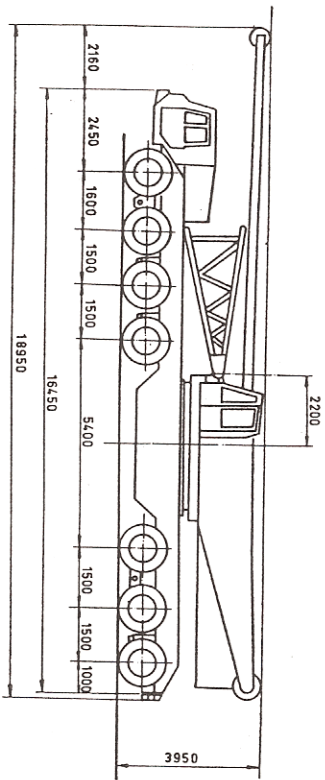

TC 2000

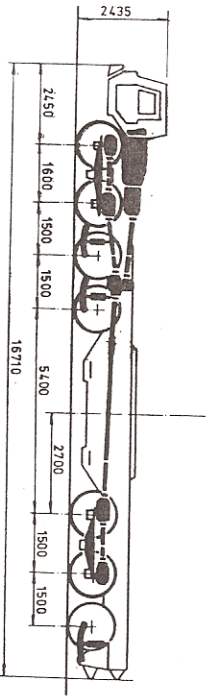

TC 2000

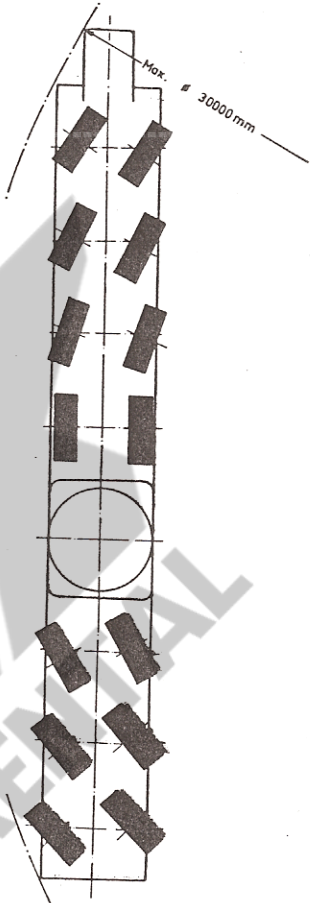

TC 2000

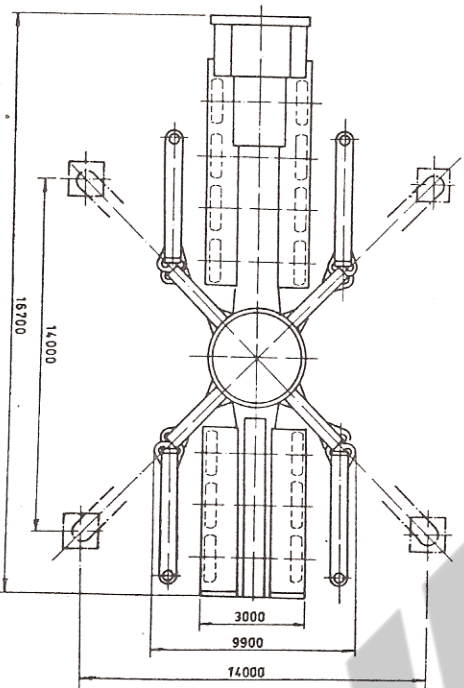

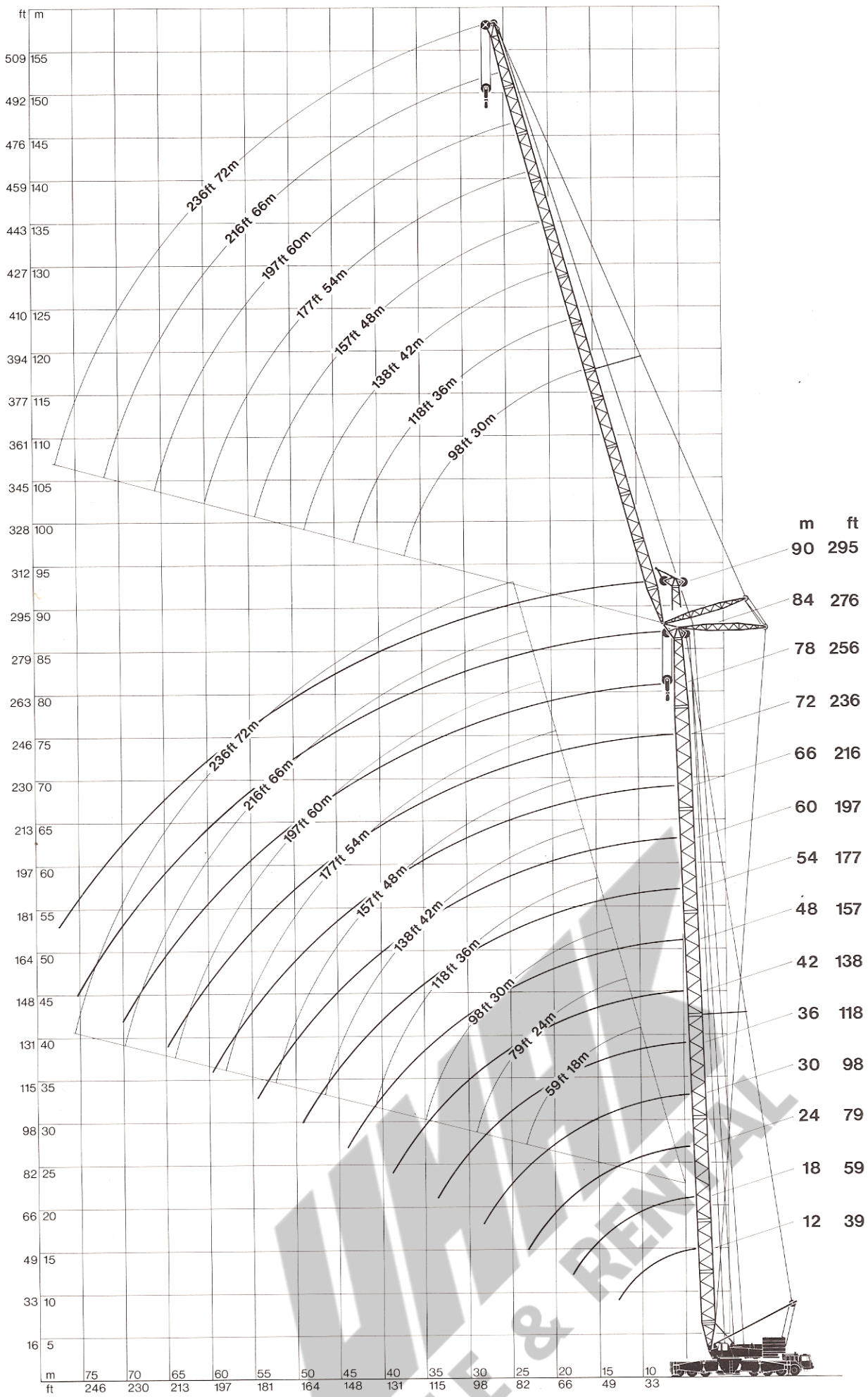



Lifting Capacities on Main Boom

46' by 46' Outriggers
360 degrees 85%

132 tons Counterweight

Radius ft	Length of Main Boom													
	39 ft	59 ft	79 ft	98 ft	118 ft	138 ft	157 ft	177 ft	197 ft	216 ft	236 ft	256 ft	276 ft	295 ft
18	440*	440*	-	-	-	-	-	-	-	-	-	-	-	-
20	398*	398*	-	-	-	-	-	-	-	-	-	-	-	-
23	350	350	348	344	292	-	-	-	-	-	-	-	-	-
26	313	311	310	309	269	253	-	-	-	-	-	-	-	-
30	275	273	272	269	250	236	222	196	-	-	-	-	-	-
33	245	244	242	239	234	222	211	188	163	135	112	99.9	-	-
39	201	199	198	196	194	193	192	170	152	126	104	90.0	76.3	62.4
46	-	169	167	163	162	162	162	155	141	118	97.7	83.4	70.2	55.9
53	-	146	144	143	141	140	138	137	133	111	91.1	77.9	64.7	51.0
59	-	128	126	125	124	123	122.9	122	121	104	85.6	72.4	60.3	47.1
66	-	-	113	112	111	110	109	108	107	96.6	80.1	68.0	55.9	43.3
72	-	-	103	101	100	98.8	97.7	96.9	96.0	89.4	75.7	63.8	52.1	40.5
79	-	-	-	92.1	90.8	89.6	88.5	87.5	86.6	82.3	71.3	59.2	48.2	37.8
85	-	-	-	84.4	82.9	81.8	80.7	79.7	78.8	75.7	66.9	55.9	44.9	35.6
92	-	-	-	77.9	76.3	75.2	74.0	73.1	72.1	70.7	63.6	52.6	42.3	32.4
98	-	-	-	-	70.7	69.5	68.3	67.2	66.4	63.6	59.2	49.3	39.4	31.4
112	-	-	-	-	-	60.1	58.9	57.8	57.2	53.7	51.5	42.7	34.6	28.4
125	-	-	-	-	-	53.0	50.8	50.0	49.6	47.1	44.9	38.3	30.6	24.6
138	-	-	-	-	-	-	44.7	43.5	42.7	40.5	38.9	32.8	27.3	21.8
151	-	-	-	-	-	-	-	38.5	37.8	35.8	33.9	28.4	24	19.6
164	-	-	-	-	-	-	-	-	33.4	31.6	30.1	25.3	21.3	17.4
177	-	-	-	-	-	-	-	-	29.4	28.1	26.8	21.8	19.1	15.2
190	-	-	-	-	-	-	-	-	-	25.4	23.7	19.6	16.9	13.4
203	-	-	-	-	-	-	-	-	-	-	21.3	17.4	13.4	11.6
216	-	-	-	-	-	-	-	-	-	-	-	15.2	12.9	9.9
229	-	-	-	-	-	-	-	-	-	-	-	13.6	12.0	8.5

Lifting Capacities on Main Boom

46' by 46' Outriggers
360 degrees 85%

112 tons Counterweight

Radius ft	Length of Main Boom													
	39 ft	59 ft	79 ft	98 ft	118 ft	138 ft	157 ft	177 ft	197 ft	216 ft	236 ft	256 ft	276 ft	295 ft
18	350	350	-	-	-	-	-	-	-	-	-	-	-	-
20	346	345	-	-	-	-	-	-	-	-	-	-	-	-
23	315	314	310	310	292	-	-	-	-	-	-	-	-	-
26	281	280	279	278	270	253	-	-	-	-	-	-	-	-
30	251	250	248	247	245	236	222	196	-	-	-	-	-	-
33	226	225	224	223	220	219	211	188	163	135	112	-	-	-
39	189	188	187	185	183	182	180	170	152	126	104	90	76	62
46	-	-	159	157	156	155	154	153	141	118	97	83	70	56
53	-	-	138	136	135	134	133	132	132	111	91	78	64	51
59	-	-	122	120	118	117	116	115	115	104	85	72	60	47
66	-	-	108	106	105	104	103	102	101	96	80	68	56	43
72	-	-	97	95	94	93	92	91	90	89	75	63	52	40
79	-	-	-	87	86	85	84	82	81	80	71	59	48	37
85	-	-	-	79	78	77	76	74	73	72	67	56	45	35
92	-	-	-	73	72	71	70	68	67	66	63	52	42	32
98	-	-	-	-	67	64	63	62	61	60	59	49	39	31
112	-	-	-	-	-	54	53	52	51	50	50	42	34	28
125	-	-	-	-	-	47	46	45	44	43	43	38	30	24
138	-	-	-	-	-	-	39	38	37	36	36	32	27	21
151	-	-	-	-	-	-	-	34	33	32	31	28	24	19
164	-	-	-	-	-	-	-	-	29	28	27	25	21	17
177	-	-	-	-	-	-	-	-	25	24	23	21	19	15
190	-	-	-	-	-	-	-	-	-	22	21	19	17	13
203	-	-	-	-	-	-	-	-	-	-	18	16	14	11
216	-	-	-	-	-	-	-	-	-	-	-	14	12	9
229	-	-	-	-	-	-	-	-	-	-	-	12	11	8

SALE & RENTAL



Lifting Capacities on Main Boom 46' by 46' Outriggers 72 tons Counterweight
360 degrees 85%

Radius ft	Length of Main Boom													
	39 ft	59 ft	79 ft	98 ft	118 ft	138 ft	157 ft	177 ft	197 ft	216 ft	236 ft	256 ft	276 ft	295 ft
26	260	260	259	258	257	253	-	-	-	-	-	-	-	-
30	234	233	231	229	228	226	223	-	-	-	-	-	-	-
33	212	209	208	207	205	204	203	188	164	136	112	-	-	-
39	177	174	173	172	170	169	168	167	153	127	104	90	-	-
46	-	149	148	147	146	145	143	142	141	119	98	83	-	-
53	-	130	129	128	126	125	124	123	122	112	91	78	-	-
59	-	116	115	113	112	111	110	109	108	104	85	72	-	-
66	-	-	97	96	95	94	93	93	92	92	80	68	-	-
72	-	-	83	82	81	80	79	79	78	78	75	63	-	-
79	-	-	-	71	70	69	68	68	67	67	67	59	-	-
85	-	-	-	63	62	61	60	60	59	59	58	56	-	-
92	-	-	-	57	56	55	54	53	52	52	51	51	-	-
98	-	-	-	-	50	49	48	47	47	46	46	45	-	-
112	-	-	-	-	-	41	40	39	38	37	37	36	-	-
125	-	-	-	-	-	34	33	32	31	31	30	30	-	-
138	-	-	-	-	-	-	29	28	27	26	25	25	-	-
151	-	-	-	-	-	-	-	24	23	22	21	21	-	-
164	-	-	-	-	-	-	-	-	20	19	18	17	-	-
177	-	-	-	-	-	-	-	-	17	16	15	14	-	-
190	-	-	-	-	-	-	-	-	-	14	13	12	-	-
203	-	-	-	-	-	-	-	-	-	-	11	10	-	-
216	-	-	-	-	-	-	-	-	-	-	-	8	-	-
229	-	-	-	-	-	-	-	-	-	-	-	-	7	-

Lifting Capacities on Main Boom 23' by 23' Outriggers 112 tons Counterweight
360 degrees 85%

Radius ft	Length of Main Boom													
	39 ft	59 ft	79 ft	98 ft	118 ft	138 ft	157 ft	177 ft	197 ft	216 ft	236 ft	256 ft	276 ft	295 ft
16	250	-	-	-	-	-	-	-	-	-	-	-	-	-
20	235	235	-	-	-	-	-	-	-	-	-	-	-	-
23	216	216	216	216	-	-	-	-	-	-	-	-	-	-
26	172	172	172	172	171	-	-	-	-	-	-	-	-	-
30	163	163	162	162	161	161	-	-	-	-	-	-	-	-
33	153	153	152	152	150	149	149	148	135	-	-	-	-	-
39	116	115	115	114	114	113	112	111	110	-	-	-	-	-
46	-	92	91	90	89	89	88	88	88	-	-	-	-	-
53	-	77	76	75	75	74	73	72	72	-	-	-	-	-
59	-	66	65	64	63	62	62	61	60	-	-	-	-	-
66	-	-	56	56	55	54	53	52	51	-	-	-	-	-
72	-	-	50	49	48	47	46	46	45	-	-	-	-	-
79	-	-	-	44	43	42	41	40	39	-	-	-	-	-
85	-	-	-	39	38	37	36	36	35	-	-	-	-	-
92	-	-	-	36	35	34	33	32	31	-	-	-	-	-
98	-	-	-	-	31	31	30	29	28	-	-	-	-	-
112	-	-	-	-	-	26	25	24	23	-	-	-	-	-
125	-	-	-	-	-	22	21	20	19	-	-	-	-	-
138	-	-	-	-	-	-	18	17	16	-	-	-	-	-
151	-	-	-	-	-	-	-	14	13	-	-	-	-	-
164	-	-	-	-	-	-	-	-	10	-	-	-	-	-
177	-	-	-	-	-	-	-	-	7	-	-	-	-	-
190	-	-	-	-	-	-	-	-	-	-	-	-	-	-
203	-	-	-	-	-	-	-	-	-	-	-	-	-	-
216	-	-	-	-	-	-	-	-	-	-	-	-	-	-
229	-	-	-	-	-	-	-	-	-	-	-	-	-	-

SALE & RENTAL



Lifting Capacities on Main Boom

23' by 23' Outriggers
360 degrees 85%

72 tons Counterweight

Radius ft	Length of Main Boom													
	39 ft	59 ft	79 ft	98 ft	118 ft	138 ft	157 ft	177 ft	197 ft	216 ft	236 ft	256 ft	276 ft	295 ft
16	250	-	-	-	-	-	-	-	-	-	-	-	-	-
20	235	235	-	-	-	-	-	-	-	-	-	-	-	-
23	216	216	216	216	-	-	-	-	-	-	-	-	-	-
26	172	170	169	168	167	-	-	-	-	-	-	-	-	-
30	139	138	137	136	135	134	-	-	-	-	-	-	-	-
33	118	116	115	114	113	112	112	111	110	-	-	-	-	-
39	89	88	87	85	84	84	83	82	81	-	-	-	-	-
46	-	70	69	68	67	66	65	64	63	-	-	-	-	-
53	-	58	57	56	55	54	53	52	51	-	-	-	-	-
59	-	50	48	47	46	45	44	43	42	-	-	-	-	-
66	-	-	42	40	39	38	37	36	36	-	-	-	-	-
72	-	-	37	35	34	33	32	31	31	-	-	-	-	-
79	-	-	-	31	30	29	28	27	26	-	-	-	-	-
85	-	-	-	28	27	26	25	24	23	-	-	-	-	-
92	-	-	-	25	24	23	22	21	20	-	-	-	-	-
98	-	-	-	-	21	20	19	18	17	-	-	-	-	-
112	-	-	-	-	-	17	16	15	13	-	-	-	-	-
125	-	-	-	-	-	14	13	11	10	-	-	-	-	-
138	-	-	-	-	-	-	10	9	8	-	-	-	-	-
151	-	-	-	-	-	-	-	6	-	-	-	-	-	-
164	-	-	-	-	-	-	-	-	-	-	-	-	-	-
177	-	-	-	-	-	-	-	-	-	-	-	-	-	-
190	-	-	-	-	-	-	-	-	-	-	-	-	-	-
203	-	-	-	-	-	-	-	-	-	-	-	-	-	-
216	-	-	-	-	-	-	-	-	-	-	-	-	-	-
229	-	-	-	-	-	-	-	-	-	-	-	-	-	-

Crane-Capacity Notes

Capacities do not exceed 85%/75% of tipping load
 Max. wind pressure: 15 kg/m² Δ 15,5 m/sec (85%)
 25 kg/m² Δ 20 m/sec (75%)
 Crane operation up to a wind force of 5^o Beaufort scale
 (5 kg/m² Δ 9 m/sec) permissible.

The weights of all load-handling devices are considered part of the load, and suitable allowance for them should be made.

The 75% crane ratings furthermore comply with DIN 15019,2 (test load = 1.25x lifting load + 0.1 x dead weight of boom reduced to the boom point)

All capacities above the parting line are based upon structural strength. The capacities below the parting line are based on stability.

* With Heavy-Duty Hammer Head

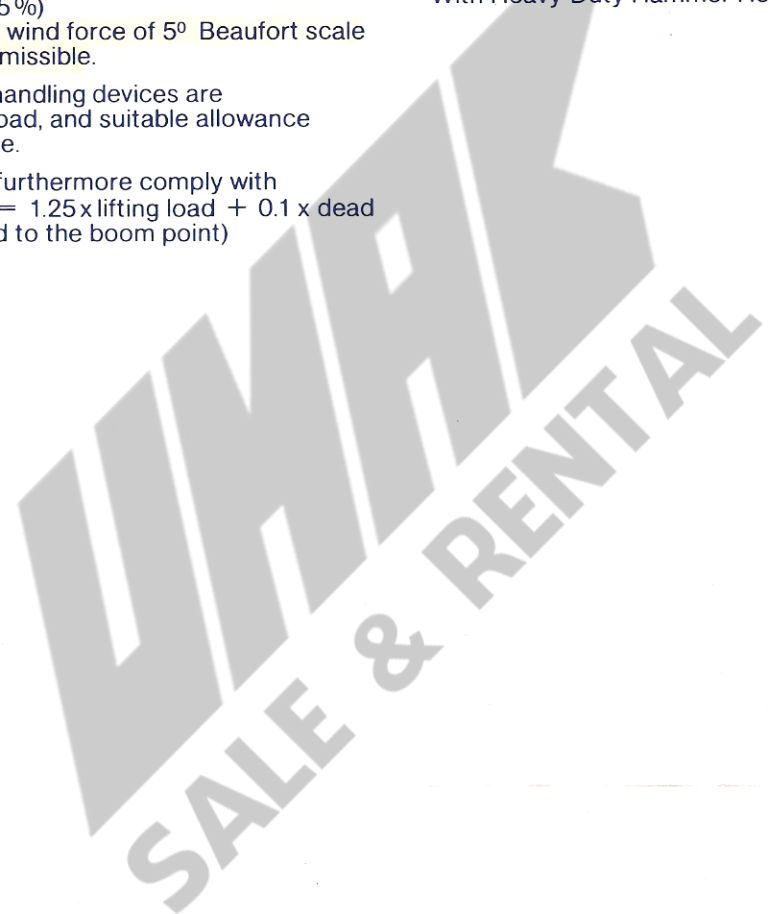

Hook Blocks

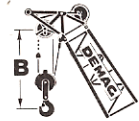

Number of Sheaves	Capacity	Weight	"B"
16	440 tons (400 t)	12.257 lbs. (5560 kg)	11 ft. (3.50 m)
13	330 tons (300 t)	9.094 lbs. (4125 kg)	10 ft. (3.20 m)
6	120 tons (110 t)	4.938 lbs. (2240 kg)	8 ft. (2.50 m)
1	35 tons (32 t)	2.557 lbs. (1160 kg)	6 ft. (2.00 m)



**ROCKY MOUNTAIN CRANE
SERIVICE, INC.**
135 CRANE LANE
SALIDA, CO 81201



Subject to change without notice

Printed in West-Germany

Mannesmann Demag Corporation
Construction Machinery Division
468 Country Club Drive
Bensenville, Illinois 60106

D 830 013 01/82 KA 1Te

WMAK
SALE & RENTAL