

## Demag CC 2800

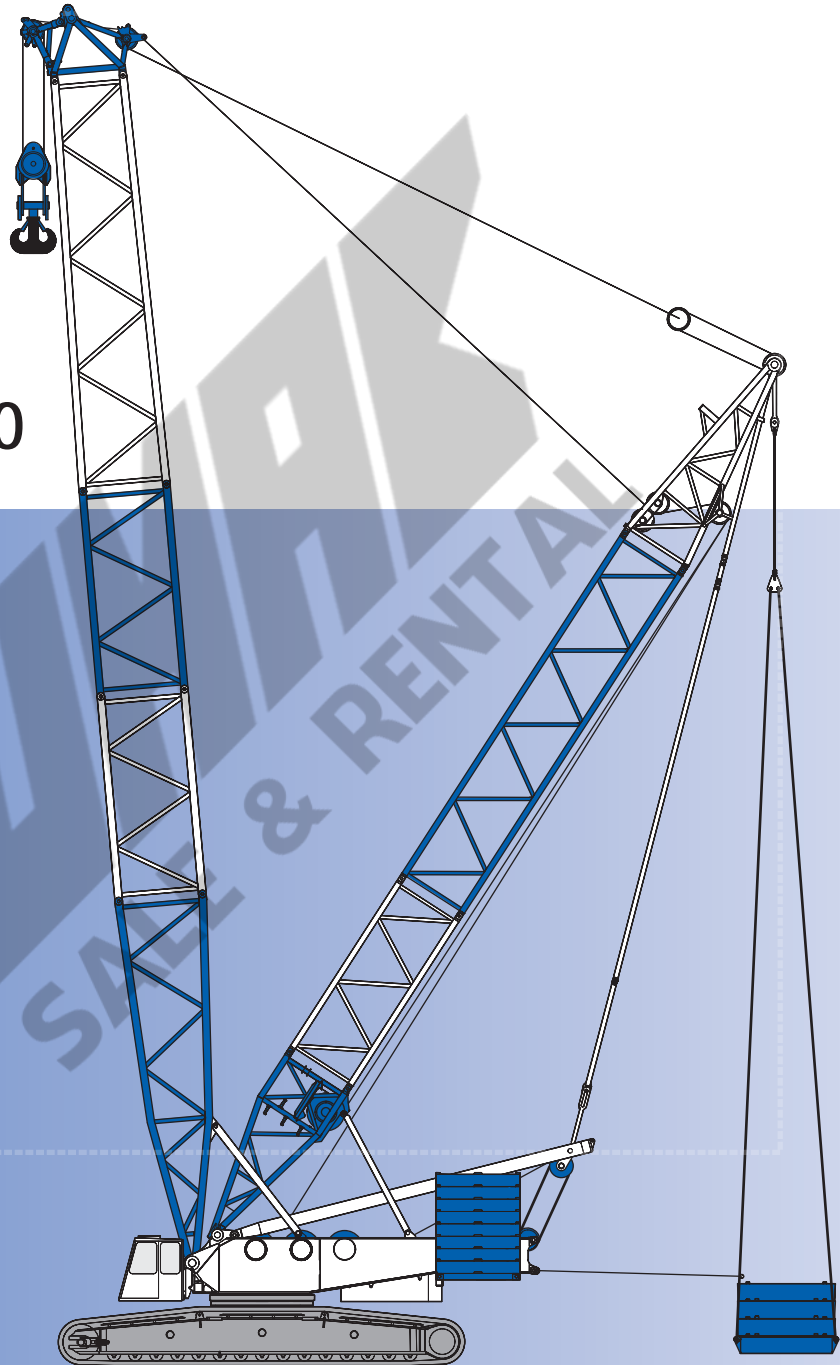

**600t**

[MAIN MENUE](#)

[Inhalt](#)

[Contents](#)

[Contenu](#)

- Highlights
- Contents
- Key
- Specifications
- Boom combinations
- Main boom
- Luffing fly jib
- Fixed fly jib
- Technical description

## Demag CC 2800

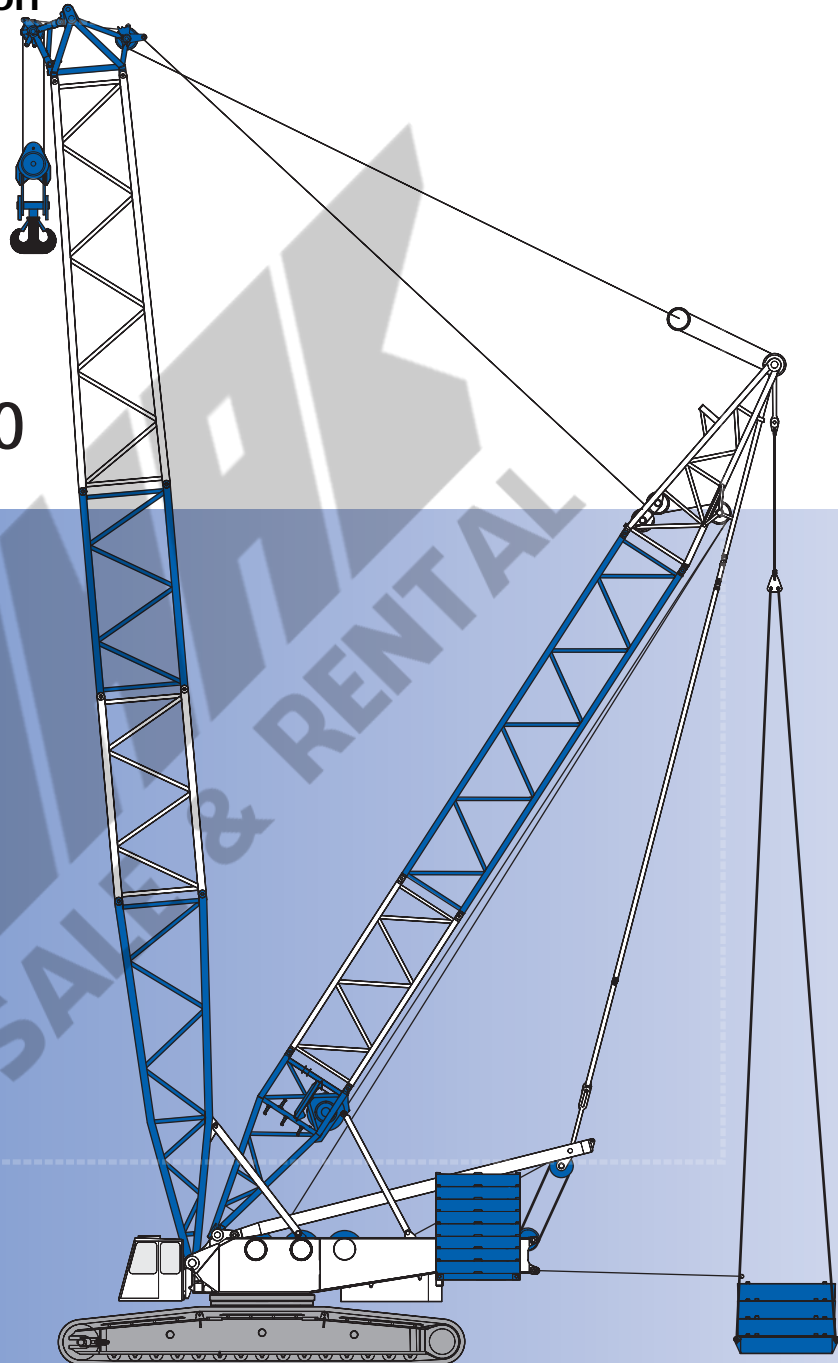

**600t**

[MAIN MENUE](#)

[Inhalt](#)

[Contents](#)

[Contenu](#)

- Highlights
- Contenu
- Légende
- Caractéristiques
- Combinaisons de flèche
- Portées flèche principale
- Portées fléchette à volée variable
- Portées fléchette fixe
- Descriptif technique

## Demag CC 2800

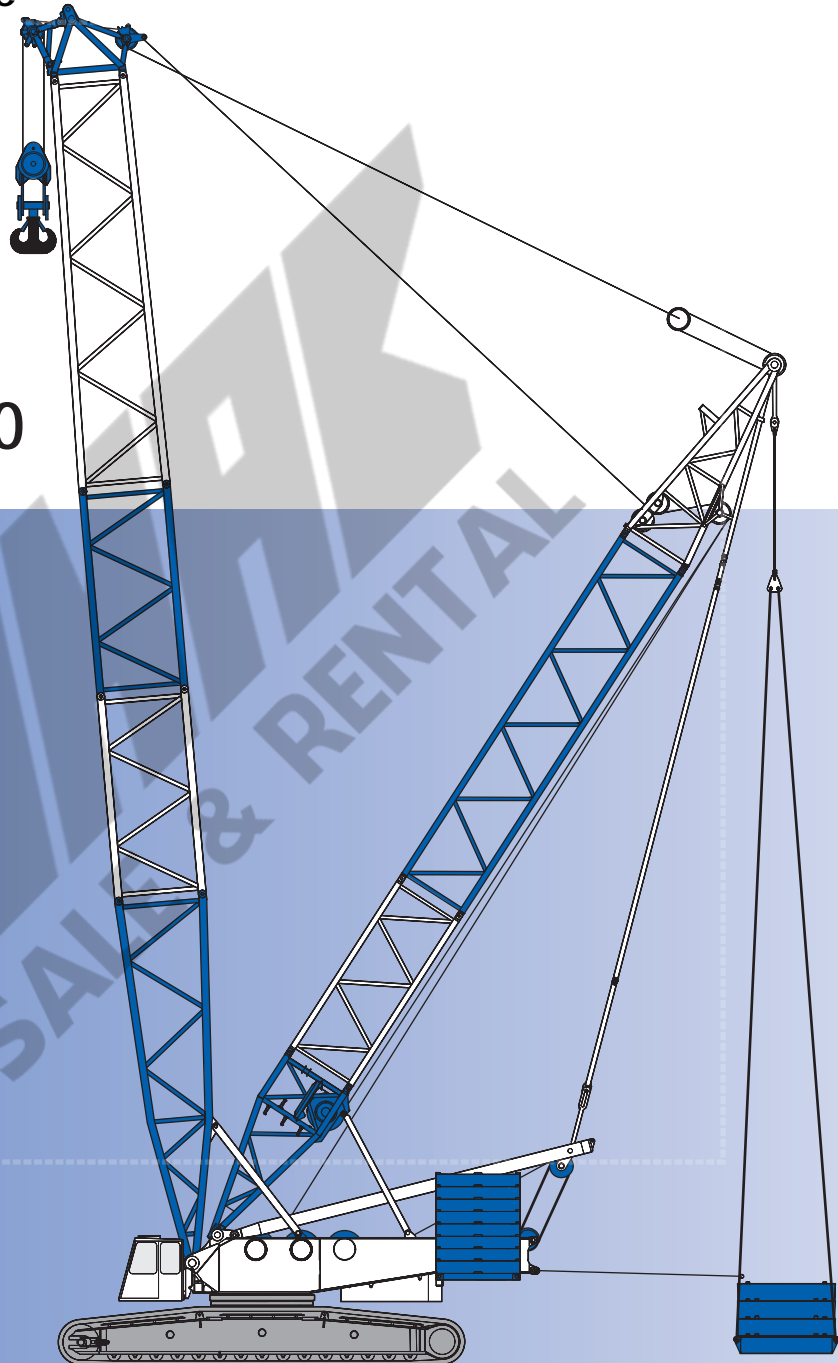

**600t**

[MAIN MENUE](#)

[Inhalt](#)

[Contents](#)

[Contenu](#)

- Highlights
- Inhalt
- Zeichenerklärung
- Technische Daten
- Ausleger-Kombinationen
- Arbeitsbereiche Hauptausleger
- Arbeitsbereiche wippbarer Hilfsausleger
- Arbeitsbereiche starrer Hilfsausleger
- Technische Beschreibung

## Demag CC 2800

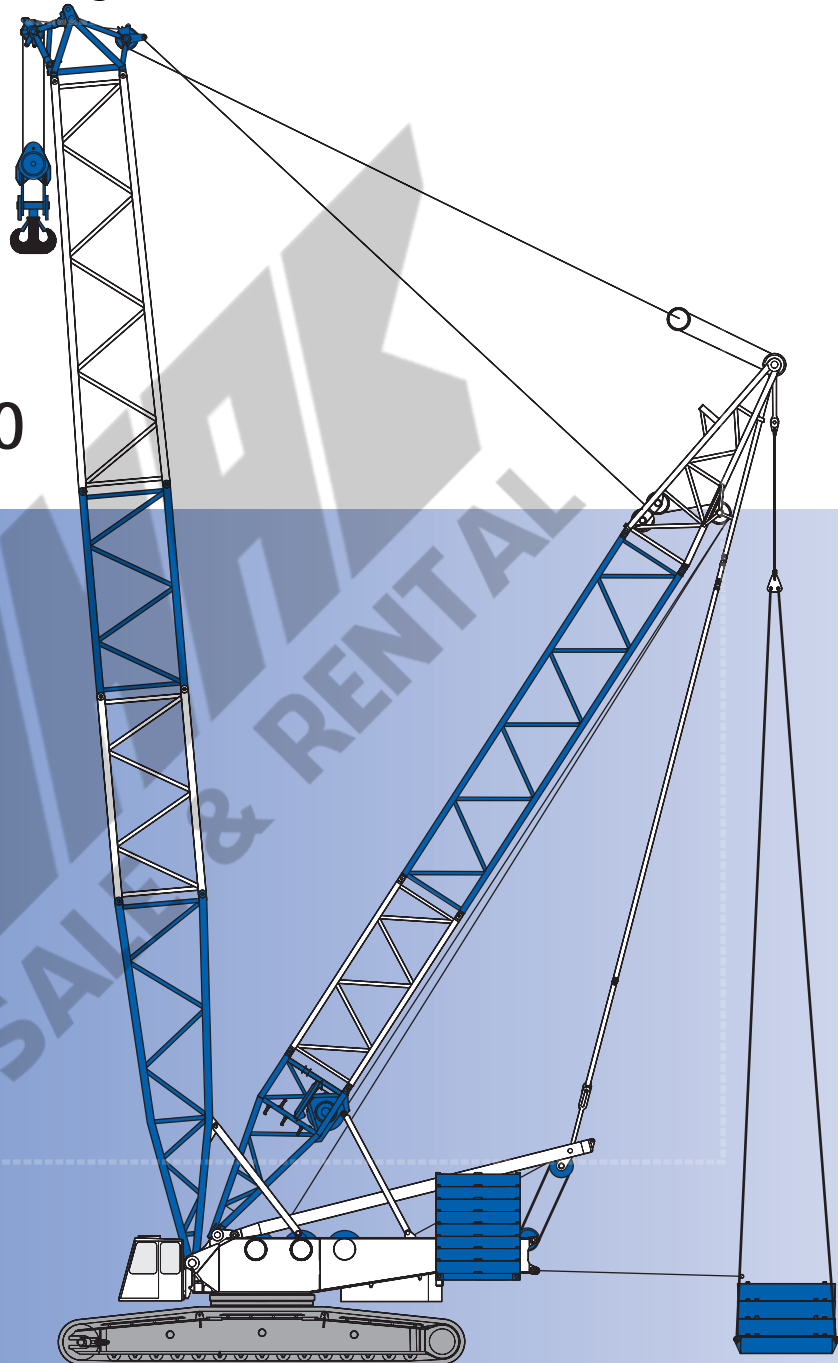

**600t**

[MAIN MENUE](#)

[Inhalt](#)

[Contents](#)

[Contenu](#)

## Demag CC 2800

- ▶ 600 t lifting capacity at 7 m radius
- ▶ excellent lifting capacities throughout the whole working range
- ▶ very simple assembly and short rigging time
- ▶ transport weights reduced to max. 40 t

- ▶ 600 t Tragkraft bei 7 m Ausladung
- ▶ hervorragende Traglasten über alle Arbeitsbereiche
- ▶ enorm vereinfachte Montage und kürzeste Rüstzeiten
- ▶ Reduzierung der Transportgewichte < 40 t je Einzelkomponente

- ▶ capacité de levage 600 t à 7 m de portée
- ▶ excellentes capacités de levage dans toutes les utilisations
- ▶ assemblage considérablement simplifié et temps de montage minimal
- ▶ poids de transport réduit à max. 40 t

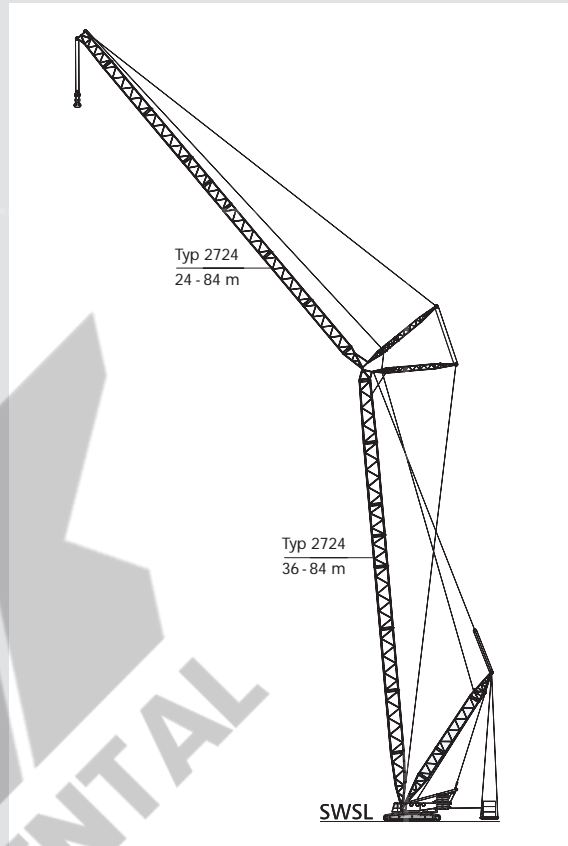

WWW. [demag24.com](http://demag24.com)

### Specifications · Technische Daten · Caractéristiques

Specifications · Technische Daten · Caractéristiques	4
Boom combinations · Ausleger-Kombinationen · Combinaisons de flèche	8
Specifications · Technische Daten · Caractéristiques	10

### Main boom · Hauptausleger · Flèche principale

Working ranges · Arbeitsbereiche · Portées (SH, SH / LH)	11
Lifting capacities · Tragfähigkeiten · Capacités de levage (SH, SH / LH)	12
Lifting capacities with Superlift · Tragfähigkeiten mit Superlift · Capacités de levage avec Superlift (SSL, SSL / LSL)	14
Working ranges with Superlift · Arbeitsbereiche mit Superlift · Portées avec Superlift (SSL, SSL / LSL)	20

### Fixed fly jib · Starrer Hilfsausleger · Fléchette fixe

Working ranges, 10° · Arbeitsbereiche, 10° · Portées, 10° (LF, SH / LH + LF)	21
Lifting capacities · Tragfähigkeiten · Capacités de levage (LF, SH / LH + LF)	22
Working ranges, 30° · Arbeitsbereiche, 30° · Portées, 30° (LF, SH / LH + LF)	24
Working ranges with SL, 10° · Arbeitsbereiche mit SL, 10° · Portées avec SL, 10° (SSL + LF, SSL / LSL + LF)	25
Lifting capacities with SL · Tragfähigkeiten mit SL · Capacités de levage avec SL (SSL + LF, SSL / LSL + LF)	26
Working ranges with SL, 30° · Arbeitsbereiche mit SL, 30° · Portées avec SL, 30° (SSL + LF, SSL / LSL + LF)	32

### Luffing fly jib · Wippbarer Hilfsausleger · Fléchette à volée variable

Working ranges, main boom 85° · Arbeitsbereiche, Hauptausleger 85° · Portées, flèche 85° (SW)	33
Lifting capacities, main boom 85° · Tragfähigkeiten, Hauptausleger 85° · Capacités de levage, flèche 85° (SW)	34
Working ranges with SL, main boom 85° · Arbeitsbereiche mit SL, Hauptausleger 85° · Portées avec SL, flèche 85° (SWSL)	37
Lifting capacities with SL, main boom 85° · Tragfähigkeiten mit SL, Hauptausleger 85° · Capacités de levage avec SL, flèche 85° (SWSL)	38

### Fixed fly jib · Starrer Hilfsausleger · Fléchette fixe

Working ranges with SL, 15° · Arbeitsbereiche mit SL, 15° · Portées avec SL, 15° (SFSL)	43
Lifting capacities with SL, 15° · Tragfähigkeiten mit SL, 15° · Capacités de levage avec SL, 15° (SFSL)	44
Working ranges SFVL with SL, 13° · Arbeitsbereiche SFVL mit SL, 13° · Portées SFVL avec SL, 13°	49
Lifting capacities SFVL with SL · Tragfähigkeiten SFVL mit SL · Capacités de levage SFVL avec SL	50
Working ranges SFVL with SL, 20° · Arbeitsbereiche SFVL mit SL, 20° · Portées SFVL avec SL, 20°	52

### Technical description · Technische Beschreibung · Descriptif technique

Crawler carrier · Superstructure · Optional equipment	54
Boom configurations S and L	55
Raupenunterwagen · Oberwagen · Zusatzausrüstung	56
Auslegervarianten S und L	57
Châssis à chenilles · Partie tournante · Equipement optionnel	58
Configurations de flèche S et L	59

### Transport example for CC 2800

Transportbeispiel CC 2800 · Exemple de transport pour la CC 2800	60
--	----

# Specifications

## Technische Daten

## Caractéristiques

Working speeds (infinitely variable)  
 Arbeitsgeschwindigkeiten (stufenlos regelbar)  
 Vitesses de travail (réglables sans paliers)

Mechanisms Antriebe Mécanismes	Speeds <sup>1)</sup> Geschwindigkeiten <sup>1)</sup> Vitesses <sup>1)</sup>	Single line pull Seilzug je Strang Effort sur brin simple	Length of hoist rope Länge des Hubseils Longueur du câble de levage
Hoist 1 Hubwerk 1 Treuil de levage 1	max. 120 m / min	158 kN / 141 kN <sup>2)</sup>	900 m
Hoist 2 Hubwerk 2 Treuil de levage 2	max. 120 m / min	158 kN / 141 kN <sup>2)</sup>	900 m
Boom derricking Wippwerk Hauptausleger Variation de flèche	max. 120 m / min		
Boom hoist Einziehwerk Relevage de flèche	max. 52 m / min		
Fly jib hoist Wippwerk Hilfsausleger Variation de volée	max. 120 m / min		
Slewing (RPM) Drehwerk (U/min) Orientation (tr/mn)	0,7		

1) top layer · oberste Lage · couche supérieure

2) without / with reeving effect considered · Angabe ohne / mit Wirkungsgrad der Einscherung · sans / avec effort de mouflage

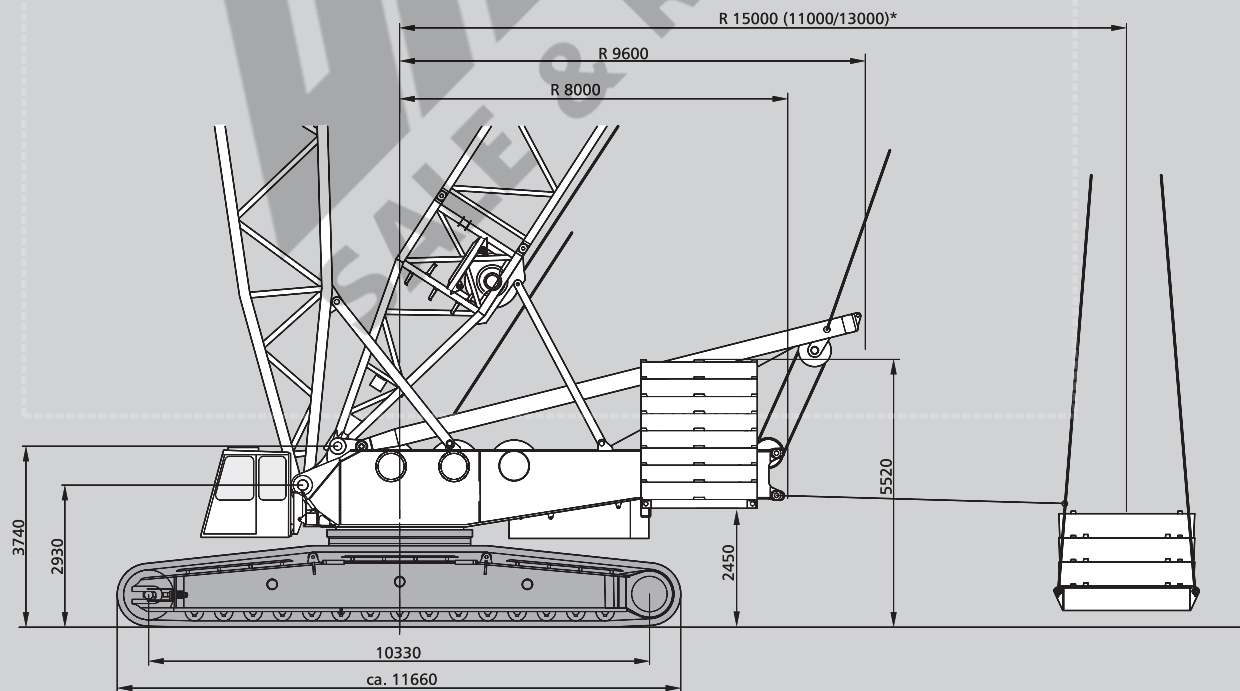

\*optional  
 \*Option  
 \*option

[MAIN MENUE](#)

[Inhalt](#)

[Contents](#)

[Contenu](#)

Hook blocks  
Unterflaschen  
Crochets

Type Typ Type	Possible load Mögliche Traglast Charge possible	Number of sheaves Anzahl der Rollen Nombre de poulies	Number of lines Strangzahl Nombre de brins	Weight Gewicht Poids	„D“
2 x 300 t <sup>1)</sup>	600 t	2 x 11	2 x 22	11 500 kg	5,00 m
2 x 200 t <sup>1)</sup>	400 t	2 x 7	2 x 14	10 000 kg	4,80 m
100 t	100 t	3	7	3 600 kg	4,30 m
50 t	48 t	1	3	2 800 kg	4,00 m
16 t	16 t	-	1	900 kg	3,00 m

<sup>1)</sup> The double hook blocks can be converted into single hook blocks  
Die Doppelunterflaschen können in Einzelunterflaschen umgebaut werden  
Les crochets bimoufles peuvent être transformés en crochets simples

Carrier performance  
Fahrleistungen  
Performances du porteur

1 <sup>st</sup> gear 1. Gang 1 <sup>ère</sup> vitesse	0-0,6 km/h
2 <sup>nd</sup> gear 2. Gang 2 <sup>ème</sup> vitesse	0-1,2 km/h

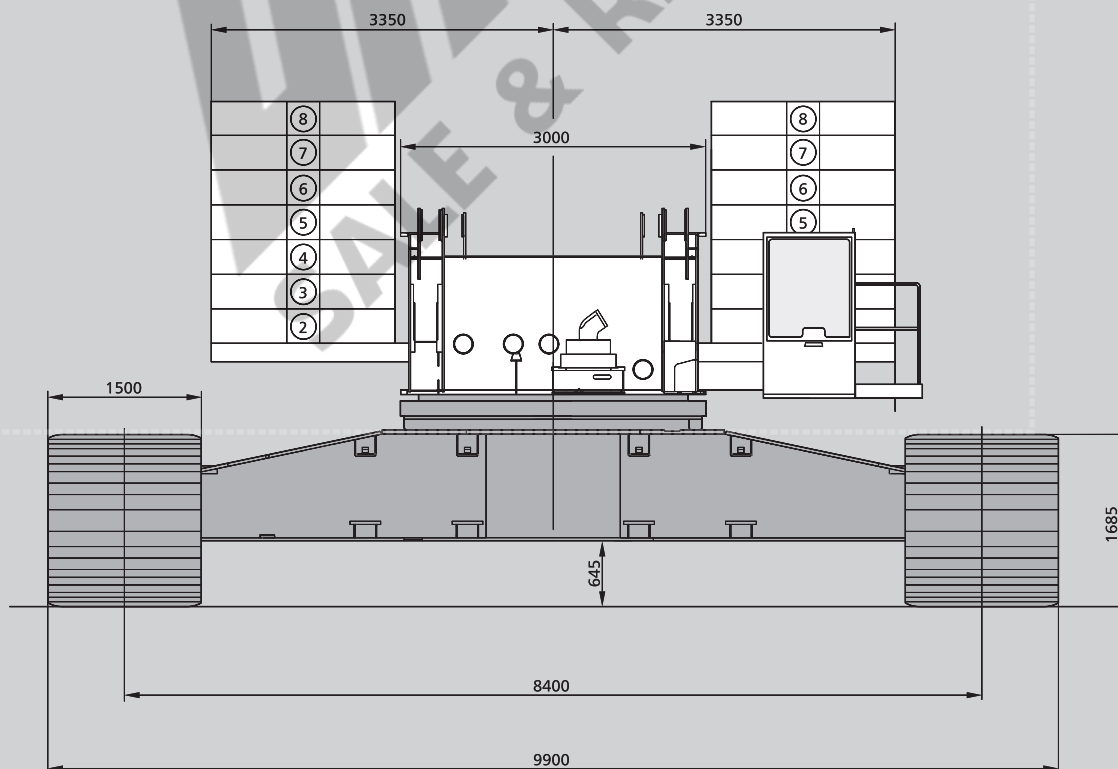

[MAIN MENU](#)

[Inhalt](#)

[Contents](#)

[Contenu](#)



# Specifications

## Technische Daten

## Caractéristiques

### Weights Gewichte Poids

Total weight incl. counterweight 160 t, 24 m SH boom and hook block Gesamtgewicht einschl. Gegengewicht 160 t, 24 m Hauptausleger SH und Unterflasche Poids total avec contrepoids 160 t, flèche SH 24 m et crochet-moufle	360 t
--	-------

Superstructure (with three drums, A-frame, reeving drum and boom backstops) Oberwagen (mit drei Winden, A-Bock, Einscherwinde und Rückfallzylinder) Partie supérieure (avec trois treuils, chevalet, tambour de mouflage et retenues de flèche)	55 t
---	------

Superstructure (without drums H1/H2, reeving winch, boom backstops and A-frame) incl. part of quick-connection Oberwagen (ohne Winden H1/H2, Einscherwinde, Rückfallzylinder und A-Bock) und Anteil Quick-Connection Partie supérieure (sans treuils H1/H2, tambour de mouflage, retenues de flèche et chevalet) incl. partie de connexion rapide	36,8 t
---	--------

Carbody / Carbody with assembly jacks Mittelstück / Mittelstück mit Montageabstützung Partie centrale / Partie centrale avec vérins de montage	26 / 28 t
--	-----------

Crawlers Raupen Chenilles	2 x 40 t
---------------------------------	----------

Counterweight Gegengewicht Contrepoids	160 t
--	-------

### Ground pressure Bodendruck Pression au sol

Ground pressure, based on 360 t total weight Bodendruck bei 360 t Gesamtgewicht Pression au sol, avec un poids total de 360 t	14 N/cm <sup>2</sup>
---	----------------------

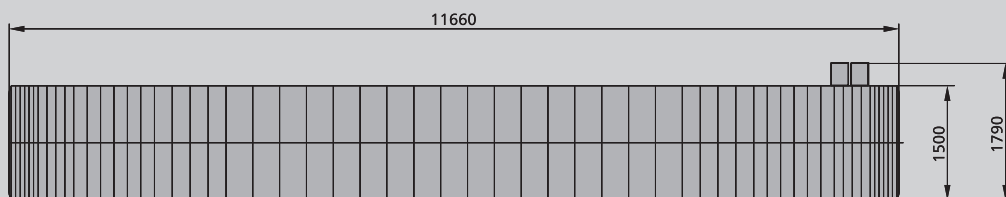
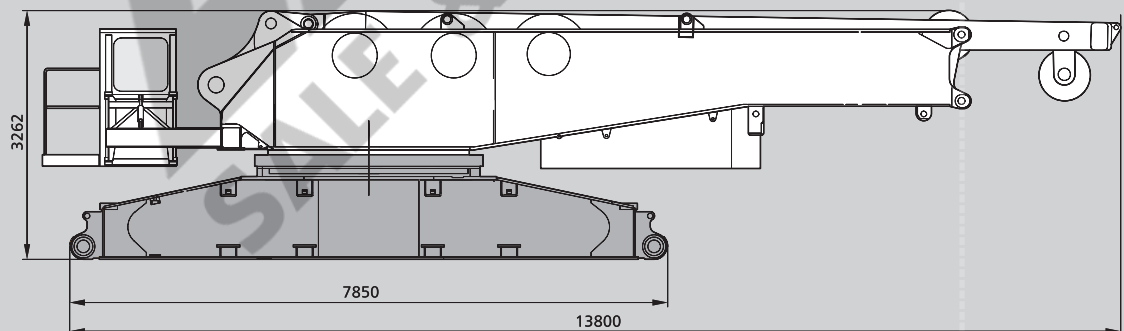

[MAIN MENU](#)

[Inhalt](#)

[Contents](#)

[Contenu](#)

Counterweights on upper  
Gegengewichte OW  
Contrepoids sur partie  
tournante



Central ballast (CB)  
Zentralballast (ZB)  
Lest central (ZB)

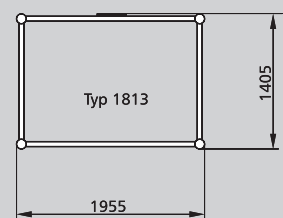
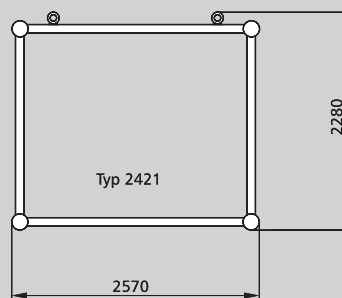
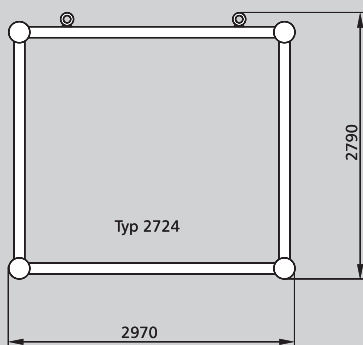
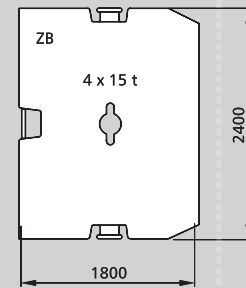
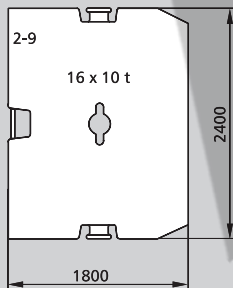
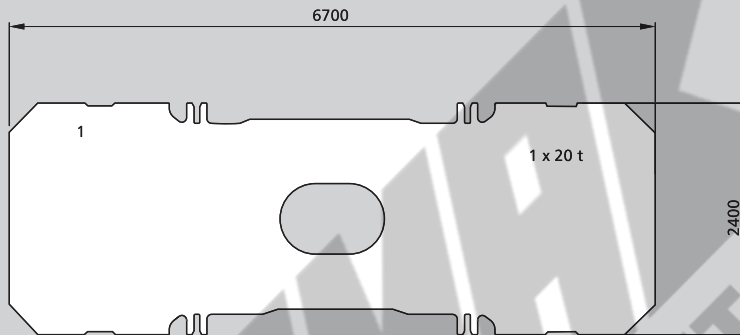
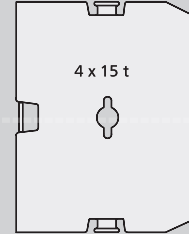

[MAIN MENUE](#)

[Inhalt](#)

[Contents](#)

[Contenu](#)

# Boom combinations Ausleger-Kombinationen Combinaisons de flèche

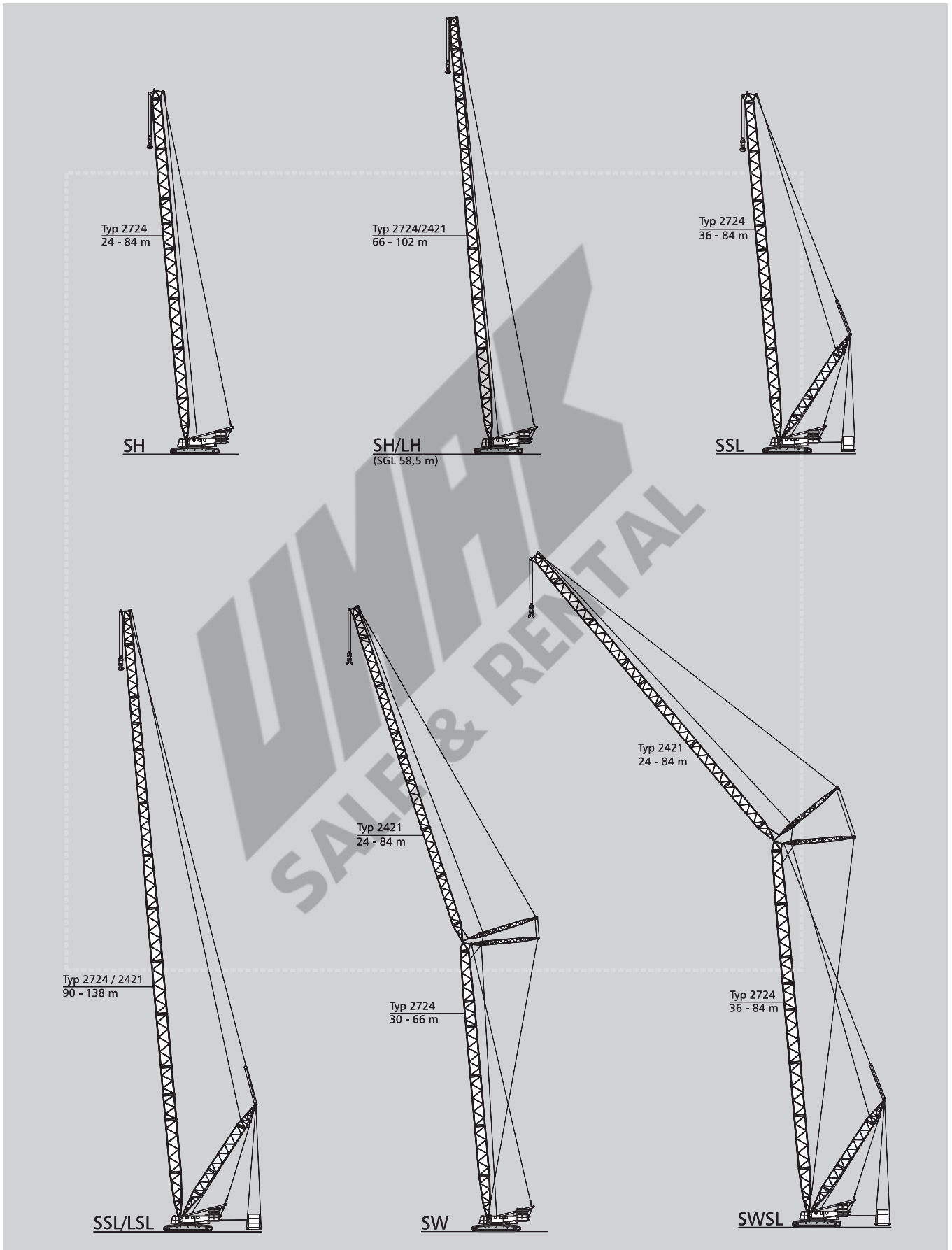

[MAIN MENUE](#)

[Inhalt](#)

[Contents](#)

[Contenu](#)

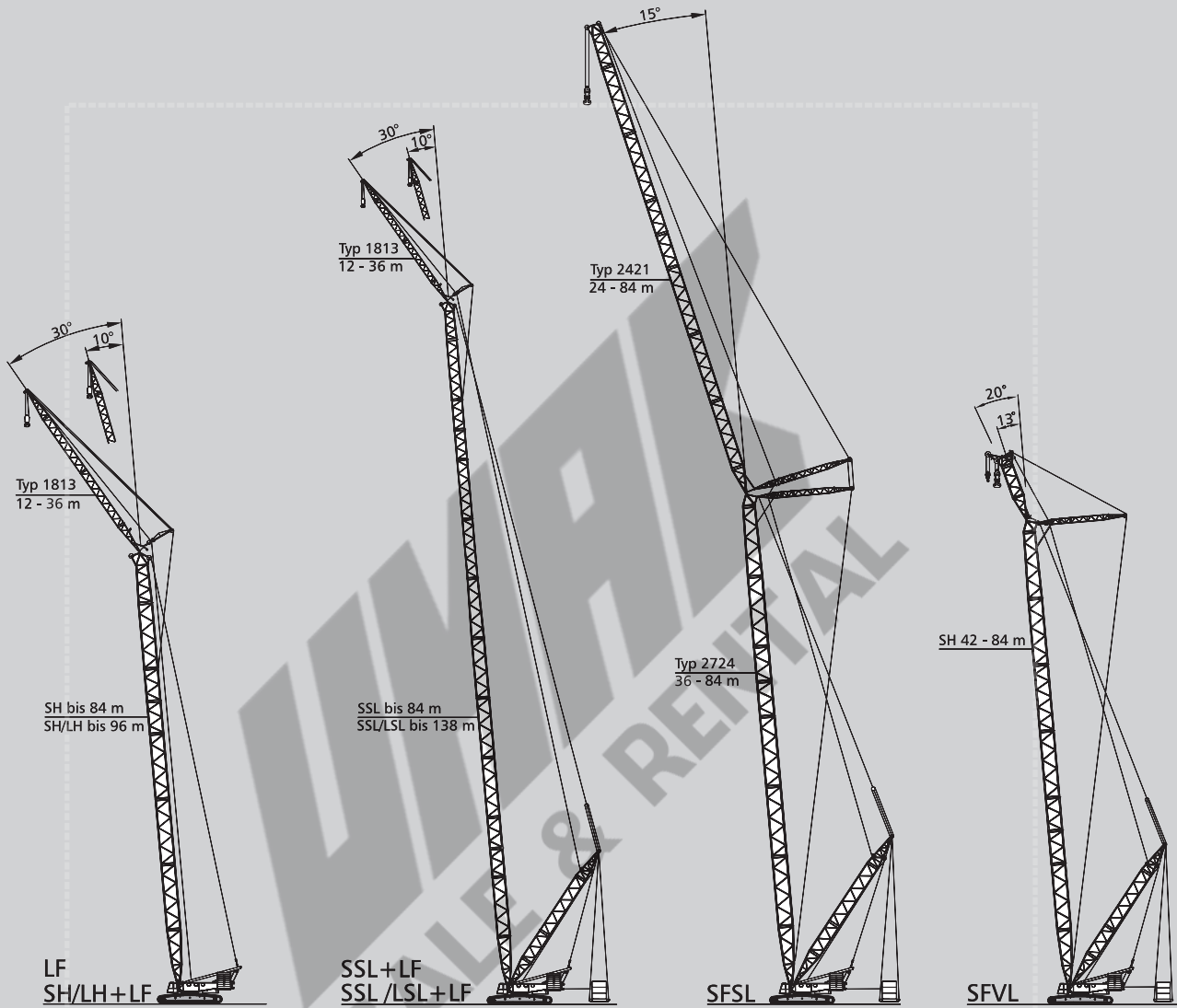

[MAIN MENUE](#)

[Inhalt](#)

[Contents](#)

[Contenu](#)

# Specifications

## Technische Daten

## Caractéristiques

Erection / lowering of the CC 2800 boom systems to the ground  
 Aufrichten / Ablegen der CC 2800 Auslegersysteme  
 Montée / placement sur sol des systèmes de flèche de la CC 2800

Version Variante Version	Main boom Hauptausleger Flèche principale m	Fly jib Hilfsausleger Fléchette m	Counterweight Gegengewicht Contrepoids t	Central ballast Zentralballast Lest central t	Remarks Bemerkungen Observations
SH	24 – 72 78 – 84 **	–	180	60	
SH/LH	66 – 84 90 – 102 **	–	180	60	
SW	30 – 48	24 – 84	180	60	Without add. sheave assembly on boom head Ohne Rollensatz am Hauptausleger Sans jeu de poulies suppl. en tête de flèche
	54 – 66	24 – 84 **	180	60	
LF 10°, 30°	30 – 78	12 – 36	180	60	Without add. sheave assembly on boom head Ohne Rollensatz am Hauptausleger Sans jeu de poulies suppl. en tête de flèche
	84	12 – 36 **	180	60	
LF on/an/sur SH/LH 10°, 30°	30 – 84	12 – 36	180	60	Without add. sheave assembly on boom head Ohne Rollensatz am Hauptausleger Sans jeu de poulies suppl. en tête de flèche
	90 – 102	12 – 36 **	180	60	
SSL	36 – 84	–	–	–	with SL-counterweight mit SL-Gegengewicht avec contrepoids SL
SSL / LSL	90 – 138	–	–	–	with SL-counterweight mit SL-Gegengewicht avec contrepoids SL
SWSL / SFSL / SFVL	36 – 84	24 – 84	–	–	with SL-counterweight mit SL-Gegengewicht avec contrepoids SL

### Remarks · Bemerkungen · Remarques

All versions without runner!  
 Alle Varianten ohne Runner!  
 Toutes les versions sans runner!

Further details on request!  
 Weitere Angaben auf Anfrage!  
 Plus amples détails sur demande!

Erection over idler wheel for all versions!  
 Alle Varianten Aufrichten über Leitrad!  
 Montage par dessus le barbotin pour toutes les versions!

\*\* Only with assist crane or auxiliary equipment

\*\* Nur mit Hilfskran oder Zusatzausrüstung

\*\* Uniquement avec grue auxiliaire ou autre équipement auxiliaire

[MAIN MENU](#)

[Inhalt](#)

[Contents](#)

[Contenu](#)

# Working ranges main boom Arbeitsbereiche Hauptausleger Portées flèche principale

SH, SH/LH

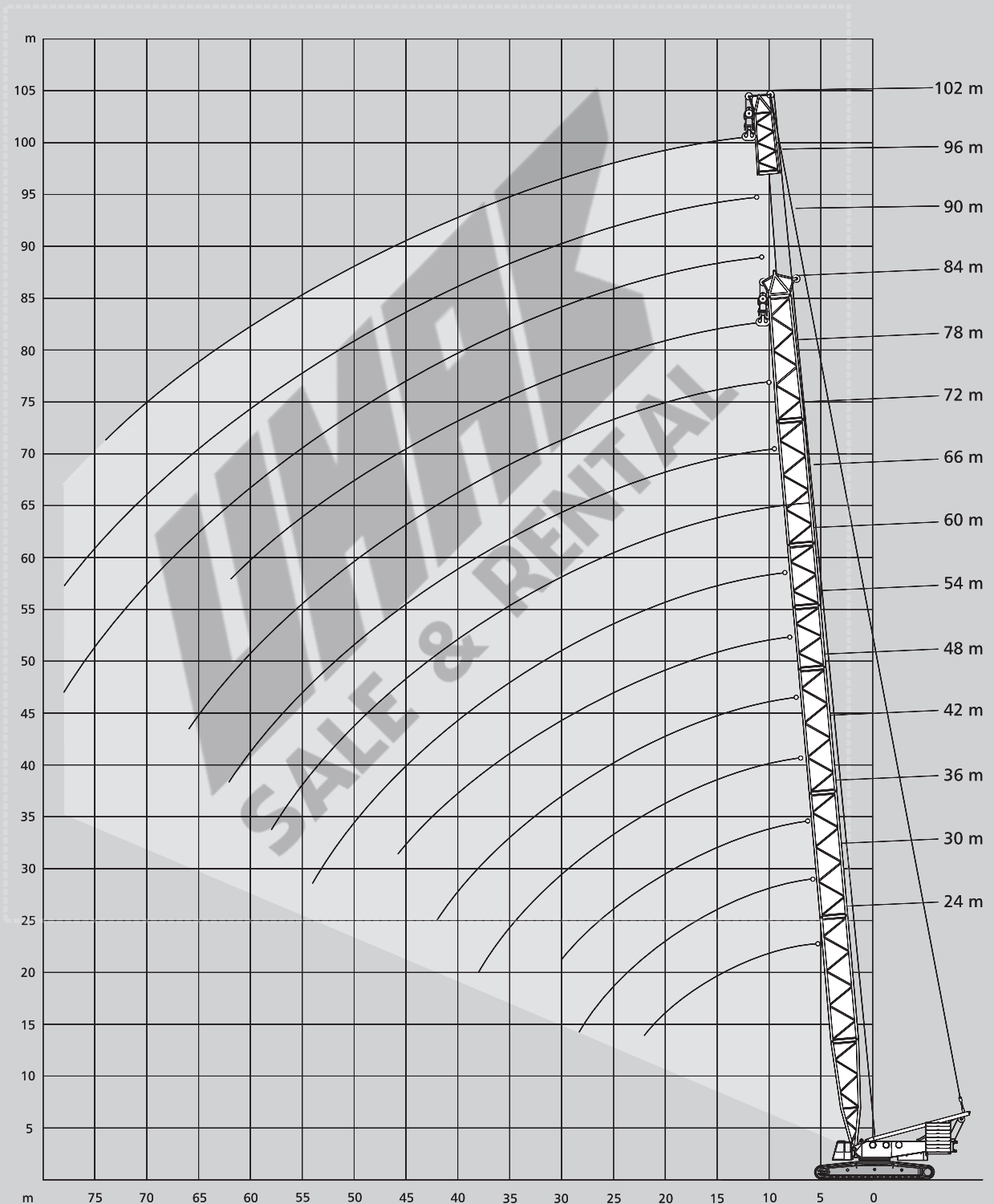

[MAIN MENU](#)

[Inhalt](#)

[Contents](#)

[Contenu](#)

# Lifting capacities main boom

## Tragfähigkeiten Hauptausleger

### Capacités de levage flèche principale

180 t + 60 t ZB  8,40 m 360° DIN/ISO

Radius Ausladung Portée		Main boom · Hauptausleger · Flèche principale										
m		24,0	30,0	36,0	42,0	48,0	54,0	60,0	66,0	72,0	78,0	84,0
t		t	t	t	t	t	t	t	t	t	t	t
	6	600,0	-	-	-	-	-	-	-	-	-	-
	7	573,0	570,0	567,0	-	-	-	-	-	-	-	-
	8	506,0	503,0	499,0	497,0	494,0	-	-	-	-	-	-
	9	405,0	404,0	402,0	401,0	400,0	400,0	399,0	-	-	-	-
	10	333,0	331,0	330,0	328,0	327,0	327,0	326,0	325,0	301,0	-	-
	12	244,0	242,0	240,0	239,0	237,0	237,0	236,0	235,0	235,0	234,0	212,0
	14	191,0	189,0	187,0	186,0	184,0	184,0	183,0	182,0	181,0	181,0	179,0
	16	156,0	154,0	153,0	151,0	149,0	149,0	147,0	147,0	146,0	146,0	144,0
	18	132,0	130,0	128,0	126,0	125,0	124,0	122,0	122,0	121,0	120,0	119,0
	20	113,0	111,0	109,0	108,0	106,0	105,0	104,0	103,0	102,0	101,0	100,0
	22	99,0	97,0	95,0	93,0	92,0	91,0	89,0	89,0	88,0	87,0	85,0
SH	24	-	86,0	84,0	82,0	80,0	79,0	78,0	77,0	76,0	75,0	74,0
	26	-	77,0	75,0	73,0	71,0	70,0	69,0	68,0	67,0	66,0	64,0
	28	-	70,0	67,0	65,0	63,0	62,0	61,0	60,0	59,0	58,0	56,0
	30	-	-	61,0	59,0	57,0	56,0	54,0	53,0	52,0	52,0	50,0
	34	-	-	-	49,0	47,0	45,0	44,0	43,0	42,0	41,0	39,0
	38	-	-	-	41,0	39,0	38,0	36,0	35,0	33,0	32,0	30,0
	42	-	-	-	-	33,0	32,0	30,0	28,0	27,0	26,0	24,0
	46	-	-	-	-	-	27,0	24,0	23,0	22,0	20,0	18,0
	50	-	-	-	-	-	-	20,0	19,0	17,0	16,0	14,0
	54	-	-	-	-	-	-	-	17,0	16,0	14,0	10,0
	58	-	-	-	-	-	-	-	-	13,0	11,0	7,0
	62	-	-	-	-	-	-	-	-	-	9,0	7,0
	66	-	-	-	-	-	-	-	-	-	-	5,0
	70	-	-	-	-	-	-	-	-	-	-	-

160 t  8,40 m 360° DIN/ISO

Radius Ausladung Portée		Main boom · Hauptausleger · Flèche principale										
m		24,0	30,0	36,0	42,0	48,0	54,0	60,0	66,0	72,0	78,0	84,0
t		t	t	t	t	t	t	t	t	t	t	t
	6	427,0	-	-	-	-	-	-	-	-	-	-
	7	406,0	446,0	487,0	-	-	-	-	-	-	-	-
	8	388,0	425,0	423,0	422,0	422,0	-	-	-	-	-	-
	9	334,0	333,0	331,0	330,0	329,0	329,0	328,0	-	-	-	-
	10	274,0	272,0	271,0	269,0	268,0	268,0	267,0	267,0	264,0	-	-
	12	200,0	198,0	197,0	195,0	194,0	193,0	192,0	192,0	191,0	190,0	189,0
	14	156,0	154,0	153,0	151,0	150,0	149,0	148,0	147,0	146,0	146,0	144,0
	16	127,0	126,0	124,0	122,0	121,0	120,0	119,0	118,0	117,0	116,0	115,0
	18	107,0	105,0	103,0	101,0	100,0	99,0	98,0	97,0	96,0	96,0	94,0
SH	20	92,0	90,0	88,0	86,0	84,0	83,0	82,0	82,0	81,0	80,0	78,0
	22	80,0	78,0	76,0	74,0	73,0	72,0	70,0	69,0	69,0	68,0	66,0
	24	-	69,0	67,0	65,0	63,0	62,0	61,0	60,0	59,0	58,0	57,0
	26	-	61,0	59,0	57,0	55,0	54,0	53,0	52,0	51,0	50,0	49,0
	28	-	55,0	53,0	51,0	49,0	48,0	47,0	46,0	45,0	44,0	42,0
	30	-	-	48,0	46,0	44,0	42,0	41,0	40,0	39,0	38,0	36,0
	34	-	-	-	37,0	35,0	34,0	32,0	31,0	30,0	29,0	27,0
	38	-	-	-	31,0	29,0	27,0	25,0	24,0	23,0	22,0	20,0
	42	-	-	-	-	24,0	22,0	20,0	19,0	17,0	16,0	14,0
	46	-	-	-	-	-	18,0	16,0	14,0	13,0	12,0	10,0
	50	-	-	-	-	-	-	13,0	11,0	9,0	8,0	6,0
	54	-	-	-	-	-	-	-	10,0	8,0	7,0	5,0
	58	-	-	-	-	-	-	-	-	6,0	-	-
	62	-	-	-	-	-	-	-	-	-	-	-

[MAIN MENU](#)

[Inhalt](#)

[Contents](#)

[Contenu](#)

**180 t + 60 t ZB**  **8,40 m** **360°** **DIN/ISO**

Radius Ausladung		Main boom · Hauptausleger · Flèche principale						
Portée	m	66,0	72,0	78,0	84,0	90,0	96,0	102,0
	m	t	t	t	t	t	t	t
	9	298,0	-	-	-	-	-	-
	10	298,0	249,0	202,0	-	-	-	-
	12	242,0	242,0	202,0	169,0	154,0	137,0	-
	14	188,0	188,0	174,0	150,0	154,0	137,0	108,0
	16	153,0	153,0	153,0	133,0	142,0	127,0	99,0
	18	128,0	128,0	128,0	119,0	126,0	118,0	91,0
	20	109,0	109,0	109,0	107,0	108,0	107,0	84,0
	22	95,0	95,0	94,0	93,0	93,0	92,0	78,0
	24	83,0	83,0	83,0	82,0	81,0	81,0	72,0
	26	74,0	74,0	73,0	72,0	72,0	71,0	68,0
	28	66,0	66,0	65,0	65,0	64,0	63,0	63,0
<b>SH / LH</b>	30	59,0	59,0	59,0	58,0	57,0	57,0	56,0
	34	49,0	49,0	48,0	47,0	47,0	46,0	46,0
	38	41,0	41,0	40,0	39,0	39,0	38,0	38,0
	42	35,0	34,0	34,0	33,0	32,0	31,0	31,0
	46	30,0	29,0	29,0	27,0	27,0	26,0	25,0
	50	25,0	25,0	24,0	23,0	22,0	21,0	21,0
	54	22,0	21,0	20,0	19,0	18,0	18,0	17,0
	58	19,0	18,0	17,0	16,0	15,0	14,0	14,0
	62	-	16,0	15,0	13,0	13,0	12,0	11,0
	66	-	-	13,0	11,0	10,0	9,0	9,0
	70	-	-	11,0	9,0	8,0	7,0	7,0
	74	-	-	-	8,0	7,0	6,0	5,0
	78	-	-	-	-	5,0	4,0	-
	82	-	-	-	-	-	-	-

**160 t**  **8,40 m** **360°** **DIN/ISO**

Radius Ausladung		Main boom · Hauptausleger · Flèche principale						
Portée	m	66,0	72,0	78,0	84,0	90,0	96,0	102,0
	m	t	t	t	t	t	t	t
	9	298,0	-	-	-	-	-	-
	10	273,0	249,0	202,0	-	-	-	-
	12	198,0	198,0	198,0	169,0	154,0	137,0	-
	14	154,0	154,0	153,0	150,0	152,0	137,0	108,0
	16	124,0	124,0	124,0	123,0	123,0	122,0	99,0
	18	103,0	103,0	103,0	102,0	102,0	101,0	91,0
	20	88,0	88,0	87,0	86,0	86,0	85,0	84,0
	22	76,0	76,0	75,0	74,0	74,0	73,0	73,0
	24	66,0	66,0	66,0	65,0	64,0	64,0	63,0
<b>SH / LH</b>	26	58,0	58,0	58,0	57,0	56,0	56,0	55,0
	28	52,0	52,0	51,0	50,0	50,0	49,0	49,0
	30	46,0	46,0	46,0	45,0	44,0	43,0	43,0
	34	37,0	37,0	37,0	36,0	35,0	34,0	34,0
	38	31,0	31,0	30,0	29,0	28,0	27,0	27,0
	42	25,0	25,0	24,0	23,0	23,0	22,0	21,0
	46	21,0	21,0	20,0	19,0	18,0	17,0	17,0
	50	17,0	17,0	16,0	15,0	14,0	13,0	13,0
	54	14,0	14,0	13,0	12,0	11,0	10,0	10,0
	58	12,0	11,0	11,0	9,0	9,0	8,0	7,0
	62	-	9,0	9,0	7,0	6,0	5,0	5,0
	66	-	-	7,0	5,0	5,0	-	-
	70	-	-	5,0	4,0	-	-	-
	74	-	-	-	-	-	-	-





# Lifting capacities main boom with Superlift Tragfähigkeiten Hauptausleger mit Superlift Capacités de levage flèche principale avec Superlift

180 t + 60 t ZB  8,40 m  SL-Radius 15 m  360°  DIN/ISO

36 m Main boom · Hauptausleger · Flèche principale									
Radius Ausladung Portée									
	t	0	50	100	150	200	250	300	325
m	t	t	t	t	t	t	t	t	t
7	576	600	600	-	-	-	-	-	600
8	502	571	580	586	-	-	-	-	600
9	424	510	562	573	586	-	-	-	600
10	352	451	512	559	576	-	-	-	595
12	257	347	420	472	516	548	-	-	548
14	201	272	344	400	443	480	495	-	495
16	164	223	282	339	385	420	441	-	441
18	137	188	239	290	334	373	389	-	389
20	118	162	206	251	294	330	340	-	340
22	103	142	181	221	260	295	300	-	300
24	91	126	161	197	232	267	268	-	268
26	81	113	145	177	209	242	244	-	244
28	73	102	132	161	191	220	222	-	222
30	66	93	120	148	175	196	196	-	196

54 m Main boom · Hauptausleger · Flèche principale									
Radius Ausladung Portée									
	t	0	50	100	150	200	250	300	325
m	t	t	t	t	t	t	t	t	t
9	424	504	518	518	-	-	-	-	518
10	349	452	506	514	518	-	-	-	518
12	253	343	420	466	505	518	-	-	518
14	197	268	340	398	437	474	497	-	497
16	160	219	278	337	381	414	438	-	438
18	133	184	235	286	332	367	389	-	389
20	114	158	202	247	291	327	348	-	348
22	98	138	177	216	256	292	314	-	314
24	86	122	157	192	228	263	285	-	285
26	76	108	141	173	205	237	262	-	262
28	68	98	127	156	186	215	242	-	242
30	61	88	115	143	170	197	224	-	224
34	50	74	97	121	144	168	191	-	193
38	42	63	83	104	125	146	165	-	165
42	36	54	73	91	110	128	142	-	142
46	31	48	64	81	98	115	124	-	124

42 m Main boom · Hauptausleger · Flèche principale									
Radius Ausladung Portée									
	t	0	50	100	150	200	250	300	325
m	t	t	t	t	t	t	t	t	t
8	501	569	577	580	-	-	-	-	585
9	423	508	555	564	574	-	-	-	585
10	350	450	510	550	567	-	-	-	585
12	255	345	419	470	513	546	-	-	546
14	199	270	342	398	440	478	478	-	478
16	162	221	281	338	384	418	421	-	421
18	136	186	237	288	333	371	375	-	375
20	116	160	205	249	293	329	337	-	337
22	101	140	180	219	258	293	306	-	306
24	89	124	160	195	230	265	280	-	280
26	79	111	143	175	207	240	257	-	257
28	71	100	130	159	189	218	236	-	236
30	64	91	118	146	173	200	216	-	216
34	53	77	100	124	147	171	179	-	179
38	46	66	87	108	129	144	-	-	144

60 m Main boom · Hauptausleger · Flèche principale									
Radius Ausladung Portée									
	t	0	50	100	150	200	250	300	325
m	t	t	t	t	t	t	t	t	t
9	425	457	459	462	-	-	-	-	465
10	348	452	459	462	-	-	-	-	465
12	252	342	420	442	455	-	-	-	465
14	196	267	339	397	435	465	-	-	465
16	159	218	277	337	379	412	423	-	423
18	132	183	234	284	331	365	377	-	377
20	112	157	201	245	290	327	338	-	338
22	97	136	176	215	254	291	306	-	306
24	85	120	156	191	226	262	278	-	278
26	75	107	139	171	203	236	255	-	255
28	67	96	126	155	184	214	235	-	235
30	60	87	114	141	168	196	219	-	219
34	49	72	96	119	143	166	190	-	193
38	40	61	82	103	123	144	165	-	170
42	34	53	71	90	108	127	145	-	150
46	28	46	62	79	96	113	129	-	132
50	24	40	55	71	86	101	114	-	114
54	21	36	50	64	78	92	97	-	97

48 m Main boom · Hauptausleger · Flèche principale									
Radius Ausladung Portée									
	t	0	50	100	150	200	250	300	325
m	t	t	t	t	t	t	t	t	t
8	501	540	544	548	-	-	-	-	558
9	423	505	544	548	-	-	-	-	558
10	349	451	508	534	545	-	-	-	558
12	254	344	419	467	511	555	-	-	558
14	198	269	341	398	438	476	487	-	487
16	161	220	279	337	383	416	425	-	425
18	134	185	236	286	332	369	375	-	375
20	115	159	203	248	292	328	335	-	335
22	99	139	178	217	257	292	303	-	303
24	87	123	158	193	229	264	277	-	277
26	77	110	142	174	206	238	256	-	256
28	69	99	128	157	187	216	238	-	238
30	62	90	117	144	171	198	221	-	221
34	52	75	99	122	146	169	190	-	190
38	43	64	85	106	126	147	162	-	162
42	37	56	74	93	111	130	134	-	134

66 m Main boom · Hauptausleger · Flèche principale									
Radius Ausladung Portée									
	t	0	50	100	150	200	250	300	325
m	t	t	t	t	t	t	t	t	t
10	347	394	399	404	-	-	-	-	411
12	252	342	381	392	403	-	-	-	411
14	195	267	338	380	397	411	-	-	411
16	158	217	277	336	378	404	404	-	404
18	131	182	233	284	331	364	367	-	367
20	112	156	200	245	289	326	334	-	334
22	96	136	175	214	254	291	305	-	305
24	84	119	155	190	226	261	280	-	280
26	74	106	138	170	203	235	258	-	258
28	66	95	125	154	184	213	238	-	238
30	59	86	113	140	167	195	221	-	221
34	48	71	95	118	142	165	189	-	193
38	39	60	81	102	122	143	164	-	169
42	33	51	70	89	107	126	144	-	149
46	27	45	61	78	95	112	128	-	133
50	23	39	54	69	85	100	115	-	119
54	19	34	48	62	76	91	104	-	104
58	16	30	44	57	70	83	90	-	90

[MAIN MENUE](#)

[Inhalt](#)

[Contents](#)

[Contenu](#)

180 t + 60 t ZB



8,40 m

SL-Radius 15 m

360°

DIN/ISO

72 m Main boom · Hauptausleger · Flèche principale									
Radius Ausladung									
Portée	t	0	50	100	150	200	250	300	325
m	t	t	t	t	t	t	t	t	t
10	340	346	351	-	-	-	-	-	373
12	251	341	351	358	-	-	-	-	373
14	195	266	337	348	360	-	-	-	373
16	157	216	276	335	355	373	-	-	373
18	131	181	232	283	332	351	351	-	351
20	111	155	199	244	288	322	322	-	322
22	95	135	174	213	253	291	297	-	297
24	83	118	154	189	225	260	274	-	274
26	73	105	137	169	202	234	254	-	254
SSL	28	65	94	124	153	183	212	236	236
	30	58	85	112	139	166	194	220	220
	34	47	70	94	117	141	164	188	193
	38	38	59	80	100	121	142	163	168
	42	31	50	69	87	106	124	143	148
	46	26	43	60	77	93	110	127	132
	50	21	37	53	68	83	99	114	118
	54	17	32	47	61	75	89	103	104
	58	14	28	42	55	68	81	93	93
	62	12	25	38	50	62	74	83	83

84 m Main boom · Hauptausleger · Flèche principale									
Radius Ausladung									
Portée	t	0	50	100	150	200	250	300	325
m	t	t	t	t	t	t	t	t	t
12	249	270	273	-	-	-	-	-	281
14	192	264	268	272	-	-	-	-	281
16	155	214	263	268	274	-	-	-	281
18	128	179	230	265	272	281	-	-	281
20	108	153	197	241	266	276	-	-	276
22	93	132	172	211	250	267	267	-	267
24	81	116	151	187	222	258	258	-	258
26	71	103	135	167	199	231	248	-	248
28	62	92	121	151	180	209	237	-	237
SSL	30	55	82	110	137	164	191	218	223
	34	44	68	91	115	138	162	185	191
	38	35	56	77	98	119	139	160	166
	42	28	48	66	85	103	122	140	146
	46	22	40	57	74	91	107	124	130
	50	18	34	50	65	80	96	111	116
	54	14	29	44	58	72	86	100	105
	58	11	25	38	52	65	78	91	96
	62	8	21	34	47	59	71	83	87
	66	6	18	30	42	53	65	76	77
	70	-	15	27	38	49	60	69	69
	74	-	13	24	34	45	55	61	61

78 m Main boom · Hauptausleger · Flèche principale									
Radius Ausladung									
Portée	t	0	50	100	150	200	250	300	325
m	t	t	t	t	t	t	t	t	t
12	251	299	303	306	-	-	-	-	315
14	194	265	295	301	-	-	-	-	315
16	156	216	275	296	305	-	-	-	315
18	130	181	231	282	300	311	-	-	311
20	110	154	199	243	287	298	298	-	298
22	95	134	173	213	252	284	284	-	284
24	82	118	153	188	224	259	270	-	270
26	72	104	137	169	201	233	256	-	256
SSL	28	64	93	123	152	182	211	241	242
	30	57	84	111	138	166	193	220	225
	34	46	69	93	116	140	163	187	192
	38	37	58	79	100	120	141	162	168
	42	30	49	68	86	105	123	142	148
	46	24	42	59	76	92	109	126	132
	50	20	36	52	67	82	98	113	118
	54	16	31	46	60	74	88	102	107
	58	13	27	41	54	67	80	93	97
	62	10	23	36	49	61	73	85	87
	66	8	20	32	44	55	67	77	77
	70	6	18	29	40	51	62	67	67

Remarks · Bemerkungen · Remarques

Superlift mast · Superlift-Mast · Mât Superlift 30 m

MAIN MENU



Inhalt



Contents



Contenu



# Lifting capacities main boom with Superlift Tragfähigkeiten Hauptausleger mit Superlift Capacités de levage flèche principale avec Superlift

180 t + 60 t ZB   8,40 m SL-Radius 15 m 360° DIN/ISO

90 m Main boom · Hauptausleger · Flèche principale									
Radius Ausladung  									
Portée	t	0	50	100	150	200	250	300	325
m	t								
12		239	239	240	-	-	-	-	248
14		199	239	240	243	-	-	-	248
16		161	221	240	243	-	-	-	248
18		135	185	236	243	245	-	-	248
20		115	159	203	242	244	-	-	246
22		99	138	178	217	237	241	-	241
24		87	122	157	193	228	235	-	235
26		77	109	141	173	205	230	230	230
28		68	98	127	156	186	215	224	224
30		61	88	115	143	170	197	212	212
34		50	73	97	120	144	167	191	191
SSL / LSL		38	41	62	83	103	124	145	165
		42	34	53	71	90	109	127	146
		46	28	46	62	79	96	113	129
		50	24	40	55	70	86	101	116
		54	20	35	49	63	77	91	105
		58	16	30	44	57	70	83	96
		62	13	26	39	51	63	75	88
		66	11	23	35	47	58	69	79
		70	9	20	32	42	53	64	72
		74	7	18	28	39	49	59	67
		78	6	16	26	36	45	55	62

102 m Main boom · Hauptausleger · Flèche principale									
Radius Ausladung  									
Portée	t	0	50	100	150	200	250	300	325
m	t								
14		173	175	176	-	-	-	-	181
16		161	174	174	-	-	-	-	179
18		134	172	173	174	-	-	-	178
20		114	158	171	172	-	-	-	176
22		99	138	169	171	-	-	-	174
24		86	122	157	169	171	-	-	172
26		76	108	140	168	169	-	-	170
28		68	97	126	156	167	168	-	168
30		61	88	115	142	165	166	-	166
34		49	73	96	120	143	156	-	156
38		41	61	82	103	123	144	145	145
SSL / LSL		42	33	52	71	89	108	126	134
		46	28	45	62	79	95	112	124
		50	23	39	54	70	85	100	114
		54	19	34	48	62	76	90	104
		58	15	29	43	56	69	82	95
		62	12	25	38	50	63	75	87
		66	10	22	34	46	57	68	80
		70	8	19	30	42	52	63	73
		74	6	17	27	38	48	58	68
		78	4	14	24	35	44	54	63
		82	-	12	22	31	41	50	59
		86	-	11	20	29	38	46	54
		90	-	9	18	26	35	43	48

96 m Main boom · Hauptausleger · Flèche principale									
Radius Ausladung  									
Portée	t	0	50	100	150	200	250	300	325
m	t								
12		207	207	208	-	-	-	-	215
14		199	206	207	-	-	-	-	214
16		161	204	206	209	-	-	-	213
18		134	185	205	208	-	-	-	212
20		114	159	203	207	209	-	-	211
22		99	138	177	204	206	-	-	209
24		86	122	157	193	202	205	-	205
26		76	108	141	173	198	202	-	202
28		68	97	127	156	186	199	199	199
30		61	88	115	142	169	194	194	194
SSL / LSL		34	50	73	96	120	143	167	178
		38	41	62	82	103	124	144	163
		42	34	53	71	90	108	127	145
		46	28	45	62	79	96	112	129
		50	23	39	55	70	85	101	116
		54	19	34	48	63	77	91	105
		58	16	30	43	56	69	82	95
		62	13	26	39	51	63	75	87
		66	11	23	35	46	57	69	80
		70	8	20	31	42	53	63	74
		74	6	17	28	38	48	58	68
		78	5	15	25	35	45	54	64
		82	-	13	23	32	41	50	58

108 m Main boom · Hauptausleger · Flèche principale									
Radius Ausladung  									
Portée	t	0	50	100	150	200	250	300	325
m	t								
14		147	147	-	-	-	-	-	153
16		143	144	145	-	-	-	-	150
18		133	140	142	-	-	-	-	147
20		113	137	139	-	-	-	-	145
22		98	134	137	139	-	-	-	142
24		85	121	134	137	-	-	-	139
26		75	107	131	134	-	-	-	136
28		67	96	125	131	132	-	-	133
30		60	87	114	128	129	-	-	130
34		48	72	95	119	123	-	-	124
SSL / LSL		38	39	60	81	102	117	119	-
		42	32	51	70	88	107	114	-
		46	26	44	61	77	94	108	108
		50	22	38	53	69	84	99	103
		54	18	32	47	61	75	89	98
		58	14	28	42	55	68	81	93
		62	11	24	37	49	61	74	86
		66	9	21	33	45	56	67	79
		70	6	18	29	40	51	62	72
		74	5	15	26	37	47	57	67
		78	-	13	23	33	43	53	62
		82	-	11	21	30	40	49	58
		86	-	9	18	27	37	45	54
		90	-	8	16	25	34	42	49
		94	-	6	14	23	31	39	44

Remarks · Bemerkungen · Remarques

Superlift mast · Superlift-Mast · Mât Superlift 30 m

[MAIN MENUE](#)

[Inhalt](#)

[Contents](#)

[Contenu](#)

180 t + 60 t ZB



8,40 m

SL-Radius 15 m

360°

DIN/ISO

114 m Main boom · Hauptausleger · Flèche principale									
Radius Ausladung									
Portée	t	0	50	100	150	200	250	300	325
m	t	t	t	t	t	t	t	t	t
14	129	129	-	-	-	-	-	-	134
16	126	127	-	-	-	-	-	-	132
18	124	125	126	-	-	-	-	-	131
20	113	124	125	-	-	-	-	-	129
22	97	122	123	-	-	-	-	-	127
24	85	120	122	123	-	-	-	-	126
26	75	107	120	122	-	-	-	-	124
28	66	96	119	120	-	-	-	-	122
30	59	86	114	119	120	-	-	-	120
34	48	71	95	116	116	-	-	-	117
38	39	60	81	101	111	113	-	-	113
42	32	51	69	88	106	108	-	-	108
46	26	44	60	77	94	104	-	-	104
SSL / LSL	21	37	53	68	83	99	99	99	99
54	17	32	47	61	75	89	95	95	95
58	14	28	41	54	67	80	91	91	91
62	11	24	37	49	61	73	85	86	86
66	8	20	32	44	55	67	78	82	82
70	6	17	29	40	51	61	72	76	76
74	4	15	25	36	46	56	66	70	70
78	-	12	23	33	43	52	62	65	65
82	-	10	20	30	39	48	57	59	59
86	-	9	18	27	36	45	53	55	55
90	-	7	16	24	33	42	50	50	50
94	-	5	14	22	30	39	45	45	45
98	-	4	12	20	28	36	41	41	41

126 m Main boom · Hauptausleger · Flèche principale									
Radius Ausladung									
Portée	t	0	50	100	150	200	250	300	325
m	t	t	t	t	t	t	t	t	t
16	106	106	-	-	-	-	-	-	109
18	104	105	-	-	-	-	-	-	108
20	103	104	105	-	-	-	-	-	108
22	97	103	104	-	-	-	-	-	107
24	85	102	103	-	-	-	-	-	106
26	74	101	102	103	-	-	-	-	105
28	66	95	102	103	-	-	-	-	104
30	59	86	101	102	-	-	-	-	103
34	47	71	94	100	101	-	-	-	101
38	38	59	80	98	99	-	-	-	99
42	31	50	69	87	96	97	-	-	97
46	25	43	60	77	93	94	-	-	94
50	20	37	52	68	83	91	-	-	91
SSL / LSL	16	31	46	60	74	88	88	88	88
58	13	27	41	54	67	80	85	85	85
62	10	23	36	48	60	72	82	82	82
66	7	19	32	43	55	66	77	79	79
70	5	16	28	39	50	61	71	73	73
74	-	14	25	35	46	56	66	68	68
78	-	12	22	32	42	51	61	63	63
82	-	9	19	29	38	47	56	59	59
86	-	8	17	26	35	44	52	54	54
90	-	6	15	23	32	41	49	50	50
94	-	4	13	21	29	38	46	46	46
98	-	-	11	19	27	35	42	42	42
102	-	-	9	17	25	32	39	39	39
106	-	-	8	15	23	30	35	35	35
110	-	-	7	14	21	28	32	32	32

120 m Main boom · Hauptausleger · Flèche principale									
Radius Ausladung									
Portée	t	0	50	100	150	200	250	300	325
m	t	t	t	t	t	t	t	t	t
14	119	119	-	-	-	-	-	-	122
16	117	117	-	-	-	-	-	-	121
18	115	116	116	-	-	-	-	-	120
20	112	114	115	-	-	-	-	-	118
22	97	113	114	-	-	-	-	-	117
24	85	111	112	-	-	-	-	-	115
26	75	107	111	112	-	-	-	-	114
28	66	96	109	111	-	-	-	-	112
30	59	86	108	109	-	-	-	-	111
34	48	71	95	105	106	-	-	-	107
38	39	60	80	101	103	-	-	-	104
42	32	51	69	88	99	100	-	-	100
SSL / LSL	26	43	60	77	94	97	-	-	97
50	21	37	53	68	83	93	93	93	93
54	17	32	46	60	75	89	90	90	90
58	13	27	41	54	67	80	86	86	86
62	10	23	36	49	61	73	82	82	82
66	8	20	32	44	55	67	78	79	79
70	6	17	28	40	50	61	72	75	75
74	4	14	25	36	46	56	66	69	69
78	-	12	22	32	42	52	61	64	64
82	-	10	20	29	39	48	57	59	59
86	-	8	17	26	35	44	53	54	54
90	-	7	15	24	33	41	49	50	50
94	-	5	13	22	30	38	46	46	46
98	-	4	12	20	28	36	42	42	42
102	-	-	10	18	25	33	38	38	38
106	-	-	9	16	23	31	34	34	34

132 m Main boom · Hauptausleger · Flèche principale									
Radius Ausladung									
Portée	t	0	50	100	150	200	250	300	325
m	t	t	t	t	t	t	t	t	t
16	92	92	-	-	-	-	-	-	96
18	90	91	-	-	-	-	-	-	95
20	88	89	-	-	-	-	-	-	94
22	87	88	89	-	-	-	-	-	93
24	84	87	88	-	-	-	-	-	92
26	73	86	87	-	-	-	-	-	91
28	65	85	86	-	-	-	-	-	90
30	58	84	86	87	-	-	-	-	89
34	46	70	84	86	-	-	-	-	87
38	37	58	79	85	85	-	-	-	86
42	30	49	68	83	84	-	-	-	85
46	24	42	59	76	82	83	-	-	83
SSL / LSL	19	36	51	67	80	82	-	-	82
54	15	30	45	59	73	80	-	-	80
58	12	26	39	53	66	78	78	78	78
62	9	22	35	47	59	71	75	75	75
66	6	18	30	42	54	65	73	73	73
70	4	15	27	38	49	60	70	70	70
74	-	13	23	34	45	55	65	66	66
78	-	10	20	31	41	50	60	61	61
82	-	8	18	27	37	46	55	57	57
86	-	6	16	25	34	43	51	52	52
90	-	5	13	22	31	39	48	49	49
94	-	-	12	20	28	36	45	45	45
98	-	-	10	18	26	34	41	41	41
102	-	-	8	16	23	31	38	38	38
106	-	-	7	14	21	29	35	35	35
110	-	-	6	13	20	27	30	30	30
114	-	-	4	11	18	25	25	25	25

MAIN MENUE



Inhalt

Contents

Contenu

# Lifting capacities main boom with Superlift Tragfähigkeiten Hauptausleger mit Superlift Capacités de levage flèche principale avec Superlift

180 t + 60 t ZB   8,40 m SL-Radius 15 m 360° DIN/ISO

138 m Main boom · Hauptausleger · Flèche principale									
Radius									
Ausladung									
Portée		0	50	100	150	200	250	275	
t	t	t	t	t	t	t	t	t	
m	t	t	t	t	t	t	t	t	
16		79	79	-	-	-	-	82	
18		77	77	-	-	-	-	80	
20		74	75	-	-	-	-	79	
22		72	74	-	-	-	-	78	
24		70	72	73	-	-	-	77	
26		69	71	72	-	-	-	75	
28		64	70	71	-	-	-	74	
30		57	68	70	-	-	-	73	
34		46	66	67	69	-	-	71	
38		36	58	65	67	-	-	68	
42		29	49	63	64	-	-	66	
46		23	41	58	62	62	-	63	
50		18	35	51	59	60	-	61	
SSL / LSL		14	29	44	56	57	-	58	
58		11	25	39	52	54	55	55	
62		8	21	34	47	51	52	52	
66		5	17	29	42	48	49	49	
70		-	14	26	37	44	46	46	
74		-	12	22	33	41	42	42	
78		-	9	20	30	38	39	39	
82		-	7	17	27	35	36	36	
86		-	6	15	24	31	32	32	
90		-	4	13	21	28	28	28	
94		-	-	11	19	24	25	25	
98		-	-	9	17	20	21	21	
102		-	-	7	15	17	17	17	
106		-	-	6	13	13	13	13	
110		-	-	5	9	9	9	9	

## Remarks · Bemerkungen · Remarques

Superlift mast · Superlift-Mast · Mât Superlift 30 m

[MAIN MENU](#)

[Inhalt](#)

[Contents](#)

[Contenu](#)

# Notes to lifting capacity

## Anmerkungen zu den Tragfähigkeiten

### Conditions d'utilisation

Ratings are in compliance with ISO 4305 and DIN 15019.2 (test load = 1.25 x suspended load + 0.1 x dead weight of boom, reduced to boom point).

Weight of hook blocks and slings is part of the load, and is to be deducted from the capacity ratings.

Crane operation is permissible up to a

wind pressure of ..... 60 N/m<sup>2</sup>

wind speed of ..... 9.8 m/s

Consult operation manual for further details on wind speed.

Machine must be on firm and level ground to utilize max. tabulated ratings. Boom lengths and load must be reduced in case of out-of-level conditions or travel on uneven ground.

Note: Data published herein is intended as a guide only and shall not be construed to warrant applicability for lifting purposes.

Crane operation is subject to the computer charts and operation manual both supplied with the crane.

---

Tragfähigkeiten entsprechen ISO 4305 und DIN 15019.2 (Prüflast = 1,25 x Hublast + 0,1 x Auslegereigengewicht, auf die Auslegerspitze reduziert).

Das Gewicht der Unterflaschen sowie die Aufnahmemittel sind Bestandteile der Last und sind von den Tragfähigkeiten abzuziehen.

Kranbetrieb zulässig bis

Staudruck ..... 60 N/m<sup>2</sup>

Windgeschwindigkeit ..... 9,8 m/s

Weitere Angaben über Windgeschwindigkeiten sind der Bedienungsanleitung des Kranes zu entnehmen.

Die Ausnutzung der maximalen Tragfähigkeit nach der Tabelle setzt eine völlig ebene und tragfähige Aufstandsfläche voraus.

Bei Schräglage und Fahren über unebenes Gelände sind Auslegerlängen und Last zu reduzieren.

Anmerkung: Die Daten dieser Broschüre dienen nur zur allgemeinen Information; für ihre Richtigkeit übernehmen wir keine Haftung.

Der Betrieb des Kranes ist nur mit den Original-Tragfähigkeitstabellen und mit der Bedienungsanleitung zulässig, die mit dem Kran mitgeliefert werden.

---

Le tableau de charges est conforme à la norme ISO 4305 et DIN 15019.2 (charge d'essai = 1,25 x charge suspendue + 0,1 x poids mort de la flèche, réduit à la pointe de flèche).

Les poids du crochet-moufle et de tous les accessoires d'élingage font partie de la charge et sont à déduire des charges indiquées.

La grue peut travailler jusqu'à une

pression du vent de ..... 60 N/m<sup>2</sup>

vitesse du vent de ..... 9,8 m/s

Pour plus de détails sur les vitesses du vent consulter la notice d'utilisation de la grue.

L'utilisation de la capacité maxi nécessite une opération sur sol ferme et horizontal. En cas de travail sous un dévers ou en cas de déplacements dans un terrain irrégulier, les longueurs de flèche et les charges maxima admissibles sont à réduire.

Nota: Les renseignements ci-inclus sont donnés à titre indicatif et ne représentent aucune garantie d'utilisation pour les opérations de levage. La mise en service de la grue n'est autorisée qu'à condition que les tableaux de charges ainsi que le manuel de service, tels que fournis avec la grue, soient observés.

[MAIN MENU](#)

[Inhalt](#)

[Contents](#)

[Contenu](#)

# Working ranges main boom with Superlift Arbeitsbereiche Hauptausleger mit Superlift Portées de flèche principale avec Superlift

SSL, SSL/LSL

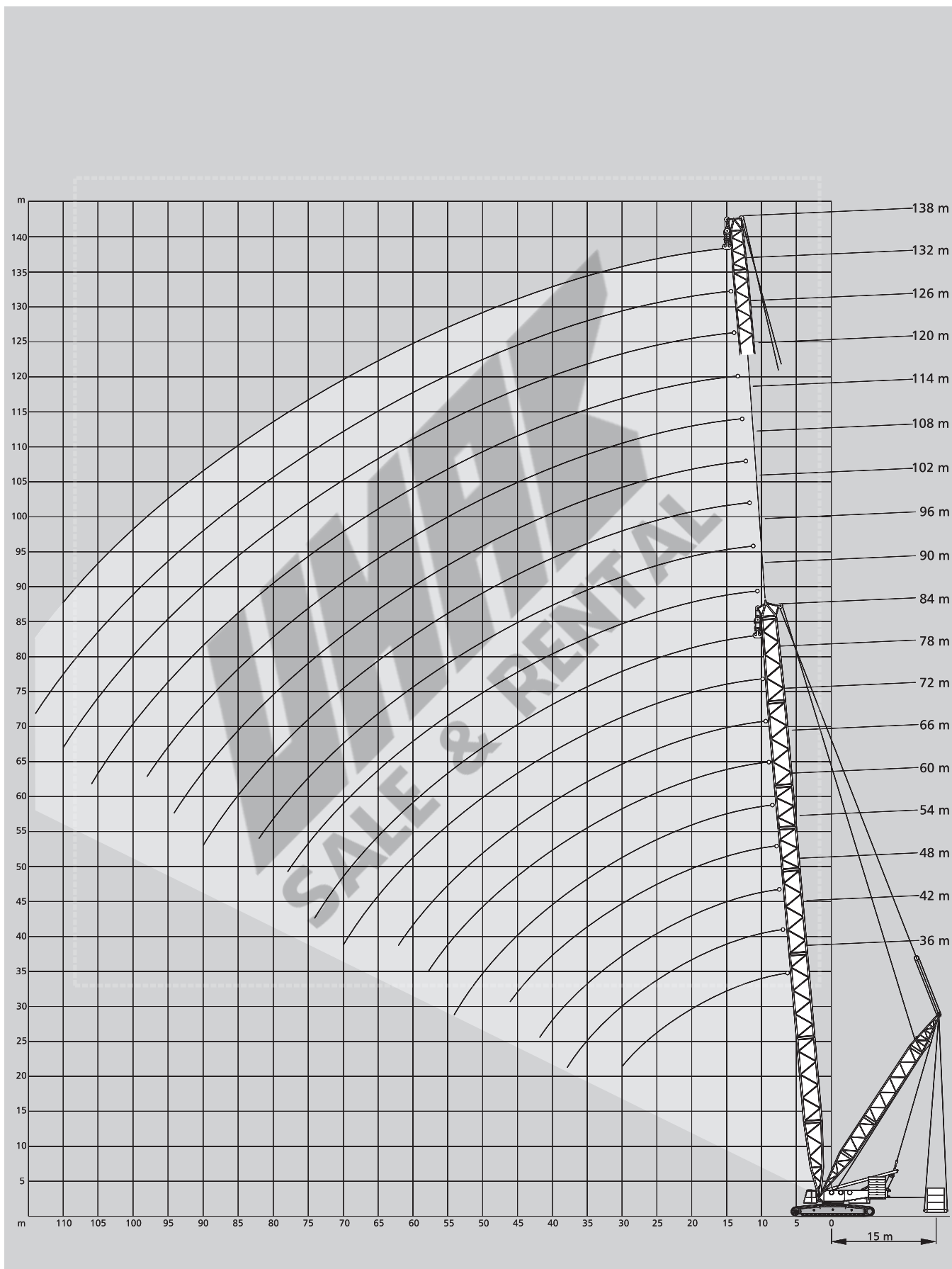

[MAIN MENUE](#)

[Inhalt](#)

[Contents](#)

[Contenu](#)



# Working ranges fixed fly jib 10°

## Arbeitsbereiche starrer Hilfsausleger 10°

### Portées fléchette fixe 10°

LF, SH/LH + LF

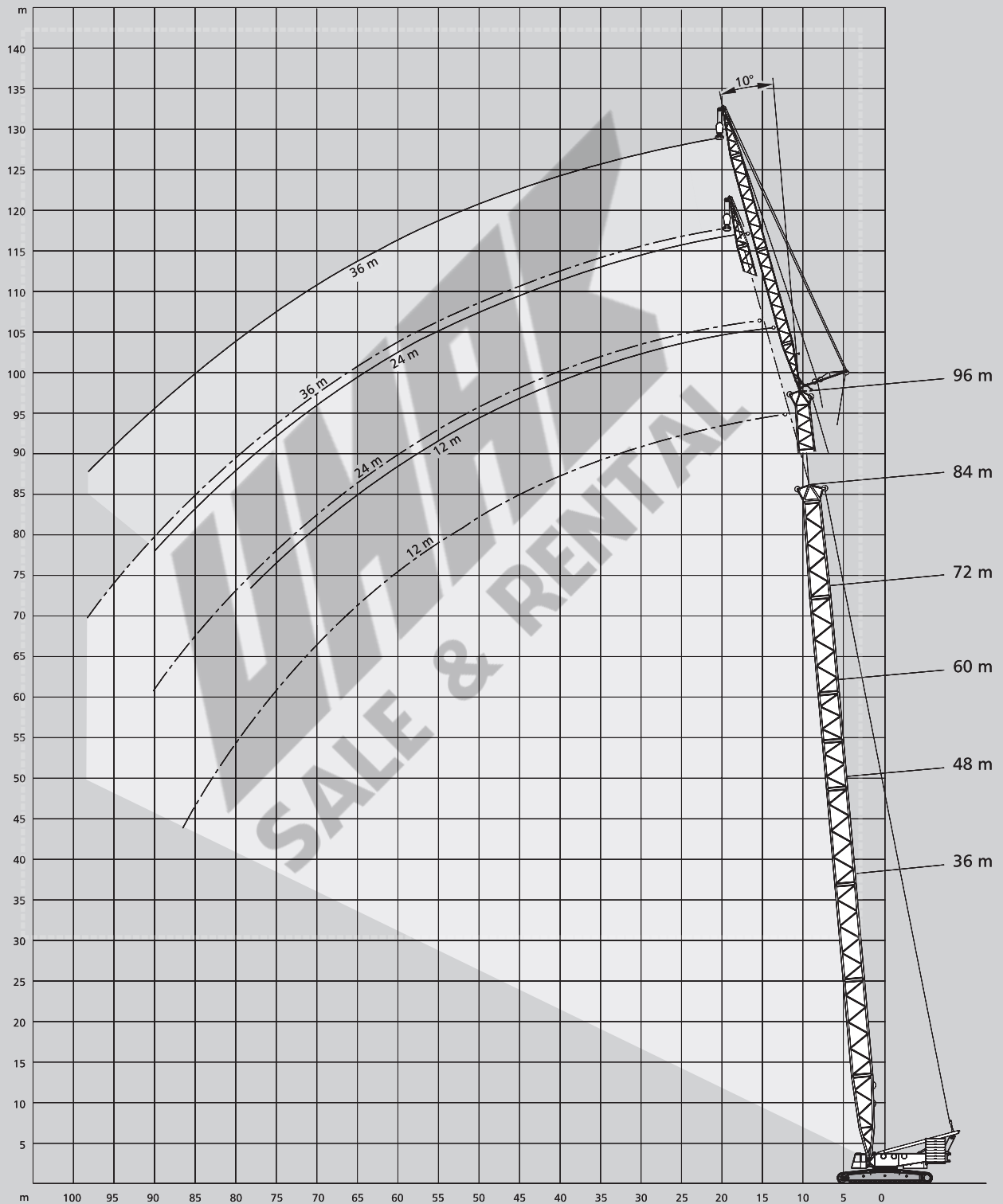

[MAIN MENU](#)

[Inhalt](#)

[Contents](#)

[Contenu](#)



# Lifting capacities fixed fly jib

## Tragfähigkeiten starrer Hilfsausleger

### Capacités de levage fléchette fixe

180 t + 60 t ZB



8,40 m

360°

DIN/ISO

36 m Main boom · Hauptausleger · Flèche principale							
Radius Ausladung Portée	Fly jib · Hilfsausleger · Fléchette						
	12 m		24 m		36 m		
	10°	30°	10°	30°	10°	30°	
m	t	t	t	t	t	t	
9	80,0	-	-	-	-	-	
10	80,0	-	-	-	-	-	
12	80,0	-	-	-	-	-	
14	78,0	38,0	46,0	-	-	-	
16	70,0	36,0	41,0	-	32,0	-	
18	63,0	34,0	37,0	-	29,0	-	
20	57,0	32,0	34,0	20,0	26,0	-	
22	52,0	30,0	31,0	19,0	24,0	-	
24	49,0	29,0	29,0	18,0	22,0	-	
26	45,0	28,0	27,0	17,0	20,0	-	
28	42,0	27,0	25,0	16,0	19,0	12,0	
30	40,0	26,0	23,0	16,0	17,0	12,0	
34	35,0	24,0	21,0	14,0	15,0	11,0	
38	32,0	23,0	18,0	13,0	13,0	10,0	
42	29,0	-	17,0	12,0	12,0	9,0	
46	-	-	15,0	12,0	11,0	8,0	
50	-	-	14,0	11,0	10,0	8,0	
54	-	-	13,0	-	9,0	7,0	
58	-	-	-	-	8,0	7,0	
62	-	-	-	-	8,0	6,0	
66	-	-	-	-	7,0	-	
70	-	-	-	-	-	-	
74	-	-	-	-	-	-	
78	-	-	-	-	-	-	
82	-	-	-	-	-	-	

LF

60 m Main boom · Hauptausleger · Flèche principale							
Radius Ausladung Portée	Fly jib · Hilfsausleger · Fléchette						
	12 m		24 m		36 m		
	10°	30°	10°	30°	10°	30°	
m	t	t	t	t	t	t	
12	80,0	-	-	-	-	-	
14	80,0	-	-	-	-	-	
16	80,0	38,0	48,0	-	-	-	
18	80,0	37,0	44,0	-	29,0	-	
20	74,0	35,0	40,0	-	29,0	-	
22	69,0	34,0	37,0	20,0	28,0	-	
24	64,0	33,0	35,0	19,0	26,0	-	
26	60,0	32,0	33,0	18,0	24,0	-	
28	56,0	31,0	31,0	18,0	23,0	-	
30	53,0	30,0	29,0	17,0	21,0	12,0	
34	48,0	28,0	26,0	16,0	19,0	11,0	
38	44,0	27,0	24,0	15,0	17,0	10,0	
42	38,0	25,0	22,0	14,0	15,0	10,0	
46	33,0	24,0	20,0	13,0	14,0	9,0	
50	28,0	23,0	18,0	13,0	13,0	9,0	
54	25,0	23,0	17,0	12,0	12,0	8,0	
58	21,0	-	16,0	12,0	11,0	8,0	
62	19,0	-	15,0	11,0	10,0	7,0	
66	-	-	14,0	11,0	9,0	7,0	
70	-	-	14,0	-	9,0	7,0	
74	-	-	13,0	-	8,0	6,0	
78	-	-	-	-	8,0	6,0	
82	-	-	-	-	7,0	-	
86	-	-	-	-	7,0	-	
90	-	-	-	-	-	-	

LF

48 m Main boom · Hauptausleger · Flèche principale						
m	t					
	t	t	t	t	t	t
10	80,0	-	-	-	-	-
12	80,0	-	-	-	-	-
14	80,0	39,0	49,0	-	-	-
16	79,0	37,0	45,0	-	31,0	-
18	72,0	35,0	41,0	-	30,0	-
20	66,0	34,0	37,0	-	28,0	-
22	61,0	32,0	34,0	20,0	26,0	-
24	57,0	31,0	32,0	19,0	24,0	-
26	53,0	30,0	30,0	18,0	22,0	-
28	50,0	29,0	28,0	17,0	21,0	13,0
30	47,0	28,0	26,0	16,0	19,0	12,0
34	42,0	26,0	23,0	15,0	17,0	11,0
38	38,0	25,0	21,0	14,0	15,0	10,0
42	35,0	24,0	19,0	13,0	14,0	9,0
46	32,0	23,0	18,0	13,0	12,0	9,0
50	30,0	-	16,0	12,0	11,0	8,0
54	27,0	-	15,0	12,0	10,0	8,0
58	-	-	14,0	11,0	10,0	7,0
62	-	-	13,0	-	9,0	7,0
66	-	-	13,0	-	8,0	7,0
70	-	-	-	-	8,0	6,0
74	-	-	-	-	7,0	-
78	-	-	-	-	-	-
82	-	-	-	-	-	-
86	-	-	-	-	-	-
90	-	-	-	-	-	-
94	-	-	-	-	-	-

LF

72 m Main boom · Hauptausleger · Flèche principale						
m	t					
	t	t	t	t	t	t
12	80,0	-	-	-	-	-
14	80,0	-	-	-	-	-
16	80,0	39,0	50,0	-	-	-
18	80,0	37,0	46,0	-	-	-
20	80,0	36,0	43,0	-	29,0	-
22	75,0	35,0	40,0	-	28,0	-
24	70,0	34,0	37,0	19,0	27,0	-
26	66,0	33,0	35,0	19,0	25,0	-
28	62,0	32,0	33,0	18,0	24,0	-
30	59,0	31,0	31,0	18,0	23,0	12,0
34	50,0	29,0	28,0	16,0	20,0	12,0
38	42,0	28,0	26,0	16,0	18,0	11,0
42	36,0	27,0	24,0	15,0	17,0	10,0
46	30,0	26,0	22,0	14,0	15,0	9,0
50	26,0	25,0	20,0	13,0	14,0	9,0
54	22,0	23,0	19,0	13,0	13,0	8,0
58	19,0	20,0	18,0	12,0	12,0	8,0
62	16,0	17,0	17,0	12,0	11,0	8,0
66	13,0	-	15,0	11,0	10,0	7,0
70	11,0	-	13,0	11,0	10,0	7,0
74	9,0	-	11,0	11,0	9,0	7,0
78	-	-	9,0	-	9,0	6,0
82	-	-	8,0	-	8,0	6,0
86	-	-	7,0	-	8,0	6,0
90	-	-	-	-	7,0	-
94	-	-	-	-	5,0	-
98	-	-	-	-	4,0	-

LF

MAIN MENU

Inhalt

Contents

Contenu



84 m Main boom · Hauptausleger · Flèche principale							
Radius Ausladung Portée	Fly jib · Hilfsausleger · Fléchette						
	12 m		24 m		36 m		
	10°	30°	10°	30°	10°	30°	
m	t	t	t	t	t	t	
14	80,0	-	-	-	-	-	
16	80,0	-	-	-	-	-	
18	80,0	38,0	48,0	-	-	-	
20	80,0	37,0	45,0	-	29,0	-	
22	80,0	36,0	42,0	-	28,0	-	
24	76,0	35,0	40,0	20,0	27,0	-	
26	72,0	34,0	37,0	19,0	26,0	-	
28	66,0	33,0	35,0	18,0	25,0	-	
30	59,0	32,0	34,0	18,0	24,0	-	
34	48,0	30,0	30,0	17,0	22,0	12,0	
38	40,0	29,0	28,0	16,0	19,0	11,0	
42	34,0	28,0	26,0	15,0	18,0	10,0	
46	28,0	27,0	24,0	14,0	16,0	10,0	
LF	50	23,0	25,0	22,0	14,0	15,0	9,0
	54	19,0	21,0	21,0	13,0	14,0	9,0
	58	16,0	17,0	18,0	13,0	13,0	8,0
	62	13,0	14,0	15,0	12,0	12,0	8,0
	66	11,0	12,0	13,0	12,0	11,0	7,0
	70	9,0	9,0	11,0	12,0	11,0	7,0
	74	7,0	-	9,0	10,0	10,0	7,0
	78	5,0	-	7,0	8,0	8,0	7,0
	82	3,0	-	5,0	6,0	7,0	6,0
	86	2,0	-	4,0	-	5,0	6,0
	90	-	-	3,0	-	4,0	5,0
	94	-	-	-	-	3,0	4,0
	98	-	-	-	-	2,0	-
	102	-	-	-	-	-	-
	106	-	-	-	-	-	-
	110	-	-	-	-	-	-

84 m Main boom · Hauptausleger · Flèche principale							
Radius Ausladung Portée	Fly jib · Hilfsausleger · Fléchette						
	12 m		24 m		36 m		
	10°	30°	10°	30°	10°	30°	
m	t	t	t	t	t	t	
14	80,0	-	-	-	-	-	
16	80,0	-	-	-	-	-	
18	80,0	40,0	50,0	-	-	-	
20	80,0	38,0	47,0	-	28,0	-	
22	80,0	37,0	45,0	-	28,0	-	
24	78,0	36,0	43,0	20,0	27,0	-	
26	74,0	35,0	40,0	20,0	26,0	-	
28	68,0	34,0	38,0	19,0	25,0	-	
30	61,0	33,0	36,0	19,0	24,0	-	
34	51,0	31,0	32,0	17,0	23,0	12,0	
38	42,0	30,0	29,0	17,0	21,0	11,0	
42	36,0	29,0	27,0	16,0	19,0	11,0	
46	30,0	27,0	25,0	15,0	17,0	10,0	
SH/LH + LF	50	26,0	26,0	23,0	14,0	16,0	9,0
	54	22,0	23,0	21,0	14,0	15,0	9,0
	58	19,0	20,0	20,0	13,0	13,0	8,0
	62	16,0	17,0	18,0	13,0	13,0	8,0
	66	13,0	14,0	15,0	12,0	12,0	8,0
	70	11,0	12,0	13,0	12,0	11,0	7,0
	74	9,0	10,0	11,0	11,0	10,0	7,0
	78	8,0	-	9,0	10,0	10,0	7,0
	82	6,0	-	8,0	9,0	9,0	7,0
	86	5,0	-	6,0	-	7,0	6,0
	90	-	-	5,0	-	6,0	6,0
	94	-	-	4,0	-	5,0	6,0
	98	-	-	3,0	-	4,0	-
	102	-	-	-	-	3,0	-
	106	-	-	-	-	2,0	-
	110	-	-	-	-	-	-

72 m Main boom · Hauptausleger · Flèche principale							
m	t	t	t	t	t	t	
	12	80,0	-	-	-	-	-
14	80,0	-	-	-	-	-	
16	80,0	40,0	50,0	-	-	-	
18	80,0	39,0	49,0	-	-	-	
20	80,0	37,0	46,0	-	28,0	-	
22	78,0	36,0	43,0	-	27,0	-	
24	73,0	35,0	40,0	20,0	26,0	-	
26	69,0	34,0	37,0	19,0	25,0	-	
28	65,0	33,0	35,0	19,0	24,0	-	
30	61,0	32,0	33,0	18,0	23,0	13,0	
34	52,0	30,0	30,0	17,0	21,0	12,0	
SH/LH + LF	38	44,0	29,0	27,0	16,0	19,0	11,0
	42	37,0	27,0	25,0	15,0	17,0	10,0
	46	32,0	26,0	23,0	14,0	16,0	10,0
	50	28,0	25,0	21,0	14,0	15,0	9,0
	54	24,0	24,0	20,0	13,0	13,0	9,0
	58	20,0	21,0	18,0	13,0	12,0	8,0
	62	18,0	18,0	17,0	12,0	11,0	8,0
	66	15,0	-	16,0	12,0	11,0	7,0
	70	13,0	-	15,0	11,0	10,0	7,0
	74	11,0	-	13,0	11,0	9,0	7,0
	78	-	-	11,0	-	9,0	7,0
	82	-	-	9,0	-	8,0	6,0
	86	-	-	8,0	-	8,0	6,0
	90	-	-	-	-	8,0	-
	94	-	-	-	-	7,0	-
	98	-	-	-	-	6,0	-

96 m Main boom · Hauptausleger · Flèche principale							
m	t	t	t	t	t	t	
	16	75,0	-	-	-	-	-
18	75,0	40,0	45,0	-	-	-	
20	75,0	39,0	45,0	-	-	-	
22	75,0	38,0	43,0	-	27,0	-	
24	75,0	37,0	42,0	-	27,0	-	
26	73,0	36,0	41,0	20,0	26,0	-	
28	67,0	35,0	40,0	19,0	25,0	-	
30	60,0	34,0	38,0	19,0	24,0	-	
34	49,0	32,0	34,0	18,0	22,0	12,0	
38	41,0	31,0	31,0	17,0	21,0	11,0	
42	34,0	30,0	29,0	16,0	19,0	11,0	
SH/LH + LF	46	29,0	28,0	27,0	15,0	18,0	10,0
	50	24,0	26,0	25,0	15,0	17,0	10,0
	54	20,0	21,0	22,0	14,0	16,0	9,0
	58	17,0	18,0	19,0	14,0	15,0	9,0
	62	14,0	15,0	16,0	13,0	14,0	8,0
	66	12,0	12,0	13,0	13,0	13,0	8,0
	70	9,0	10,0	11,0	12,0	12,0	8,0
	74	7,0	8,0	9,0	11,0	10,0	7,0
	78	6,0	6,0	7,0	9,0	8,0	7,0
	82	-	5,0	6,0	7,0	7,0	7,0
	86	-	-	4,0	5,0	5,0	7,0
	90	-	-	3,0	4,0	4,0	6,0
	94	-	-	-	3,0	3,0	4,0
	98	-	-	-	-	2,0	3,0
	102	-	-	-	-	-	2,0
	106	-	-	-	-	-	-

# Working ranges fixed fly jib 30°

## Arbeitsbereiche starrer Hilfsausleger 30°

### Portées fléchette fixe 30°

LF, SH/LH + LF

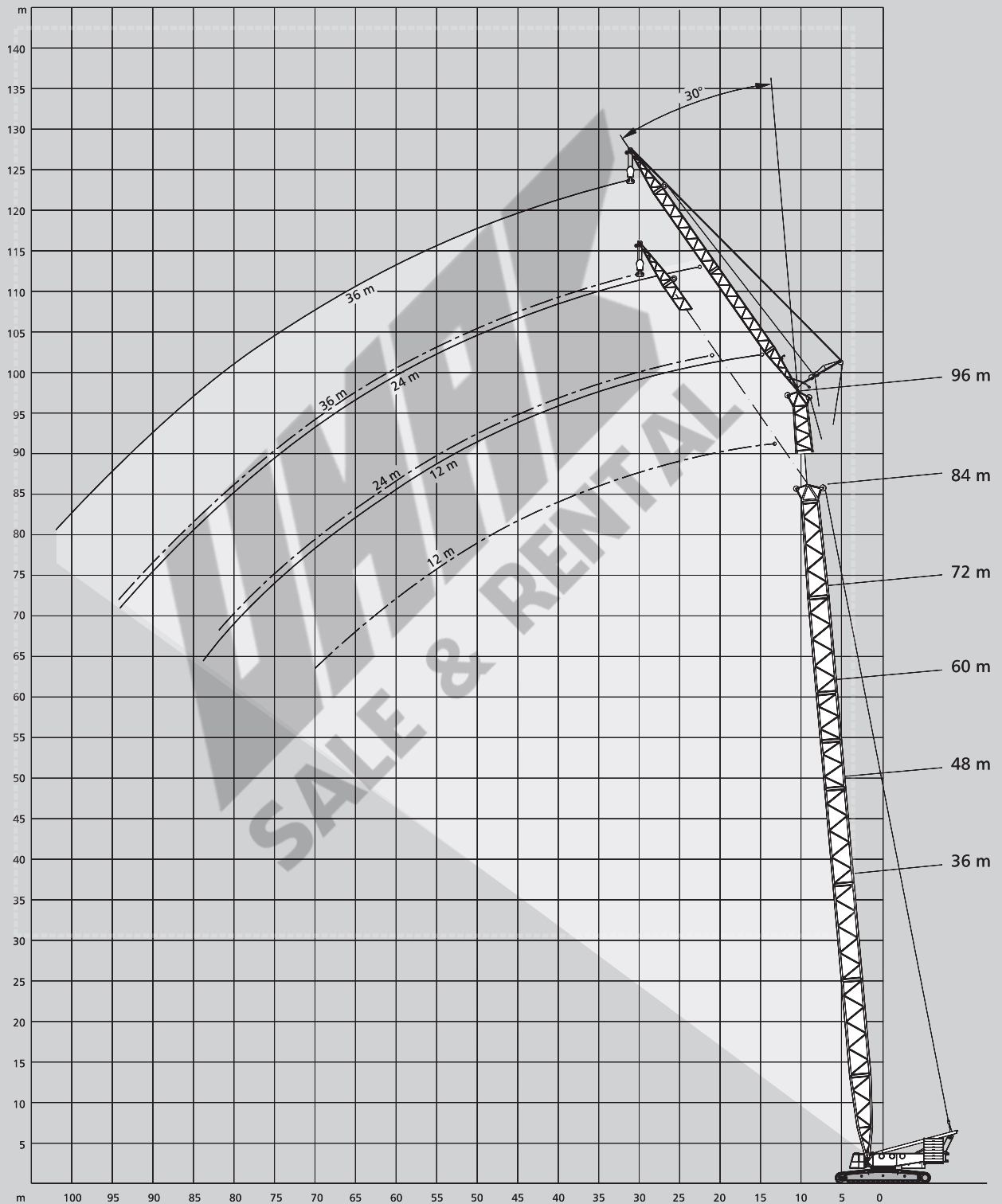

[MAIN MENUE](#)

[Inhalt](#)

[Contents](#)

[Contenu](#)

Working ranges fixed fly jib with SL, 10°  
 Arbeitsbereiche starrer Hilfsausleger mit SL, 10°  
 Portées fléchette fixe avec SL, 10°

SSL + LF, SSL/LSL + LF

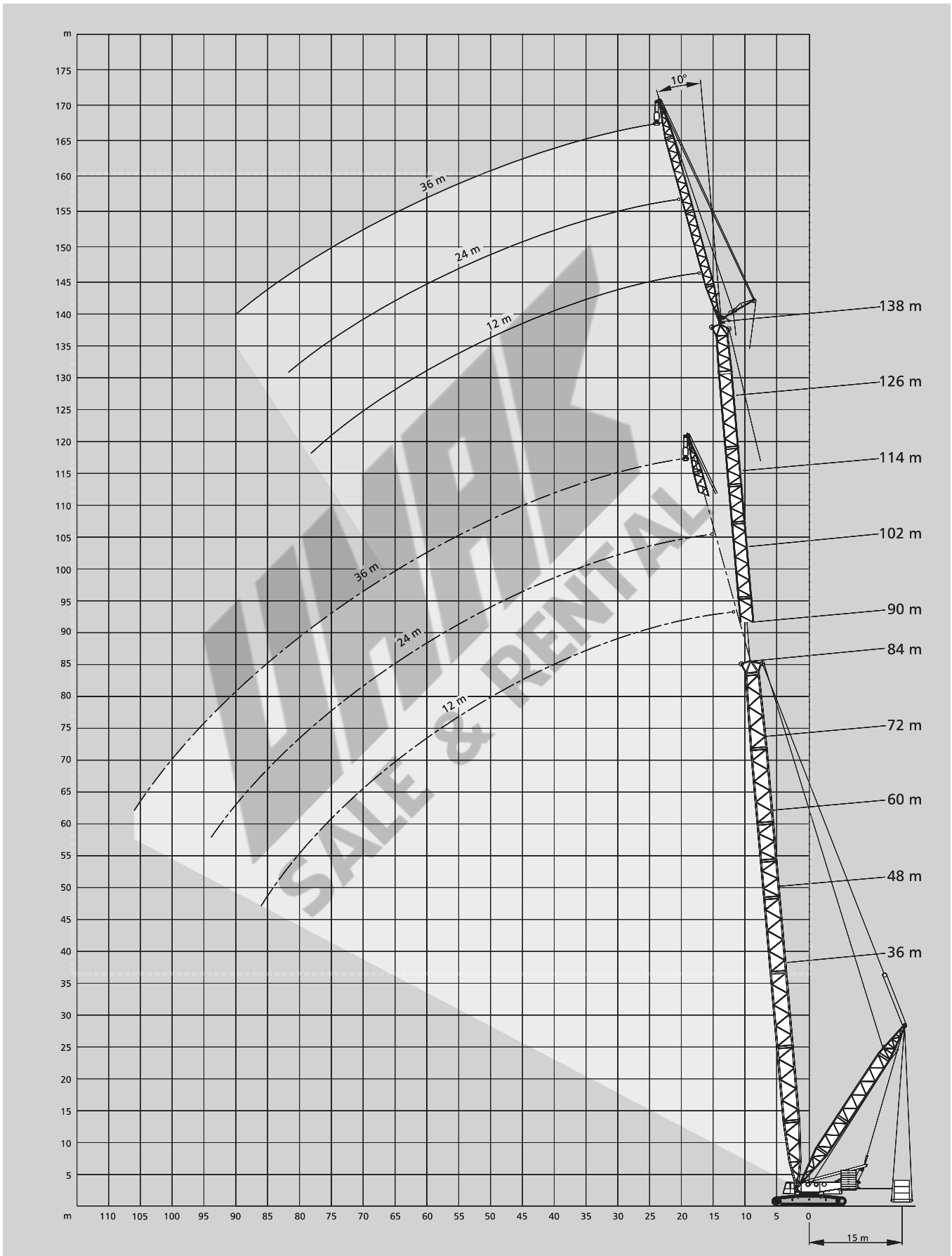

[MAIN MENUE](#)

[Inhalt](#)

[Contents](#)

[Contenu](#)

# Lifting capacities fixed fly jib with Superlift

## Tragfähigkeiten starrer Hilfsausleger mit Superlift

### Capacités de levage fléchette fixe avec Superlift

180 t + 60 t ZB  8,40 m SL-Radius 15 m 360° DIN/ISO

36 m Main boom · Hauptausleger · Flèche principale													
Radius Ausladung Portée	12 m				Fly jib · Hilfsausleger · Fléchette				36 m				
	10°		30°		10°		30°		10°		30°		
	0	75	0	75	0	75	0	75	0	75	0	75	
m	t	t	t	t	t	t	t	t	t	t	t	t	t
9	80,0	80,0	-	-	-	-	-	-	-	-	-	-	-
10	80,0	80,0	-	-	-	-	-	-	-	-	-	-	-
12	80,0	80,0	-	-	-	-	-	-	-	-	-	-	-
14	78,0	78,0	38,0	38,0	46,0	46,0	-	-	-	-	-	-	-
16	70,0	70,0	36,0	36,0	41,0	41,0	-	-	33,0	33,0	-	-	-
18	63,0	63,0	34,0	34,0	37,0	37,0	-	-	29,0	29,0	-	-	-
20	57,0	57,0	32,0	32,0	34,0	34,0	20,0	20,0	26,0	26,0	-	-	-
22	52,0	52,0	30,0	30,0	31,0	31,0	19,0	19,0	24,0	24,0	-	-	-
24	48,0	48,0	29,0	29,0	29,0	29,0	18,0	18,0	22,0	22,0	-	-	-
26	45,0	45,0	28,0	28,0	27,0	27,0	17,0	17,0	20,0	20,0	-	-	-
28	42,0	42,0	27,0	27,0	25,0	25,0	16,0	16,0	19,0	19,0	12,0	12,0	12,0
30	40,0	40,0	26,0	26,0	23,0	23,0	16,0	16,0	17,0	17,0	12,0	12,0	12,0
34	35,0	35,0	24,0	24,0	21,0	21,0	14,0	14,0	15,0	15,0	11,0	11,0	11,0
38	32,0	32,0	23,0	23,0	18,0	18,0	13,0	13,0	13,0	13,0	10,0	10,0	10,0
42	29,0	29,0	-	-	17,0	17,0	12,0	12,0	12,0	12,0	9,0	9,0	9,0
46	-	-	-	-	15,0	15,0	12,0	12,0	11,0	11,0	8,0	8,0	8,0
50	-	-	-	-	14,0	14,0	11,0	11,0	10,0	10,0	8,0	8,0	8,0
54	-	-	-	-	13,0	13,0	-	-	9,0	9,0	7,0	7,0	7,0
58	-	-	-	-	-	-	-	-	8,0	8,0	7,0	7,0	7,0
62	-	-	-	-	-	-	-	-	8,0	8,0	6,0	6,0	6,0
66	-	-	-	-	-	-	-	-	7,0	7,0	-	-	-

48 m Main boom · Hauptausleger · Flèche principale														
m	t		t		t		t		t		t		t	
	t	t	t	t	t	t	t	t	t	t	t	t	t	t
10	80,0	80,0	-	-	-	-	-	-	-	-	-	-	-	-
12	80,0	80,0	-	-	-	-	-	-	-	-	-	-	-	-
14	80,0	80,0	39,0	39,0	49,0	49,0	-	-	-	-	-	-	-	-
16	79,0	79,0	37,0	37,0	45,0	45,0	-	-	-	-	-	-	-	-
18	72,0	72,0	35,0	35,0	41,0	41,0	-	-	31,0	31,0	-	-	-	-
20	66,0	66,0	34,0	34,0	37,0	37,0	-	-	29,0	29,0	-	-	-	-
22	61,0	61,0	32,0	32,0	34,0	34,0	20,0	20,0	26,0	26,0	-	-	-	-
24	57,0	57,0	31,0	31,0	32,0	32,0	19,0	19,0	24,0	24,0	-	-	-	-
26	53,0	53,0	30,0	30,0	30,0	30,0	18,0	18,0	22,0	22,0	-	-	-	-
28	50,0	50,0	29,0	29,0	28,0	28,0	17,0	17,0	21,0	21,0	13,0	13,0	13,0	13,0
30	47,0	47,0	28,0	28,0	26,0	26,0	16,0	16,0	19,0	19,0	12,0	12,0	12,0	12,0
34	42,0	42,0	26,0	26,0	23,0	23,0	15,0	15,0	17,0	17,0	11,0	11,0	11,0	11,0
38	38,0	38,0	25,0	25,0	21,0	21,0	14,0	14,0	15,0	15,0	10,0	10,0	10,0	10,0
42	35,0	35,0	24,0	24,0	19,0	19,0	13,0	13,0	14,0	14,0	9,0	9,0	9,0	9,0
46	32,0	32,0	23,0	23,0	18,0	18,0	13,0	13,0	12,0	12,0	9,0	9,0	9,0	9,0
50	30,0	30,0	-	-	16,0	16,0	12,0	12,0	11,0	11,0	8,0	8,0	8,0	8,0
54	28,0	28,0	-	-	15,0	15,0	12,0	12,0	10,0	10,0	8,0	8,0	8,0	8,0
58	-	-	-	-	14,0	14,0	11,0	11,0	10,0	10,0	7,0	7,0	7,0	7,0
62	-	-	-	-	13,0	13,0	-	-	9,0	9,0	7,0	7,0	7,0	7,0
66	-	-	-	-	13,0	13,0	-	-	8,0	8,0	7,0	7,0	7,0	7,0
70	-	-	-	-	-	-	-	-	8,0	8,0	6,0	6,0	6,0	6,0
74	-	-	-	-	-	-	-	-	7,0	7,0	-	-	-	-
78	-	-	-	-	-	-	-	-	-	-	-	-	-	-

#### Remarks · Bemerkungen · Remarques

Superlift mast · Superlift-Mast · Mât Superlift 30 m

[MAIN MENUE](#)

[Inhalt](#)

[Contents](#)

[Contenu](#)

180 t + 60 t ZB



8,40 m

SL-Radius 15 m

360°

DIN/ISO

60 m		Main boom · Hauptausleger · Fleche principale								Fly jib · Hilfsausleger · Fléchette			
Radius Ausladung Portée	12 m				24 m				36 m				
	10°		30°		10°		30°		10°		30°		
	0	75	0	75	0	75	0	75	0	75	0	75	
m	t	t	t	t	t	t	t	t	t	t	t	t	
12	80,0	80,0	-	-	-	-	-	-	-	-	-	-	
14	80,0	80,0	-	-	-	-	-	-	-	-	-	-	
16	80,0	80,0	38,0	38,0	48,0	48,0	-	-	-	-	-	-	
18	80,0	80,0	37,0	37,0	44,0	44,0	-	-	31,0	31,0	-	-	
20	74,0	74,0	35,0	35,0	40,0	40,0	-	-	30,0	30,0	-	-	
22	69,0	69,0	34,0	34,0	37,0	37,0	20,0	20,0	28,0	28,0	-	-	
24	64,0	64,0	33,0	33,0	35,0	35,0	19,0	19,0	26,0	26,0	-	-	
26	60,0	60,0	32,0	32,0	33,0	33,0	18,0	18,0	24,0	24,0	-	-	
28	56,0	56,0	31,0	31,0	31,0	31,0	18,0	18,0	23,0	23,0	-	-	
30	53,0	53,0	30,0	30,0	29,0	29,0	17,0	17,0	21,0	21,0	12,0	12,0	
34	48,0	48,0	28,0	28,0	26,0	26,0	16,0	16,0	19,0	19,0	11,0	11,0	
38	44,0	44,0	27,0	27,0	24,0	24,0	15,0	15,0	17,0	17,0	10,0	10,0	
42	40,0	40,0	25,0	25,0	22,0	22,0	14,0	14,0	15,0	15,0	10,0	10,0	
46	36,0	37,0	24,0	24,0	20,0	20,0	13,0	13,0	14,0	14,0	9,0	9,0	
50	32,0	34,0	23,0	23,0	18,0	18,0	13,0	13,0	13,0	13,0	9,0	9,0	
54	28,0	32,0	23,0	23,0	17,0	17,0	12,0	12,0	12,0	12,0	8,0	8,0	
58	24,0	30,0	-	-	16,0	16,0	12,0	12,0	11,0	11,0	8,0	8,0	
62	21,0	29,0	-	-	15,0	15,0	11,0	11,0	10,0	10,0	7,0	7,0	
66	-	-	-	-	14,0	14,0	11,0	11,0	9,0	9,0	7,0	7,0	
70	-	-	-	-	14,0	14,0	-	-	9,0	9,0	7,0	7,0	
74	-	-	-	-	13,0	13,0	-	-	8,0	8,0	6,0	6,0	
78	-	-	-	-	-	-	-	-	8,0	8,0	6,0	6,0	
82	-	-	-	-	-	-	-	-	7,0	7,0	-	-	
86	-	-	-	-	-	-	-	-	7,0	7,0	-	-	
90	-	-	-	-	-	-	-	-	-	-	-	-	

72 m		Main boom · Hauptausleger · Fleche principale							
m	t	t	t	t	t	t	t	t	t
	12	80,0	80,0	-	-	-	-	-	-
14	80,0	80,0	-	-	-	-	-	-	-
16	80,0	80,0	39,0	39,0	50,0	50,0	-	-	-
18	80,0	80,0	37,0	37,0	46,0	46,0	-	-	-
20	80,0	80,0	36,0	36,0	43,0	43,0	-	-	31,0
22	75,0	75,0	35,0	35,0	40,0	40,0	-	-	29,0
24	70,0	70,0	34,0	34,0	37,0	37,0	19,0	19,0	28,0
26	66,0	66,0	33,0	33,0	35,0	35,0	19,0	19,0	26,0
28	62,0	62,0	32,0	32,0	33,0	33,0	18,0	18,0	24,0
30	59,0	59,0	31,0	31,0	31,0	31,0	18,0	18,0	23,0
34	53,0	53,0	29,0	29,0	28,0	28,0	16,0	16,0	20,0
38	46,0	49,0	28,0	28,0	26,0	26,0	16,0	16,0	18,0
42	40,0	45,0	27,0	27,0	24,0	24,0	15,0	15,0	17,0
46	34,0	41,0	26,0	26,0	22,0	22,0	14,0	14,0	15,0
50	29,0	39,0	25,0	25,0	20,0	20,0	13,0	13,0	14,0
54	25,0	36,0	24,0	24,0	19,0	19,0	13,0	13,0	13,0
58	22,0	34,0	23,0	23,0	18,0	18,0	12,0	12,0	12,0
62	19,0	32,0	20,0	23,0	17,0	17,0	12,0	12,0	11,0
66	16,0	31,0	-	-	16,0	16,0	11,0	11,0	10,0
70	14,0	29,0	-	-	15,0	15,0	11,0	11,0	10,0
74	12,0	28,0	-	-	14,0	14,0	11,0	11,0	9,0
78	-	-	-	-	12,0	14,0	-	-	9,0
82	-	-	-	-	10,0	13,0	-	-	8,0
86	-	-	-	-	9,0	13,0	-	-	8,0
90	-	-	-	-	-	-	-	-	7,0
94	-	-	-	-	-	-	-	-	7,0
98	-	-	-	-	-	-	-	-	6,0

# Lifting capacities fixed fly jib with Superlift

## Tragfähigkeiten starrer Hilfsausleger mit Superlift

### Capacités de levage fléchette fixe avec Superlift

180 t + 60 t ZB 

8,40 m 

SL-Radius 15 m

360°

DIN/ISO

84 m		Main boom · Hauptausleger · Flèche principale								Fly jib · Hilfsausleger · Fléchette							
Radius Ausladung Portée	m	12 m				24 m				36 m							
		10°		30°		10°		30°		10°		30°					
		0 t	125 t	0 t	75 t	0 t	75 t	0 t	75 t	0 t	75 t	0 t	75 t				
14	80,0	80,0	-	-	-	-	-	-	-	-	-	-	-				
16	80,0	80,0	-	-	-	-	-	-	-	-	-	-	-				
18	80,0	80,0	38,0	38,0	48,0	48,0	-	-	-	-	-	-	-				
20	80,0	80,0	37,0	37,0	45,0	45,0	-	-	29,0	29,0	-	-	-				
22	79,0	79,0	36,0	36,0	42,0	42,0	-	-	29,0	29,0	-	-	-				
24	76,0	76,0	35,0	35,0	40,0	40,0	20,0	20,0	28,0	28,0	-	-	-				
26	72,0	72,0	34,0	34,0	37,0	37,0	19,0	19,0	27,0	27,0	-	-	-				
28	68,0	68,0	33,0	33,0	35,0	35,0	18,0	18,0	26,0	26,0	-	-	-				
30	64,0	64,0	32,0	32,0	34,0	34,0	18,0	18,0	24,0	24,0	-	-	-				
34	53,0	58,0	30,0	30,0	30,0	30,0	17,0	17,0	22,0	22,0	12,0	12,0	-				
38	44,0	53,0	29,0	29,0	28,0	28,0	16,0	16,0	19,0	19,0	11,0	11,0	-				
42	37,0	49,0	28,0	28,0	26,0	26,0	15,0	15,0	18,0	18,0	10,0	10,0	-				
46	32,0	46,0	27,0	27,0	24,0	24,0	14,0	14,0	16,0	16,0	10,0	10,0	-				
50	27,0	43,0	26,0	26,0	22,0	22,0	14,0	14,0	15,0	15,0	9,0	9,0	-				
54	23,0	40,0	24,0	25,0	21,0	21,0	13,0	13,0	14,0	14,0	9,0	9,0	-				
58	19,0	38,0	20,0	24,0	19,0	19,0	13,0	13,0	13,0	13,0	8,0	8,0	-				
62	16,0	36,0	17,0	24,0	18,0	18,0	12,0	12,0	12,0	12,0	8,0	8,0	-				
66	14,0	34,0	14,0	23,0	15,0	17,0	12,0	12,0	11,0	11,0	7,0	7,0	-				
70	11,0	32,0	12,0	22,0	13,0	16,0	12,0	12,0	11,0	11,0	7,0	7,0	-				
74	9,0	31,0	-	-	11,0	15,0	11,0	11,0	10,0	10,0	7,0	7,0	-				
78	7,0	29,0	-	-	9,0	15,0	10,0	11,0	9,0	9,0	7,0	7,0	-				
82	6,0	28,0	-	-	8,0	14,0	9,0	11,0	9,0	9,0	6,0	6,0	-				
86	4,0	27,0	-	-	6,0	14,0	-	-	7,0	8,0	6,0	6,0	-				
90	-	-	-	-	5,0	13,0	-	-	6,0	8,0	6,0	6,0	-				
94	-	-	-	-	4,0	13,0	-	-	5,0	8,0	6,0	6,0	-				
98	-	-	-	-	-	-	-	-	4,0	7,0	-	-	-				
102	-	-	-	-	-	-	-	-	3,0	7,0	-	-	-				
106	-	-	-	-	-	-	-	-	2,0	7,0	-	-	-				
110	-	-	-	-	-	-	-	-	-	-	-	-	-				

90 m		Main boom · Hauptausleger · Flèche principale							
Radius Ausladung Portée	m	0 t	175 t	0 t	75 t	0 t	75 t	0 t	75 t
		14	80,0	80,0	-	-	-	-	-
16	80,0	80,0	-	-	-	-	-	-	-
18	80,0	80,0	40,0	40,0	50,0	50,0	-	-	-
20	80,0	80,0	39,0	39,0	47,0	47,0	-	-	29,0
22	80,0	80,0	37,0	37,0	45,0	45,0	-	-	29,0
24	80,0	80,0	36,0	36,0	43,0	43,0	-	-	27,0
26	77,0	77,0	35,0	35,0	41,0	41,0	20,0	20,0	26,0
28	72,0	73,0	34,0	34,0	39,0	39,0	19,0	19,0	25,0
30	65,0	69,0	33,0	33,0	37,0	37,0	19,0	19,0	24,0
34	53,0	63,0	32,0	32,0	33,0	33,0	18,0	18,0	23,0
38	44,0	57,0	30,0	30,0	30,0	30,0	17,0	17,0	21,0
42	37,0	53,0	29,0	29,0	28,0	28,0	16,0	16,0	20,0
46	32,0	49,0	28,0	28,0	26,0	26,0	15,0	15,0	18,0
50	27,0	46,0	27,0	27,0	24,0	24,0	14,0	14,0	16,0
54	23,0	43,0	24,0	26,0	22,0	22,0	14,0	14,0	15,0
58	19,0	40,0	20,0	25,0	21,0	21,0	13,0	13,0	14,0
62	16,0	38,0	17,0	24,0	18,0	20,0	13,0	13,0	13,0
66	13,0	36,0	14,0	24,0	15,0	19,0	12,0	12,0	12,0
70	11,0	34,0	12,0	23,0	13,0	18,0	12,0	12,0	11,0
74	9,0	33,0	10,0	23,0	11,0	17,0	12,0	12,0	11,0
78	7,0	31,0	8,0	22,0	9,0	16,0	10,0	11,0	10,0
82	6,0	30,0	-	-	7,0	15,0	9,0	11,0	9,0
86	4,0	29,0	-	-	6,0	15,0	7,0	11,0	7,0
90	3,0	28,0	-	-	4,0	14,0	-	-	6,0
94	-	-	-	-	3,0	13,0	-	-	4,0
98	-	-	-	-	2,0	13,0	-	-	3,0
102	-	-	-	-	-	13,0	-	-	2,0
106	-	-	-	-	-	-	-	-	7,0
110	-	-	-	-	-	-	-	-	7,0
114	-	-	-	-	-	-	-	-	7,0
118	-	-	-	-	-	-	-	-	-

[MAIN MENUE](#)

[Inhalt](#)

[Contents](#)

[Contenu](#)

180 t + 60 t ZB



8,40 m

SL-Radius 15 m

360°

DIN/ISO

102 m Main boom · Hauptausleger · Fleche principale

Radius Ausladung Portée	12 m				Fly jib · Hilfsausleger · Fléchette				36 m			
	10°		30°		10°		30°		10°		30°	
	0	175	0	125	0	125	0	75	0	75	0	75
m	t	t	t	t	t	t	t	t	t	t	t	t
16	80,0	80,0	-	-	-	-	-	-	-	-	-	-
18	80,0	80,0	-	-	45,0	45,0	-	-	-	-	-	-
20	80,0	80,0	39,0	39,0	45,0	45,0	-	-	-	-	-	-
22	80,0	80,0	38,0	38,0	43,0	43,0	-	-	26,0	26,0	-	-
24	80,0	80,0	37,0	37,0	42,0	42,0	-	-	26,0	26,0	-	-
26	79,0	79,0	36,0	36,0	41,0	41,0	20,0	20,0	25,0	25,0	-	-
28	71,0	78,0	35,0	35,0	40,0	40,0	20,0	20,0	24,0	24,0	-	-
30	64,0	74,0	34,0	34,0	39,0	39,0	19,0	19,0	24,0	24,0	-	-
34	52,0	68,0	33,0	33,0	35,0	35,0	18,0	18,0	22,0	22,0	12,0	12,0
38	43,0	62,0	31,0	31,0	32,0	32,0	17,0	17,0	21,0	21,0	12,0	12,0
42	36,0	57,0	30,0	30,0	30,0	30,0	16,0	16,0	20,0	20,0	11,0	11,0
46	30,0	53,0	29,0	29,0	28,0	28,0	16,0	16,0	19,0	19,0	10,0	10,0
50	25,0	50,0	27,0	28,0	26,0	26,0	15,0	15,0	18,0	18,0	10,0	10,0
54	21,0	47,0	23,0	27,0	23,0	24,0	14,0	14,0	16,0	16,0	9,0	9,0
58	18,0	44,0	19,0	26,0	20,0	22,0	14,0	14,0	15,0	15,0	9,0	9,0
62	15,0	41,0	16,0	25,0	17,0	21,0	13,0	13,0	14,0	14,0	8,0	8,0
66	12,0	39,0	13,0	25,0	14,0	20,0	13,0	13,0	13,0	13,0	8,0	8,0
70	10,0	37,0	11,0	24,0	11,0	19,0	12,0	12,0	12,0	12,0	8,0	8,0
74	8,0	36,0	9,0	23,0	9,0	18,0	11,0	12,0	11,0	12,0	7,0	7,0
78	6,0	34,0	7,0	23,0	8,0	17,0	9,0	12,0	9,0	11,0	7,0	7,0
82	4,0	33,0	5,0	23,0	6,0	16,0	7,0	11,0	7,0	10,0	7,0	7,0
86	3,0	31,0	3,0	22,0	4,0	16,0	6,0	11,0	6,0	10,0	7,0	7,0
90	2,0	30,0	-	-	3,0	15,0	4,0	11,0	4,0	9,0	6,0	6,0
94	-	29,0	-	-	2,0	14,0	3,0	11,0	3,0	9,0	5,0	6,0
98	-	27,0	-	-	-	14,0	2,0	11,0	2,0	9,0	3,0	6,0
102	-	25,0	-	-	-	13,0	-	-	-	8,0	2,0	6,0
106	-	-	-	-	-	13,0	-	-	-	8,0	-	6,0
110	-	-	-	-	-	13,0	-	-	-	8,0	-	-
114	-	-	-	-	-	-	-	-	-	7,0	-	-
118	-	-	-	-	-	-	-	-	-	7,0	-	-
122	-	-	-	-	-	-	-	-	-	6,0	-	-

Remarks · Bemerkungen · Remarques

Superlift mast · Superlift-Mast · Mât Superlift 30 m

MAIN MENU

Inhalt

Contents

Contenu



# Lifting capacities fixed fly jib with Superlift

## Tragfähigkeiten starrer Hilfsausleger mit Superlift

### Capacités de levage fléchette fixe avec Superlift

180 t + 60 t ZB   8,40 m SL-Radius 15 m 360° DIN/ISO

114 m		Main boom · Hauptausleger · Flèche principale				Fly jib · Hilfsausleger · Fléchette							
Radius Ausladung Portée		12 m				24 m				36 m			
		10°		30°		10°		30°		10°		30°	
		0	225	0	125	0	175	0	75	0	125	0	75
m	t	t	t	t	t	t	t	t	t	t	t	t	
16	74,0	74,0	-	-	-	-	-	-	-	-	-	-	
18	74,0	74,0	-	-	-	-	-	-	-	-	-	-	
20	73,0	73,0	40,0	40,0	44,0	44,0	-	-	-	-	-	-	
22	72,0	72,0	39,0	39,0	42,0	42,0	-	-	26,0	26,0	-	-	
24	72,0	72,0	38,0	38,0	41,0	41,0	-	-	26,0	26,0	-	-	
26	71,0	71,0	37,0	37,0	40,0	40,0	-	-	25,0	25,0	-	-	
28	70,0	70,0	36,0	36,0	39,0	39,0	20,0	20,0	24,0	24,0	-	-	
30	62,0	69,0	35,0	35,0	38,0	38,0	19,0	19,0	24,0	24,0	-	-	
34	51,0	68,0	34,0	34,0	37,0	37,0	18,0	18,0	22,0	22,0	12,0	12,0	
38	42,0	66,0	32,0	32,0	34,0	34,0	17,0	17,0	21,0	21,0	12,0	12,0	
42	35,0	61,0	31,0	31,0	32,0	32,0	17,0	17,0	20,0	20,0	11,0	11,0	
46	29,0	57,0	30,0	30,0	29,0	29,0	16,0	16,0	19,0	19,0	10,0	10,0	
50	24,0	53,0	25,0	29,0	26,0	27,0	15,0	15,0	18,0	18,0	10,0	10,0	
54	19,0	50,0	21,0	28,0	21,0	26,0	15,0	15,0	17,0	17,0	9,0	9,0	
58	16,0	47,0	17,0	27,0	18,0	24,0	14,0	14,0	16,0	16,0	9,0	9,0	
SSL / LSL + LF	62	13,0	45,0	14,0	26,0	15,0	23,0	14,0	14,0	15,0	15,0	9,0	9,0
	66	10,0	42,0	11,0	25,0	12,0	21,0	13,0	13,0	13,0	14,0	8,0	8,0
	70	8,0	40,0	9,0	25,0	10,0	20,0	12,0	13,0	11,0	13,0	8,0	8,0
	74	6,0	38,0	7,0	24,0	8,0	19,0	10,0	12,0	9,0	12,0	8,0	8,0
	78	4,0	37,0	5,0	24,0	6,0	18,0	7,0	12,0	7,0	12,0	7,0	7,0
	82	2,0	35,0	3,0	23,0	4,0	17,0	6,0	12,0	5,0	11,0	7,0	7,0
	86	-	34,0	2,0	23,0	2,0	17,0	4,0	11,0	4,0	11,0	6,0	7,0
	90	-	33,0	-	22,0	-	16,0	2,0	11,0	2,0	10,0	5,0	7,0
	84	-	31,0	-	20,0	-	15,0	-	11,0	-	10,0	3,0	6,0
	98	-	30,0	-	-	-	15,0	-	11,0	-	9,0	2,0	6,0
	102	-	26,0	-	-	-	14,0	-	10,0	-	9,0	-	6,0
	106	-	21,0	-	-	-	14,0	-	9,0	-	8,0	-	6,0
	110	-	15,0	-	-	-	13,0	-	-	-	8,0	-	6,0
	114	-	-	-	-	-	13,0	-	-	-	8,0	-	6,0
	118	-	-	-	-	-	13,0	-	-	-	7,0	-	6,0
	122	-	-	-	-	-	12,0	-	-	-	7,0	-	-
	126	-	-	-	-	-	-	-	-	-	7,0	-	-
	130	-	-	-	-	-	-	-	-	-	7,0	-	-
	134	-	-	-	-	-	-	-	-	-	7,0	-	-
	138	-	-	-	-	-	-	-	-	-	-	-	-

Remarks · Bemerkungen · Remarques

Superlift mast · Superlift-Mast · Mât Superlift 30 m

MAIN MENU

Inhalt

Contents

Contenu

180 t + 60 t ZB



8,40 m

SL-Radius 15 m

360°

DIN/ISO

126 m Main boom · Hauptausleger · Flèche principale

Radius Ausladung Portée	12 m				Fly jib · Hilfsausleger · Fléchette				36 m				
	10°		30°		10°		30°		10°		30°		
	0	125	0	125	0	125	0	75	0	125	0	75	
m	t	t	t	t	t	t	t	t	t	t	t	t	
18	60,0	60,0	-	-	-	-	-	-	-	-	-	-	
20	58,0	58,0	-	-	40,0	40,0	-	-	-	-	-	-	
22	57,0	57,0	39,0	39,0	40,0	40,0	-	-	-	-	-	-	
24	55,0	55,0	38,0	38,0	39,0	39,0	-	-	24,0	24,0	-	-	
26	54,0	54,0	37,0	37,0	38,0	38,0	-	-	24,0	24,0	-	-	
28	53,0	53,0	36,0	36,0	37,0	37,0	20,0	20,0	23,0	23,0	-	-	
30	51,0	51,0	36,0	36,0	36,0	36,0	19,0	19,0	23,0	23,0	-	-	
34	49,0	49,0	34,0	34,0	34,0	34,0	18,0	18,0	22,0	22,0	-	-	
38	41,0	47,0	33,0	33,0	33,0	33,0	18,0	18,0	21,0	21,0	12,0	12,0	
42	34,0	45,0	32,0	32,0	31,0	31,0	17,0	17,0	20,0	20,0	11,0	11,0	
46	28,0	43,0	30,0	31,0	30,0	30,0	16,0	16,0	19,0	19,0	11,0	11,0	
50	23,0	40,0	25,0	29,0	25,0	29,0	16,0	16,0	18,0	18,0	10,0	10,0	
54	18,0	38,0	20,0	29,0	20,0	27,0	15,0	15,0	17,0	17,0	10,0	10,0	
SSL / LSL + LF	58	15,0	36,0	16,0	28,0	17,0	25,0	14,0	14,0	17,0	17,0	9,0	9,0
	62	12,0	34,0	13,0	27,0	14,0	24,0	14,0	14,0	15,0	16,0	9,0	9,0
	66	9,0	31,0	10,0	26,0	11,0	23,0	13,0	13,0	12,0	15,0	8,0	8,0
	70	7,0	28,0	8,0	26,0	8,0	22,0	11,0	13,0	10,0	14,0	8,0	8,0
	74	5,0	25,0	6,0	25,0	6,0	20,0	9,0	13,0	8,0	13,0	8,0	8,0
	78	3,0	21,0	4,0	24,0	4,0	19,0	6,0	12,0	6,0	12,0	7,0	7,0
	82	-	17,0	2,0	22,0	3,0	19,0	5,0	12,0	4,0	12,0	7,0	7,0
	86	-	13,0	-	16,0	-	18,0	3,0	12,0	2,0	11,0	5,0	7,0
	90	-	7,0	-	10,0	-	17,0	-	11,0	-	11,0	4,0	7,0
	84	-	-	-	2,0	-	15,0	-	11,0	-	10,0	2,0	7,0
	98	-	-	-	-	-	12,0	-	10,0	-	10,0	-	6,0
	102	-	-	-	-	-	9,0	-	8,0	-	9,0	-	6,0
	106	-	-	-	-	-	6,0	-	5,0	-	9,0	-	6,0
	110	-	-	-	-	-	2,0	-	-	-	9,0	-	6,0
	114	-	-	-	-	-	-	-	-	-	8,0	-	6,0
	118	-	-	-	-	-	-	-	-	-	6,0	-	5,0
	122	-	-	-	-	-	-	-	-	-	4,0	-	4,0
	126	-	-	-	-	-	-	-	-	-	2,0	-	2,0

138 m Main boom · Hauptausleger · Flèche principale

	0	75	0	75	0	75	0	75	0	75	0	75	
	t	t	t	t	t	t	t	t	t	t	t	t	
18	52,0	52,0	-	-	-	-	-	-	-	-	-	-	
20	51,0	51,0	-	-	-	-	-	-	-	-	-	-	
22	49,0	49,0	39,0	39,0	34,0	34,0	-	-	-	-	-	-	
24	47,0	47,0	38,0	38,0	34,0	34,0	-	-	22,0	22,0	-	-	
26	45,0	45,0	38,0	38,0	33,0	33,0	-	-	22,0	22,0	-	-	
28	43,0	43,0	37,0	37,0	33,0	33,0	-	-	21,0	21,0	-	-	
30	41,0	41,0	36,0	36,0	32,0	32,0	19,0	19,0	21,0	21,0	-	-	
34	38,0	38,0	35,0	35,0	30,0	30,0	19,0	19,0	20,0	20,0	-	-	
38	34,0	34,0	33,0	33,0	28,0	28,0	18,0	18,0	19,0	19,0	12,0	12,0	
SSL / LSL + LF	42	32,0	32,0	32,0	26,0	26,0	17,0	17,0	18,0	18,0	11,0	11,0	
	46	26,0	29,0	28,0	31,0	24,0	24,0	16,0	16,0	18,0	18,0	11,0	11,0
	50	21,0	26,0	23,0	30,0	23,0	23,0	16,0	16,0	18,0	18,0	10,0	10,0
	54	17,0	23,0	19,0	29,0	19,0	21,0	15,0	15,0	18,0	18,0	10,0	10,0
	58	13,0	20,0	15,0	26,0	15,0	19,0	15,0	15,0	16,0	17,0	9,0	9,0
	62	10,0	16,0	12,0	23,0	12,0	17,0	14,0	14,0	13,0	17,0	9,0	9,0
	66	7,0	13,0	9,0	19,0	9,0	15,0	12,0	13,0	10,0	16,0	8,0	8,0
	70	5,0	10,0	6,0	15,0	7,0	13,0	9,0	11,0	8,0	15,0	8,0	8,0
	74	3,0	6,0	4,0	10,0	5,0	11,0	7,0	8,0	6,0	13,0	7,0	7,0
	78	-	3,0	2,0	5,0	3,0	8,0	5,0	6,0	4,0	11,0	6,0	6,0
	82	-	-	-	-	-	5,0	3,0	4,0	2,0	9,0	4,0	4,0
	86	-	-	-	-	-	-	-	-	-	7,0	2,0	2,0
	90	-	-	-	-	-	-	-	-	-	4,0	-	-
	94	-	-	-	-	-	-	-	-	-	-	-	-

MAIN MENUE

Inhalt

Contents

Contenu

# Working ranges fixed fly jib with SL, 30°

## Arbeitsbereiche starrer Hilfsausleger mit SL, 30°

### Portées fléchette fixe avec SL, 30°

SSL + LF, SSL/LSL + LF

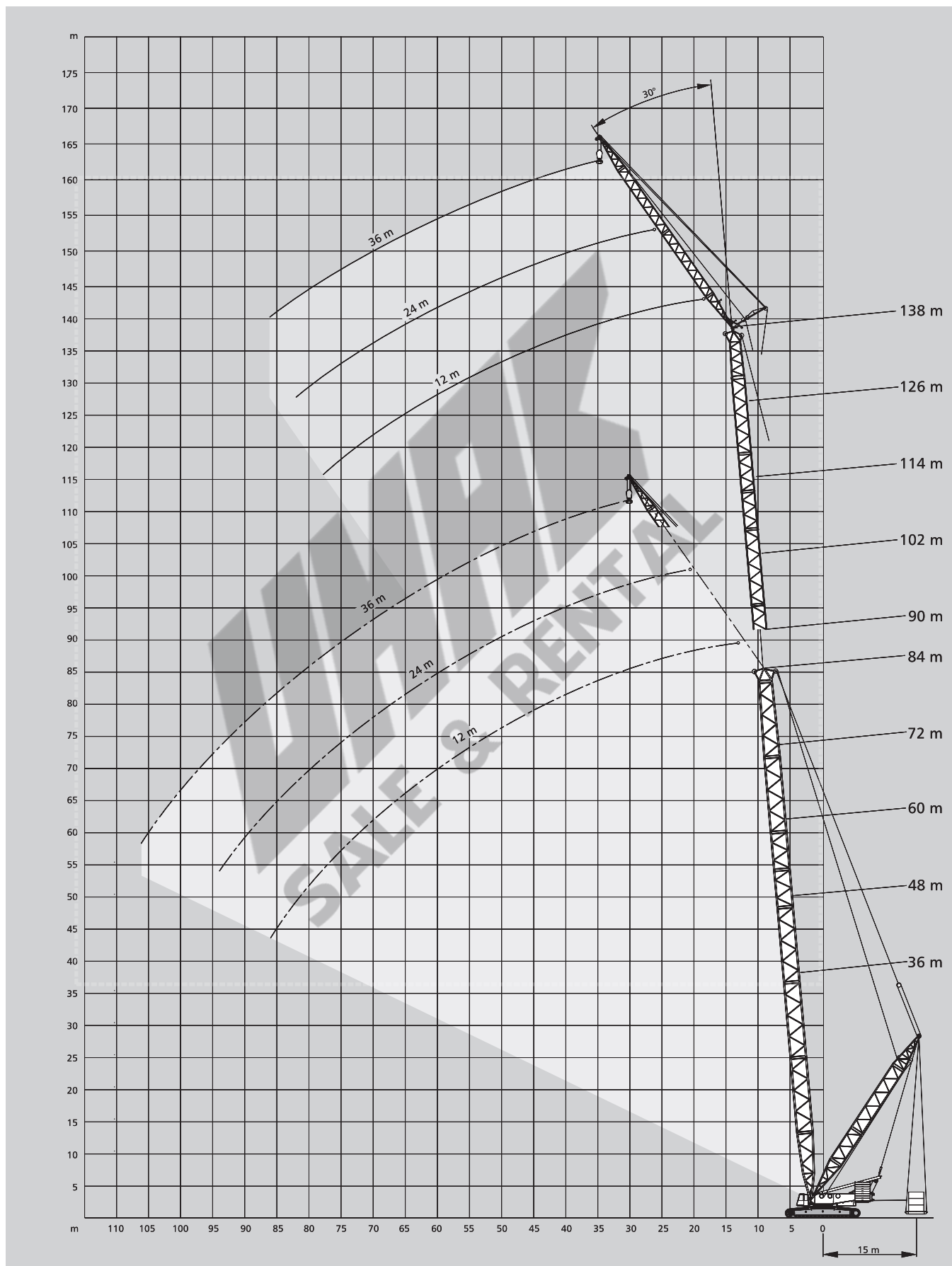

[MAIN MENUE](#)

[Inhalt](#)

[Contents](#)

[Contenu](#)

# Working ranges luffing fly jib, main boom 85° Arbeitsbereiche wippbarer Hilfsausleger, Hauptausleger 85° Portées fléchette à volée variable, flèche 85°

SW

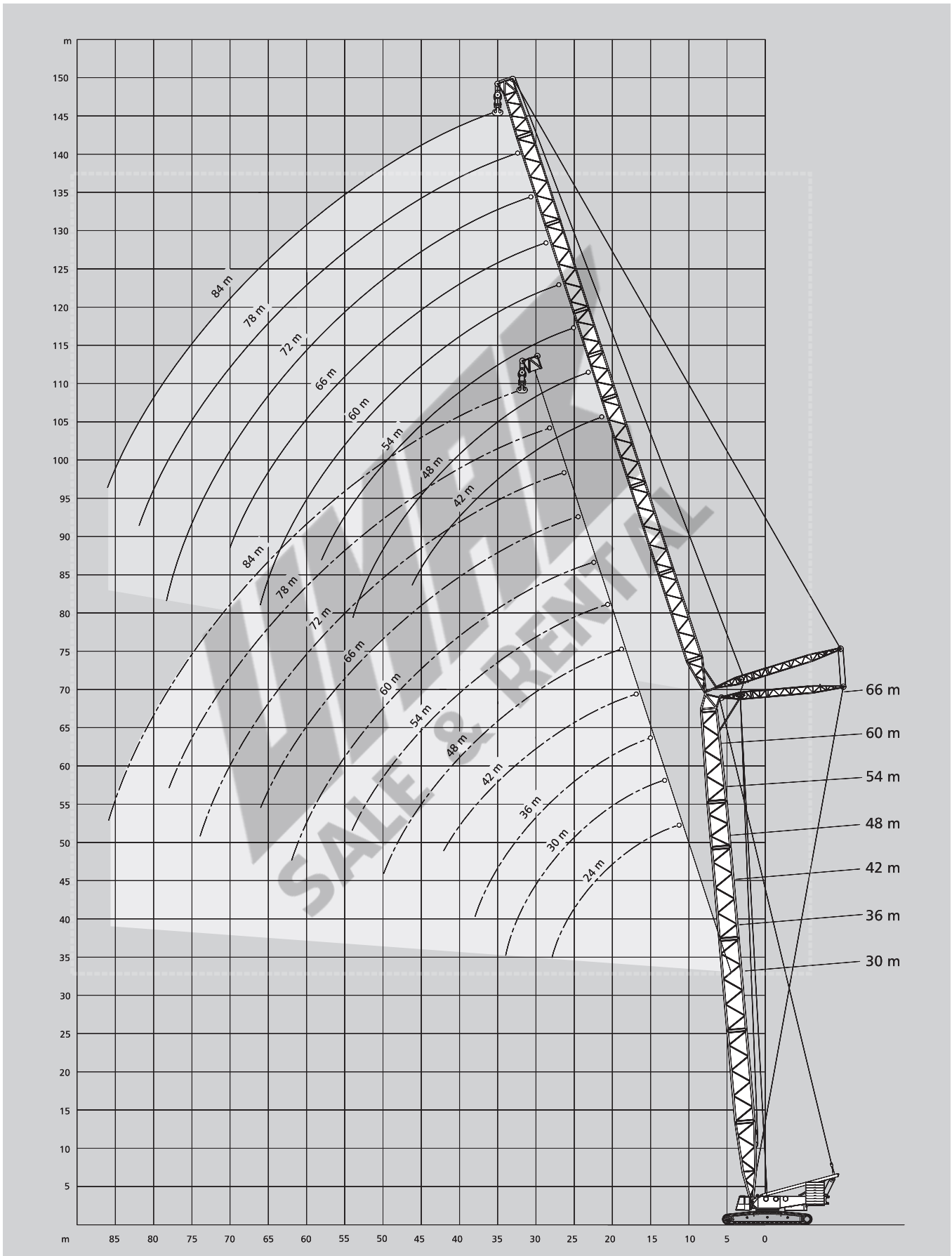

[MAIN MENUE](#)

[Inhalt](#)

[Contents](#)

[Contenu](#)

# Lifting capacities luffing fly jib, main boom 85° Tragfähigkeiten wippbarer Hilfsausleger, Hauptausleger 85° Capacités de levage fléchette à volée variable, flèche 85°

180 t + 60 t ZB



8,40 m

360°

DIN/ISO

30 m		Main boom · Hauptausleger · Flèche principale											
Radius Ausladung Portée	m	Fly jib · Hilfsausleger · Fléchette											
		24,0	30,0	36,0	42,0	48,0	54,0	60,0	66,0	72,0	78,0	84,0	
m	t	t	t	t	t	t	t	t	t	t	t	t	
14	207,0	-	-	-	-	-	-	-	-	-	-	-	
16	171,0	170,0	-	-	-	-	-	-	-	-	-	-	
18	145,0	144,0	143,0	-	-	-	-	-	-	-	-	-	
20	125,0	124,0	124,0	123,0	-	-	-	-	-	-	-	-	
22	110,0	109,0	109,0	108,0	107,0	-	-	-	-	-	-	-	
24	98,0	97,0	97,0	96,0	95,0	94,0	-	-	-	-	-	-	
26	88,0	87,0	87,0	86,0	85,0	84,0	83,0	-	-	-	-	-	
28	80,0	79,0	79,0	78,0	77,0	76,0	75,0	74,0	-	-	-	-	
30	-	72,0	72,0	71,0	70,0	69,0	68,0	68,0	67,0	-	-	-	
SW	34	-	61,0	61,0	60,0	59,0	58,0	57,0	57,0	56,0	55,0	54,0	
	38	-	-	52,0	51,0	51,0	50,0	49,0	48,0	47,0	47,0	46,0	
	42	-	-	-	45,0	44,0	43,0	42,0	42,0	41,0	40,0	39,0	
	46	-	-	-	-	39,0	38,0	37,0	36,0	35,0	35,0	34,0	
	50	-	-	-	-	34,0	33,0	33,0	32,0	31,0	31,0	30,0	
	54	-	-	-	-	-	30,0	29,0	28,0	27,0	27,0	26,0	
	58	-	-	-	-	-	-	26,0	25,0	24,0	24,0	23,0	
	62	-	-	-	-	-	-	23,0	22,0	21,0	21,0	20,0	
	66	-	-	-	-	-	-	-	20,0	19,0	19,0	18,0	
	70	-	-	-	-	-	-	-	-	17,0	16,0	15,0	
	74	-	-	-	-	-	-	-	-	15,0	15,0	13,0	
	78	-	-	-	-	-	-	-	-	-	13,0	12,0	
	82	-	-	-	-	-	-	-	-	-	-	10,0	
	86	-	-	-	-	-	-	-	-	-	-	9,0	

36 m		Main boom · Hauptausleger · Flèche principale											
m	t	t											
		t	t	t	t	t	t	t	t	t	t	t	
16	169,0	-	-	-	-	-	-	-	-	-	-	-	
18	144,0	143,0	142,0	-	-	-	-	-	-	-	-	-	
20	124,0	123,0	123,0	122,0	-	-	-	-	-	-	-	-	
22	109,0	108,0	108,0	107,0	106,0	-	-	-	-	-	-	-	
24	97,0	96,0	96,0	95,0	94,0	93,0	-	-	-	-	-	-	
26	87,0	87,0	86,0	85,0	84,0	83,0	82,0	-	-	-	-	-	
28	79,0	79,0	78,0	77,0	76,0	75,0	74,0	74,0	-	-	-	-	
30	-	72,0	71,0	70,0	69,0	68,0	68,0	67,0	66,0	-	-	-	
SW	34	-	61,0	60,0	59,0	58,0	57,0	57,0	56,0	55,0	55,0	54,0	
	38	-	-	52,0	51,0	50,0	49,0	48,0	48,0	47,0	46,0	45,0	
	42	-	-	-	44,0	44,0	42,0	42,0	41,0	40,0	40,0	39,0	
	46	-	-	-	39,0	38,0	37,0	36,0	36,0	35,0	34,0	34,0	
	50	-	-	-	-	34,0	33,0	32,0	31,0	30,0	30,0	29,0	
	54	-	-	-	-	-	29,0	28,0	28,0	27,0	26,0	26,0	
	58	-	-	-	-	-	26,0	25,0	25,0	24,0	23,0	22,0	
	62	-	-	-	-	-	-	23,0	22,0	21,0	21,0	20,0	
	66	-	-	-	-	-	-	-	20,0	19,0	18,0	17,0	
	70	-	-	-	-	-	-	-	-	16,0	16,0	15,0	
	74	-	-	-	-	-	-	-	-	15,0	14,0	13,0	
	78	-	-	-	-	-	-	-	-	-	13,0	11,0	
	82	-	-	-	-	-	-	-	-	-	-	10,0	
	86	-	-	-	-	-	-	-	-	-	-	9,0	
	90	-	-	-	-	-	-	-	-	-	-	-	

MAIN MENU

Inhalt

Contents

Contenu

180 t + 60 t ZB



8,40 m

360°

DIN/ISO

## 42 m Main boom · Hauptausleger · Flèche principale

Radius Ausladung Portée	m	Fly jib · Hilfsausleger · Fléchette										
		24,0	30,0	36,0	42,0	48,0	54,0	60,0	66,0	72,0	78,0	84,0
m	t	t	t	t	t	t	t	t	t	t	t	t
16	168,0	-	-	-	-	-	-	-	-	-	-	-
18	142,0	142,0	-	-	-	-	-	-	-	-	-	-
20	123,0	122,0	122,0	-	-	-	-	-	-	-	-	-
22	108,0	107,0	107,0	106,0	-	-	-	-	-	-	-	-
24	96,0	96,0	95,0	94,0	93,0	92,0	-	-	-	-	-	-
26	86,0	86,0	85,0	84,0	83,0	82,0	82,0	-	-	-	-	-
28	78,0	78,0	77,0	76,0	75,0	74,0	74,0	73,0	-	-	-	-
30	-	71,0	70,0	69,0	69,0	67,0	67,0	66,0	65,0	-	-	-
34	-	60,0	59,0	58,0	58,0	57,0	56,0	55,0	54,0	54,0	53,0	-
SW	38	-	-	51,0	50,0	49,0	48,0	48,0	47,0	46,0	46,0	45,0
42	-	-	-	44,0	44,0	43,0	42,0	41,0	40,0	39,0	39,0	38,0
46	-	-	-	38,0	38,0	37,0	36,0	35,0	34,0	34,0	34,0	33,0
50	-	-	-	-	33,0	32,0	32,0	31,0	30,0	30,0	30,0	29,0
54	-	-	-	-	-	29,0	28,0	27,0	26,0	26,0	26,0	25,0
58	-	-	-	-	-	26,0	25,0	24,0	23,0	23,0	23,0	22,0
62	-	-	-	-	-	-	22,0	22,0	20,0	20,0	20,0	19,0
66	-	-	-	-	-	-	-	19,0	18,0	18,0	18,0	17,0
70	-	-	-	-	-	-	-	-	17,0	16,0	16,0	14,0
74	-	-	-	-	-	-	-	-	-	14,0	14,0	13,0
78	-	-	-	-	-	-	-	-	-	-	12,0	11,0
82	-	-	-	-	-	-	-	-	-	-	-	10,0
86	-	-	-	-	-	-	-	-	-	-	-	8,0
90	-	-	-	-	-	-	-	-	-	-	-	-

## 48 m Main boom · Hauptausleger · Flèche principale

m	t	t	t	t	t	t	t	t	t	t	t	t
16	167,0	-	-	-	-	-	-	-	-	-	-	-
18	141,0	140,0	-	-	-	-	-	-	-	-	-	-
20	122,0	121,0	121,0	-	-	-	-	-	-	-	-	-
22	107,0	106,0	106,0	105,0	-	-	-	-	-	-	-	-
24	95,0	95,0	94,0	93,0	92,0	-	-	-	-	-	-	-
26	86,0	85,0	84,0	83,0	82,0	81,0	-	-	-	-	-	-
28	77,0	77,0	76,0	75,0	74,0	73,0	73,0	-	-	-	-	-
30	71,0	70,0	70,0	68,0	68,0	67,0	66,0	65,0	-	-	-	-
34	-	59,0	59,0	58,0	57,0	56,0	55,0	54,0	53,0	53,0	53,0	52,0
SW	38	-	-	51,0	49,0	49,0	48,0	47,0	46,0	45,0	45,0	44,0
42	-	-	-	43,0	43,0	42,0	41,0	41,0	40,0	39,0	39,0	38,0
46	-	-	-	38,0	37,0	36,0	35,0	35,0	34,0	34,0	33,0	32,0
50	-	-	-	-	33,0	32,0	31,0	30,0	29,0	29,0	29,0	28,0
54	-	-	-	-	-	28,0	28,0	27,0	26,0	26,0	26,0	24,0
58	-	-	-	-	-	25,0	25,0	24,0	23,0	23,0	23,0	21,0
62	-	-	-	-	-	-	22,0	21,0	20,0	20,0	20,0	18,0
66	-	-	-	-	-	-	-	19,0	18,0	18,0	17,0	16,0
70	-	-	-	-	-	-	-	-	17,0	15,0	15,0	14,0
74	-	-	-	-	-	-	-	-	-	14,0	13,0	12,0
78	-	-	-	-	-	-	-	-	-	-	12,0	11,0
82	-	-	-	-	-	-	-	-	-	-	10,0	9,0
86	-	-	-	-	-	-	-	-	-	-	-	8,0
90	-	-	-	-	-	-	-	-	-	-	-	-

[MAIN MENU](#)[Inhalt](#)[Contents](#)[Contenu](#)

# Lifting capacities luffing fly jib, main boom 85° Tragfähigkeiten wippbarer Hilfsausleger, Hauptausleger 85° Capacités de levage fléchette à volée variable, flèche 85°

180 t + 60 t ZB  8,40 m 360° DIN/ISO

54 m		Main boom · Hauptausleger · Flèche principale										
Radius Ausladung	Portée	m	Fly jib · Hilfsausleger · Fléchette									
			30,0	36,0	42,0	48,0	54,0	60,0	66,0	72,0	78,0	84,0
	m		t	t	t	t	t	t	t	t	t	t
	18		139,0	-	-	-	-	-	-	-	-	-
	20		120,0	119,0	-	-	-	-	-	-	-	-
	22		105,0	105,0	103,0	-	-	-	-	-	-	-
	24		94,0	93,0	92,0	91,0	-	-	-	-	-	-
	26		84,0	83,0	82,0	82,0	80,0	-	-	-	-	-
	28		76,0	75,0	74,0	74,0	72,0	72,0	-	-	-	-
	30		69,0	69,0	68,0	67,0	66,0	65,0	64,0	-	-	-
SW	34		59,0	58,0	57,0	56,0	55,0	54,0	54,0	53,0	52,0	-
	38		-	50,0	49,0	48,0	47,0	46,0	46,0	45,0	44,0	43,0
	42		-	44,0	42,0	42,0	41,0	40,0	39,0	38,0	38,0	37,0
	46		-	-	37,0	37,0	35,0	35,0	34,0	33,0	33,0	32,0
	50		-	-	-	32,0	31,0	31,0	30,0	29,0	29,0	28,0
	54		-	-	-	-	28,0	27,0	26,0	25,0	25,0	24,0
	58		-	-	-	-	25,0	24,0	23,0	22,0	22,0	21,0
	62		-	-	-	-	-	21,0	21,0	19,0	19,0	18,0
	66		-	-	-	-	-	-	18,0	17,0	17,0	16,0
	70		-	-	-	-	-	-	16,0	15,0	15,0	13,0
	74		-	-	-	-	-	-	-	13,0	13,0	12,0
	78		-	-	-	-	-	-	-	-	11,0	10,0
	82		-	-	-	-	-	-	-	-	10,0	9,0
	86		-	-	-	-	-	-	-	-	-	7,0

60 m		Main boom · Hauptausleger · Flèche principale										
Radius Ausladung	Portée	m	Fly jib · Hilfsausleger · Fléchette									
			30,0	36,0	42,0	48,0	54,0	60,0	66,0	72,0	78,0	84,0
	m		t	t	t	t	t	t	t	t	t	t
	20		118,0	-	-	-	-	-	-	-	-	-
	22		103,0	102,0	-	-	-	-	-	-	-	-
	24		92,0	91,0	90,0	-	-	-	-	-	-	-
	26		82,0	81,0	80,0	79,0	-	-	-	-	-	-
	28		75,0	73,0	73,0	71,0	71,0	-	-	-	-	-
	30		68,0	67,0	66,0	65,0	64,0	63,0	-	-	-	-
	34		57,0	56,0	55,0	54,0	54,0	53,0	52,0	50,0	-	-
	38		49,0	48,0	47,0	46,0	46,0	45,0	44,0	43,0	43,0	43,0
SW	42		43,0	42,0	41,0	40,0	39,0	39,0	37,0	37,0	36,0	-
	46		-	37,0	36,0	35,0	34,0	33,0	32,0	32,0	31,0	31,0
	50		-	-	32,0	31,0	30,0	29,0	28,0	28,0	27,0	27,0
	54		-	-	28,0	27,0	26,0	26,0	25,0	24,0	24,0	23,0
	58		-	-	-	24,0	24,0	23,0	21,0	21,0	21,0	20,0
	62		-	-	-	-	21,0	20,0	19,0	18,0	18,0	17,0
	66		-	-	-	-	-	18,0	16,0	16,0	16,0	15,0
	70		-	-	-	-	-	16,0	14,0	14,0	14,0	13,0
	74		-	-	-	-	-	-	13,0	13,0	12,0	11,0
	78		-	-	-	-	-	-	-	11,0	11,0	10,0
	82		-	-	-	-	-	-	-	-	9,0	8,0
	86		-	-	-	-	-	-	-	-	-	7,0

66 m		Main boom · Hauptausleger · Flèche principale										
Radius Ausladung	Portée	m	Fly jib · Hilfsausleger · Fléchette									
			30,0	36,0	42,0	48,0	54,0	60,0	66,0	72,0	78,0	84,0
	m		t	t	t	t	t	t	t	t	t	t
	24		-	-	89,0	-	-	-	-	-	-	-
	26		-	-	80,0	79,0	-	-	-	-	-	-
	28		-	-	72,0	72,0	70,0	66,0	-	-	-	-
	30		-	-	66,0	65,0	64,0	63,0	58,0	-	-	-
	34		-	-	55,0	55,0	53,0	53,0	52,0	51,0	44,0	-
	38		-	-	47,0	47,0	45,0	45,0	44,0	43,0	43,0	39,0
	42		-	-	41,0	40,0	39,0	39,0	38,0	37,0	36,0	36,0
	46		-	-	36,0	35,0	34,0	34,0	33,0	32,0	31,0	30,0
SW	50		-	-	-	31,0	30,0	29,0	29,0	28,0	27,0	26,0
	54		-	-	-	28,0	27,0	26,0	25,0	24,0	24,0	22,0
	58		-	-	-	-	24,0	23,0	22,0	21,0	20,0	19,0
	62		-	-	-	-	-	20,0	19,0	18,0	18,0	17,0
	66		-	-	-	-	-	18,0	17,0	16,0	16,0	14,0
	70		-	-	-	-	-	-	15,0	14,0	13,0	12,0
	74		-	-	-	-	-	-	-	12,0	12,0	11,0
	78		-	-	-	-	-	-	-	11,0	10,0	9,0
	82		-	-	-	-	-	-	-	-	9,0	8,0
	86		-	-	-	-	-	-	-	-	-	7,0

# Working ranges luffing fly jib with SL, main boom 85° Arbeitsbereiche wippbarer Hilfsausleger mit SL, Hauptausleger 85° Portées fléchette à volée variable avec SL, flèche 85°

SWSL

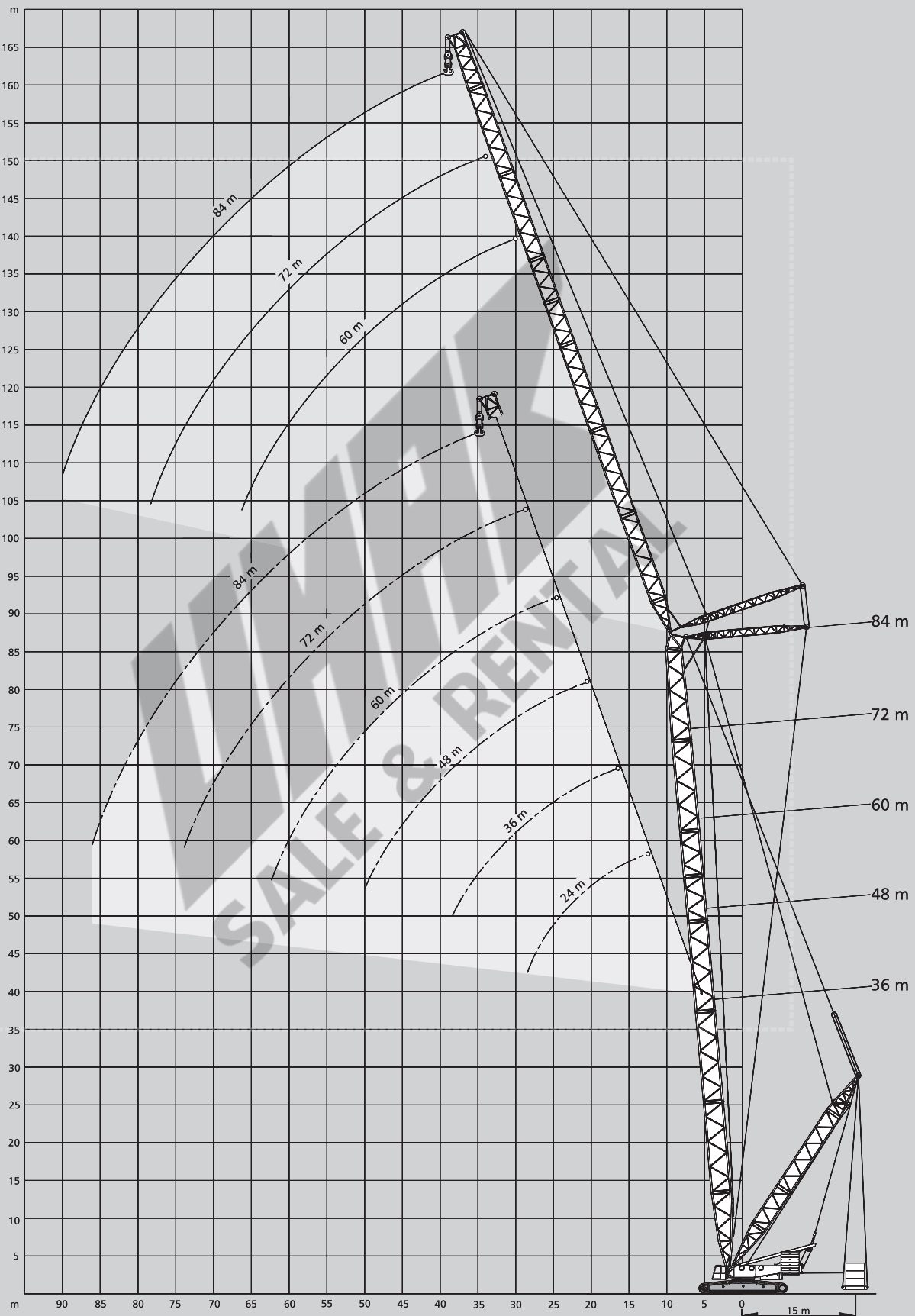

[MAIN MENUE](#)

[Inhalt](#)



[Contents](#)



[Contenu](#)







# Lifting capacities luffing fly jib with SL, main boom 85° Tragfähigkeiten wippbarer Hilfsausleger mit SL, Hauptausleger 85° Capacités de levage fléchette à volée variable avec SL, flèche 85°

160 t   8,40 m SL-Radius 15 m 360° DIN/ISO

36 m Main boom · Hauptausleger · Flèche principale										
Fly jib Hilfsausleger Fléchette	Radius Ausladung Portée									
		0	50	100	150	200	250	225		
	m	t	t	t	t	t	t	t	t	
	16	153	213	272	300	300	-	300		
	18	130	181	231	282	300	-	300		
	20	112	156	201	245	289	300	300		
	22	98	138	177	216	256	275	273		
	24	87	123	158	194	229	247	247		
<b>SWSL</b>	<b>24 m</b>	26	79	111	143	175	207	214	214	
		28	71	100	130	159	182	-	182	

Fly jib · Hilfsausleger · Fléchette										
Fly jib Hilfsausleger Fléchette	Radius Ausladung Portée									
		0	50	100	150	200	225			
	m	t	t	t	t	t	t	t	t	
	30	58	86	94	-	-	-	96		
	34	49	72	94	96	-	-	96		
	38	41	62	82	94	-	-	94		
	42	35	54	72	91	91	-	91		
	46	30	47	64	80	87	-	87		
<b>SWSL</b>	<b>72 m</b>	50	26	42	57	72	83	83		
		54	23	37	51	65	79	79		
		58	20	33	46	59	72	73		
		62	17	30	42	54	64	64		
		66	15	27	38	50	57	57		
		70	13	25	35	46	50	50		
		74	12	22	32	43	43	43		

Fly jib · Hilfsausleger · Fléchette										
Fly jib Hilfsausleger Fléchette	Radius Ausladung Portée									
		0	50	100	150	200	250	225		
	m	t	t	t	t	t	t	t	t	
	18	128	179	230	257	257	-	257		
	20	111	155	199	244	257	-	257		
	22	97	137	176	215	253	253	253		
	24	86	122	157	192	228	239	239		
<b>SWSL</b>	<b>36 m</b>	26	77	110	142	174	206	226	226	
		28	70	99	129	158	188	209	209	
		30	64	91	118	145	172	188	188	
		34	54	77	101	124	148	153	153	
		38	46	67	88	108	124	-	124	

Fly jib · Hilfsausleger · Fléchette										
Fly jib Hilfsausleger Fléchette	Radius Ausladung Portée									
		0	50	100	150	200	225			
	m	t	t	t	t	t	t	t	t	
	22	95	135	174	187	-	-	187		
	24	84	120	155	187	187	-	187		
<b>SWSL</b>	<b>48 m</b>	26	76	108	140	172	187	-	187	
		28	68	98	127	156	180	-	180	
		30	62	89	116	143	171	172	172	
		34	52	76	99	123	146	156	156	
		38	44	65	86	107	127	137	137	
		42	38	57	76	94	113	117	117	
		46	34	50	67	84	100	-	100	
		50	30	45	60	76	84	-	84	

Remarks · Bemerkungen · Remarques

Superlift mast · Superlift-Mast · Mât Superlift 30 m

160 t



8,40 m

SL-Radius 15 m

360°

DIN/ISO

48 m Main boom · Hauptausleger · Flèche principale

Fly jib Hilfsausleger Fléchette	Radius Ausladung Portée	SL							SL
		0	50	100	150	200	250	275	
m	t	t	t	t	t	t	t	t	
16	151	210	269	296	296	-	296		
18	127	178	229	280	296	-	296		
20	110	154	199	243	279	279			
<b>SWSL 24 m</b>	22	97	136	175	215	254	263	263	
	24	86	121	156	192	227	248	248	
	26	77	109	141	173	205	229	229	
	28	70	99	128	158	187	196	197	
	30	63	90	118	145	163	-	165	

Fly jib Hilfsausleger Fléchette	Radius Ausladung Portée	SL							SL
		0	50	100	150	200	225		
m	t	t	t	t	t	t	t	t	
	34	47	71	86	87	-	87		
	38	40	60	81	86	-	86		
	42	34	52	71	83	-	83		
<b>SWSL 72 m</b>	46	29	46	63	79	80	80	80	
	50	25	41	56	71	77	77	77	
	54	22	36	50	64	74	74	74	
	58	19	32	45	58	71	71	71	
	62	16	29	41	53	65	65	65	
	66	14	26	38	49	58	58	58	
	70	12	24	34	45	51	51	51	
	74	11	22	32	42	44	44	44	

m	SL						
	0	50	100	150	200	250	225
t	t	t	t	t	t	t	t
20	109	153	197	218	218	-	218
22	95	135	174	213	218	-	218
24	84	120	155	191	211	-	211
26	76	108	140	172	203	203	203
<b>SWSL 36 m</b>	28	68	98	127	157	186	194
	30	62	89	117	144	171	186
	34	52	76	99	123	146	159
	38	45	66	86	107	128	129

m	SL						
	0	50	100	150	200	225	
t	t	t	t	t	t	t	
34	46	62	63	-	-	64	64
38	38	59	63	-	-	64	64
42	33	51	63	63	-	63	63
46	28	45	61	62	-	62	62
<b>SWSL 84 m</b>	50	24	39	55	61	-	61
	54	20	35	49	60	60	60
	58	18	31	44	57	60	60
	62	15	28	40	52	59	59
	66	13	25	36	48	58	58
	70	11	22	33	44	54	54
	74	9	20	30	40	48	48
	78	8	18	28	37	43	43
	82	7	16	26	35	38	38
	86	5	15	24	32	33	33

m	SL						
	0	50	100	150	200	250	225
t	t	t	t	t	t	t	t
24	83	118	153	162	-	-	162
26	74	106	138	162	162	-	162
<b>SWSL 48 m</b>	28	67	96	125	155	160	160
	30	60	88	115	142	157	157
	34	51	74	98	121	145	149
	38	43	64	85	105	126	139
	42	37	56	74	93	111	120
	46	33	49	66	83	100	103
	50	29	44	59	75	87	87

m	SL						
	0	50	100	150	200	225	
t	t	t	t	t	t	t	
28	65	94	119	120	-	120	
30	59	86	113	120	-	120	
34	49	72	96	117	117	117	
38	41	62	83	104	112	112	
<b>SWSL 60 m</b>	42	36	54	73	91	106	
	46	31	48	64	81	98	
	50	27	42	58	73	88	
	54	24	38	52	66	80	
	58	21	34	47	60	70	
	62	19	31	43	55	60	

# Lifting capacities luffing fly jib with SL, main boom 85° Tragfähigkeiten wippbarer Hilfsausleger mit SL, Hauptausleger 85° Capacités de levage fléchette à volée variable avec SL, flèche 85°

160 t   8,40 m SL-Radius 15 m 360° DIN/ISO

60 m		Main boom · Hauptausleger · Flèche principale										Fly jib · Hilfsausleger · Fléchette							
	Fly jib Hilfsausleger Fléchette	Radius Ausladung Portée	SL								Fly jib Hilfsausleger Fléchette	Radius Ausladung Portée	SL						
			0	50	100	150	200	225	0				50	100	150	200	225		
		m	t	t	t	t	t	t			m	t	t	t	t	t	t		
		20	106	150	176	178	-	178			38	37	56	56	-	-	57		
		22	93	132	172	178	-	178			42	31	50	56	57	-	57		
		24	82	118	153	176	176	176			46	27	43	56	56	-	56		
		26	74	106	138	170	171	171			50	23	38	53	55	-	55		
		28	67	96	125	155	165	165			54	19	34	48	54	-	54		
<b>SWSL</b>	<b>36 m</b>	30	61	88	115	142	160	160		<b>SWSL</b>	<b>84 m</b>	58	16	30	43	53	53		
		34	51	74	98	121	145	149			62	14	27	39	51	52	52		
		38	44	64	85	106	126	137			66	12	24	35	47	51	51		
		42	38	56	75	93	109	109			70	10	21	32	43	49	49		
											74	8	19	29	40	48	48		
											78	7	17	27	37	44	44		
											82	6	15	25	34	39	39		
											86	5	14	23	32	34	34		

			0	50	100	150	200	250	225
		m	t	t	t	t	t	t	t
		24	80	116	133	135	-	-	135
		26	72	104	133	135	-	-	135
<b>SWSL</b>	<b>48 m</b>	28	65	94	124	135	-	-	135
		30	59	86	113	132	132	-	132
		34	49	73	96	120	126	-	126
		38	42	63	83	104	119	-	119
		42	36	55	73	92	110	113	113
		46	31	48	65	82	98	107	107
		50	28	43	58	74	89	92	92
		54	25	39	53	67	75	-	75

			0	50	100	150	200	225
		m	t	t	t	t	t	t
		28	63	92	101	-	-	102
		30	57	84	101	102	-	102
<b>SWSL</b>	<b>60 m</b>	34	47	71	94	101	-	101
		38	40	61	81	98	98	98
		42	34	53	71	90	95	95
		46	30	46	63	80	91	91
		50	26	41	56	72	86	86
		54	23	37	51	65	79	82
		58	20	33	46	59	72	73
		62	17	30	42	54	63	63

			0	50	100	150	200	225
		m	t	t	t	t	t	t
		34	45	69	76	-	-	77
		38	38	59	76	76	-	76
		42	32	51	70	74	-	74
		46	28	45	61	72	-	72
<b>SWSL</b>	<b>72 m</b>	50	24	39	55	70	70	70
		54	21	35	49	63	68	68
		58	18	31	44	57	66	66
		62	15	28	40	52	63	63
		66	13	25	37	48	59	60
		70	11	23	34	44	53	53
		74	10	20	31	41	46	46

Remarks · Bemerkungen · Remarques

Superlift mast · Superlift-Mast · Mât Superlift 30 m

[MAIN MENU](#)

[Inhalt](#)

[Contents](#)

[Contenu](#)

160 t



8,40 m

SL-Radius 15 m

360°

DIN/ISO

72 m Main boom · Hauptausleger · Flèche principale

		Radius	/SL					
Fly jib		Ausladung						
Hilfsausleger		Portée	0	50	100	150	200	225
Flèche		t	t	t	t	t	t	t
	m	t	t	t	t	t	t	t
	26	70	102	104	-	-	-	106
	28	63	92	104	106	-	-	106
	30	57	84	104	105	-	-	105
SWSL	48 m	34	47	71	94	101	-	101
		38	40	61	82	97	-	97
	42	35	53	72	90	92	-	92
	46	30	47	64	80	88	-	88
	50	26	42	57	72	84	-	84
	54	23	37	51	66	80	-	80

		0	50	100	150	200	225	
m		t	t	t	t	t	t	
	30	55	80	81	-	-	82	
	34	46	69	81	81	-	81	
SWSL	60 m	38	38	59	78	79	-	79
		42	33	51	70	76	-	76
	46	28	45	62	73	73	73	
	50	25	40	55	70	71	71	
	54	21	36	50	64	69	69	
	58	19	32	45	58	66	66	
	62	16	29	41	53	64	64	
	66	14	26	37	49	56	56	

		0	50	100	150	200	175	
m		t	t	t	t	t	t	
	34	44	61	62	-	-	63	
	38	37	57	62	-	-	63	
	42	31	50	61	61	-	61	
	46	26	43	59	60	-	60	
SWSL	72 m	50	22	38	53	58	-	58
		54	19	34	48	56	56	56
	58	16	30	43	54	54	54	
	62	14	27	39	51	53	53	
	66	12	24	36	47	51	51	
	70	10	22	33	43	49	48	
	74	9	19	30	40	47	45	
	78	7	18	28	37	41	41	

		0	50	100	150	200	175	
m		t	t	t	t	t	t	
	38	34	47	47	-	-	48	
	42	29	47	47	-	-	48	
	46	24	42	47	47	-	47	
	50	21	37	46	46	-	46	
SWSL	84 m	54	18	33	45	46	-	46
		58	15	29	42	45	-	45
	62	13	25	38	44	44	44	
	66	11	23	34	43	43	43	
	70	9	20	31	42	42	42	
	74	7	18	29	39	40	40	
	78	6	16	26	36	39	39	
	82	5	14	24	33	38	38	
	86	4	13	22	31	36	35	
	90	-	11	20	29	30	30	

MAIN MENU



Inhalt

Contents

Contenu

# Lifting capacities luffing fly jib with SL, main boom 85° Tragfähigkeiten wippbarer Hilfsausleger mit SL, Hauptausleger 85° Capacités de levage fléchette à volée variable avec SL, flèche 85°

160 t   8,40 m SL-Radius 15 m 360° DIN/ISO

84 m Main boom · Hauptausleger · Flèche principale		 				
Fly jib Hilfsausleger Fléchette	Radius Ausladung Portée					
t	t	0	50	100	150	175
m	t	t	t	t	t	t
SWSL 60 m	30	52	61	62	-	64
	34	43	61	62	-	64
	38	37	57	61	-	62
	42	31	50	59	59	59
	46	27	44	56	57	57
	50	23	39	54	55	55
	54	20	34	48	52	52
	58	17	31	44	50	50
	62	15	28	40	48	48
	66	13	25	36	46	46
SWSL 72 m	34	40	48	48	-	49
	38	33	48	48	-	49
	42	28	47	47	-	48
	46	24	42	46	47	47
	50	21	37	45	45	45
	54	18	32	43	44	44
	58	15	29	42	42	42
	62	13	26	38	41	41
	66	11	23	34	39	39
	70	9	20	31	38	38
74	8	18	29	37	37	
78	6	16	26	36	36	
SWSL 84 m	38	31	38	39	-	40
	42	26	38	39	-	40
	46	22	38	38	-	39
	50	18	35	38	38	38
	54	15	31	37	37	37
	58	13	27	36	36	36
	62	11	24	35	35	35
	66	9	21	33	34	34
	70	8	19	30	33	33
	74	6	17	27	32	32
78	5	15	25	31	31	
82	-	13	23	29	29	
86	-	12	21	28	28	
90	-	10	19	27	27	

Remarks · Bemerkungen · Remarques

Superlift mast · Superlift-Mast · Mât Superlift 30 m

MAIN MENU

Inhalt

Contents

Contenu

# Working ranges fixed fly jib with SL, 15° Arbeitsbereiche starrer Hilfsausleger mit SL, 15° Portées fléchette fixe avec SL, 15°

SFSL

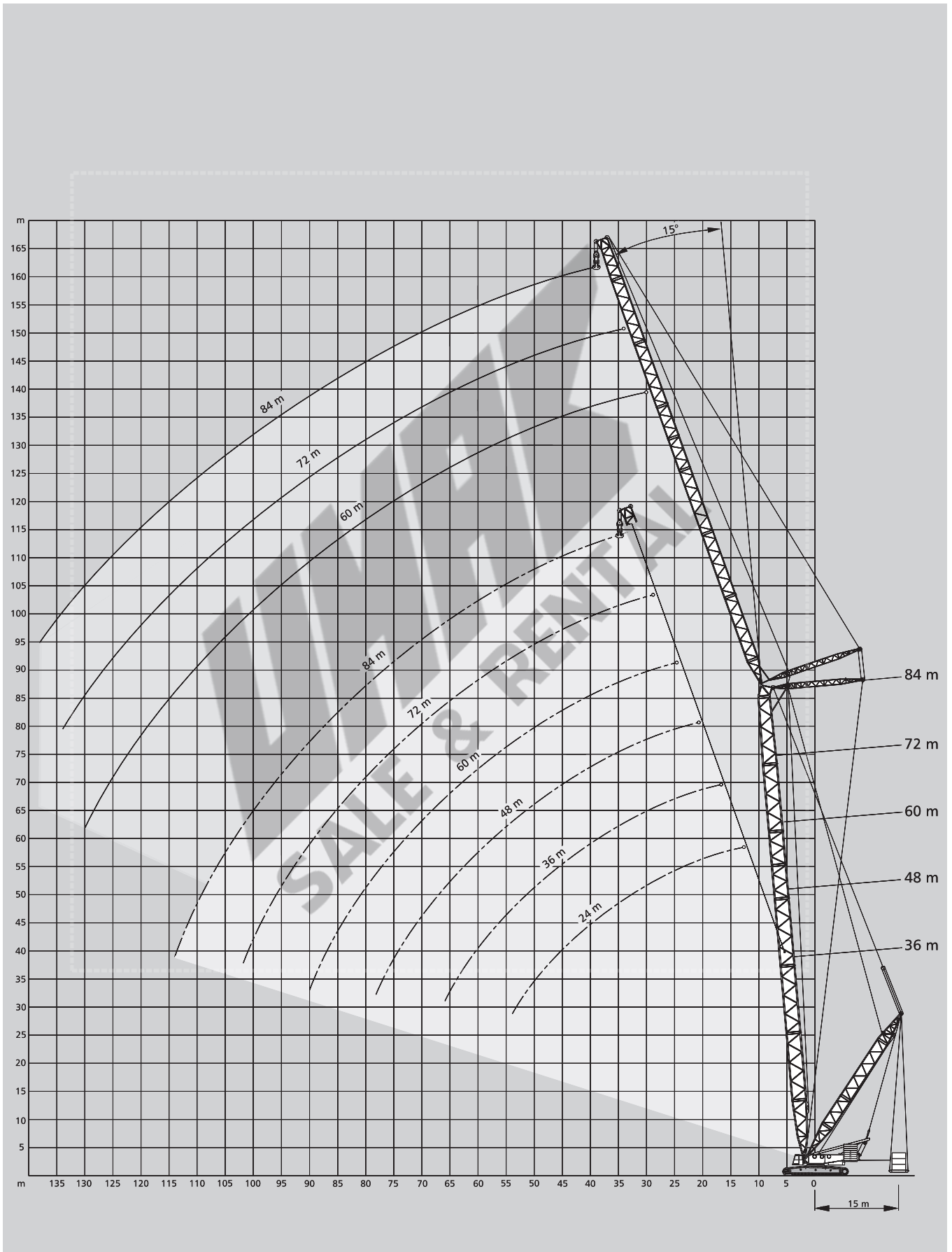

[MAIN MENUE](#)

[Inhalt](#)

[Contents](#)



[Contenu](#)

# Lifting capacities fixed fly jib with SL, 15°



## Tragfähigkeiten starrer Hilfsausleger mit SL, 15°

### Capacités de levage fléchette fixe avec SL, 15°



160 t   8,40 m SL-Radius 15 m 360° DIN/ISO

36 m Main boom · Hauptausleger · Flèche principale										
Fly jib Hilfsausleger Fléchette	Radius Ausladung Portée									
		t	0	50	100	150	200	250	300	
	m	t	t	t	t	t	t	t	t	t
	16	148	208	267	300	300	-	-	300	
	18	123	174	225	275	300	300	-	300	
	20	104	149	193	237	282	285	-	285	
	22	90	129	168	208	247	264	-	264	
	24	78	113	149	184	220	243	-	243	
	26	69	101	133	165	197	224	-	224	
	28	61	90	119	149	178	208	208	208	
SFSL	24 m	30	54	81	108	135	162	190	193	193
		34	43	67	90	114	137	161	166	166
		38	35	56	76	97	118	138	-	142
		42	28	47	65	84	102	121	-	122
		46	23	40	57	73	90	105	-	105
		50	18	34	49	65	80	92	-	92
		54	14	29	43	57	71	83	-	83



  

36 m Main boom · Hauptausleger · Flèche principale										
Fly jib Hilfsausleger Fléchette	Radius Ausladung Portée									
		t	0	50	100	150	200	250	300	
	m	t	t	t	t	t	t	t	t	t
	20	107	152	196	240	252	-	-	252	
	22	92	132	171	210	245	245	-	245	
	24	81	116	151	187	222	233	-	233	
	26	71	103	135	167	199	221	-	221	
	28	63	92	122	151	180	207	-	207	
	30	56	83	110	137	164	192	193	193	
SFSL	36 m	34	45	68	92	115	139	162	170	170
		38	37	57	78	99	119	140	151	151
		42	30	49	67	86	104	123	134	134
		46	24	41	58	75	92	108	119	119
		50	20	36	51	66	81	97	105	105
		54	16	31	45	59	73	87	93	93
		58	12	26	39	52	65	78	82	82
		62	9	22	35	47	59	71	73	73
		66	7	19	31	42	54	63	-	63



  

36 m Main boom · Hauptausleger · Flèche principale										
Fly jib Hilfsausleger Fléchette	Radius Ausladung Portée									
		t	0	50	100	150	200	250	300	
	m	t	t	t	t	t	t	t	t	t
	20	107	152	196	240	252	-	-	252	
	22	92	132	171	210	245	245	-	245	
	24	81	116	151	187	222	233	-	233	
	26	71	103	135	167	199	221	-	221	
	28	63	92	122	151	180	207	-	207	
	30	56	83	110	137	164	192	193	193	
SFSL	36 m	34	45	68	92	115	139	162	170	170
		38	37	57	78	99	119	140	151	151
		42	30	49	67	86	104	123	134	134
		46	24	41	58	75	92	108	119	119
		50	20	36	51	66	81	97	105	105
		54	16	31	45	59	73	87	93	93
		58	12	26	39	52	65	78	82	82
		62	9	22	35	47	59	71	73	73
		66	7	19	31	42	54	63	-	63

36 m Main boom · Hauptausleger · Flèche principale										
Fly jib Hilfsausleger Fléchette	Radius Ausladung Portée									
		t	0	50	100	150	200	250	300	
	m	t	t	t	t	t	t	t	t	t
	24	82	117	153	186	186	-	-	186	
	26	72	104	136	168	185	-	-	185	
	28	64	93	123	152	181	183	-	183	
	30	57	84	111	138	165	181	-	181	
	34	46	69	93	116	140	163	-	164	
	38	37	58	79	99	120	141	-	143	
	42	31	49	68	86	105	123	129	129	
	46	25	42	59	75	92	109	116	116	
SFSL	48 m	50	20	36	51	66	82	97	104	104
		54	16	31	45	59	73	87	93	93
		58	12	26	40	53	66	79	83	83
		62	9	22	35	47	59	71	74	74
		66	7	19	31	42	54	65	67	67
		70	5	16	27	38	49	60	60	60
		74	-	13	24	35	45	55	55	55
		78	-	11	21	31	41	46	-	46

36 m Main boom · Hauptausleger · Flèche principale										
Fly jib Hilfsausleger Fléchette	Radius Ausladung Portée									
		t	0	50	100	150	200	250	300	
	m	t	t	t	t	t	t	t	t	t
	38	38	58	68	69	-	-	-	69	
	42	31	49	68	68	-	-	-	68	
	46	25	42	59	68	-	-	-	68	
	50	20	36	51	66	67	-	-	67	
	54	16	31	45	59	66	-	-	66	
	58	12	26	39	52	64	64	-	64	
	62	9	22	35	47	59	62	-	62	
	66	6	18	30	42	53	60	-	60	
SFSL	84 m	70	4	15	27	38	48	57	-	57
		74	-	13	23	34	44	54	55	55
		78	-	10	20	30	40	50	52	52
		82	-	8	17	27	37	46	50	50
		86	-	6	15	24	33	42	47	46
		90	-	4	13	22	30	39	44	43
		84	-	-	11	19	27	36	39	39
		98	-	-	9	17	25	33	35	35
		102	-	-	7	15	23	30	30	30
		106	-	-	6	13	20	26	26	26
		110	-	-	4	11	18	22	22	22
		114	-	-	-	10	16	17	-	17

Remarks · Bemerkungen · Remarques

Superlift mast · Superlift-Mast · Mât Superlift 30 m

MAIN MENUE

Inhalt

Contents

Contenu







# Lifting capacities fixed fly jib with SL, 15°

## Tragfähigkeiten starrer Hilfsausleger mit SL, 15°

### Capacités de levage fléchette fixe avec SL, 15°

160 t   8,40 m SL-Radius 15 m 360° DIN/ISO

60 m Main boom · Hauptausleger · Flèche principale										
Fly jib Hilfsausleger Fléchette	Radius Ausladung Portée	SL								
		t	0	50	100	150	200	250	300	325
	m	t	t	t	t	t	t	t	t	
	22	90	129	168	178	-	-	-	178	
	24	77	113	148	178	178	-	-	178	
	26	67	99	131	163	178	-	-	178	
	28	59	88	118	147	176	178	-	178	
	30	52	79	106	133	160	178	-	178	
	34	40	64	87	111	134	158	167	167	
	38	31	52	73	94	114	135	155	155	
SFSL	36 m	42	24	43	62	80	99	117	136	142
	46	18	36	53	69	86	103	120	128	
	50	13	29	45	61	76	91	106	114	
	54	9	24	39	53	67	81	95	102	
	58	5	19	33	47	60	73	86	92	
	62	-	15	28	41	53	65	77	82	
	66	-	12	24	36	48	59	70	72	
	70	-	9	20	31	43	53	62	62	
	74	-	6	17	27	38	48	54	54	
	78	-	-	14	24	34	44	48	48	
	82	-	-	11	21	30	40	42	42	
	86	-	-	9	18	27	36	39	39	
		0	50	100	150	200	250	300	325	
	m	t	t	t	t	t	t	t	t	
	26	69	101	133	135	-	-	-	135	
	28	61	90	119	135	-	-	-	135	
	30	53	80	108	135	135	-	-	135	
	34	42	65	89	112	135	135	-	135	
	38	33	54	74	95	116	132	-	132	
	42	25	44	63	81	100	118	127	127	
	46	19	37	54	70	87	104	120	120	
	50	14	30	46	61	77	92	107	110	
SFSL	48 m	54	10	25	40	54	68	82	96	101
	58	6	20	34	47	60	73	86	92	
	62	-	16	29	42	54	66	78	84	
	66	-	12	24	36	48	59	71	76	
	70	-	9	20	32	43	54	64	69	
	74	-	6	17	28	38	49	59	62	
	78	-	4	14	24	34	44	54	56	
	82	-	-	11	21	30	40	49	51	
	86	-	-	9	18	27	36	45	46	
	90	-	-	7	15	24	33	41	41	
	94	-	-	5	13	21	29	36	36	
	98	-	-	-	11	19	27	30	30	
		0	50	100	150	200	250	300	325	
	m	t	t	t	t	t	t	t	t	
	30	55	82	101	102	-	-	-	102	
	34	43	66	90	102	-	-	-	102	
	38	34	55	75	96	102	-	-	102	
	42	26	45	64	82	101	101	-	101	
	46	20	38	54	71	88	100	-	100	
	50	15	31	47	62	77	92	100	100	
	54	10	25	40	54	68	82	93	93	
	58	7	20	34	48	61	74	87	87	
SFSL	60 m	62	-	16	29	42	54	66	78	81
	66	-	13	25	37	48	60	71	74	
	70	-	9	21	32	43	54	65	69	
	74	-	7	17	28	39	49	59	63	
	78	-	4	14	24	34	44	54	58	
	82	-	-	11	21	31	40	49	53	
	86	-	-	9	18	27	36	45	48	
	90	-	-	7	15	24	33	41	44	
	94	-	-	5	13	21	29	38	40	
	98	-	-	-	11	19	26	34	35	
	102	-	-	-	9	16	24	30	30	
	106	-	-	-	7	14	21	26	26	
	110	-	-	-	5	12	19	21	21	

Fly jib Radius SL										
Fly jib Hilfsausleger Fléchette	Radius Ausladung Portée	SL								
		t	0	50	100	150	200	250	300	325
	m	t	t	t	t	t	t	t	t	
	34	44	67	76	-	-	-	-	77	
	38	34	55	76	77	-	-	-	77	
	42	27	46	64	77	77	-	-	77	
	46	20	38	55	71	76	-	-	76	
	50	15	31	47	62	75	75	-	75	
	54	11	26	40	54	69	74	-	74	
	58	7	21	34	48	61	72	-	72	
	62	-	16	29	42	54	66	69	69	
	66	-	13	25	37	48	60	65	65	
	70	-	9	21	32	43	54	62	62	
SFSL	72 m	74	-	7	17	28	39	49	58	58
	78	-	4	14	24	34	44	54	55	
	82	-	-	11	21	30	40	49	52	
	86	-	-	9	18	27	36	45	48	
	90	-	-	7	15	24	33	41	45	
	94	-	-	4	13	21	29	38	41	
	98	-	-	-	10	18	26	34	37	
	102	-	-	-	8	16	24	31	33	
	106	-	-	-	6	14	21	28	29	
	110	-	-	-	5	12	19	25	25	
	114	-	-	-	10	17	21	21	21	
	118	-	-	-	8	15	17	17	17	
	122	-	-	-	6	13	14	14	14	
		0	50	100	150	200	250	300	325	
	m	t	t	t	t	t	t	t	t	
	38	36	56	56	-	-	-	-	57	
	42	28	47	56	57	-	-	-	57	
	46	21	39	56	57	-	-	-	57	
	50	16	32	48	57	57	-	-	57	
	54	11	26	41	55	56	-	-	56	
	58	7	21	35	48	55	-	-	55	
	62	4	17	30	43	55	55	-	55	
	66	-	13	25	37	49	53	-	53	
	70	-	10	21	33	44	51	-	51	
	74	-	7	18	28	39	49	50	50	
SFSL	84 m	78	-	4	15	25	35	45	48	48
	82	-	-	12	21	31	40	46	46	
	86	-	-	9	18	27	36	44	44	
	90	-	-	7	16	24	33	42	42	
	94	-	-	5	13	21	30	38	40	
	98	-	-	-	11	19	27	35	38	
	102	-	-	-	9	16	24	31	35	
	106	-	-	-	7	14	21	29	31	
	110	-	-	-	5	12	19	26	27	
	114	-	-	-	10	17	24	24	24	
	118	-	-	-	8	15	21	21	21	
	122	-	-	-	7	13	17	17	17	
	126	-	-	-	5	11	14	14	14	
	130	-	-	-	-	9	11	11	11	
	134	-	-	-	-	8	8	8	8	

160 t



8,40 m

SL-Radius 15 m

360°

DIN/ISO

## 72 m Main boom · Hauptausleger · Flèche principale

Fly jib Hilfsausleger Fléchette	Radius Ausladung Portée	SL							
		0	50	100	150	200	250	300	325
m	t	t	t	t	t	t	t	t	t
28	59	89	104	106	-	-	-	106	
30	52	79	104	106	-	-	-	106	
34	40	63	87	106	106	-	-	106	
38	30	52	72	93	106	-	-	106	
42	23	42	61	79	98	106	-	106	
46	16	34	51	68	85	102	106	106	
50	11	28	44	59	74	90	101	101	
54	7	22	37	51	65	79	94	94	
58	-	17	31	45	58	71	84	87	
62	-	13	26	39	51	63	75	80	
66	-	9	21	33	45	57	68	74	
SFSL 48 m	70	-	6	17	29	40	51	62	67
	74	-	-	14	25	35	46	56	61
	78	-	-	11	21	31	41	51	56
	82	-	-	8	18	27	37	46	51
	86	-	-	6	15	24	33	42	46
	90	-	-	-	12	21	29	38	41
	84	-	-	-	10	18	26	34	36
	98	-	-	-	7	15	23	31	32
	102	-	-	-	5	13	21	27	27
	106	-	-	-	-	11	18	23	23
	110	-	-	-	-	9	16	18	18

Fly jib Hilfsausleger Fléchette	Radius Ausladung Portée	SL							
		0	50	100	150	200	250	300	325
m	t	t	t	t	t	t	t	t	t
38	33	54	62	63	-	-	-	63	
42	25	44	62	63	-	-	-	63	
46	18	36	53	63	63	-	-	63	
50	13	29	45	60	63	-	-	63	
54	8	23	38	52	63	63	-	63	
58	4	18	32	46	59	61	-	61	
62	-	14	27	40	52	59	-	59	
66	-	10	22	34	46	56	56	56	
70	-	7	18	29	41	52	54	54	
74	-	4	15	25	36	47	52	52	
78	-	-	11	21	32	42	49	49	
SFSL 72 m	82	-	-	8	18	28	37	47	47
	86	-	-	6	15	24	33	42	44
	90	-	-	-	12	21	30	38	42
	84	-	-	-	10	18	26	35	38
	98	-	-	-	7	15	23	31	35
	102	-	-	-	5	13	21	28	31
	106	-	-	-	-	11	18	25	27
	110	-	-	-	-	9	16	23	24
	114	-	-	-	-	7	13	20	21
	118	-	-	-	-	5	11	17	17
	122	-	-	-	-	-	10	14	14
	126	-	-	-	-	-	8	11	11
	130	-	-	-	-	-	6	8	8
	134	-	-	-	-	-	5	5	5

	0	50	100	150	200	250	300	325	
m	t	t	t	t	t	t	t	t	
34	41	65	81	82	-	-	-	82	
38	32	53	74	82	-	-	-	82	
42	24	43	62	80	82	-	-	82	
46	18	35	52	69	82	-	-	82	
50	12	28	45	60	75	82	-	82	
54	8	23	38	52	66	80	81	81	
58	4	18	32	45	58	71	77	77	
62	-	13	26	39	52	64	72	72	
66	-	10	22	34	46	57	68	68	
70	-	7	18	29	41	52	62	63	
SFSL 60 m	74	-	4	14	25	36	46	57	59
	78	-	-	11	21	31	41	51	55
	82	-	-	8	18	28	37	47	51
	86	-	-	6	15	24	33	42	47
	90	-	-	-	12	21	30	38	43
	84	-	-	-	10	18	26	35	38
	98	-	-	-	7	15	23	31	34
	102	-	-	-	5	13	21	28	30
	106	-	-	-	-	11	18	25	26
	110	-	-	-	-	9	16	22	22
	114	-	-	-	-	7	14	18	18
	118	-	-	-	-	5	12	15	15
	122	-	-	-	-	-	10	11	11

	0	50	100	150	200	250	300	325	
m	t	t	t	t	t	t	t	t	
42	25	45	47	-	-	-	-	48	
46	19	37	47	48	-	-	-	48	
50	14	30	46	48	-	-	-	48	
54	9	24	39	48	48	-	-	48	
58	5	19	33	47	48	-	-	48	
62	-	15	28	41	47	47	-	47	
66	-	11	23	35	46	46	-	46	
70	-	8	19	30	41	45	-	45	
74	-	5	15	26	37	44	44	44	
78	-	-	12	22	32	42	42	42	
SFSL 84 m	82	-	-	9	19	28	38	41	41
	86	-	-	6	16	25	34	40	40
	90	-	-	4	13	21	30	38	38
	84	-	-	-	10	18	27	35	36
	98	-	-	-	8	16	24	32	35
	102	-	-	-	6	13	21	29	32
	106	-	-	-	4	11	18	26	28
	110	-	-	-	-	9	16	23	25
	114	-	-	-	-	7	14	21	22
	118	-	-	-	-	5	12	18	19
	122	-	-	-	-	-	10	16	16
	126	-	-	-	-	-	8	14	14
	130	-	-	-	-	-	6	11	11
	134	-	-	-	-	-	5	8	8
	138	-	-	-	-	-	6	6	6

Remarks · Bemerkungen · Remarques

Superlift mast · Superlift-Mast · Mât Superlift 30 m

MAIN MENU

Inhalt

Contents



Contenu

# Lifting capacities fixed fly jib with SL, 15°





## Tragfähigkeiten starrer Hilfsausleger mit SL, 15°



### Capacités de levage fléchette fixe avec SL, 15°

160 t   8,40 m SL-Radius 15 m 360° DIN/ISO

84 m Main boom · Hauptausleger · Flèche principale										
Fly jib Hilfsausleger Fléchette	Radius Ausladung Portée	SL 								
		t	0	50	100	150	200	250	300	
	m	t	t	t	t	t	t	t	t	t
	34	39	61	61	-	-	-	-	-	62
	38	30	51	61	62	-	-	-	-	62
	42	22	42	60	62	-	-	-	-	62
	46	15	33	50	62	62	-	-	-	62
	50	10	26	42	58	62	-	-	-	62
	54	5	20	35	50	62	62	-	-	62
	58	-	15	29	43	56	61	-	-	61
	62	-	11	24	37	49	58	58	-	58
	66	-	7	19	31	43	55	56	-	56
	70	-	4	15	26	38	49	53	-	53
	74	-	-	11	22	33	43	51	-	51
SFSL	60 m	78	-	-	8	18	28	39	48	48
		82	-	-	5	15	25	34	44	46
		86	-	-	-	12	21	30	39	43
		90	-	-	-	9	18	27	35	38
		84	-	-	-	7	15	23	32	35
		98	-	-	-	4	12	20	28	31
		102	-	-	-	-	10	17	25	27
		106	-	-	-	-	8	15	22	24
		110	-	-	-	-	6	13	20	20
		114	-	-	-	-	4	10	17	17
		118	-	-	-	-	-	8	14	14
		122	-	-	-	-	-	7	11	11
		126	-	-	-	-	-	5	8	8
		130	-	-	-	-	-	-	5	5

Fly jib Radius Hilfsausleger Ausladung Fléchette Portée										
SL 	SL 	SL 								
		t	0	50	100	150	200	250	300	
		m	t	t	t	t	t	t	t	t
		42	23	38	38	-	-	-	-	38
		46	16	36	38	-	-	-	-	38
		50	11	28	38	38	-	-	-	38
		54	6	22	37	38	-	-	-	38
		58	-	17	31	38	38	-	-	38
		62	-	12	25	38	38	-	-	38
		66	-	9	21	33	38	38	-	38
		70	-	5	16	28	37	37	-	37
		74	-	-	13	23	34	37	-	37
		78	-	-	9	19	30	36	36	36
		82	-	-	6	16	26	35	35	35
SFSL	84 m	86	-	-	4	13	22	31	34	34
		90	-	-	-	10	19	27	33	33
		84	-	-	-	7	16	24	32	32
		98	-	-	-	5	13	21	29	31
		102	-	-	-	-	10	18	26	27
		106	-	-	-	-	8	15	23	24
		110	-	-	-	-	6	13	20	21
		114	-	-	-	-	4	11	18	19
		118	-	-	-	-	-	9	15	16
		122	-	-	-	-	-	7	13	14
		126	-	-	-	-	-	5	11	11
		130	-	-	-	-	-	-	9	9
		134	-	-	-	-	-	-	6	6
		138	-	-	-	-	-	-	4	4

84 m Main boom · Hauptausleger · Flèche principale										
Fly jib Hilfsausleger Fléchette	Radius Ausladung Portée	SL 								
		t	0	50	100	150	200	250	300	
	m	t	t	t	t	t	t	t	t	t
	38	30	48	48	-	-	-	-	-	48
	42	22	43	48	48	-	-	-	-	48
	46	16	34	48	48	-	-	-	-	48
	50	10	27	43	48	-	-	-	-	48
	54	6	21	36	48	48	-	-	-	48
	58	-	16	30	43	48	-	-	-	48
	62	-	11	24	37	48	48	-	-	48
	66	-	7	20	32	44	46	-	-	46
	70	-	4	15	27	38	45	45	-	45
	74	-	-	12	22	33	44	44	-	44
SFSL	72 m	78	-	-	9	19	29	39	42	42
		82	-	-	6	15	25	34	40	40
		86	-	-	-	12	21	30	39	39
		90	-	-	-	9	18	27	35	37
		84	-	-	-	7	15	23	32	34
		98	-	-	-	4	12	20	28	30
		102	-	-	-	-	10	18	25	27
		106	-	-	-	-	8	15	22	24
		110	-	-	-	-	6	13	20	21
		114	-	-	-	-	4	10	17	18
		118	-	-	-	-	-	8	15	15
		122	-	-	-	-	-	6	12	12
		126	-	-	-	-	-	5	10	10
		130	-	-	-	-	-	-	7	7
		134	-	-	-	-	-	-	5	5

Remarks · Bemerkungen · Remarques

Superlift mast · Superlift-Mast · Mât Superlift 30 m

[MAIN MENUE](#)

[Inhalt](#)

[Contents](#)

[Contenu](#)

Working ranges fixed fly jib SFVL with SL, 13°  
Arbeitsbereiche starrer Hilfsausleger SFVL mit SL, 13°  
Portées fléchette fixe SFVL avec SL, 13°

SFVL

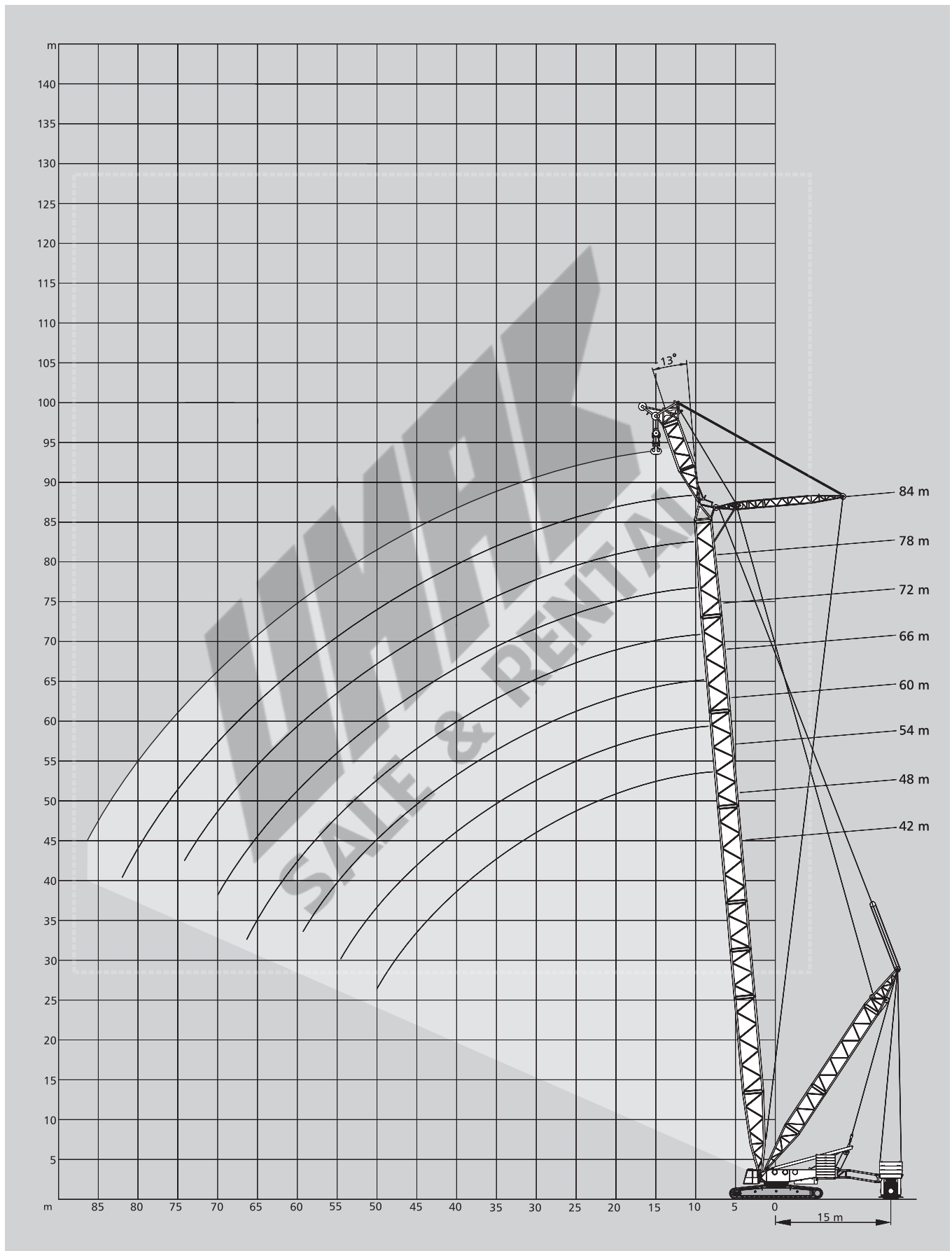

[MAIN MENU](#)

[Inhalt](#)

[Contents](#)

[Contenu](#)

# Lifting capacities fixed fly jib SFVL with Superlift

## Tragfähigkeiten starrer Hilfsausleger SFVL mit Superlift

### Capacités de levage fléchette fixe SFVL avec Superlift

160 t   8,40 m SL-Radius 15 m 360° DIN/ISO

42 m Main boom · Hauptausleger · Flèche principale					
Fly jib · Hilfsausleger · Fléchette					
12 m					
Radius Ausladung Portée	13°		20°		
	0	325	0	325	
m	t	t	t	t	
12	218,0	480,0	-	-	
14	168,0	458,0	170,0	438,0	
16	135,0	436,0	137,0	418,0	
18	112,0	394,0	113,0	394,0	
20	94,0	349,0	95,0	355,0	
22	80,0	317,0	81,0	318,0	
24	70,0	286,0	70,0	287,0	
SFVL 26	61,0	260,0	62,0	261,0	
28	53,0	239,0	54,0	239,0	
30	47,0	220,0	48,0	221,0	
34	37,0	189,0	38,0	190,0	
38	29,0	160,0	30,0	163,0	
42	23,0	137,0	23,0	139,0	
46	18,0	115,0	18,0	116,0	
50	14,0	94,0	-	-	
54	-	-	-	-	
58	-	-	-	-	

48 m Main boom · Hauptausleger · Flèche principale					
Fly jib · Hilfsausleger · Fléchette					
12 m					
Radius Ausladung Portée	13°		20°		
	0	325	0	325	
m	t	t	t	t	
12	217,0	430,0	-	-	
14	167,0	428,0	169,0	412,0	
16	134,0	417,0	136,0	401,0	
18	110,0	398,0	112,0	390,0	
20	93,0	352,0	94,0	353,0	
22	79,0	315,0	80,0	316,0	
24	68,0	284,0	69,0	285,0	
SFVL 26	59,0	258,0	60,0	259,0	
28	52,0	237,0	53,0	237,0	
30	46,0	218,0	46,0	219,0	
34	35,0	187,0	36,0	188,0	
38	27,0	163,0	28,0	163,0	
42	21,0	143,0	21,0	141,0	
46	16,0	124,0	16,0	121,0	
50	12,0	105,0	12,0	106,0	
54	9,0	88,0	-	-	
58	-	-	-	-	

54 m Main boom · Hauptausleger · Flèche principale					
m	t	t	t	t	
12	-	-	-	-	
14	166,0	387,0	169,0	369,0	
16	133,0	385,0	135,0	369,0	
18	109,0	383,0	111,0	366,0	
20	91,0	350,0	93,0	351,0	
22	78,0	313,0	79,0	314,0	
24	67,0	282,0	68,0	283,0	
26	58,0	257,0	59,0	258,0	
28	50,0	235,0	51,0	236,0	
SFVL 30	44,0	216,0	45,0	217,0	
34	34,0	185,0	34,0	186,0	
38	26,0	161,0	26,0	162,0	
42	19,0	141,0	20,0	142,0	
46	14,0	125,0	15,0	125,0	
50	10,0	111,0	10,0	110,0	
54	7,0	96,0	7,0	97,0	
58	-	81,0	-	82,0	
62	-	-	-	-	
66	-	-	-	-	
70	-	-	-	-	
74	-	-	-	-	
78	-	-	-	-	
82	-	-	-	-	

60 m Main boom · Hauptausleger · Flèche principale					
m	t	t	t	t	
12	-	-	-	-	
14	165,0	350,0	-	-	
16	132,0	348,0	134,0	334,0	
18	108,0	346,0	110,0	329,0	
20	90,0	341,0	92,0	324,0	
22	76,0	311,0	78,0	310,0	
24	65,0	280,0	66,0	281,0	
26	56,0	254,0	57,0	256,0	
28	49,0	233,0	50,0	234,0	
SFVL 30	42,0	214,0	43,0	215,0	
34	32,0	183,0	32,0	184,0	
38	23,0	159,0	24,0	160,0	
42	17,0	139,0	18,0	140,0	
46	12,0	123,0	12,0	123,0	
50	8,0	110,0	8,0	110,0	
54	-	97,0	5,0	99,0	
58	-	85,0	-	87,0	
62	-	74,0	-	74,0	
66	-	62,0	-	-	
70	-	-	-	-	
74	-	-	-	-	
78	-	-	-	-	
82	-	-	-	-	

Remarks · Bemerkungen · Remarques

Superlift mast · Superlift-Mast · Mât Superlift 30 m

MAIN MENU

Inhalt

Contents

Contenu

160 t



8,40 m

SL-Radius 15 m

360°

DIN/ISO

## 66 m Main boom · Hauptausleger · Flèche principale

Fly jib · Hilfsausleger · Fléchette

Radius Ausladung Portée	12 m			
	13°		20°	
	0	325	0	325
m	t	t	t	t
14	164,0	297,0	-	-
16	131,0	295,0	133,0	284,0
18	107,0	293,0	109,0	282,0
20	89,0	291,0	91,0	280,0
22	75,0	282,0	77,0	277,0
24	64,0	270,0	65,0	267,0
26	55,0	253,0	56,0	254,0
28	48,0	231,0	49,0	232,0
30	41,0	212,0	42,0	213,0
SFVL 34	30,0	182,0	31,0	182,0
38	22,0	158,0	23,0	158,0
42	16,0	138,0	16,0	139,0
46	10,0	122,0	11,0	122,0
50	6,0	108,0	7,0	109,0
54	-	97,0	-	97,0
58	-	87,0	-	88,0
62	-	77,0	-	78,0
66	-	67,0	-	67,0
70	-	57,0	-	-
74	-	-	-	-
78	-	-	-	-

## 72 m Main boom · Hauptausleger · Flèche principale

Fly jib · Hilfsausleger · Fléchette

Radius Ausladung Portée	12 m			
	13°		20°	
	0	325	0	325
m	t	t	t	t
14	-	-	-	-
16	130,0	259,0	132,0	252,0
18	106,0	258,0	108,0	250,0
20	88,0	257,0	89,0	249,0
22	74,0	254,0	75,0	247,0
24	63,0	246,0	64,0	242,0
26	54,0	239,0	55,0	235,0
28	46,0	229,0	47,0	229,0
30	39,0	210,0	40,0	211,0
SFVL 34	28,0	179,0	29,0	180,0
38	20,0	155,0	21,0	156,0
42	13,0	136,0	14,0	137,0
46	8,0	120,0	9,0	120,0
50	-	106,0	-	107,0
54	-	95,0	-	95,0
58	-	86,0	-	86,0
62	-	77,0	-	78,0
66	-	68,0	-	69,0
70	-	59,0	-	60,0
74	-	50,0	-	-
78	-	-	-	-

## 78 m Main boom · Hauptausleger · Flèche principale

m	t	t	t	t
16	129,0	219,0	-	-
18	105,0	217,0	107,0	211,0
20	87,0	215,0	88,0	209,0
22	73,0	213,0	74,0	207,0
24	61,0	211,0	63,0	205,0
26	52,0	208,0	54,0	203,0
28	44,0	205,0	46,0	200,0
30	38,0	202,0	39,0	197,0
34	27,0	178,0	28,0	179,0
SFVL 38	18,0	154,0	19,0	155,0
42	12,0	134,0	13,0	135,0
46	7,0	118,0	7,0	119,0
50	-	105,0	-	105,0
54	-	94,0	-	94,0
58	-	84,0	-	84,0
62	-	76,0	-	76,0
66	-	68,0	-	69,0
70	-	60,0	-	61,0
74	-	52,0	-	53,0
78	-	45,0	-	45,0
82	-	38,0	-	-
86	-	-	-	-
90	-	-	-	-

## 84 m Main boom · Hauptausleger · Flèche principale

m	t	t	t	t
16	128,0	194,0	-	-
18	103,0	192,0	106,0	187,0
20	85,0	190,0	87,0	185,0
22	71,0	189,0	73,0	183,0
24	60,0	186,0	62,0	182,0
26	51,0	183,0	52,0	179,0
28	43,0	179,0	44,0	176,0
30	36,0	176,0	37,0	172,0
34	25,0	165,0	26,0	164,0
SFVL 38	16,0	149,0	17,0	149,0
42	10,0	132,0	11,0	133,0
46	5,0	116,0	5,0	117,0
50	-	103,0	-	104,0
54	-	92,0	-	92,0
58	-	82,0	-	83,0
62	-	74,0	-	74,0
66	-	67,0	-	67,0
70	-	59,0	-	59,0
74	-	52,0	-	52,0
78	-	45,0	-	45,0
82	-	39,0	-	39,0
86	-	32,0	-	-
90	-	-	-	-

Remarks · Bemerkungen · Remarques

Superlift mast · Superlift-Mast · Mât Superlift 30 m

MAIN MENU

Inhalt

Contents

Contenu

Working ranges fixed fly jib SFVL with SL, 20°  
Arbeitsbereiche starrer Hilfsausleger SFVL mit SL, 20°  
Portées fléchette fixe SFVL avec SL, 20°

SFVL

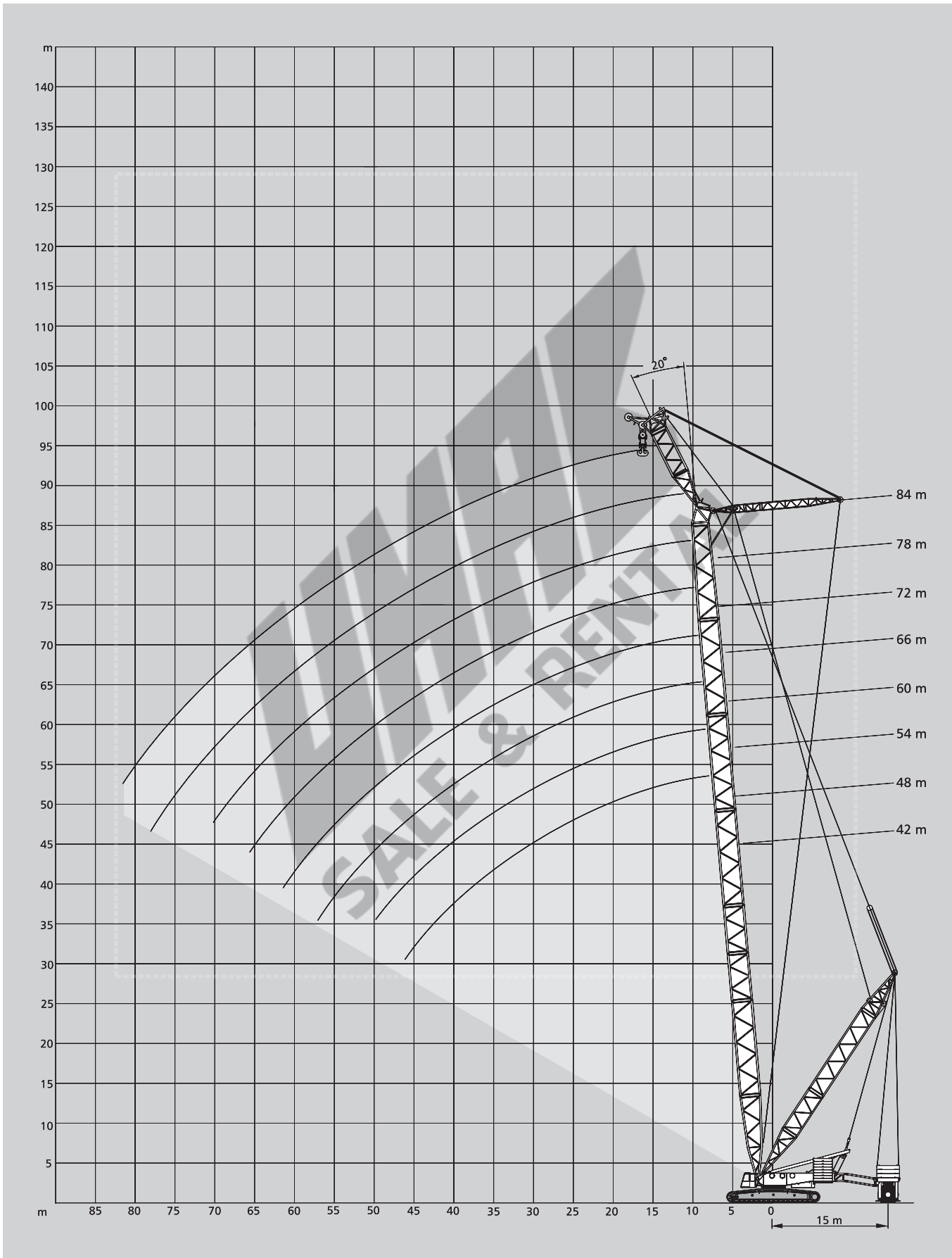

[MAIN MENUE](#)

[Inhalt](#)

[Contents](#)

[Contenu](#)

# Key Zeichenerklärung Légende

 Track · Spur · Voie

 Counterweight · Gegengewicht · Contrepoids

 Superlift counterweight · Superlift-Gegengewicht · Contrepoids Superlift

 Counterweight carrier · Gegengewichtswagen · Chariot-contrepoids

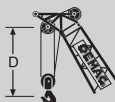
„D“  

S: heavy · schwer · lourd

L: light · leicht · léger

H: Main boom · Hauptausleger · Flèche principale

W: Luffing fly jib · Wippbarer Hilfsausleger · Fléchette à volée variable

F: Fixed fly jib · Starrer Hilfsausleger · Fléchette fixe

SL: Superlift

SGL: Heavy base length · Schwere Grundlänge · Longueur de base lourde

ZB: Central ballast · Zentralballast · Lest central

[MAIN MENU](#)

[Inhalt](#)

[Contents](#)

[Contenu](#)



# Technical description

## Crawler carrier

3-section carrier comprising of carbody and two crawlers. Hydraulic pin connections between crawlers and carbody provide for easy assembly and removal to minimise width and weight for transportation.

### Carbody

Bending- and torsion-resistant welded structure of box type construction, fabricated of high-strength fine-grain structural steel.

### Crawlers

Side frames: bending-resistant welded structure of high-strength fine-grain structural steel. Track shoes, idler and drive sprockets are fabricated of heat-treated high-strength cast steel. 15 rollers on each side frame with hardened rolling surfaces. Automatic centralized lubrication is included as standard.

### Power train

The tracks are powered by two hydraulic motors each through closed planetary gear reduction units running in oil bath, equipped with spring-applied hydraulically released holding brakes; the gear units are of very compact design to fit within the width of the crawlers. Each crawler is infinitely variable controlled, both independently and in opposite direction.

## Superstructure

### Counterweight

160 t.

### Frame

Torsion-resistant welded structure fabricated of high-strength fine-grain structural steel. Connected to carrier by triple-row roller bearing slew ring.

### Drive

DaimlerChrysler diesel engine type OM 502 LA, 380 kW (516 hp) at 2000 <sup>1</sup>/min, torque 2400 Nm at 1080 <sup>1</sup>/min. The engine complies with EUROMOT II and EPA 2 regulations. Pump distribution gearbox with five variable displacement axial piston pumps, and gear pumps.

### Rope drums

The standard superstructure equipment includes three rope drums – hoist 1, hoist 2 and boom hoist. The drums are powered by hydraulic motors through closed planetary gear units running in oil bath. All rope drums have spring-applied, hydraulically released multi-disk brakes and non-wearing hydraulic braking for load lowering. Rope ends H 1, 2, 3 and W 1, 2 equipped with quick-connect rope end fittings. Hoists H 1 + 2 are removable to minimise weight for transportation.

### Slew unit

Powered by hydraulic motor through closed, planetary gear unit running in oil bath. Spring-applied, hydraulically released holding brake and non-wearing hydraulic braking.

### Control

Electronic proportional valve pilot-control integrated into stored-program control system with fault-diagnosis. Automatic power control giving optimal utilisation of engine output.

### Cabin

Comfortable cab with large windscreen and airconditioner. Safety-glazing all around, roof window, self-contained hot air heater, full instrumentation and crane controls. The cab can be tilted back for improved operator view of boom point. A camera system is installed to monitor the rope drums. For transportation, the cab swings in front of the superstructure to minimise width.

### Electrical equipment:

24 V d. c. system.

## Optional equipment

### Counterweight

20 t on the superstructure (only in conjunction with central ballast).

### Central ballast:

60 t.

### Hydraulic raising system for A-frame

### Assembly jacks

Four hydraulic jacking cylinders on carbody (folding within 3 m width) for easy assembly of crawlers.

### Counterweight carrier

Drive 4 x 4, total weight max. 325 t.

### Quick-connection

Hydraulic quick-disconnect fittings on carrier and superstructure facilitate removal to minimise weight for transportation.

### Track shoes

2000 mm

## Boom configurations S and L

SH:	Main boom: foot section 10.5 m (used to install drums W1/H3), inserts 12 m and 6 m (type 2724) and tapered insert 12 m, head with sheave assembly 600 t 1.5 m. Main boom lengths: 24-84 m.
SH / LH:	Main boom: same as SH 60 m, extended by type 2421 from the fly jib and by top section 7.5 m. Main boom lengths: 66-102 m.
SW:	Main boom: same as SH. Fly jib: foot section 4.5 m, inserts 12 m and 6 m (type 2421) and top section 7.5 m. Main boom lengths: 30-66 m. Fly jib lengths: 24-84 m.
SSL:	Main boom: same as SH. Mast 30 m, radius 15 m (other radii on request), Superlift counterweight 0-300 t (at 50 t increments). Main boom lengths: 36-84 m.
SSL / LSL:	Main boom: same as SH 84 m, extended by type 2421 from the fly jib and by top section 7.5 m. Mast 30 m, radius 15 m (other radii on request), Superlift counterweight 0-300 t (at 50 t increments). Main boom lengths: 90-138 m.
SWSL: (SFSL)	Main boom: same as SH. Fly jib: same as SW. Mast 30 m, radius 15 m (other radii on request), Superlift counterweight 0-300 t (at 50 t increments). Main boom lengths: 36-84 m. Fly jib lengths: 24-84 m.
LF:	Main boom: same as SH, SH/LH. Fly jib: foot section 6 m, inserts 12 m (type 1813), top section 6 m. Main boom lengths: 30-96 m. Fly jib lengths: 12, 24, 36 m.
LFSL:	same as LF, but in conjunction with SL-attachment. Main boom lengths: 36-138 m. Fly jib lengths: 12, 24, 36 m.
SFVL:	Main boom: same as SH, lengths 42-84 m, without sheave assembly. Fly jib: foot section 4.5 m, insert 6 m; heavy-duty head 1.5 m. Sheave assembly 600 t same as SH.
Safety devices	Electronic safe load indicator, hoist limit switch, limit switches for boom movements, hydraulic boom backstops, anemometer.
Ancillary equipment	
Hoist H3	Additional rope drum on main boom (for LF or runner operation). Line pull same as H1, rope length 650 m.
Reeving winch	mounted on superstructure
Runner	approx. 2 m for installation on boom head or top section (not in conjunction with LF).

## Raupenunterwagen

Der Raupenunterwagen ist 3teilig und besteht aus dem Mittelstück und zwei Raupen. Mittelstück und Raupen werden hydraulisch verbolzt und sind demontierbar zum Erreichen günstiger Transportabmessungen und Gewichte.

### Mittelstück

Biege- und verwindungssteife Schweißkonstruktion in Zellenbauweise aus hochfestem Feinkornbaustahl.

### Raupen

Raupenträger: Biegesteife Schweißkonstruktion aus hochfestem Feinkornbaustahl. Bodenplatten der Raupenkettens, Turas und Leitrad aus vergütetem hochfestem Stahlguß. 15 Laufrollen je Raupe mit gehärteten Laufflächen. Zentralschmieranlage serienmäßig.

### Antrieb

Die Raupen werden von je zwei Hydromotoren über geschlossene, ölbadgeschmierte Planetengetriebe mit federbelasteten, hydraulisch gelüfteten Haltebremsen angetrieben, die Getriebe sind in besonders kompakter Bauform innerhalb der Raupenbreite angeordnet. Jede Seite ist stufenlos, einzeln und gegenläufig steuerbar.

## Oberwagen

### Gegengewicht

160 t.

### Rahmen

Verformungssteife Schweißkonstruktion aus hochfestem Feinkornbaustahl. Verbindung zum Unterwagen durch 3-reihige Rollendrehverbindung.

### Antrieb

DaimlerChrysler Dieselmotor Typ OM 502 LA, 380 kW (516 PS) bei 2000 <sup>1</sup>/min, Drehmoment 2400 Nm bei 1080 <sup>1</sup>/min. Der Motor erfüllt EUROMOT II und EPA 2-Vorschriften. Pumpenverteilergetriebe mit fünf verstellbaren Axialkolbenpumpen und zusätzlichen Zahnradpumpen.

### Seilwinden

Der Oberwagen ist serienmäßig mit drei Seilwinden – Hubwerk 1, Hubwerk 2 und Einziehwerk – ausgerüstet. Der Antrieb der Winden erfolgt durch Hydromotoren über geschlossene, ölbadgeschmierte Planetengetriebe. Alle Seilwinden sind mit federbelasteten, hydraulisch gelüfteten Lamellenbremsen und verschleißfreier, hydraulischer Bremsung für den Senkvorgang ausgerüstet. Die Seilenden H 1, 2, 3 und W 1, 2 sind mit Preßfitting und Taschen ausgestattet. Zur Reduzierung der Transportgewichte sind die Winden H 1 + 2 ausbaubar.

### Drehwerk

Ein Drehwerk mit Antrieb durch Hydromotor über geschlossenes, ölbadgeschmiertes Planetengetriebe. Federbelastete, hydraulisch gelüftete Haltebremse und verschleißfreie hydraulische Bremsung.

### Steuerung

Elektronische Proportionalventilvorsteuerung integriert in eine speicherprogrammierte Steuerung mit Fehlerdiagnose. Leistungsregelung zur optimalen Nutzung der Motorleistung.

### Kabine

Komfortkabine mit großem Frontfenster und Klimaanlage. Sicherheitsverglasung rundum, Dachfenster, motorunabhängige Warmluftheizung und Steuer- und Kontrollelemente für die Kranfunktionen. Die Kabine ist zur Sichtverbesserung nach hinten neigbar. Zur Überwachung der Winden im Oberwagen ist ein Kamerasystem installiert. Während des Transportes ist die Kabine vor den Oberwagen geschwenkt.

### Elektrische Anlage

24 V Gleichstrom.

## Zusatzausrüstung

### Gegengewicht

20 t am Oberwagen (nur in Verbindung mit Zentralballast)

### Zentralballast

60 t.

### Hydraulische Umlage A-Bock

### Montageabstützung

Vier hydraulische Stützzylinder am Mittelstück (in 3 m anklappbar) zur einfachen Montage der Raupen.

### Gegengewichtswagen

Antrieb 4 x 4, max. Gesamtgewicht 325 t.

### Quick-connection

Hydraulische Schnellverbindung Unterwagen/Oberwagen zur Reduzierung der Transportgewichte.

### Bodenplatten

2000 mm

## Auslegervarianten S und L

SH:	Hauptausleger: Fußstück 10,5 m (geeignet zum Einbau der Winde W1/H3), Zwischenstücke 12 m und 6 m (Typ 2724) und Reduzierstück 12 m, Kopf mit Rollensatz 600 t 1,5 m. Hauptauslegerlängen: 24-84 m.
SH / LH:	Hauptausleger: wie SH 60 m, verlängert mit Typ 2421 aus Hilfsausleger und Spitze 7,5 m. Hauptauslegerlängen: 66-102 m.
SW:	Hauptausleger: wie SH. Hilfsausleger: Fußstück 4,5 m, Zwischenstücke 12 m und 6 m (Typ 2421) und Spitze 7,5 m. Hauptauslegerlängen: 30-66 m. Hilfsauslegerlängen: 24-84 m.
SSL:	Hauptausleger: wie SH. Mast 30 m, Radius 15 m (andere auf Anfrage), Superliftgegengewicht 0-300 t (Stufung 50 t). Hauptauslegerlängen: 36-84 m.
SSL / LSL:	Hauptausleger: wie SH 84 m, verlängert mit Typ 2421 aus Hilfsausleger und Spitze 7,5 m. Mast 30 m, Radius 15 m (andere auf Anfrage), Superliftgegengewicht 0-300 t (Stufung 50 t). Hauptauslegerlängen: 90-138 m.
SWSL: (SFSL)	Hauptausleger: wie SH. Hilfsausleger: wie SW. Mast 30 m, Radius 15 m (andere auf Anfrage), Superliftgegengewicht 0-300 t (Stufung 50 t). Hauptauslegerlängen: 36-84 m. Hilfsauslegerlängen: 24-84 m.
LF:	Hauptausleger: wie SH, SH/LH. Hilfsausleger: Fußstück 6 m, Zwischenstücke 12 m (Typ 1813), Spitze 6 m. Hauptauslegerlängen: 30-96 m. Hilfsauslegerlängen: 12, 24, 36 m.
LFSL:	wie LF, jedoch in Verbindung mit SL-Einrichtung. Hauptauslegerlängen: 36-138 m. Hilfsauslegerlängen: 12, 24, 36 m.
SFVL:	Hauptausleger: wie SH, Längen 42-84 m, ohne Rollensatz. Hilfsausleger: Fußstück 4,5 m, Zwischenstück 6 m; Schwerlastkopf 1,5 m. Rollensatz 600 t wie SH.
Sicherheitseinrichtungen	Elektronischer Lastmomentbegrenzer, Hubendschalter, Endschalter für Auslegerbewegungen, hydraulische Ausleger-Rückfallsicherungen, Windmesser.
Zusatzausrüstung	
Seilwinde H3	Zusätzliche Seilwinde im Hauptausleger (zum Betrieb an LF oder Runner). Seilzug wie H1, Seillänge 650 m.
Einscherwinde	auf Oberwagen angebaut.
Runner	ca. 2 m zum Anbau an Kopf oder Spitze (nicht in Verbindung mit LF).

## Châssis à chenilles

Le châssis à chenilles consiste en trois parties – deux chenilles et la partie centrale. Les chenilles et la partie centrale sont verrouillées hydrauliquement facilitant ainsi le montage et démontage pour diminuer la largeur d'encombrement et le poids de transport.

### Partie centrale

Construction mécano-soudée, rigide à la flexion et à la torsion, sous forme de caissons en acier de construction de haute résistance à grains fins.

### Chenilles

Trains de chenille: construction mécano-soudée rigide à la flexion, réalisés en acier de construction de haute résistance à grains fins. Les patins des chenilles ainsi que les barbotins d'entraînement et les roues directrices sont en acier coulé de haute résistance, traité par trempe et revenu. Chaque chenille est équipée de 15 galets d'appui dont les surfaces de roulement sont trempées. Graissage centralisé automatique inclus de série.

### Entraînement

Les barbotins sont entraînés par deux moteurs hydrauliques et réducteurs planétaires, sous bain d'huile, en carter étanche, munis de freins d'arrêt à commande par ressorts, desserrés hydrauliquement. Grâce à leur compacité, les réducteurs s'intègrent complètement dans la largeur des chenilles. Chaque chenille permet un mouvement individuel et opposé.

## Partie tournante

### Contrepoids

160 t.

### Charpente

Structure mécano-soudée, rigide à la torsion, réalisée en acier de construction de haute résistance à grains fins. Couronne d'orientation à trois rangées de rouleaux servant de jonction entre la partie tournante et le châssis.

### Moteur et transmission

Moteur diesel DaimlerChrysler, type OM 502 LA, 380 kW (516 CV) à 2000 <sup>1</sup>/min, couple 2400 Nm à 1080 <sup>1</sup>/min. Le moteur satisfait aux règlements EUROMOT II et EPA 2. Boîte de distribution à cinq pompes hydrauliques à débit variable du type à pistons axiaux ainsi que pompes à engrenages.

### Tambours

L'équipement standard de la partie tournante comprend trois tambours – treuil no 1, treuil no 2 et mécanisme de relevage. Les tambours sont entraînés par des moteurs hydrauliques munis de réducteurs planétaires, sous bain d'huile, en carter étanche. Tous les tambours sont munis de freins à disques multiples, à commande par ressorts, et desserrés hydrauliquement. Freinage anti-usure hydraulique pour descendre la charge. Les pattes de câble H 1, 2, 3 et W 1, 2 sont équipées des attaches à jonction rapide. Treuils H 1 + 2 sont démontables pour diminuer le poids de transport.

### Mécanisme d'orientation

Entraîné par moteur hydraulique avec réducteur planétaire, sous bain d'huile, en carter étanche. Frein d'arrêt à commande par ressorts, desserré hydrauliquement ainsi que freinage anti-usure hydraulique.

### Commande

Pilotage électronique de soupape proportionnel intégré dans un automate programmable avec diagnostic de dysfonctionnement. Régulation automatique assurant l'utilisation optimale de la puissance du moteur.

### Cabine

Cabine confortable avec large pare-brise et climatisation. Vitrage de sécurité, fenêtre de toit, chauffage à air autonome, organes de commande et instruments de contrôle. Cabine inclinable en arrière assurant au grutier une visibilité optimale. Une caméra est installée pour la surveillance des treuils. Pendant le transport, la cabine est basculée à l'avant de la partie tournante.

### Installation électrique

24 V courant continu.

## Equipement optionnel

### Contrepoids

20 t sur la partie tournante (uniquement en combinaison avec lest central).

### Lest central

60 t.

### Système de relevage hydraulique pour chevalet

### Vérins de montage

Quatre vérins hydrauliques sur la partie centrale (repliable sans excéder la largeur de 3 m) permettant le montage facile des chenilles.

### Chariot contrepoids

Entraînement 4 x 4, poids total max. 325 t.

### Connexion rapide

Connexion rapide hydraulique entre châssis et partie tournante permettant le démontage facile pour réduire le poids de transport.

### Patins des chenilles

2000 mm

## Configurations de flèche S et L

SH:	Flèche principale: pied 10,5 m (utilisé à installer treuils W1/H3), intercalaires 12 m et 6 m (type 2724) et tronçon conique 12 m, tête avec jeu de poulies 600 t 1,5 m. Longueurs de flèche principale: 24-84 m.
SH / LH:	Flèche principale: idem SH 60 m, allongée par type 2421 de la fléchette et par l'élément de pointe 7,5 m. Longueurs de flèche principale: 66-102 m.
SW:	Flèche principale: idem SH. Fléchette: pied 4,5 m, intercalaires 12 m et 6 m (type 2421) et élément de pointe 7,5 m. Longueurs de flèche principale: 30-66 m. Longueurs de fléchette: 24-84 m.
SSL:	Flèche principale: idem SH. Mât 30 m, portée 15 m (autres portées sur demande), contrepoids Superlift 0-300 t (par progression de 50 t). Longueurs de flèche principale: 36-84 m.
SSL / LSL:	Flèche principale: idem SH 84 m, allongée par type 2421 de la fléchette et par l'élément de pointe 7,5 m. Mât 30 m, portée 15 m (autres portées sur demande), contrepoids Superlift 0-300 t (par progression de 50 t). Longueurs de flèche principale: 90-138 m.
SWSL: (SFSL)	Flèche principale: idem SH. Fléchette: idem SW. Mât 30 m, portée 15 m (autres portées sur demande), contrepoids Superlift 0-300 t (par progression de 50 t). Longueurs de flèche principale: 36-84 m. Longueurs de fléchette: 24-84 m.
LF:	Flèche principale: idem SH, SH/LH. Fléchette: pied 6 m, intercalaires 12 m (type 1813), élément de pointe 6 m. Longueurs de flèche principale: 30-96 m. Longueurs de fléchette: 12, 24, 36 m.
LFSL:	idem LF, cependant en combinaison avec équipement SL. Longueurs de flèche principale: 30-138 m. Longueurs de fléchette: 12, 24, 36 m.
SFVL:	Flèche principale: idem SH, longueurs 42-84 m, sans jeu de poulies. Fléchette: pied 4,5 m, intercalaire 6 m; tête levages-lourds 1,5 m. Jeu de poulies 600 t idem SH.
Sécurités	Contrôleur d'état de charge électronique, contacteur de fin de course haut, limiteurs de mouvements de la flèche, retenues hydrauliques anti-basculement de la flèche, anémomètre.
Équipement accessoire	
Treuil H3	Tambour supplémentaire sur la flèche principale (à utiliser avec LF ou runner). Effort au brin simple idem H1, longueur de câble 650 m.
Tambour de mouflage	monté sur la partie tournante
Runner	environ 2 m à installer en tête de flèche ou sur l'élément de pointe (pas en combinaison avec LF).



# Transport example for CC 2800

## Transportbeispiel CC 2800

### Exemple de transport pour la CC 2800

Load approx. 81 t  
Ladung ca. 81 t  
Charge environ 81 t

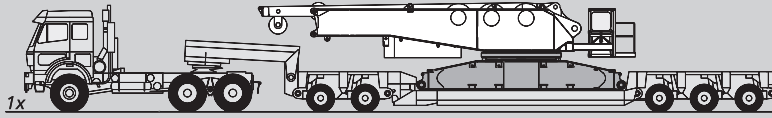

- Superlift counterweight · Superlift-Gegengewicht · Contrepoids Superlift
- Basic crane · Grundgerät · Machine de base
- Boom combination · Auslegerkombination · Combinaison de fleche SWSL 72 + 72 m
- Containers, boxes etc. · Container, Boxen etc. · Conteneurs, boîtes etc.
- Boom combination · Auslegerkombination · Combinaison de fleche LF 36 m
- Low-loader · Tieflader · Semi-remorque

Load approx. 21.1 t  
Ladung ca. 21,1 t  
Charge environ 21,1 t

1x

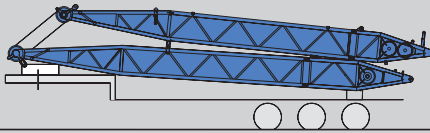

Load approx. 15 t  
Ladung ca. 15 t  
Charge environ 15 t

1x

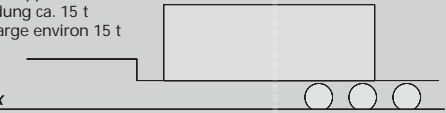

Load 40.3 t  
Ladung 40,3 t  
Charge 40,3 t

2x

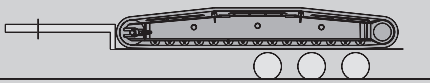

Load 20.8 t  
Ladung 20,8 t  
Charge 20,8 t

2x

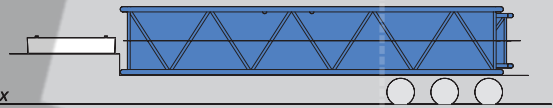

Load 29 t  
Ladung 29 t  
Charge 29 t

1x

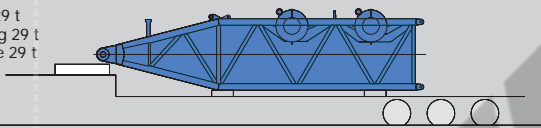

Load 28.4 t  
Ladung 28,4 t  
Charge 28,4 t

1x

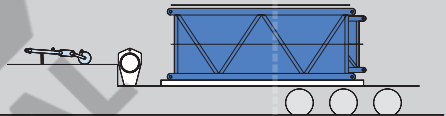

Load 19.5 t  
Ladung 19,5 t  
Charge 19,5 t

1x

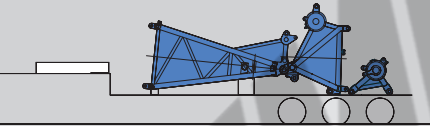

Load 25.7 t  
Ladung 25,7 t  
Charge 25,7 t

1x

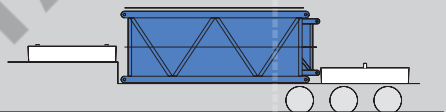

Load 29 t  
Ladung 29 t  
Charge 29 t

1x

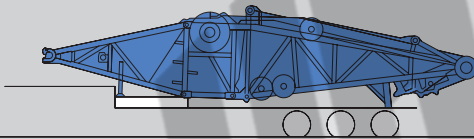

Load 24.9 t  
Ladung 24,9 t  
Charge 24,9 t

1x

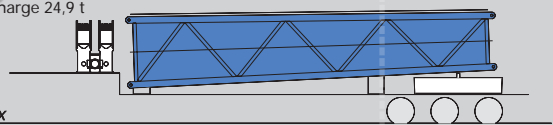

Load 16.1 t  
Ladung 16,1 t  
Charge 16,1 t

1x

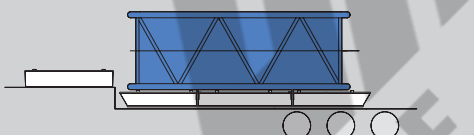

Load 29.9 t  
Ladung 29,9 t  
Charge 29,9 t

1x

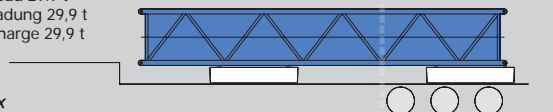

Load 23.7 t  
Ladung 23,7 t  
Charge 23,7 t

1x

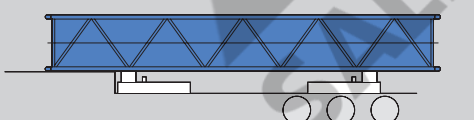

Load 29 t  
Ladung 29 t  
Charge 29 t

2x

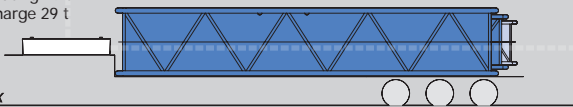

Load 34.3 t  
Ladung 34,3 t  
Charge 34,3 t

1x

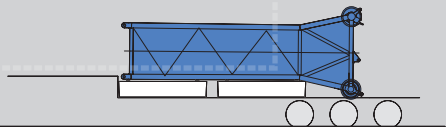

Load 21.8 t  
Ladung 21,8 t  
Charge 21,8 t

1x

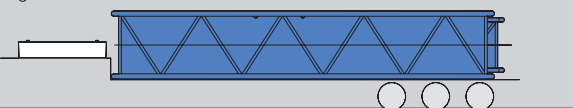

Load 32.8 t  
Ladung 32,8 t  
Charge 32,8 t

1x

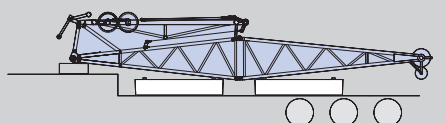

60 t Superlift counterweight can be transported together with the complete SWSL attachment 84 m + 84 m + 36 m LF. Depending on the load case, the remaining 240 t Superlift counterweight and some mats as required, will have to be carried on separate low-loaders.

Mit der gesamten Einrichtung SWSL 84 m + 84 m + 36 m LF lassen sich auch noch 60 t Superlift-Gegengewicht mitnehmen. Je nach Lastfall erfordern die restlichen 240 t Superlift-Gegengewicht sowie einige Unterleg-Matten weitere Tieflader.

60 t de contrepoids Superlift peuvent être transportés avec l'équipement SWSL 84 m + 84 m + 36 m LF tout ensemble. Les 240 t résiduelles du contrepoids Superlift ainsi que quelques plaques de calage, telles que nécessaires en fonction du cas de levage, seront à transporter sur des semi-remorques supplémentaires.

Subject to change without notice! · Änderungen vorbehalten! · Sous réserve de modification!

03/01

MAIN MENU

Inhalt

Contents

Contenu