

DEMAG
Material Handling Equipment

Mobile Cranes

Demag AC 665

UNIK
SALE & RENTAL

Dimensions

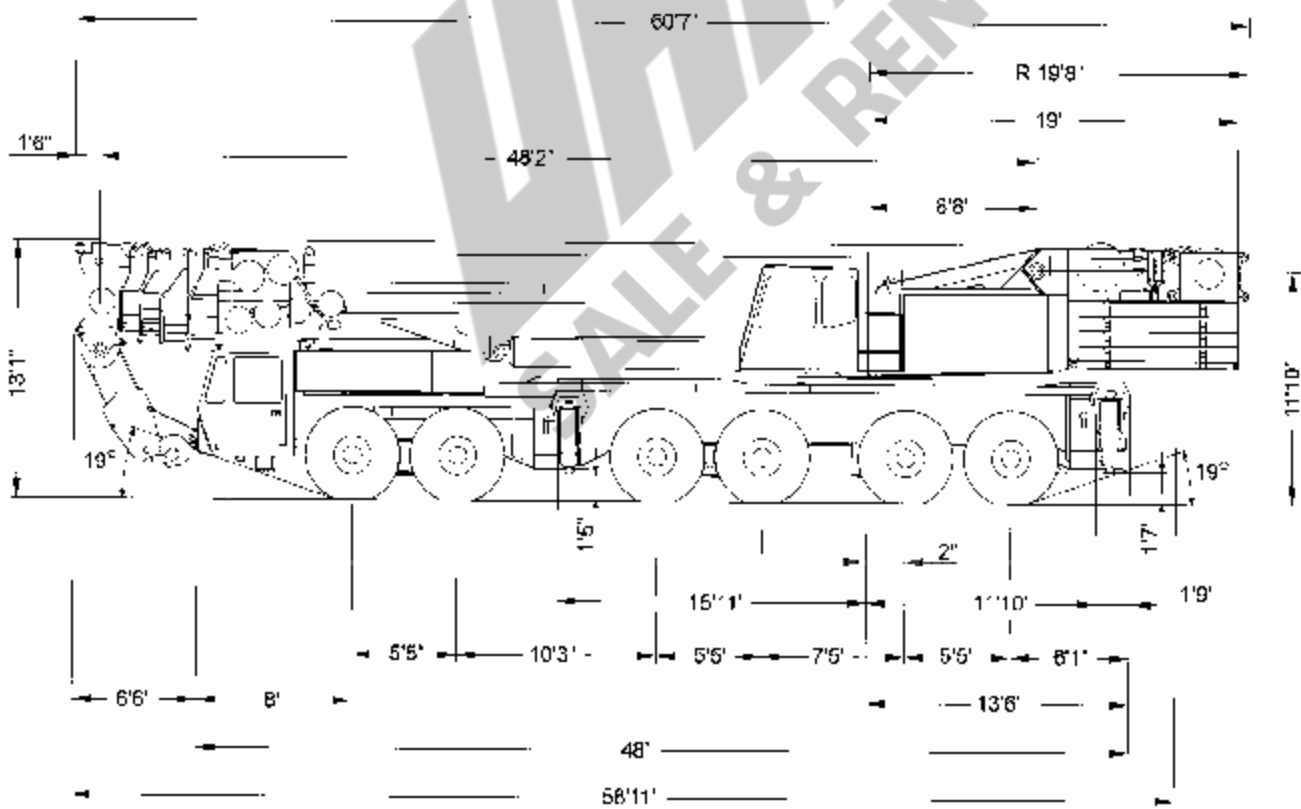

Dimensions

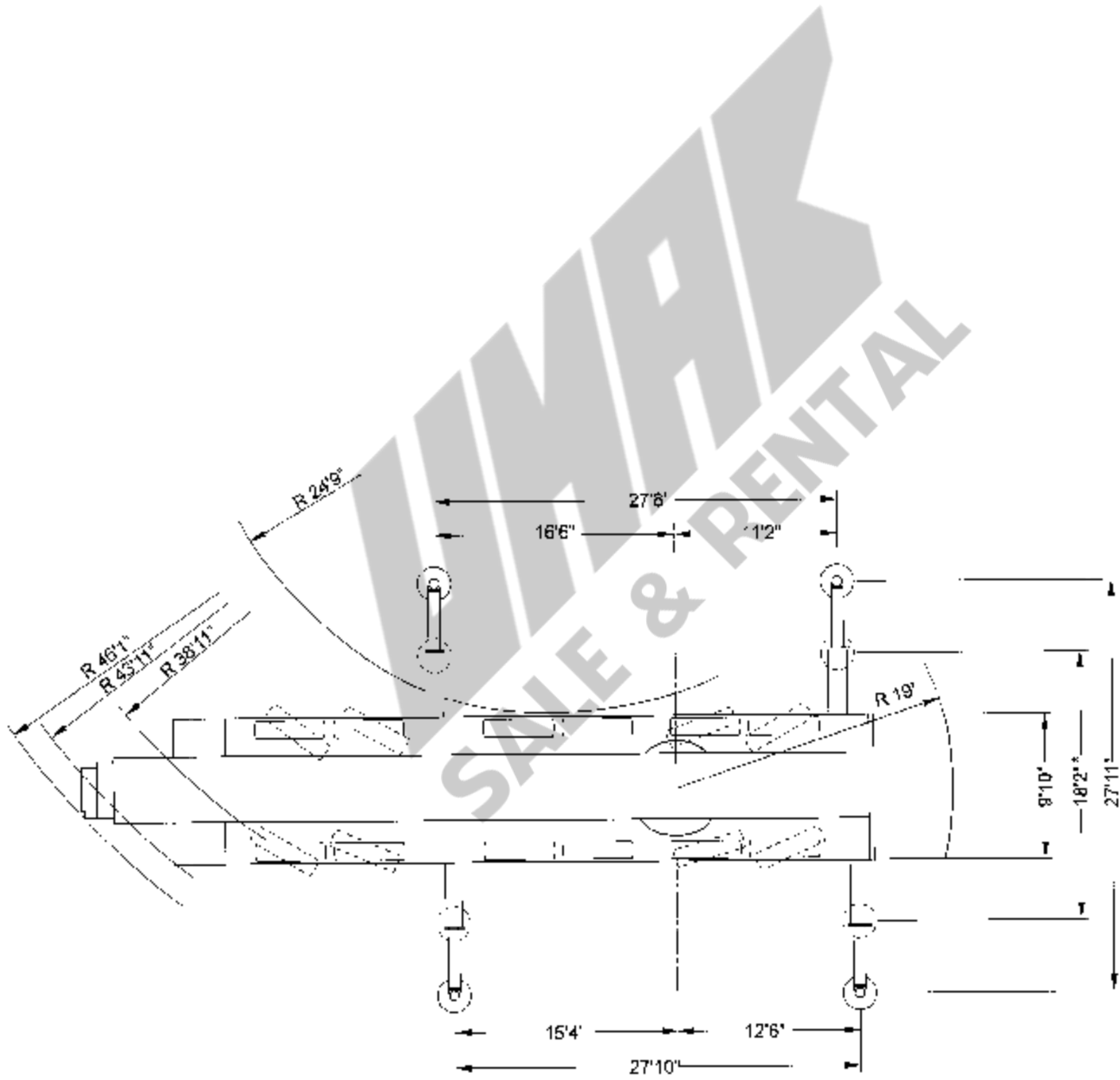

* Duties with reduced outrigger base on request

Dimensions

Hoist II

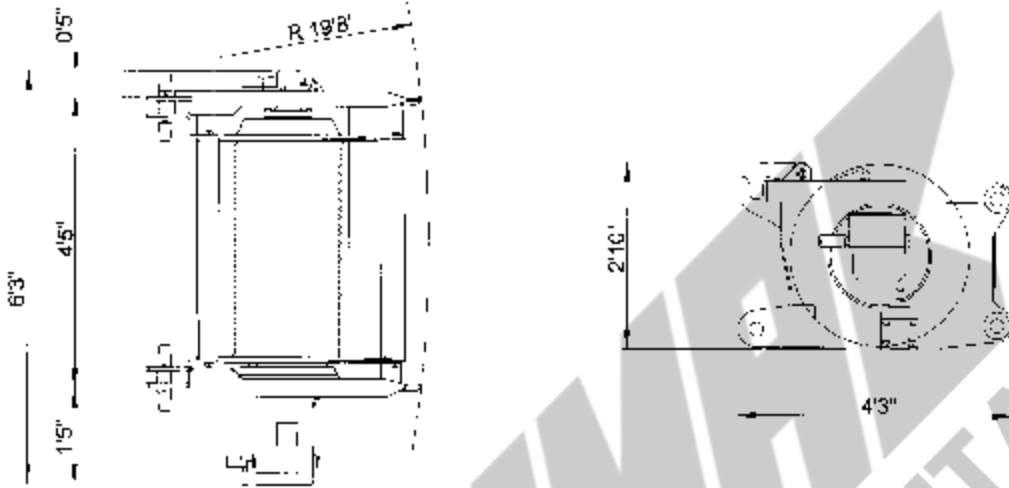

Hoist II with luffing mast bridle and luffing rope bridle

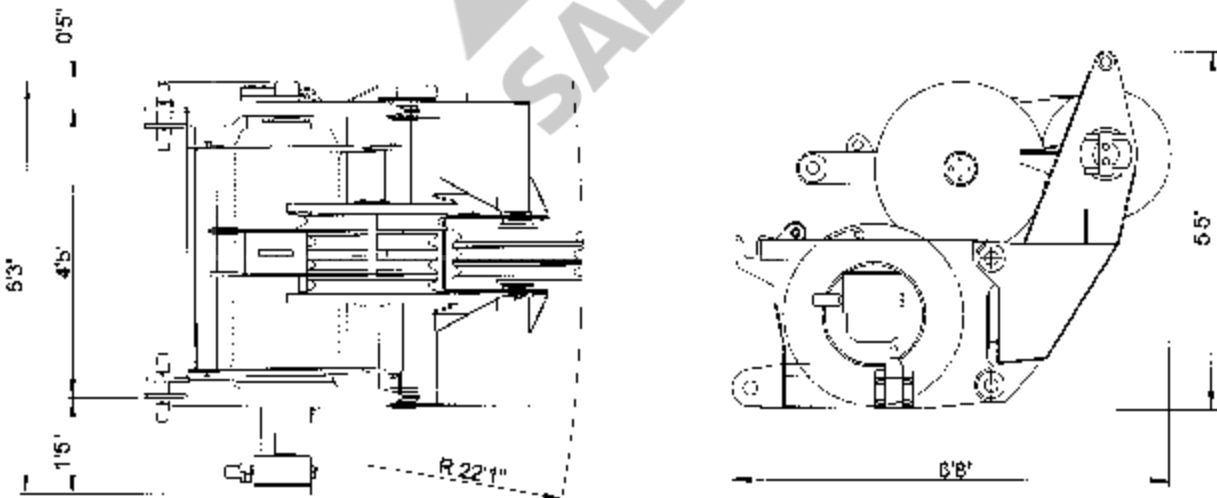

Dimensions

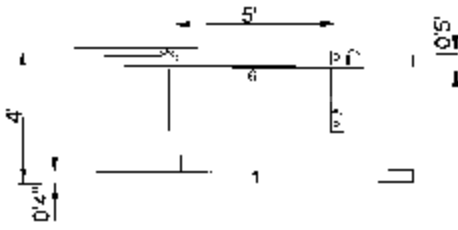

24,300 lb counterweight incl hoist II or equivalent weight for hoist II

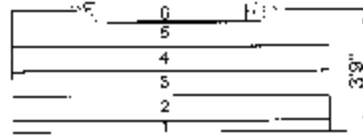

68,400 lb / 118,900 lb counterweight

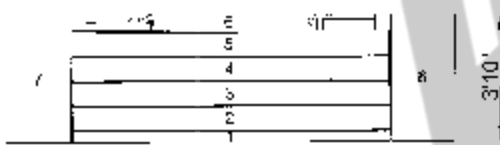
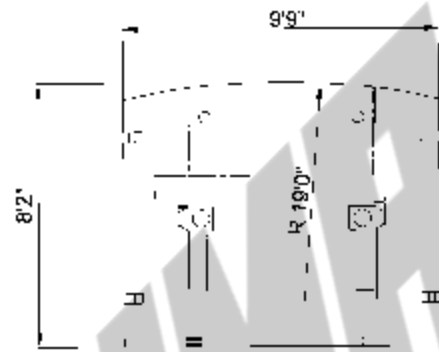

167,600 lb counterweight (optional)

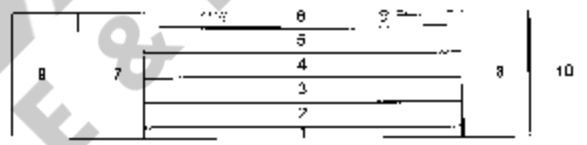

220,600 lb counterweight (optional)

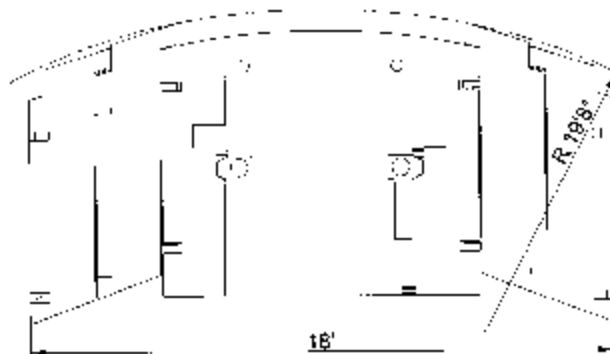
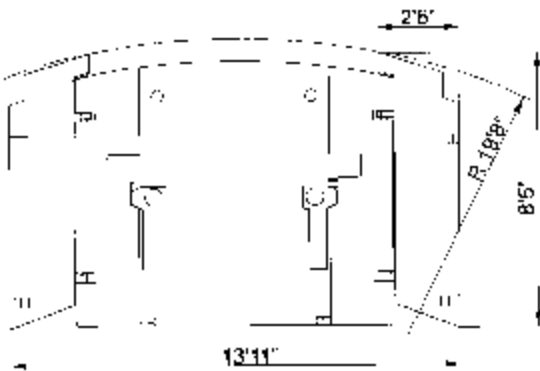

Specifications

Working speeds (infinitely variable)

Mechanisms	Normal speed	High speed	Max. permissible line pull ¹⁾	Length of hoist rope
Hoist I	164 ft/min	433 ft/min	22,500 lb	1.150 ft
Hoist II	164 ft/min	433 ft/min	22,500 lb	1.550 ft
Slewing				max. 1.5 rpm
Telescoping speed				49.0 - 81.0 ft: 55 s 49.0 - 113.0 ft: 110 s 49.0 - 198.8 ft: 330 s
Boom elevation				-1.3° - +82.6°: 86 s

Carrier performance

Travel speed	0..43 mph
Gradeability	65%
Ground clearance	1'5" / 1'7"

Hook block/Single line hook

Type	Possible load ¹⁾	Number of sheaves	Number of lines	Weight	D ²⁾
2 x 180 ^{***}	550,000 lb	2 x 7	2 x 14	8,400 lb	10 ft
250 ^{**}	480,000 lb	11	23	4,400 lb	10 ft
200 [*]	405,000 lb	9	19	3,500 lb	10 ft
160	326,000 lb	7	15	3,100 lb	10 ft
125	245,000 lb	5	11	2,600 lb	10 ft
80	159,000 lb	3	7	2,300 lb	10 ft
40	68,000 lb	1	3	1,600 lb	8 ft
12.5	22,000 lb	Single line hook	1	1,300 lb	7 ft

Remarks

- ¹⁾ varies depending on national regulations
- ²⁾ heavy-lift attachment (2 add. sheaves) required
- ^{*)} heavy-lift attachment (4 add. sheaves) required
- ^{***)} heavy lift attachment (2 add. sheaves) and bridle

Working ranges main boom

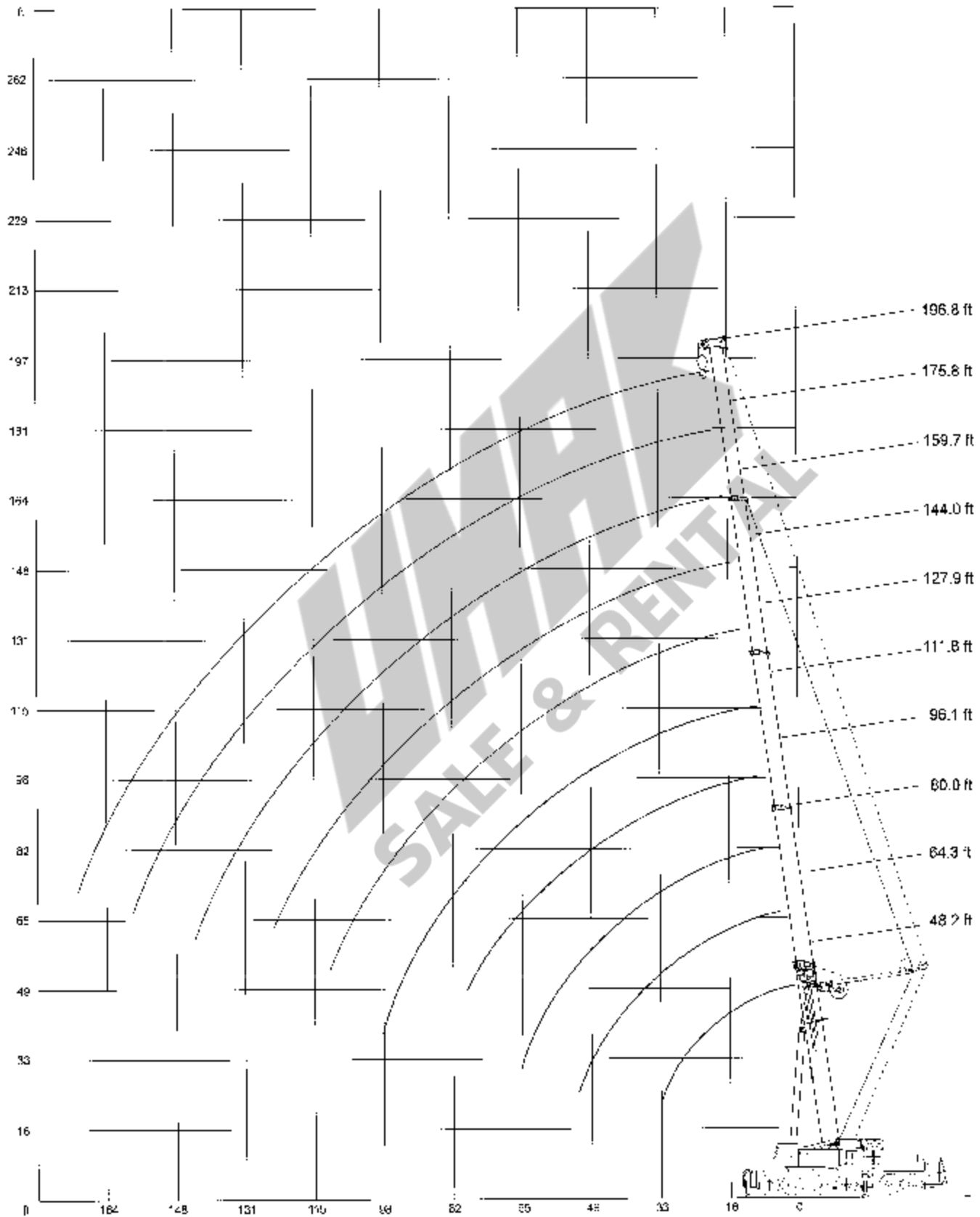

Lifting capacities main boom with Superlift

220,500 lb



 360°

85%

Radius ft	Main boom						
	111.8 ft	127.9 ft	144.0 ft	144.0 ft	159.7 ft	175.8 ft	191.8 ft
	1,000 lb						
16	165.0	-	-	-	-	-	-
19	165.0	132.0	-	-	-	-	-
25	165.0	132.0	121.0	88.0	-	-	-
26	165.0	132.0	121.0	88.0	94.5	-	-
29	165.0	132.0	121.0	88.0	94.5	72.5	-
33	160.0	129.5	113.5	88.0	94.5	72.5	55.1
39	145.0	122.5	113.5	88.0	94.5	72.5	55.1
46	123.0	112.0	106.5	80.0	94.5	72.5	55.1
52	106.0	103.0	99.5	75.0	92.5	72.5	55.1
59	90.5	88.0	89.0	69.0	90.0	72.5	55.1
65	60.0	78.0	79.0	88.0	80.0	72.5	55.1
72	70.5	68.5	69.5	82.0	70.5	68.0	55.1
79	82.5	61.0	81.0	58.5	63.0	64.5	55.1
85	56.5	54.7	55.2	55.9	56.7	56.5	54.4
92	50.2	48.6	48.6	53.0	50.3	52.3	52.3
98	41.6	43.7	44.2	50.2	45.5	47.5	47.9
105	-	39.2	39.4	45.4	41.0	42.7	43.2
111	-	34.8	36.0	41.7	37.3	39.1	39.5
118	-	-	32.2	38.1	33.5	35.3	35.7
124	-	-	29.8	35.5	30.7	32.5	32.7
131	-	-	-	-	27.8	29.8	29.8
138	-	-	-	-	24.9	26.8	27.2
144	-	-	-	-	8.6	24.8	25.0
151	-	-	-	-	-	22.4	22.6
157	-	-	-	-	-	18.6	21.0
164	-	-	-	-	-	-	19.1
170	-	-	-	-	-	-	15.5

Boom extension sequence in %

Tale 1	45	90	90	0	90	90	100
Tale 2	45	45	90	90	90	90	100
Tale 3	45	45	45	90	90	90	100
Tale 4	45	45	45	90	45	90	100

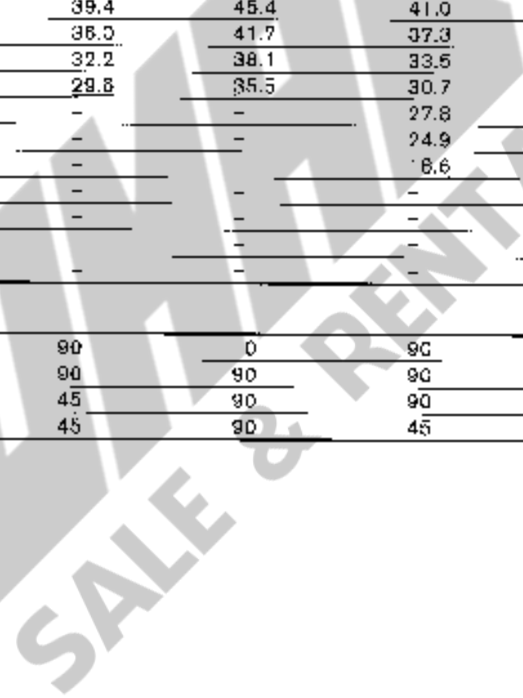

Lifting capacities main boom with Superlift

167,600 lb



360°

85%

Radius ft	Main boom						
	111.8 ft	127.9 ft	144.0 ft	144.0 ft 1,000 lb	159.7 ft	175.9 ft	198.8 ft
18	165.0	-	-	-	-	-	-
19	165.0	132.0	-	-	-	-	-
23	165.0	132.0	121.0	88.0	-	-	-
26	165.0	132.0	121.0	88.0	94.5	-	-
29	165.0	132.0	121.0	88.0	94.5	72.5	-
33	160.0	129.5	118.5	88.0	94.5	72.5	55.1
39	134.5	122.5	113.5	88.0	94.5	72.5	55.1
48	110.0	108.5	103.5	80.0	94.5	72.5	55.1
52	95.5	92.5	94.5	75.0	92.5	72.5	55.1
59	80.5	78.0	79.0	69.0	80.5	72.5	55.1
65	70.0	69.0	69.0	66.0	71.0	71.5	55.1
72	61.5	59.9	60.0	62.0	61.5	63.5	55.1
79	53.7	52.0	52.4	58.4	53.9	55.9	54.9
85	47.9	46.3	46.8	52.9	49.3	50.3	50.4
92	42.4	40.8	41.1	47.0	42.5	44.4	44.8
98	38.4	36.4	37.1	43.0	38.2	40.2	40.4
105	-	32.4	32.6	38.7	39.8	35.9	36.1
111	-	29.1	29.6	36.5	30.7	32.5	32.9
118	-	-	26.2	32.2	27.6	29.3	29.8
124	-	-	23.4	29.8	24.9	26.7	26.9
131	-	-	-	-	21.9	24.1	24.3
138	-	-	-	-	19.1	21.0	21.7
144	-	-	-	-	17.0	19.0	19.3
151	-	-	-	-	-	16.7	16.9
157	-	-	-	-	-	15.1	15.3
164	-	-	-	-	-	-	13.4
170	-	-	-	-	-	-	11.8

Boom extension sequence in %

Tele 1	45	90	90	0	90	90	100
Tele 2	45	45	90	90	90	90	100
Tele 3	45	45	45	90	90	90	100
Tele 4	45	45	45	90	45	90	100

SALE & RENTAL

Lifting capacities main boom

220,500 lb



360°

85%

Radius ft	Main boom												
	48.2 ¹⁾ ft	48.2 ft	64.3 ft	80.0 ft	96.1 ft	111.8 ft	111.8 ft	127.9 ft	144.0 ft	159.7 ft	175.9 ft	196.8 ft	
B	1,000 b												
10	600.0 ²⁾	-	-	-	-	-	-	-	-	-	-	-	-
11	544.0 ²⁾	465.0*	319.0	-	-	-	-	-	-	-	-	-	-
13	434.0*	449.0*	319.0	264.0	-	-	-	-	-	-	-	-	-
15	393.0*	401.0*	319.0	264.0	-	-	-	-	-	-	-	-	-
16	363.0*	364.0*	312.0	264.0	209.0	-	-	-	-	-	-	-	-
19	311.0	308.0	284.0	264.0	209.0	158.5	158.5	-	-	-	-	-	-
23	257.0	257.0	253.0	242.0	193.5	158.5	158.5	132.0	-	-	-	-	-
26	227.0	227.0	222.0	222.0	179.5	154.5	158.5	132.0	121.5	-	-	-	-
29	209.0	209.0	199.0	201.0	165.0	144.0	153.0	132.0	117.5	84.5	-	-	-
33	177.0	177.0	173.0	174.0	150.0	130.5	142.5	122.5	108.5	84.5	72.5	-	-
39	-	-	144.0	145.0	132.0	114.5	129.5	107.5	96.3	86.0	72.5	55.1	-
46	-	-	117.5	118.5	114.0	99.0	116.5	93.5	84.5	77.0	67.0	55.0	-
52	-	-	101.5	102.5	100.0	89.0	106.5	84.5	75.5	69.0	61.5	52.6	-
59	-	-	-	88.0	86.0	78.0	91.5	76.0	68.0	62.0	55.8	48.5	-
65	-	-	-	78.0	75.5	71.0	81.5	70.0	63.0	56.8	51.7	46.1	-
72	-	-	-	-	66.0	64.0	71.5	63.5	57.4	51.9	47.7	41.3	-
79	-	-	-	-	57.8	58.1	64.5	58.2	52.3	47.4	44.2	38.0	-
85	-	-	-	-	-	52.5	58.5	54.0	48.4	44.0	41.7	35.4	-
92	-	-	-	-	-	48.3	52.3	49.7	44.2	40.5	38.9	32.3	-
98	-	-	-	-	-	38.4	45.5	46.2	41.2	37.8	36.7	30.3	-
105	-	-	-	-	-	-	-	41.0	37.9	35.0	34.1	27.9	-
111	-	-	-	-	-	-	-	37.5	35.4	32.8	32.1	26.5	-
113	-	-	-	-	-	-	-	-	32.8	30.4	30.0	24.9	-
124	-	-	-	-	-	-	-	-	31.0	28.4	28.2	23.5	-
131	-	-	-	-	-	-	-	-	-	26.5	26.5	22.3	-
138	-	-	-	-	-	-	-	-	-	24.3	24.5	21.1	-
144	-	-	-	-	-	-	-	-	-	21.1	23.2	20.1	-
151	-	-	-	-	-	-	-	-	-	-	22.0	18.8	-
157	-	-	-	-	-	-	-	-	-	-	20.8	18.1	-
164	-	-	-	-	-	-	-	-	-	-	-	16.9	-
170	-	-	-	-	-	-	-	-	-	-	-	15.9	-

Boom extension sequence in %

Tale	0	0	45	45	90	90	45	90	90	90	90	100
Tale 1	0	0	0	45	90	90	45	90	90	90	90	100
Tale 2	0	0	0	45	45	90	45	45	90	90	90	100
Tale 3	0	0	0	0	0	0	45	45	45	90	90	100
Tale 4	0	0	0	0	0	0	45	45	45	45	80	100

Remarks

- * with heavy duty attachment
- ** with heavy duty attachment, double hook block
- ¹⁾ only over rear
- ²⁾ with heavy duty attachment, double hook block and add. centra outriggers

Lifting capacities main boom

167,600 lb



360°

85%

Radius ft	Main boom											
	48.2 ft	64.3 ft	80.0 ft	96.1 ft	111.8 ft	111.8 ft	127.9 ft	144.0 ft	159.7 ft	175.8 ft	198.8 ft	
	1,000 lb											
10	452.0*	319.0	-	-	-	-	-	-	-	-	-	-
11	428.0*	319.0	264.0	-	-	-	-	-	-	-	-	-
13	386.0*	319.0	264.0	-	-	-	-	-	-	-	-	-
15	350.0*	312.0	264.0	209.0	-	-	-	-	-	-	-	-
16	337.0*	309.0	264.0	209.0	-	-	-	-	-	-	-	-
18	287.0	279.0	264.0	209.0	158.5	158.5	-	-	-	-	-	-
23	235.0	231.0	233.0	193.5	158.5	158.5	132.0	-	-	-	-	-
26	208.0	203.0	205.0	176.5	154.5	158.5	132.0	121.5	-	-	-	-
29	183.5	182.0	183.0	165.0	144.0	159.0	132.0	117.5	94.5	-	-	-
33	160.5	156.5	158.5	150.0	130.5	142.5	122.5	108.5	94.5	72.5	-	-
39	-	129.5	130.5	128.0	114.5	129.5	107.5	96.5	86.0	72.5	55.1	-
46	-	106.5	106.5	105.5	99.0	112.0	99.5	84.5	77.0	67.0	55.0	-
52	-	90.5	90.5	89.5	89.0	97.0	84.5	75.5	69.0	61.5	52.6	-
59	-	-	77.0	75.0	76.0	81.5	76.0	66.0	60.0	55.8	48.5	-
65	-	-	67.0	65.5	66.0	72.5	70.0	63.0	56.9	51.7	45.1	-
72	-	-	-	56.4	57.1	63.0	60.5	57.4	51.9	47.7	41.3	-
79	-	-	-	46.9	49.5	55.5	53.3	52.2	47.4	44.2	38.0	-
85	-	-	-	-	43.9	50.1	47.6	47.8	44.0	41.7	35.4	-
92	-	-	-	-	38.7	44.6	42.2	42.4	40.5	38.9	32.3	-
98	-	-	-	-	34.6	40.4	38.0	38.2	37.8	36.7	30.3	-
105	-	-	-	-	-	-	33.9	34.1	35.0	34.1	27.9	-
111	-	-	-	-	-	-	30.9	30.9	32.2	32.1	26.5	-
118	-	-	-	-	-	-	-	27.6	28.7	30.0	24.9	-
124	-	-	-	-	-	-	-	24.7	26.3	27.6	23.5	-
131	-	-	-	-	-	-	-	-	22.9	24.7	22.0	-
138	-	-	-	-	-	-	-	-	20.2	21.9	21.1	-
144	-	-	-	-	-	-	-	-	18.4	19.9	20.1	-
151	-	-	-	-	-	-	-	-	-	17.6	18.0	-
157	-	-	-	-	-	-	-	-	-	16.2	16.4	-
164	-	-	-	-	-	-	-	-	-	-	14.5	-
172	-	-	-	-	-	-	-	-	-	-	13.1	-

Boom extension sequence in %

Tele 1	0	45	45	90	90	45	90	90	30	90	100
Tele 2	0	0	45	45	90	45	45	90	90	90	100
Tele 3	0	0	0	0	0	45	45	45	90	90	100
Tele 4	0	0	0	0	0	45	45	45	45	90	100

Remarks

- * with heavy duty attachment
- * with heavy duty attachment, double hook block
- ¹⁾ only over rear
- ²⁾ with heavy duty attachment, double hook block and add. central outriggers

Lifting capacities main boom

116,900 lb



360°

85%

Radius ft	Main boom																		
	48.2 ft	54.3 ft	80.0 ft	96.1 ft	96.1 ft	111.8 ft	111.8 ft	111.8 ft	127.9 ft	127.9 ft	144.0 ft	144.0 ft	144.0 ft	154.5 ft	154.5 ft	159.7 ft	175.8 ft	196.8 ft	
	1,000 lb																		
10	437.0*	319.0	-	-	-	-	-	-	-	-	-	-	-	-	-	-	-	-	-
11	414.0*	319.0	264.0	-	-	-	-	-	-	-	-	-	-	-	-	-	-	-	-
13	372.0*	319.0	264.0	-	-	-	-	-	-	-	-	-	-	-	-	-	-	-	-
15	332.0*	311.0	264.0	209.0	134.0	-	-	-	-	-	-	-	-	-	-	-	-	-	-
16	312.0	303.0	264.0	209.0	134.0	-	-	-	-	-	-	-	-	-	-	-	-	-	-
19	262.0	259.0	252.0	209.0	134.0	158.5	158.5	74.5	-	-	-	-	-	-	-	-	-	-	-
23	215.0	211.0	213.0	193.5	134.0	158.5	158.5	74.5	132.0	80.0	-	-	-	-	-	-	-	-	-
26	189.5	185.0	185.0	178.5	134.0	154.5	158.5	74.5	132.0	80.0	12.5	61.5	46.7	-	-	-	-	-	-
29	167.0	164.0	164.0	161.5	125.0	144.0	153.0	74.5	132.0	80.0	117.5	61.5	46.7	64.5	-	-	-	-	-
33	144.0	140.0	142.0	140.0	114.0	130.5	142.5	72.0	122.5	80.0	108.5	61.5	46.7	64.5	72.5	-	-	-	-
39	-	114.0	116.0	114.0	100.0	113.0	120.0	64.0	107.5	73.0	96.5	61.5	46.7	66.0	72.5	55.1	-	-	-
46	-	90.0	90.0	88.0	88.0	90.0	96.5	55.9	93.5	85.5	84.5	58.1	46.7	77.0	87.0	55.0	-	-	-
62	-	78.0	78.0	75.5	80.0	76.0	82.5	50.2	80.0	59.5	75.5	53.3	46.7	69.0	61.5	52.8	-	-	-
69	-	-	66.0	64.0	72.5	85.0	70.5	45.0	68.0	53.1	68.0	48.3	43.4	62.0	55.8	48.5	-	-	-
85	-	-	57.1	64.7	65.5	55.8	62.5	41.5	60.0	48.7	60.5	44.4	40.2	56.9	51.7	45.1	-	-	-
72	-	-	-	44.7	56.6	45.8	52.8	38.4	50.5	44.4	50.8	40.6	36.9	51.9	47.7	41.3	-	-	-
79	-	-	-	36.9	48.6	37.6	45.1	35.8	42.5	40.8	43.1	37.1	33.6	44.7	44.1	38.0	-	-	-
85	-	-	-	-	-	32.0	39.7	33.6	36.6	38.0	37.3	34.7	30.9	39.0	40.9	35.4	-	-	-
92	-	-	-	-	-	26.5	34.0	30.8	31.2	35.4	31.8	32.1	28.3	33.7	35.3	32.9	-	-	-
98	-	-	-	-	-	22.7	30.2	30.4	27.1	33.2	27.6	30.1	26.1	28.9	30.9	30.3	-	-	-
105	-	-	-	-	-	-	-	-	23.1	29.7	23.5	27.9	23.8	24.6	26.6	27.5	-	-	-
111	-	-	-	-	-	-	-	-	20.8	26.7	20.3	26.3	21.9	21.6	23.8	24.3	-	-	-
118	-	-	-	-	-	-	-	-	-	-	17.0	24.7	20.3	18.5	20.5	20.8	-	-	-
124	-	-	-	-	-	-	-	-	-	-	14.9	22.7	18.8	15.9	17.9	18.5	-	-	-
131	-	-	-	-	-	-	-	-	-	-	-	20.3	17.4	13.5	15.3	15.7	-	-	-
138	-	-	-	-	-	-	-	-	-	-	-	-	16.0	11.4	13.1	13.3	-	-	-
144	-	-	-	-	-	-	-	-	-	-	-	-	-	9.5	11.5	11.7	-	-	-
151	-	-	-	-	-	-	-	-	-	-	-	-	-	-	9.4	9.9	-	-	-
157	-	-	-	-	-	-	-	-	-	-	-	-	-	-	6.0	8.2	-	-	-
164	-	-	-	-	-	-	-	-	-	-	-	-	-	-	-	7.0	-	-	-
170	-	-	-	-	-	-	-	-	-	-	-	-	-	-	-	-	-	-	5.8

Boom extension sequence in %

Tele 1	0	45	45	90	0	90	45	0	90	0	90	0	0	90	90	100
Tele 2	0	0	45	45	45	90	45	0	45	90	90	90	100	90	90	100
Tele 3	0	0	0	0	45	0	45	90	45	90	45	90	100	90	90	100
Tele 4	0	0	0	0	45	0	45	90	45	45	45	90	100	45	90	100

Remarks

- * with heavy duty attachment
- Special boom extension sequence

Lifting capacities main boom

68,400 lb



360°

85%

Radius	Main boom															
	48.2 ft	64.3 ft	80.0 ft	96.1 ft	96.1 ft	111.8 ft	111.8 ft	111.8 ft	127.9 ft	127.9 ft	144.0 ft	144.0 ft	154.5 ft	159.7 ft	175.8 ft	188.8 ft
ft	1,000 lb															
10	421.0*	319.0	-	-	-	-	-	-	-	-	-	-	-	-	-	-
11	397.0*	319.0	264.0	-	-	-	-	-	-	-	-	-	-	-	-	-
13	345.0*	319.0	264.0	-	-	-	-	-	-	-	-	-	-	-	-	-
15	299.0	295.0	264.0	209.0	134.0	-	-	-	-	-	-	-	-	-	-	-
16	280.0	278.0	264.0	209.0	134.0	-	-	-	-	-	-	-	-	-	-	-
19	236.0	234.0	233.0	209.0	134.0	158.5	158.5	74.5	-	-	-	-	-	-	-	-
23	183.5	189.0	181.0	189.0	134.0	158.5	158.5	74.5	132.0	80.0	-	-	-	-	-	-
26	165.0	163.0	163.0	161.0	134.0	154.5	158.5	74.5	132.0	80.0	121.5	61.5	46.7	-	-	-
29	144.5	142.0	142.0	140.0	125.0	141.0	147.5	74.5	132.0	80.0	117.5	61.5	46.7	94.5	-	-
33	122.0	120.0	120.0	118.0	114.0	120.0	124.5	72.0	122.5	80.0	106.5	61.5	46.7	94.5	72.5	-
39	-	92.0	98.0	92.0	100.0	92.0	102.5	84.0	100.5	73.0	96.5	61.5	46.7	86.0	72.5	35.1
46	-	70.0	70.0	68.0	81.0	68.0	77.0	55.8	74.5	65.5	74.5	58.1	46.7	77.0	67.0	35.0
52	-	55.2	56.0	53.4	67.0	54.6	63.0	50.2	60.0	59.5	61.0	53.3	46.7	63.0	51.2	32.6
59	-	-	42.4	39.3	53.6	40.6	49.2	45.0	46.6	53.1	47.2	48.3	43.4	49.0	31.2	28.5
65	-	-	33.5	30.4	44.5	31.5	40.5	41.5	37.3	45.1	38.1	44.4	40.2	40.1	42.3	42.5
72	-	-	-	22.4	36.5	23.7	32.1	38.4	29.0	37.0	29.9	38.9	36.9	31.7	34.1	34.5
79	-	-	-	8.5	29.8	17.4	25.8	34.2	22.7	30.4	23.3	32.4	33.0	24.9	27.5	28.0
85	-	-	-	-	19.2	21.9	29.7	18.3	25.8	18.7	27.7	28.4	28.4	20.5	22.7	23.3
92	-	-	-	-	9.1	17.1	25.5	14.2	21.3	14.4	23.0	23.9	18.2	18.4	16.8	-
99	-	-	-	-	6.3	14.1	22.2	11.0	18.2	11.4	20.0	20.7	13.0	15.2	15.6	-
105	-	-	-	-	-	-	-	6.1	14.9	8.1	16.7	17.1	9.9	11.9	12.5	-
111	-	-	-	-	-	-	-	6.1	12.7	6.1	14.5	14.9	7.7	9.6	10.1	-
118	-	-	-	-	-	-	-	-	-	3.7	11.9	12.6	5.0	7.3	7.7	-
124	-	-	-	-	-	-	-	-	-	-	10.1	10.7	3.5	5.4	5.9	-
131	-	-	-	-	-	-	-	-	-	-	8.6	8.8	-	3.5	4.0	-
138	-	-	-	-	-	-	-	-	-	-	-	7.2	-	-	2.3	-

Room extension sequence in %:

Tote	0	45	45	90	0	90	45	0	90	0	80	0	0	90	90	100
Tote 1	0	45	45	90	0	90	45	0	90	0	80	0	0	90	90	100
Tote 2	0	0	45	45	45	90	45	0	45	90	80	90	100	90	90	100
Tote 3	0	0	0	0	45	0	45	90	45	90	45	90	100	90	90	100
Tote 4	0	0	0	0	45	0	45	90	45	45	45	90	100	45	90	100

Remarks

- * with heavy duty attachment
- Special boom extension sequence

SALE & RENT

Lifting capacities main boom

24,300 lb



360°

85%

Radius	Main boom																
	48.2 ft	64.3 ft	80.0 ft	96.1 ft	96.1 ft	111.8 ft	111.8 ft	111.8 ft	127.9 ft	127.9 ft	144.0 ft	144.0 ft	154.5 ft	159.7 ft	175.9 ft	196.8 ft	
#	t,000 lb																
10	368.0*	306.0	-	-	-	-	-	-	-	-	-	-	-	-	-	-	-
11	331.0	306.0	253.0	-	-	-	-	-	-	-	-	-	-	-	-	-	-
13	278.0	273.0	253.0	-	-	-	-	-	-	-	-	-	-	-	-	-	-
15	239.0	240.0	239.0	200.0	134.0	-	-	-	-	-	-	-	-	-	-	-	-
16	225.0	223.0	224.0	200.0	134.0	-	-	-	-	-	-	-	-	-	-	-	-
18	187.0	182.5	185.0	179.5	134.0	154.0	152.5	74.5	-	-	-	-	-	-	-	-	-
23	148.5	140.5	143.0	140.5	134.0	129.5	136.5	74.5	125.5	90.0	-	-	-	-	-	-	-
26	123.0	118.5	120.5	116.5	114.0	117.5	125.5	74.5	111.0	90.0	112.0	81.5	46.7	-	-	-	-
29	99.0	82.5	95.0	92.0	105.0	94.5	103.5	74.5	99.0	80.0	99.0	61.5	46.7	95.0	-	-	-
33	71.0	67.5	69.5	65.0	82.5	67.5	70.5	72.0	78.0	76.5	78.0	61.5	46.7	74.0	69.5	-	-
39	-	44.2	45.7	42.8	58.4	44.4	52.9	62.5	50.7	59.0	51.5	60.0	46.7	52.0	52.2	48.9	-
46	-	27.9	29.2	28.3	40.6	27.9	36.0	45.0	33.4	41.1	34.0	43.3	44.2	34.9	35.8	34.9	-
52	-	19.4	20.5	17.8	30.7	19.2	27.0	35.0	24.3	31.4	24.7	33.4	34.1	25.4	26.7	25.8	-
59	-	-	12.8	3.6	22.7	1.0	18.0	26.7	16.5	23.2	18.8	25.1	25.8	17.4	18.8	18.3	-
65	-	-	7.5	4.2	17.9	5.8	14.1	21.6	11.5	18.1	11.7	19.9	20.8	12.8	13.9	13.7	-
72	-	-	-	-	13.3	-	9.5	17.0	6.3	13.7	7.1	15.9	16.2	8.0	9.3	9.3	-
79	-	-	-	-	8.7	-	5.8	13.3	2.2	10.0	3.1	11.8	12.4	4.7	5.8	5.8	-
85	-	-	-	-	-	-	2.7	11.1	-	7.4	-	9.3	9.8	-	3.6	3.6	-
92	-	-	-	-	-	-	-	8.7	-	4.3	-	6.3	7.2	-	-	-	-
98	-	-	-	-	-	-	-	6.5	-	2.5	-	4.3	5.2	-	-	-	-
106	-	-	-	-	-	-	-	-	-	-	-	2.4	3.0	-	-	-	-

Boom extension sequence in %:

Tele	1	2	3	4	5	6	7	8	9	10	11	12	13	14	15	16	17
Tele 1	0	45	45	90	0	90	45	0	90	0	90	0	0	90	90	100	
Tele 2	0	0	45	45	45	90	45	0	45	90	90	90	100	90	90	100	
Tele 3	0	0	0	0	45	0	45	90	45	90	45	90	100	90	90	100	
Tele 4	0	0	0	0	45	0	45	90	45	45	45	90	100	45	90	100	

Remarks

- * with heavy duty attachment
- Special boom extension sequence

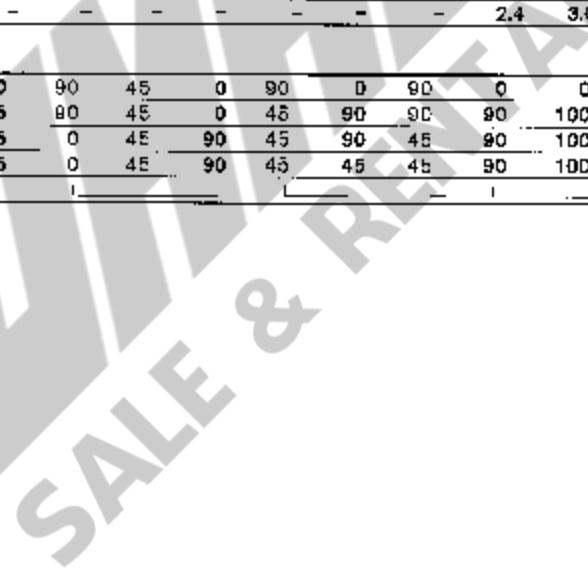

Lifting capacities main boom

0 lb   360° 85%

Radius	Main boom								
	48.2 ft	64.3 ft	80.0 ft	96.1 ft	96.1 ft	111.8 ft	127.9 ft	144.0 ft	154.5 ft
ft	1,000 lb								
10	282.0	254.0	-	-	-	-	-	-	-
11	258.0	249.0	211.0	-	-	-	-	-	-
13	222.0	218.0	211.0	-	-	-	-	-	-
15	192.0	188.5	190.5	107.5	134.0	-	-	-	-
18	179.0	176.0	177.0	187.5	134.0	-	-	-	-
19	149.5	145.5	140.5	136.0	134.0	74.5	-	-	-
23	113.0	107.5	102.0	92.0	125.0	74.5	80.0	-	-
26	79.5	74.0	76.0	68.0	95.0	74.5	80.0	61.5	46.7
29	58.1	52.4	54.6	50.8	70.0	73.0	68.0	61.5	46.7
33	39.0	34.5	36.3	33.4	49.7	55.2	50.1	50.6	46.3
39	-	19.8	21.2	18.7	32.7	37.4	33.4	34.3	33.6
45	-	9.4	10.7	7.8	21.0	25.2	21.7	22.6	22.6
52	-	3.3	4.2	-	15.0	18.8	15.3	16.3	16.3
59	-	-	-	-	9.9	13.4	9.9	11.0	11.0
65	-	-	-	-	6.3	10.0	8.5	7.8	7.8
72	-	-	-	-	2.9	6.9	3.3	4.7	4.9
79	-	-	-	-	-	4.3	-	2.3	2.5
85	-	-	-	-	-	2.3	-	-	-

Boom extension sequence in %									
Te.e 1	0	45	45	90	0	0	0	0	0
Te.e 2	0	0	45	45	45	0	90	90	100
Te.e 3	0	0	0	0	45	90	90	90	100
Te.e 4	0	0	0	0	45	90	45	90	100

Remarks
 Special boom extension sequence

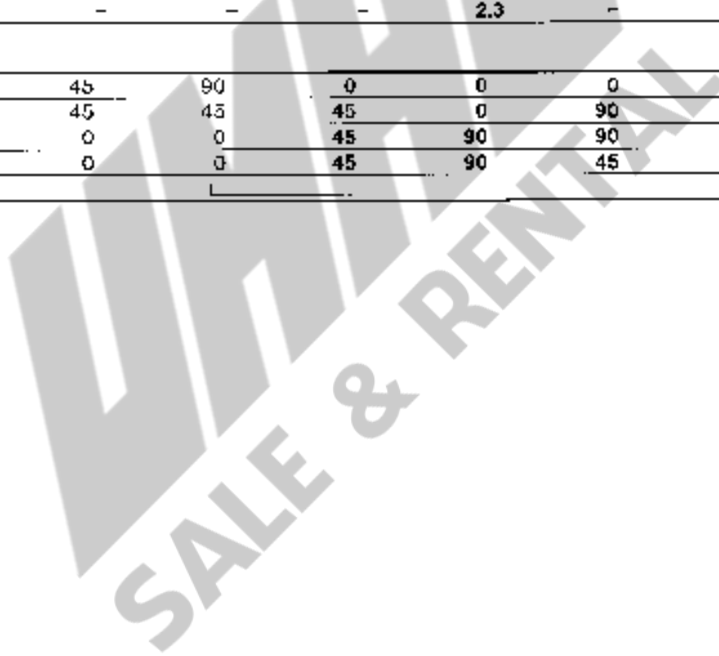

Lifting capacities main boom

24,300 lb



270°

85%

Radius	Main boom															
	48.2 ft	64.3 ft	80.0 ft	96.1 ft	111.6 ft	117.8 ft	111.8 ft	127.9 ft	127.9 ft	144.0 ft	144.0 ft	154.5 ft	159.7 ft	176.8 ft	196.8 ft	
ft	1,000 lb															
10	268.0	305.0	-	-	-	-	-	-	-	-	-	-	-	-	-	-
11	331.0	306.0	253.0	-	-	-	-	-	-	-	-	-	-	-	-	-
19	276.0	273.0	253.0	-	-	-	-	-	-	-	-	-	-	-	-	-
15	241.0	240.0	240.0	200.0	134.0	-	-	-	-	-	-	-	-	-	-	-
16	226.0	223.0	224.0	200.0	134.0	-	-	-	-	-	-	-	-	-	-	-
19	187.0	182.5	185.0	179.5	134.0	154.0	152.5	74.5	-	-	-	-	-	-	-	-
23	148.5	140.5	143.0	140.5	134.0	129.5	136.5	74.5	25.5	80.0	-	-	-	-	-	-
26	124.0	118.5	120.5	116.5	134.0	117.5	128.5	74.5	11.0	80.0	121.5	81.5	46.7	-	-	-
29	99.0	93.5	95.5	93.0	109.5	95.5	109.5	74.5	99.0	80.0	100.5	61.5	46.7	95.0	-	-
33	76.0	70.5	73.0	69.5	86.0	72.0	80.5	72.0	76.0	79.5	76.0	61.5	46.7	74.0	70.0	-
39	-	48.5	50.1	47.4	61.5	48.8	57.6	64.0	54.4	62.0	55.3	61.5	46.7	57.0	57.2	46.6
46	-	32.3	33.6	30.9	44.2	32.3	40.0	48.6	37.5	44.6	38.0	46.6	46.6	39.8	41.1	40.0
52	-	23.6	24.6	22.1	34.5	23.2	30.7	38.5	28.3	34.9	28.7	36.9	37.5	30.5	31.4	30.9
59	-	-	7.0	14.3	26.3	15.4	22.7	30.0	20.3	26.7	20.7	28.5	28.9	22.1	23.2	22.7
65	-	-	1.9	8.7	21.0	13.0	17.7	24.7	15.2	21.4	15.7	23.2	23.6	16.8	17.9	17.7
72	-	-	-	3.6	16.4	4.9	13.1	19.9	10.0	16.8	10.9	18.4	18.8	11.8	13.3	13.1
79	-	-	-	-	12.8	-	9.1	16.2	5.8	13.1	6.7	14.6	15.1	8.0	9.3	9.3
85	-	-	-	-	-	-	6.1	13.5	3.0	10.2	3.3	12.0	12.6	5.4	6.9	6.9
92	-	-	-	-	-	-	3.4	10.9	-	7.4	-	9.4	9.8	2.9	4.1	4.1
98	-	-	-	-	-	-	-	9.3	-	5.4	-	7.2	7.6	-	-	-
105	-	-	-	-	-	-	-	-	-	3.3	-	5.0	5.5	-	-	-
111	-	-	-	-	-	-	-	-	-	1.6	-	3.4	3.8	-	-	-
118	-	-	-	-	-	-	-	-	-	-	-	1.7	2.2	-	-	-

Boom extension sequence in %

Tele 1	0	40	46	90	0	80	45	0	90	0	90	0	0	90	90	100
Tele 2	0	0	45	45	45	80	45	0	45	90	90	90	100	90	90	100
Tele 3	0	0	0	0	45	0	45	90	45	90	45	90	100	90	90	100
Tele 4	0	0	0	0	45	0	45	90	45	45	45	90	100	45	90	100

Remarks

1) Capacities only valid with hoist II fitted or spare weight

Special boom extension sequence



Lifting capacities main boom

24,300 lb



270°

85%

Radius	Main boom															
	48.2 ft	64.3 ft	80.0 ft	96.1 ft	111.6 ft	127.8 ft	143.8 ft	159.9 ft	176.0 ft	192.1 ft	208.2 ft	224.3 ft	240.4 ft	256.5 ft	272.6 ft	288.7 ft
ft	1,000 lb															
10	368.0	305.0	-	-	-	-	-	-	-	-	-	-	-	-	-	-
11	331.0	306.0	253.0	-	-	-	-	-	-	-	-	-	-	-	-	-
13	276.0	273.0	253.0	-	-	-	-	-	-	-	-	-	-	-	-	-
15	241.0	240.0	240.0	200.0	134.0	-	-	-	-	-	-	-	-	-	-	-
16	226.0	223.0	224.0	200.0	134.0	-	-	-	-	-	-	-	-	-	-	-
19	187.0	182.5	185.0	179.5	134.0	154.0	152.5	74.5	-	-	-	-	-	-	-	-
23	148.5	140.5	143.0	140.5	134.0	129.5	136.5	74.5	25.5	80.0	-	-	-	-	-	-
26	124.0	118.5	120.5	118.5	134.0	117.5	128.5	74.5	11.0	80.0	121.5	81.5	46.7	-	-	-
29	99.0	93.5	95.5	93.0	109.5	95.5	109.5	74.5	99.0	80.0	100.5	81.5	46.7	95.0	-	-
33	76.0	70.5	73.0	69.5	86.0	72.0	80.5	72.0	76.0	79.5	76.0	61.5	46.7	74.0	70.0	-
39	-	48.5	50.1	47.4	61.5	48.8	57.8	64.0	54.4	62.0	55.3	61.5	46.7	57.0	57.2	46.6
46	-	32.3	33.6	30.9	44.2	32.3	40.3	48.6	37.5	44.6	38.0	46.6	46.6	39.8	41.1	40.0
52	-	23.6	24.6	22.1	34.5	23.2	30.7	38.5	28.3	34.9	28.7	36.9	37.5	30.5	31.4	30.9
59	-	-	7.0	14.3	26.3	15.4	22.7	30.0	20.3	26.7	20.7	28.5	28.9	22.1	23.2	22.7
65	-	-	1.9	8.7	21.0	10.0	17.7	24.7	15.2	21.4	15.7	23.2	23.6	16.8	17.9	17.7
72	-	-	-	3.6	16.4	4.9	13.1	19.9	10.0	16.8	10.9	18.4	18.8	11.8	13.3	13.1
79	-	-	-	-	12.8	-	9.1	16.2	5.8	13.1	6.7	14.6	15.1	8.0	9.3	9.3
85	-	-	-	-	-	-	6.1	13.5	3.0	10.2	3.3	12.0	12.6	5.4	6.9	6.9
92	-	-	-	-	-	-	3.4	10.9	-	7.4	-	9.4	9.8	2.9	4.1	4.1
98	-	-	-	-	-	-	-	9.3	-	5.4	-	7.2	7.6	-	-	-
105	-	-	-	-	-	-	-	-	-	3.3	-	5.0	5.5	-	-	-
111	-	-	-	-	-	-	-	-	-	1.6	-	3.4	3.8	-	-	-
118	-	-	-	-	-	-	-	-	-	-	-	1.7	2.2	-	-	-

Boom extension sequence in %

Tele	0	40	45	90	0	80	45	0	90	0	90	0	0	90	90	100
Tele 1	0	40	45	90	0	80	45	0	90	0	90	0	0	90	90	100
Tele 2	0	0	45	45	45	80	45	0	45	90	90	90	100	90	90	100
Tele 3	0	0	0	0	45	0	45	90	45	90	45	90	100	90	90	100
Tele 4	0	0	0	0	45	0	45	90	45	45	45	90	100	45	90	100

Remarks

1) Capacities only valid with hoist II fitted or spare weight

Special boom extension sequence



Lifting capacities main boom

0 lb



270⁰⁰

85%

Radius	Main boom								
	48.2 ft	64.3 ft	80.0 ft	96.1 ft	96.1 ft	111.8 ft	127.9 ft	144.0 ft	154.5 ft
ft	1,000 lb								
10	989.0	254.0	-	-	-	-	-	-	-
11	258.0	249.0	211.0	-	-	-	-	-	-
13	222.0	216.0	211.0	-	-	-	-	-	-
15	192.0	188.5	190.5	167.5	134.0	-	-	-	-
16	179.0	176.0	177.0	167.5	134.0	-	-	-	-
19	149.5	145.5	140.5	136.0	134.0	74.5	-	-	-
23	112.0	107.5	102.0	92.0	125.0	74.5	80.0	-	-
26	83.5	77.0	79.0	72.0	95.0	74.5	80.0	61.5	46.7
29	64.0	58.8	60.5	57.2	74.0	74.5	72.0	61.5	46.7
33	45.9	41.6	43.1	40.5	55.2	60.0	58.1	58.0	46.5
39	-	26.5	27.8	25.4	38.3	42.5	38.9	40.9	40.2
46	-	15.8	16.6	14.4	26.1	30.1	26.6	26.5	28.8
62	-	9.5	10.2	7.6	19.7	23.2	20.1	21.7	21.9
69	-	-	-	-	13.9	17.4	14.3	16.1	16.1
85	-	-	-	-	10.4	13.8	10.9	12.3	12.5
72	-	-	-	-	6.9	10.4	7.3	8.9	8.9
79	-	-	-	-	4.0	7.8	4.3	6.0	6.3
85	-	-	-	-	-	5.6	2.3	4.0	4.5
92	-	-	-	-	-	3.7	-	-	2.3
98	-	-	-	-	-	2.3	-	-	-

Boom extension sequence in %

Tele 1	0	45	45	90	0	0	0	0	0
Tele 2	0	0	45	45	45	0	90	90	100
Tele 3	0	0	0	0	45	90	90	90	100
Tele 4	0	0	0	0	45	90	45	90	100

Remarks

- Capacities only valid with hoist fitted or spare weight
- Special boom extension sequence

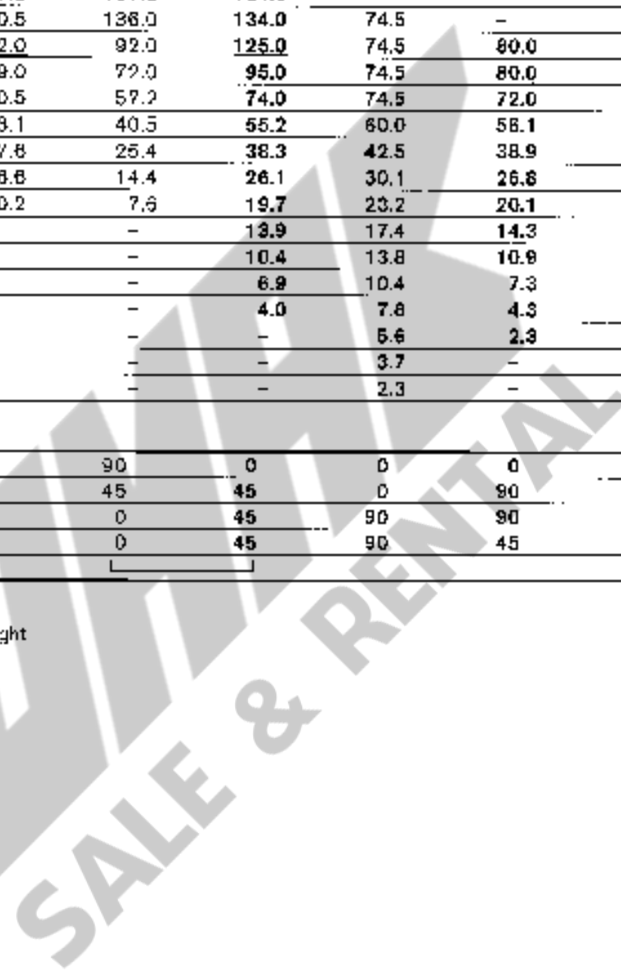

Notes to lifting capacity

Lifting capacities do not exceed 75%/85% of tying load.

Weight of hook blocks and slings are part of the load, and are to be deducted from the capacity ratings.

Crane operation is permissible up to a
wind speed of 32 ft/s

Consult operation manual for further details on wind speed.

All capacities above the parting line are based on structural strength. Capacities below the parting line are based on machine stability.

Crane operation subject to computer charts, only!

For crane operation consult operation manual first!



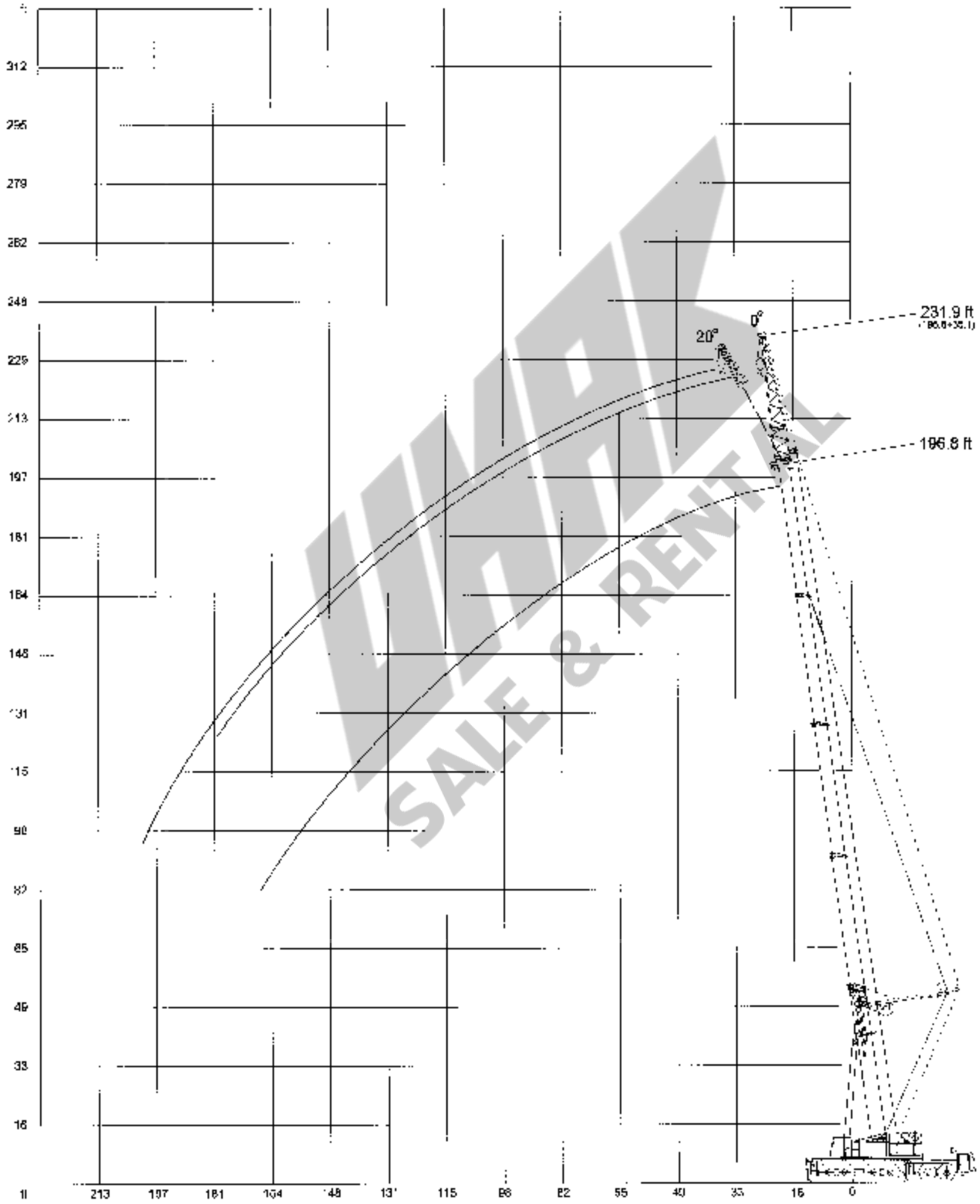

WMAK
SALE & RENTAL

Working ranges main boom extension



Lifting capacities main boom extension with Superlift

Main boom: 196.8 ft

220,500 lb 		 360° 85%		167,600 lb 		 360° 85%	
Radius	Extension	Radius	Extension	Radius	Extension	Radius	Extension
ft	35.1 ft	ft	35.1 ft	ft	35.1 ft	ft	35.1 ft
	1,000 lb		1,000 lb		1,000 lb		1,000 lb
39	33.0	39	33.0	39	33.0	39	33.0
46	33.0	46	33.0	46	33.0	46	33.0
52	31.8	52	31.8	52	31.8	52	31.8
59	30.4	59	30.4	59	30.4	59	30.4
65	29.2	65	29.2	65	29.2	65	29.2
72	28.0	72	28.0	72	28.0	72	28.0
79	26.8	79	26.8	79	26.8	79	26.8
85	26.0	85	26.0	85	26.0	85	26.0
92	25.1	92	25.1	92	25.1	92	25.1
98	24.3	98	24.3	98	24.3	98	24.3
105	23.3	105	23.3	105	23.3	105	23.3
111	22.7	111	22.7	111	22.7	111	22.7
118	21.8	118	21.8	118	21.8	118	21.8
124	21.2	124	21.2	124	21.2	124	21.2
131	20.5	131	20.5	131	20.5	131	20.5
138	19.8	138	19.8	138	19.8	138	19.8
144	19.4	144	19.4	144	19.4	144	19.4
151	18.7	151	18.7	151	18.7	151	18.7
157	18.0	157	18.0	157	16.9	157	16.9
164	17.8	164	17.8	164	15.0	164	15.0
170	17.4	170	17.4	170	13.3	170	13.3
177	16.8	177	16.8	177	11.7	177	11.7
184	16.0	184	16.0	184	10.5	184	10.5
190	14.8	190	14.8	190	9.3	190	9.3
197	12.7	197	12.7	197	7.6	197	7.6
203	9.0	203	9.0	203	6.9	203	6.9

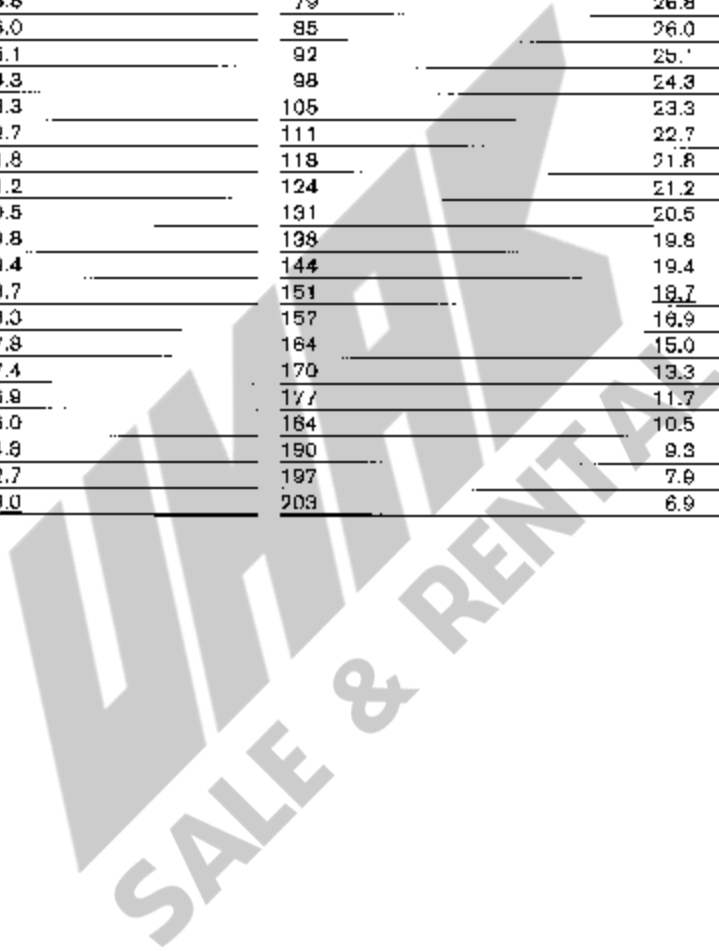

Lifting capacities main boom extension

Main boom: 196.8 ft

116,900 lb   **360°** **85%**

Radius ft	Extension	
	35.1 ft	35.1 ft
	0°	20°
	1,000 lb	
39	31.5	-
46	31.5	-
52	31.5	26.7
59	30.4	26.2
65	28.8	25.6
72	26.9	24.7
79	25.2	23.7
85	23.8	22.9
92	22.2	21.8
98	21.0	21.0
105	19.8	20.0
111	19.0	19.0
118	18.0	18.3
124	17.2	17.5
131	16.5	16.5
139	14.7	15.8
144	12.6	14.2
151	11.0	12.1
157	9.5	10.4
164	7.9	8.8
177	5.5	6.2
190	3.3	3.8

68,400 lb   **360°** **85%**



Radius ft	Extension	
	35.1 ft	35.1 ft
	0°	20°
	1,000 lb	
39	31.5	-
46	31.5	-
52	31.5	26.7
59	30.4	26.2
65	28.8	25.6
72	26.9	24.7
79	25.2	23.7
85	23.8	22.9
92	20.2	21.7
98	17.1	19.5
105	13.8	16.0
111	11.6	13.6
118	9.0	10.8
124	7.2	8.8
131	5.3	6.8
138	3.7	5.0
144	-	3.8
151	-	-
157	-	-
164	-	-
177	-	-
190	-	-

24,300 lb   **360°** **85%**

Radius ft	Extension	
	35.1 ft	35.1 ft
	0°	20°
	1,000 lb	
39	31.5	-
46	31.4	-
52	27.2	26.8
59	19.9	23.1
65	15.0	17.9
72	10.6	12.9
79	7.3	8.3
85	4.7	6.2
92	2.3	4.1

Lifting capacities fixed fly jib with Superlift

Main boom: 175.8 ft¹⁾

220,500 lb  360° 85%							167,600 lb  360° 85%						
Radius	Fly jib						Radius	Fly jib					
	65.6 ft		105.0 ft		134.5 ft			65.6 ft		105.0 ft		134.6 ft	
	3°	20°	3°	20°	3°	20°		3°	20°	3°	20°	3°	20°
ft	1,000 lb						ft	1,000 lb					
59	21.3	-	-	-	-	-	59	21.3	-	-	-	-	-
65	21.1	-	13.2	-	-	-	65	21.1	-	13.2	-	-	-
72	20.7	19.1	13.2	-	8.3	-	72	20.7	19.1	13.2	-	8.3	-
79	20.4	18.9	12.9	-	8.1	-	79	20.4	18.9	12.9	-	8.1	-
85	20.0	18.7	12.7	-	8.1	-	85	20.0	18.7	12.7	-	8.1	-
92	19.6	18.2	12.7	-	7.9	-	92	19.6	18.2	12.7	-	7.9	-
98	19.2	18.0	12.5	9.9	7.9	-	98	19.2	18.0	12.5	9.9	7.9	-
105	18.7	17.6	12.3	9.9	7.7	-	105	18.7	17.6	12.3	9.9	7.7	-
111	18.3	17.2	12.1	9.9	7.5	6.1	111	18.3	17.2	12.1	9.9	7.5	6.1
118	17.8	16.7	11.9	9.7	7.4	6.1	118	17.8	16.7	11.9	9.7	7.4	6.1
124	17.4	16.3	11.7	9.7	7.2	5.9	124	17.4	16.3	11.7	9.7	7.2	5.9
131	16.9	15.8	11.4	9.4	7.2	5.9	131	16.9	15.8	11.4	9.4	7.2	5.9
138	16.3	15.1	11.2	9.2	7.0	5.7	138	16.3	15.1	11.2	9.2	7.0	5.7
144	15.8	14.7	11.0	9.2	6.8	5.7	144	15.8	14.7	11.0	9.2	6.8	5.7
151	15.4	14.3	10.8	9.0	6.8	5.5	151	15.4	14.3	10.8	9.0	6.8	5.5
157	15.0	13.9	10.8	8.8	6.6	5.5	157	15.0	13.9	10.8	8.8	6.6	5.5
164	14.7	13.6	10.5	8.8	6.6	5.2	164	14.4	13.6	10.5	8.8	6.6	5.2
170	14.3	13.2	10.3	8.6	6.4	5.0	170	11.8	13.2	10.3	8.6	6.4	5.0
177	13.9	12.7	10.1	8.3	6.1	5.0	177	9.9	11.5	10.1	8.3	6.1	5.0
184	13.4	12.5	9.9	8.1	6.1	4.8	184	8.5	9.6	8.8	8.1	6.1	4.8
190	12.8	12.3	9.7	7.9	6.3	4.8	190	7.3	8.2	8.8	7.9	5.9	4.8
197	11.4	11.8	9.4	7.9	5.9	4.8	197	5.7	6.8	7.4	7.9	5.9	4.8
203	10.2	10.8	9.2	7.7	5.7	4.6	203	4.9	5.5	6.2	7.7	5.7	4.6
210	9.2	9.4	9.0	7.4	5.5	4.4	210	3.5	4.1	5.2	7.2	5.5	4.4
216	8.0	8.5	8.8	7.2	5.5	4.4	216	2.5	3.1	4.2	5.8	4.5	4.4
223	5.3	7.0	8.6	7.0	5.2	4.1	223	-	3.3	4.8	3.5	4.1	-
229	-	-	7.6	6.8	5.3	4.1	229	-	-	2.9	3.8	2.5	4.1
243	-	-	5.6	6.3	4.9	3.7	243	-	-	-	-	-	2.6
256	-	-	2.4	4.8	4.3	3.5	256	-	-	-	-	-	-
269	-	-	-	-	2.4	3.9	269	-	-	-	-	-	-
282	-	-	-	-	-	2.2	282	-	-	-	-	-	-

Remarks

¹⁾ plus 9.8 ft adapter

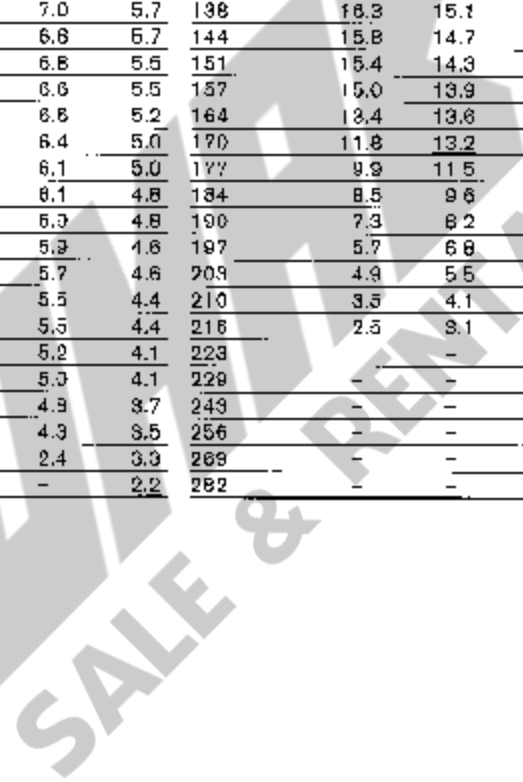

Lifting capacities fixed fly jib

Main boom: 175.8 ft¹⁾

116,900 lb   360° 85%

Radius	Fly jib					
	65.6 ft		106.0 ft		134.5 ft	
	3°	20°	3°	20°	3°	20°
ft	1,000 lb					
59	21.9	-	-	-	-	-
65	20.3	-	14.5	-	-	-
72	19.2	16.3	14.1	-	8.8	-
79	18.2	15.6	13.6	-	8.8	-
85	17.2	15.0	13.2	-	8.6	-
92	16.2	14.3	12.5	-	8.3	-
98	15.4	13.7	12.1	10.4	8.1	-
105	14.5	12.7	11.6	9.6	7.7	-
111	13.7	12.3	11.2	9.2	7.5	6.8
118	12.8	11.6	10.5	8.8	7.2	6.4
124	12.1	11.0	10.1	8.4	6.8	6.1
131	11.4	10.3	9.7	7.9	6.6	5.9
138	10.6	9.6	9.0	7.4	6.1	5.5
144	9.9	9.2	8.6	7.2	5.9	5.3
151	9.1	8.5	8.1	6.8	5.7	5.0
157	8.7	7.9	7.5	6.4	5.3	4.8
164	5.0	6.8	6.6	5.9	5.0	4.4
170	3.8	5.4	5.4	5.5	4.6	4.2
177	2.4	4.0	4.0	5.0	4.2	3.9
184	-	2.5	2.8	4.6	2.8	3.5
190	-	-	-	4.2	-	3.3
197	-	-	-	2.8	-	3.0
203	-	-	-	-	-	2.6

68,400 lb   360° 85%

Radius	Fly jib					
	65.8 ft		105.0 ft		134.5 ft	
	3°	20°	3°	20°	3°	20°
ft	1,000 lb					
59	21.3	-	-	-	-	-
65	20.3	-	14.5	-	-	-
72	19.2	16.3	14.1	-	8.6	-
79	18.2	15.6	13.6	-	8.8	-
85	17.2	15.0	13.2	-	8.6	-
92	15.8	14.3	12.5	-	8.3	-
98	12.7	13.7	12.1	10.4	8.1	-
105	9.9	12.7	10.7	9.6	7.7	-
111	7.7	10.9	8.5	9.2	7.5	6.8
118	5.1	8.4	6.4	8.8	5.9	6.4
124	3.6	6.5	4.6	8.4	4.1	6.1
131	-	4.4	2.7	7.1	2.4	5.9
138	-	2.6	-	5.2	-	6.4
144	-	-	-	3.8	-	4.8
151	-	-	-	2.4	-	3.0
157	-	-	-	-	-	-
164	-	-	-	-	-	-
170	-	-	-	-	-	-
177	-	-	-	-	-	-
184	-	-	-	-	-	-
190	-	-	-	-	-	-
197	-	-	-	-	-	-
203	-	-	-	-	-	-

Remarks

¹⁾ plus 9.8 ft adapter

WALD SALES & RENTAL

Working ranges fixed fly jib

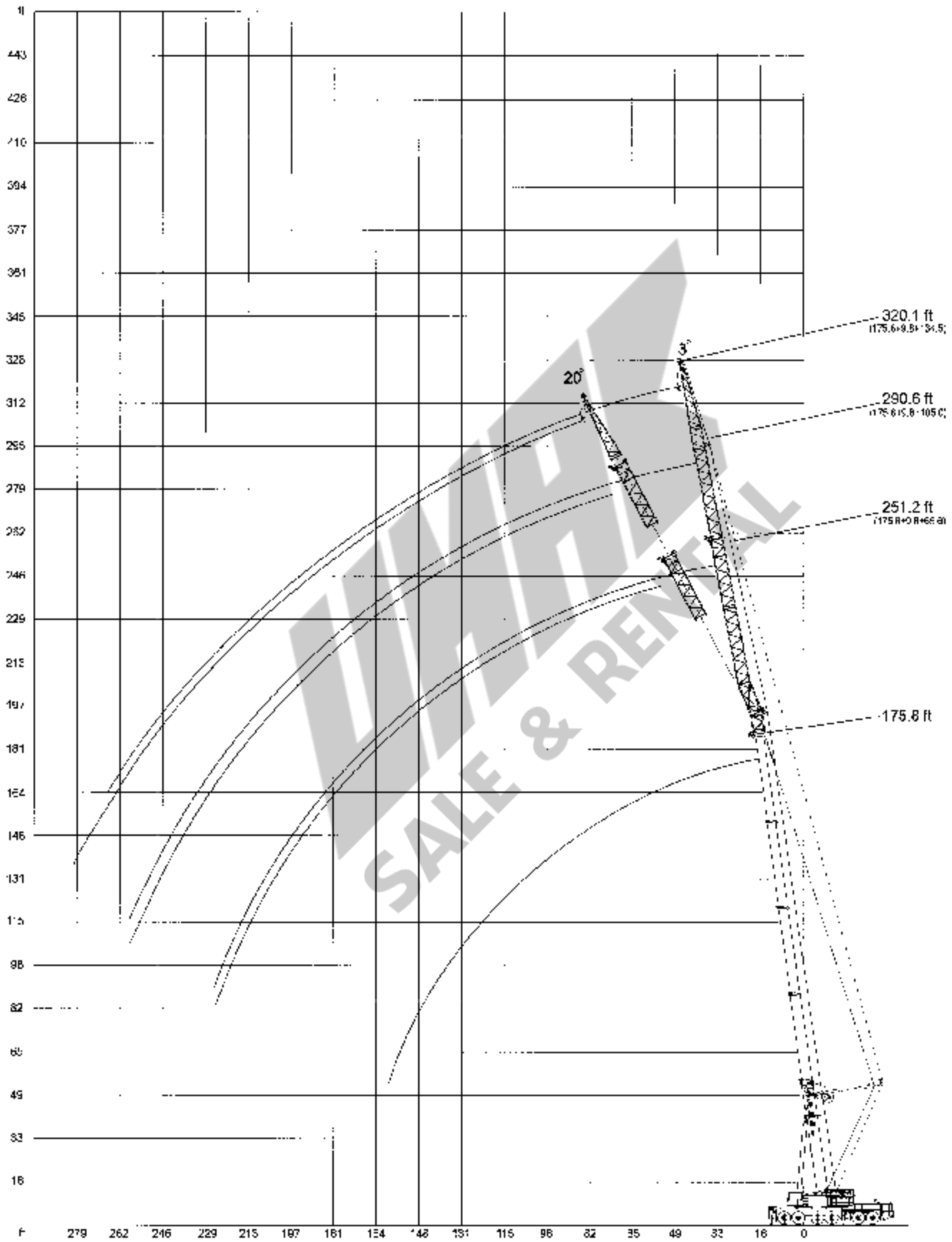

Working ranges luffing fly jib with SL, main boom 82° to 60°

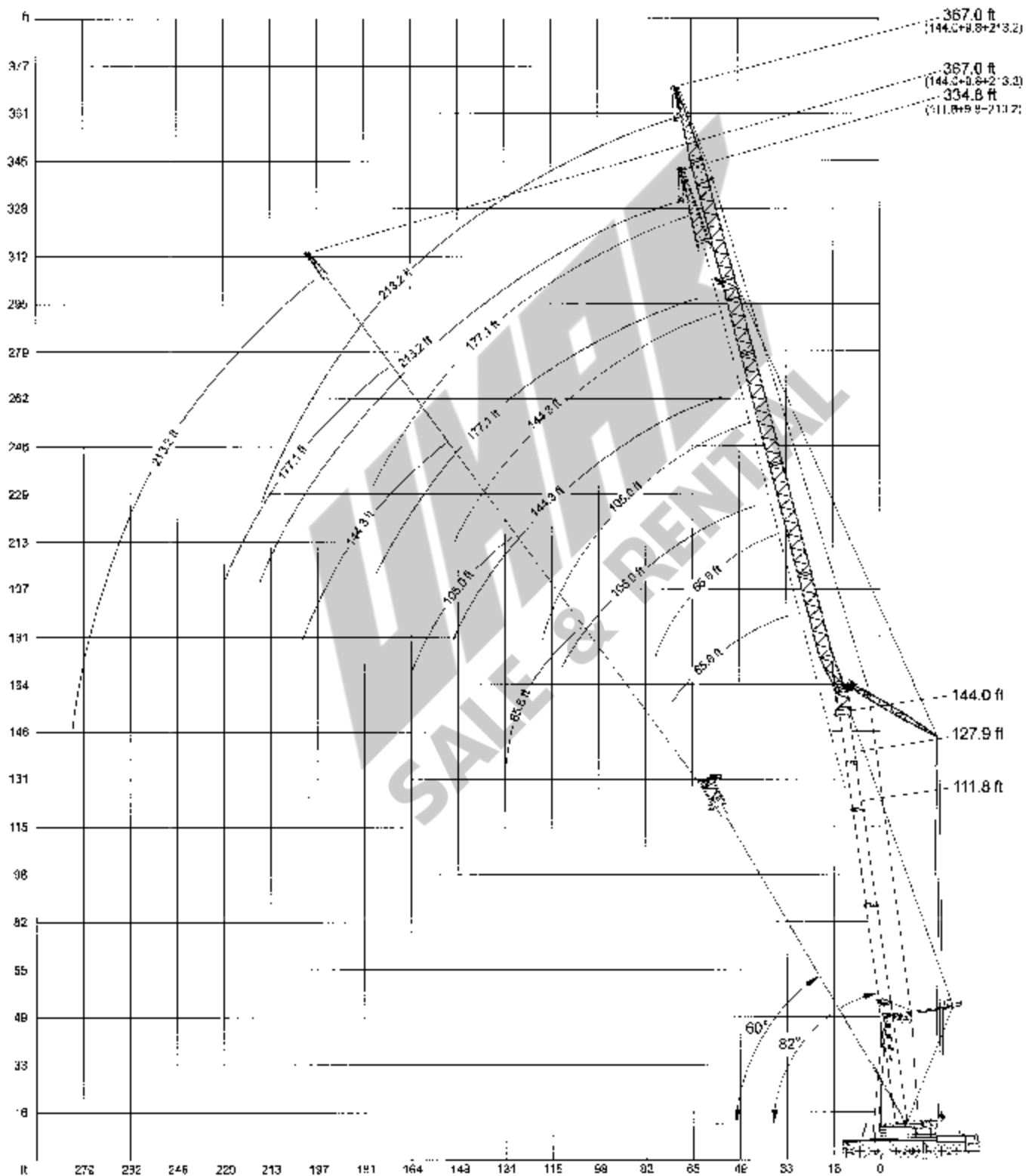

Lifting capacities luffing fly jib with SL, main boom 82° to 60°

Main boom: 111.8 ft¹⁾

220,500 lb

360°

75%

Radius	Fly jib																			
	65.3 ft*				105.0 ft**				144.3 ft				177.1 ft				213.2 ft***			
	82°	73°	65°	60°	82°	73°	65°	60°	82°	73°	65°	60°	82°	73°	65°	60°	82°	73°	65°	60°
ft	1,000 lb																			
46	35.2	-	-	-	-	-	-	-	-	-	-	-	-	-	-	-	-	-	-	-
52	35.2	-	-	-	25.1	-	-	-	-	-	-	-	-	-	-	-	-	-	-	-
59	35.2	-	-	-	25.1	-	-	-	-	-	-	-	-	-	-	-	-	-	-	-
65	35.2	-	-	-	25.1	-	-	-	8.0	-	-	-	-	-	-	-	-	-	-	-
72	35.2	35.2	-	-	25.1	-	-	-	8.0	-	-	-	-	-	-	-	-	-	-	-
79	-	35.2	-	-	25.1	-	-	-	8.0	-	-	-	14.5	-	-	-	-	-	-	-
85	-	35.2	-	-	25.1	-	-	-	18.0	-	-	-	14.5	-	-	-	8.8	-	-	-
92	-	35.2	35.2	-	25.1	25.1	-	-	18.0	-	-	-	14.5	-	-	-	8.8	-	-	-
98	-	-	35.2	-	25.1	25.1	-	-	18.0	-	-	-	14.5	-	-	-	8.8	-	-	-
105	-	-	35.2	35.2	25.1	25.1	-	-	18.0	18.0	-	-	4.5	-	-	-	8.8	-	-	-
111	-	-	-	33.0	25.1	25.1	-	-	18.0	18.0	-	-	4.5	-	-	-	8.8	-	-	-
118	-	-	-	30.8	25.1	25.1	-	-	18.0	18.0	-	-	4.5	14.5	-	-	8.8	-	-	-
124	-	-	-	-	25.1	25.1	-	-	18.0	18.0	-	-	14.5	14.5	-	-	8.8	-	-	-
131	-	-	-	-	25.1	25.1	25.1	-	18.0	18.0	-	-	14.5	14.5	-	-	8.8	8.8	-	-
138	-	-	-	-	-	23.7	23.7	18.0	18.0	18.0	18.0	-	14.5	14.5	-	-	8.8	8.8	-	-
144	-	-	-	-	-	22.8	22.8	18.0	18.0	18.0	18.0	-	14.5	14.5	-	-	8.8	8.8	-	-
151	-	-	-	-	-	-	21.1	16.0	18.0	18.0	18.0	-	14.5	14.5	-	-	8.8	8.8	-	-
157	-	-	-	-	-	-	20.3	-	18.0	18.0	18.0	-	14.5	14.5	14.5	-	8.8	8.8	-	-
164	-	-	-	-	-	-	-	-	16.9	16.9	16.9	-	14.5	14.5	14.5	-	8.8	8.8	-	-
172	-	-	-	-	-	-	-	-	-	15.2	15.2	-	14.5	14.5	14.5	14.5	8.8	8.8	8.8	-
190	-	-	-	-	-	-	-	-	-	-	13.9	-	-	13.4	13.4	13.4	8.8	8.8	8.8	-
203	-	-	-	-	-	-	-	-	-	-	-	-	-	-	12.1	12.1	8.8	8.8	8.8	8.8
216	-	-	-	-	-	-	-	-	-	-	-	-	-	-	11.0	6.8	8.8	8.8	8.8	8.8
229	-	-	-	-	-	-	-	-	-	-	-	-	-	-	-	-	8.8	8.8	8.8	-
243	-	-	-	-	-	-	-	-	-	-	-	-	-	-	-	-	-	7.7	7.7	-
256	-	-	-	-	-	-	-	-	-	-	-	-	-	-	-	-	-	-	7.0	-

Remarks

1) plus 9.8 ft adaptor

* required weight of hook block + complementary weight on fly jib = 8,636 lb

** required weight of hook block + complementary weight on fly jib = 3,308 lb

*** max. wind speed 19.3 mph

Complementary weight and hook block are part of the load

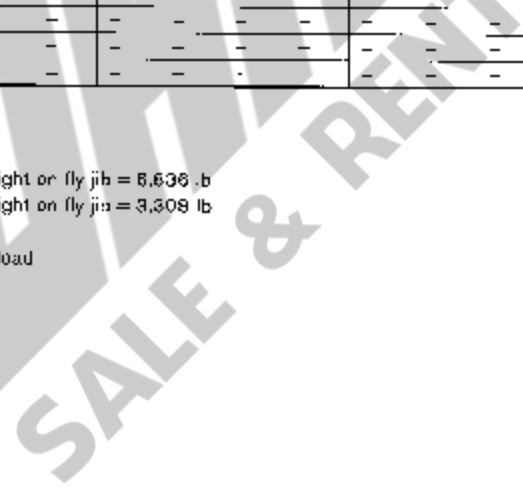

Lifting capacities luffing fly jib with SL, main boom 82° to 60°

Main boom: 127.9 ft¹⁾

220,500 lb

360°

75%

Radius ft	Fly jib																			
	85.6 ft*				105.0 ft**				144.3 ft				177.1 ft				213.2 ft***			
	82°	73°	65°	60°	82°	73°	65°	60°	82°	73°	65°	60°	82°	73°	65°	60°	82°	73°	65°	60°
	1,000 lb																			
46	30.2	-	-	-	-	-	-	-	-	-	-	-	-	-	-	-	-	-	-	-
52	30.2	-	-	-	-	-	-	-	-	-	-	-	-	-	-	-	-	-	-	-
59	30.2	-	-	-	23.1	-	-	-	-	-	-	-	-	-	-	-	-	-	-	-
65	30.2	-	-	-	23.1	-	-	-	-	-	-	-	-	-	-	-	-	-	-	-
72	30.2	-	-	-	23.1	-	-	-	16.5	-	-	-	-	-	-	-	-	-	-	-
79	-	30.2	-	-	23.1	-	-	-	16.5	-	-	-	-	-	-	-	-	-	-	-
85	-	30.2	-	-	23.1	-	-	-	16.5	-	-	-	10.1	-	-	-	-	-	-	-
92	-	30.2	-	-	23.1	23.1	-	-	16.5	-	-	-	10.1	-	-	-	5.7	-	-	-
98	-	30.2	30.2	-	23.1	23.1	-	-	16.5	-	-	-	10.1	-	-	-	5.7	-	-	-
105	-	-	30.2	-	23.1	23.1	-	-	16.5	-	-	-	10.1	-	-	-	5.7	-	-	-
111	-	-	30.2	-	23.1	23.1	-	-	16.5	16.5	-	-	10.1	-	-	-	5.7	-	-	-
118	-	-	-	30.2	-	23.1	23.1	-	16.5	16.5	-	-	10.1	-	-	-	5.7	-	-	-
124	-	-	-	28.6	-	23.1	23.1	-	16.5	16.5	-	-	10.1	-	-	-	5.7	-	-	-
131	-	-	-	-	-	23.1	23.1	-	16.5	16.5	-	-	10.1	0.1	-	-	5.7	-	-	-
138	-	-	-	-	-	23.1	23.1	-	16.5	16.5	-	-	10.1	0.1	-	-	5.7	-	-	-
144	-	-	-	-	-	-	21.3	21.8	16.5	16.5	16.5	-	10.1	0.1	-	-	5.7	5.7	-	-
151	-	-	-	-	-	-	20.4	20.4	16.5	16.5	16.5	-	10.1	0.1	-	-	5.7	5.7	-	-
157	-	-	-	-	-	-	-	19.6	-	16.5	16.5	-	10.1	0.1	-	-	5.7	5.7	-	-
164	-	-	-	-	-	-	-	18.5	-	16.5	16.5	16.5	10.1	0.1	10.1	-	5.7	5.7	-	-
177	-	-	-	-	-	-	-	-	-	-	14.7	14.7	10.1	0.1	10.1	-	5.7	5.7	-	-
190	-	-	-	-	-	-	-	-	-	-	-	13.2	13.2	-	0.1	10.1	10.1	6.7	5.7	5.7
203	-	-	-	-	-	-	-	-	-	-	-	-	12.1	-	0.1	10.1	10.1	5.7	5.7	5.7
216	-	-	-	-	-	-	-	-	-	-	-	-	-	-	10.1	10.1	5.7	5.7	5.7	5.7
229	-	-	-	-	-	-	-	-	-	-	-	-	-	-	-	9.7	-	5.7	5.7	5.7
243	-	-	-	-	-	-	-	-	-	-	-	-	-	-	-	-	-	-	5.7	5.7
258	-	-	-	-	-	-	-	-	-	-	-	-	-	-	-	-	-	-	-	5.7
269	-	-	-	-	-	-	-	-	-	-	-	-	-	-	-	-	-	-	-	5.7

Remarks

¹⁾ plus 9.8 ft adapter

^{*} required weight of hook block + complementary weight on fly jib = 6,898 lb

^{**} required weight of hook block + complementary weight on fly jib = 3,308 lb

^{***} max. wind speed 13.3 mph

Complementary weight and hook block are part of the load

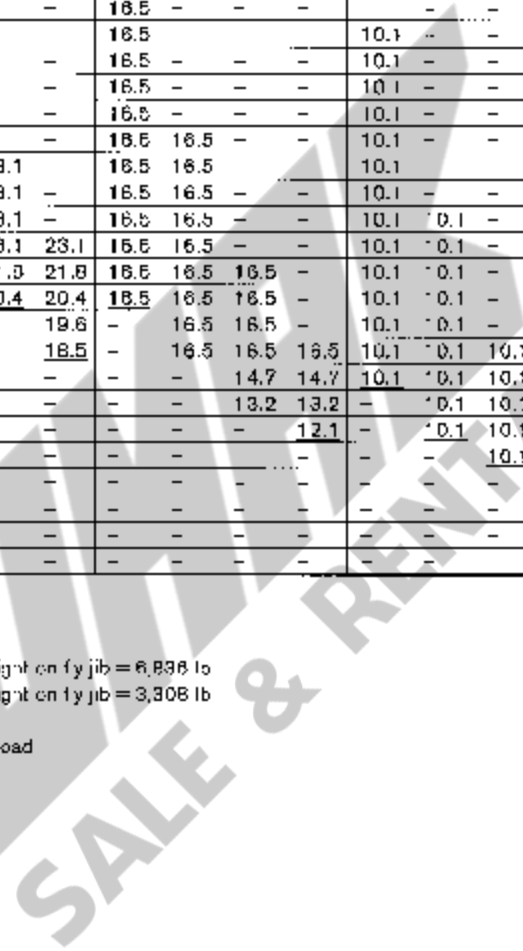

Lifting capacities luffing fly jib with SL, main boom 82° to 60°

Main boom: 144.0 ft¹⁾

220,500 lb

360°

75%

Radius ft	Fly jib																			
	85.6 ft*				105.0 ft**				144.3 ft				177.1 ft				213.2 ft***			
	82°	73°	65°	60°	82°	73°	65°	60°	82°	73°	65°	60°	82°	73°	65°	60°	82°	73°	65°	60°
	1,000 lb																			
48	27.9	-	-	-	-	-	-	-	-	-	-	-	-	-	-	-	-	-	-	-
52	27.9	-	-	-	-	-	-	-	-	-	-	-	-	-	-	-	-	-	-	-
59	27.9	-	-	-	19.8	-	-	-	-	-	-	-	-	-	-	-	-	-	-	-
65	27.9	-	-	-	19.8	-	-	-	-	-	-	-	-	-	-	-	-	-	-	-
72	27.9	-	-	-	19.8	-	-	-	12.1	-	-	-	-	-	-	-	-	-	-	-
79	27.9	27.9	-	-	19.8	-	-	-	12.1	-	-	-	6.6	-	-	-	-	-	-	-
85	-	27.9	-	-	19.8	-	-	-	12.1	-	-	-	6.6	-	-	-	-	-	-	-
92	-	27.9	-	-	19.8	-	-	-	12.1	-	-	-	6.6	-	-	-	3.3	-	-	-
98	-	27.9	-	-	19.8	19.8	-	-	12.1	-	-	-	6.6	-	-	-	3.3	-	-	-
105	-	27.9	-	-	19.8	19.8	-	-	12.1	-	-	-	6.6	-	-	-	3.3	-	-	-
111	-	27.9	-	-	19.8	19.8	-	-	12.1	-	-	-	6.6	-	-	-	3.3	-	-	-
118	-	27.9	27.9	-	19.8	19.8	-	-	12.1	12.1	-	-	6.6	-	-	-	3.3	-	-	-
124	-	-	26.6	-	-	19.8	-	-	12.1	12.1	-	-	6.6	-	-	-	3.3	-	-	-
131	-	-	24.9	-	-	19.8	19.8	-	12.1	12.1	-	-	6.6	6.6	-	-	3.3	-	-	-
138	-	-	-	-	-	19.8	19.8	-	12.1	12.1	-	-	6.6	6.6	-	-	3.3	-	-	-
144	-	-	-	-	-	19.8	19.8	-	12.1	12.1	-	-	6.6	6.6	-	-	3.3	3.3	-	-
151	-	-	-	-	-	18.7	18.7	-	12.1	12.1	-	-	6.6	6.6	-	-	3.3	3.3	-	-
157	-	-	-	-	-	17.9	17.9	-	12.1	12.1	-	-	6.6	6.6	-	-	3.3	3.3	-	-
164	-	-	-	-	-	-	16.9	-	12.1	12.1	-	-	6.6	6.6	6.6	-	3.3	3.3	-	-
177	-	-	-	-	-	-	-	-	12.1	12.1	12.1	-	6.6	6.6	6.6	-	3.3	3.3	-	-
190	-	-	-	-	-	-	-	-	-	11.6	11.6	-	6.6	6.6	6.6	-	3.3	3.3	3.3	-
203	-	-	-	-	-	-	-	-	-	10.6	-	-	6.6	6.6	6.6	-	3.3	3.3	3.3	-
216	-	-	-	-	-	-	-	-	-	-	-	-	6.6	6.6	-	-	3.3	3.3	3.3	3.3
229	-	-	-	-	-	-	-	-	-	-	-	-	6.6	-	-	-	3.3	3.3	3.3	3.3
243	-	-	-	-	-	-	-	-	-	-	-	-	-	-	-	-	3.3	3.3	3.3	3.3
256	-	-	-	-	-	-	-	-	-	-	-	-	-	-	-	-	-	3.3	3.3	3.3
269	-	-	-	-	-	-	-	-	-	-	-	-	-	-	-	-	-	-	-	3.3
275	-	-	-	-	-	-	-	-	-	-	-	-	-	-	-	-	-	-	-	3.3

Remarks

- ¹⁾ plus 9.8 ft adapter
 - * required weight of hook block – complementary weight on fly jib = 6 836 lb
 - ** required weight of hook block – complementary weight on fly jib = 8 308 lb
 - *** max. wind speed 13.3 mph
- Complementary weight and hook block are part of the load

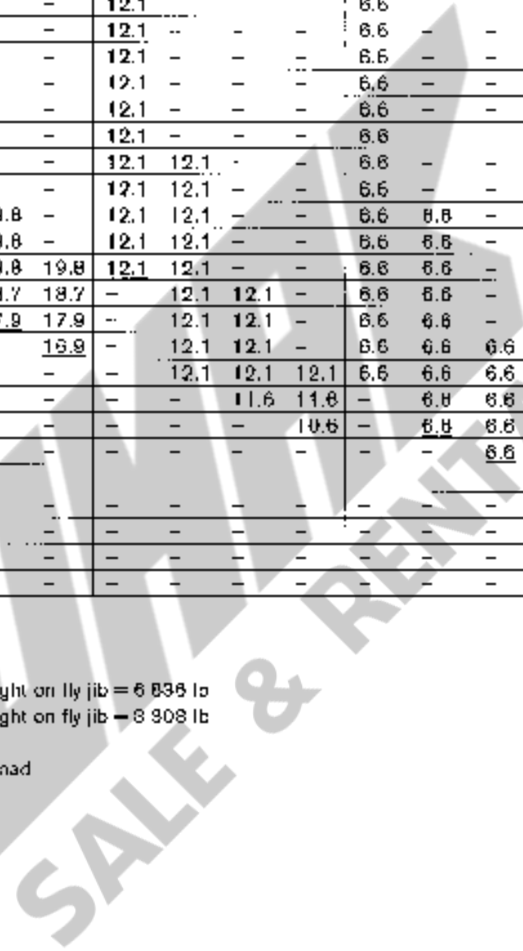

Working ranges luffing fly jib, main boom 82° to 65°

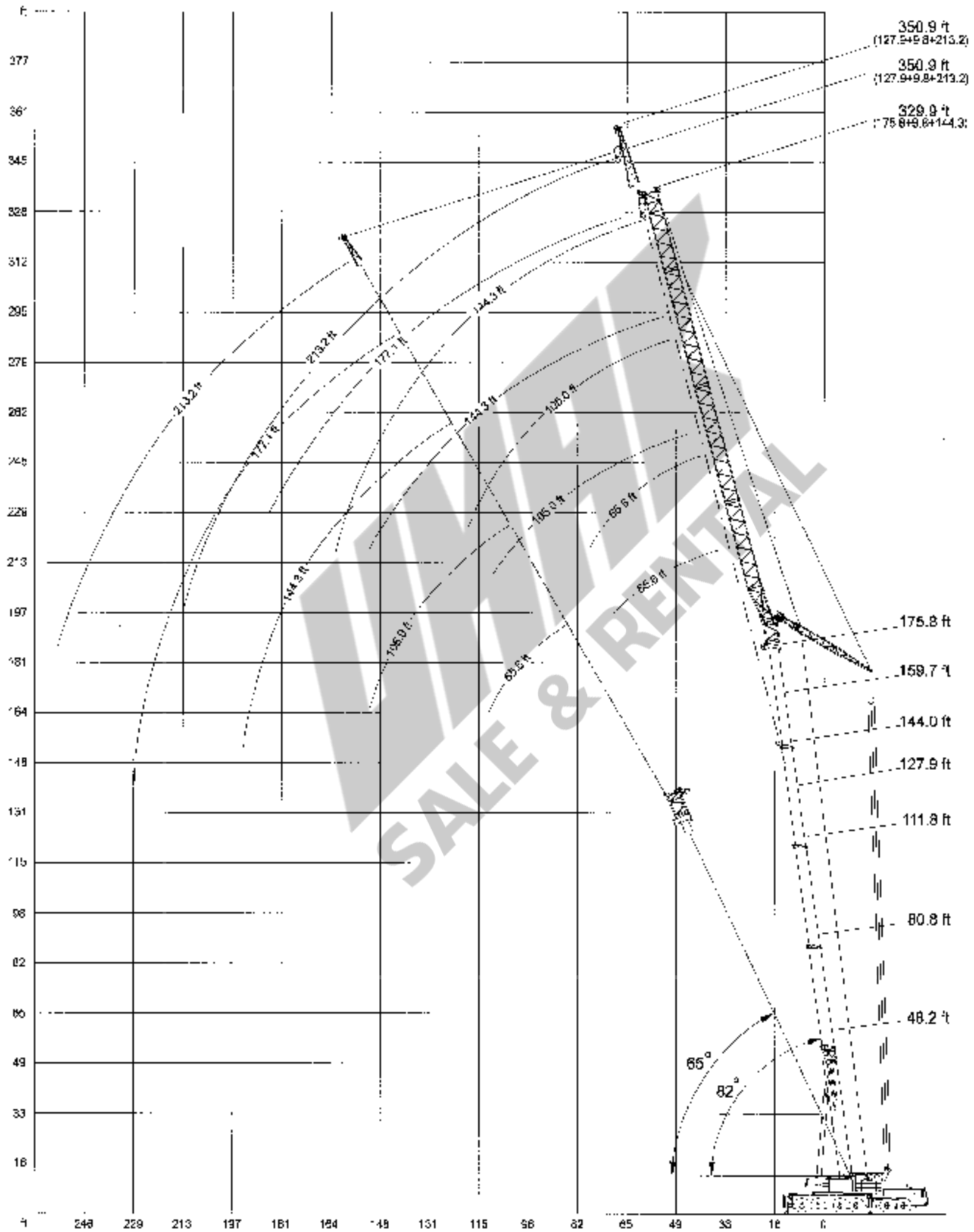

Lifting capacities luffing fly jib, main boom 82° to 65°

Main boom: 48.2 ft²⁾

116,900 lb¹⁾ / 167,600 lb



360°

75%

Radius ft	Fly jib														
	65.6 ft ¹⁾			105.0 ft ²⁾			144.3 ft			177.1 ft			219.2 ft ³⁾		
	82°	73°	65°	82°	73°	65°	82°	73°	65°	82°	73°	65°	82°	73°	65°
	1,000 lb														
29	119.0	-	-	-	-	-	-	-	-	-	-	-	-	-	-
33	118.5	-	-	-	-	-	-	-	-	-	-	-	-	-	-
39	117.5	-	-	70.5	-	-	-	-	-	-	-	-	-	-	-
46	100.0	-	-	70.5	-	-	-	-	-	-	-	-	-	-	-
52	88.0	94.5	-	89.5	-	-	44.0	-	-	-	-	-	-	-	-
59	76.0	82.5	-	87.0	-	-	44.0	-	-	29.7	-	-	-	-	-
65	89.0	74.5	71.0	66.0	-	-	44.0	-	-	29.7	-	-	-	-	-
72	-	66.0	63.5	59.9	62.0	-	44.0	-	-	29.9	-	-	-	-	-
79	-	-	57.7	54.0	58.6	-	42.9	-	-	28.8	-	-	20.2	-	-
85	-	-	-	49.8	54.0	-	42.1	-	-	28.4	-	-	20.0	-	-
92	-	-	-	45.3	49.3	46.8	41.2	41.4	-	28.2	-	-	19.6	-	-
98	-	-	-	41.9	46.0	43.6	40.1	41.0	-	27.8	-	-	19.4	-	-
105	-	-	-	-	42.5	40.3	36.8	40.3	-	27.3	26.8	-	19.1	-	-
111	-	-	-	-	39.9	37.9	34.1	36.1	35.9	27.1	26.6	-	18.9	-	-
118	-	-	-	-	-	35.3	31.5	35.5	33.3	26.8	26.4	-	18.7	17.4	-
124	-	-	-	-	-	-	29.6	33.3	31.5	26.4	26.2	26.2	18.5	17.4	-
131	-	-	-	-	-	-	27.4	31.1	29.3	26.0	26.0	26.0	18.5	17.2	-
138	-	-	-	-	-	-	25.5	29.2	27.5	25.3	25.7	25.7	18.2	16.9	-
144	-	-	-	-	-	-	-	27.8	26.0	24.1	25.7	25.5	18.0	16.7	16.5
151	-	-	-	-	-	-	-	26.2	24.6	22.4	25.6	24.4	17.8	16.5	16.3
157	-	-	-	-	-	-	-	-	23.4	21.2	24.7	23.2	17.6	16.3	16.3
164	-	-	-	-	-	-	-	-	-	20.0	23.3	21.6	17.4	16.0	16.0
170	-	-	-	-	-	-	-	-	-	19.0	22.3	20.6	17.2	15.8	15.0
177	-	-	-	-	-	-	-	-	-	-	21.1	19.6	18.7	15.8	15.8
184	-	-	-	-	-	-	-	-	-	-	-	18.5	15.8	15.4	15.6
190	-	-	-	-	-	-	-	-	-	-	-	18.1	15.0	15.2	15.4
197	-	-	-	-	-	-	-	-	-	-	-	-	14.0	14.9	15.2
200	-	-	-	-	-	-	-	-	-	-	-	-	13.4	14.5	15.0
210	-	-	-	-	-	-	-	-	-	-	-	-	-	14.3	14.5
216	-	-	-	-	-	-	-	-	-	-	-	-	-	14.1	13.9
223	-	-	-	-	-	-	-	-	-	-	-	-	-	-	13.2

Remarks

¹⁾ Boom angle 82°

²⁾ plus 9.8 ft adapter

^{*)} required weight of hook block + complementary weight on fly jib = 6,836 lb

^{**} required weight of hook block + complementary weight on fly jib = 3,306 lb

^{***} max. wind speed 13.3 mph

Complementary weight and hook block are part of the load

Lifting capacities luffing fly jib, main boom 82° to 65°

Main boom: 48.2 ft²⁾

116,900 lb¹⁾ / 167,600 lb



360°

75%

Radius ft	Fly jib														
	65.6 ft ¹⁾			105.0 ft ¹⁾			144.3 ft			177.1 ft			219.2 ft ³⁾		
	82°	73°	65°	82°	73°	65°	82°	73°	65°	82°	73°	65°	82°	73°	65°
	1,000 lb														
29	119.0	-	-	-	-	-	-	-	-	-	-	-	-	-	-
33	118.5	-	-	-	-	-	-	-	-	-	-	-	-	-	-
39	117.5	-	-	70.5	-	-	-	-	-	-	-	-	-	-	-
46	100.0	-	-	70.5	-	-	-	-	-	-	-	-	-	-	-
52	88.0	94.5	-	89.5	-	-	44.0	-	-	-	-	-	-	-	-
59	76.0	82.5	-	87.0	-	-	44.0	-	-	29.7	-	-	-	-	-
65	89.0	74.5	71.0	66.0	-	-	44.0	-	-	29.7	-	-	-	-	-
72	-	66.0	63.5	59.9	62.0	-	44.0	-	-	29.9	-	-	-	-	-
79	-	-	57.7	54.0	58.6	-	42.9	-	-	28.8	-	-	20.2	-	-
85	-	-	-	49.8	54.0	-	42.1	-	-	28.4	-	-	20.0	-	-
92	-	-	-	45.3	49.3	46.8	41.2	41.4	-	28.2	-	-	19.6	-	-
98	-	-	-	41.9	46.0	43.6	40.1	41.0	-	27.9	-	-	19.4	-	-
105	-	-	-	-	42.5	40.3	36.8	40.3	-	27.3	26.8	-	19.1	-	-
111	-	-	-	-	39.9	37.9	34.1	36.1	35.9	27.1	26.6	-	18.9	-	-
118	-	-	-	-	-	35.3	31.5	35.5	33.3	26.8	26.4	-	18.7	17.4	-
124	-	-	-	-	-	-	29.6	33.3	31.5	26.4	26.2	26.2	18.5	17.4	-
131	-	-	-	-	-	-	27.4	31.1	29.3	26.0	26.0	26.0	18.5	17.2	-
138	-	-	-	-	-	-	25.5	29.2	27.5	25.3	25.7	25.7	18.2	16.9	-
144	-	-	-	-	-	-	-	27.8	26.0	24.1	25.7	25.5	18.0	16.7	16.5
151	-	-	-	-	-	-	-	26.2	24.6	22.4	25.6	24.4	17.8	16.5	16.3
157	-	-	-	-	-	-	-	-	23.4	21.2	24.7	23.2	17.6	16.3	16.3
164	-	-	-	-	-	-	-	-	-	20.0	23.3	21.6	17.4	16.0	16.0
170	-	-	-	-	-	-	-	-	-	19.0	22.3	20.6	17.2	15.8	15.0
177	-	-	-	-	-	-	-	-	-	-	21.1	19.6	18.7	15.8	15.8
184	-	-	-	-	-	-	-	-	-	-	-	18.5	15.8	15.4	15.6
190	-	-	-	-	-	-	-	-	-	-	-	18.1	15.0	15.2	15.4
197	-	-	-	-	-	-	-	-	-	-	-	-	14.0	14.9	15.2
200	-	-	-	-	-	-	-	-	-	-	-	-	13.4	14.5	15.0
210	-	-	-	-	-	-	-	-	-	-	-	-	-	14.3	14.5
216	-	-	-	-	-	-	-	-	-	-	-	-	-	14.1	13.9
223	-	-	-	-	-	-	-	-	-	-	-	-	-	-	13.2

Remarks

¹⁾ Boom angle 82°

²⁾ plus 9.8 ft adapter

⁴⁾ required weight of hook block + complementary weight on fly jib = 6,836 lb

⁵⁾ required weight of hook block + complementary weight on fly jib = 3,306 lb

³⁾ max. wind speed 13.3 mph

Complementary weight and hook block are part of the load

Lifting capacities luffing fly jib, main boom 82° to 65°

Main boom: 80.0 ft²⁾

116,900 lb¹⁾ / 167,600 lb

 360°

75%

Radius	Fly jib														
	85.6 ft ³⁾			105.0 ft ³⁾			144.3 ft			177.1 ft			213.2 ft ³⁾		
	82°	73°	65°	82°	73°	65°	82°	73°	65°	82°	73°	65°	82°	73°	65°
t	,000 lb														
39	98.0	-	-	-	-	-	-	-	-	-	-	-	-	-	-
46	94.5	-	-	-	-	-	-	-	-	-	-	-	-	-	-
52	84.5	-	-	81.0	-	-	-	-	-	-	-	-	-	-	-
59	72.5	-	-	60.0	-	-	-	-	-	-	-	-	-	-	-
65	68.0	68.5	-	59.4	-	-	39.9	-	-	-	-	-	-	-	-
72	-	62.0	-	57.8	-	-	39.9	-	-	26.4	-	-	-	-	-
79	-	56.0	51.6	51.6	54.2	-	39.4	-	-	26.2	-	-	-	16.5	-
85	-	51.8	47.6	47.6	49.8	-	38.6	-	-	25.8	-	-	-	16.1	-
92	-	-	43.5	43.1	45.5	-	37.6	36.1	-	25.3	-	-	-	15.6	-
98	-	-	-	39.9	42.9	38.5	36.6	35.9	-	24.7	-	-	-	15.2	-
105	-	-	-	36.3	39.0	35.4	35.0	35.4	-	24.0	-	-	-	14.9	-
111	-	-	-	-	36.5	33.2	32.4	34.6	-	23.4	23.4	-	-	14.7	-
118	-	-	-	-	34.2	30.9	29.8	32.4	-	22.9	22.9	-	-	14.3	-
124	-	-	-	-	-	29.2	27.9	30.4	27.2	22.9	22.5	-	-	14.1	14.1
131	-	-	-	-	-	27.4	25.8	28.5	25.4	21.6	22.0	-	-	13.8	13.8
138	-	-	-	-	-	-	23.9	26.6	23.7	20.9	21.5	21.6	-	13.6	13.4
144	-	-	-	-	-	-	22.7	25.2	22.3	20.3	21.1	21.6	-	13.4	13.2
151	-	-	-	-	-	-	-	23.7	21.1	19.8	20.9	20.9	-	13.2	13.0
157	-	-	-	-	-	-	-	22.5	20.1	19.4	20.7	19.9	-	13.0	12.8
164	-	-	-	-	-	-	-	-	18.9	18.9	20.5	18.7	-	12.7	12.5
170	-	-	-	-	-	-	-	-	17.9	17.9	20.1	17.9	-	12.7	12.3
177	-	-	-	-	-	-	-	-	-	16.7	19.2	16.7	-	12.5	12.1
184	-	-	-	-	-	-	-	-	-	-	18.0	16.0	-	12.5	12.1
190	-	-	-	-	-	-	-	-	-	-	17.4	15.2	-	12.3	11.9
197	-	-	-	-	-	-	-	-	-	-	-	14.5	-	12.3	11.6
203	-	-	-	-	-	-	-	-	-	-	-	13.9	-	12.1	11.5
210	-	-	-	-	-	-	-	-	-	-	-	-	-	11.9	11.8
216	-	-	-	-	-	-	-	-	-	-	-	-	-	-	11.4
223	-	-	-	-	-	-	-	-	-	-	-	-	-	-	11.4
229	-	-	-	-	-	-	-	-	-	-	-	-	-	-	9.6

Remarks

¹⁾ Boom angle 82°

²⁾ plus 9.8 ft adapter

* required weight of hook block + complementary weight on fly jib = 6.836 lb

** required weight of hook block + complementary weight on fly jib = 3.308 lb

³⁾ max. wind speed 19.3 mph

Complementary weight and hook block are part of the load

Lifting capacities luffing fly jib, main boom 82° to 65°

Main boom: 111.8 ft²⁾

116,900 lb¹⁾ / 167,600 lb

360°

75%

Radius ft	65.6 ft ¹⁾			105.0 ft ²⁾			144.3 ft			177.1 ft			213.2 ft ³⁾		
	82°	73°	65°	82°	73°	65°	82°	73°	65°	82°	73°	65°	82°	73°	65°
	Fly jib 1,000 lb														
46	69.0	-	-	-	-	-	-	-	-	-	-	-	-	-	-
52	64.0	-	-	43.5	-	-	-	-	-	-	-	-	-	-	-
59	58.9	-	-	41.9	-	-	-	-	-	-	-	-	-	-	-
65	56.4	-	-	40.8	-	-	28.6	-	-	-	-	-	-	-	-
72	55.1	47.9	-	40.1	-	-	28.6	-	-	-	-	-	-	-	-
79	-	44.4	-	39.3	-	-	28.6	-	-	17.3	-	-	-	-	-
85	-	42.4	-	39.3	-	-	28.6	-	-	16.9	-	-	-	-	-
92	-	40.5	34.3	39.3	35.0	-	28.6	-	-	16.7	-	-	11.0	-	-
98	-	-	32.5	37.8	33.6	-	28.6	-	-	16.3	-	-	11.0	-	-
105	-	-	31.0	34.6	31.0	-	28.6	25.5	-	16.0	-	-	11.0	-	-
111	-	-	-	32.1	30.9	-	28.6	24.0	-	15.6	-	-	11.0	-	-
118	-	-	-	-	29.9	24.7	28.2	24.4	-	15.4	15.4	-	10.8	-	-
124	-	-	-	-	26.9	23.5	26.4	23.8	-	15.2	15.0	-	10.8	-	-
131	-	-	-	-	27.3	22.5	24.3	23.1	-	14.9	14.7	-	10.5	9.2	-
138	-	-	-	-	-	21.5	22.6	22.6	18.4	14.9	14.5	-	10.5	9.2	-
144	-	-	-	-	-	20.7	21.2	22.0	17.6	14.7	14.3	-	10.3	9.0	-
151	-	-	-	-	-	-	20.0	21.1	18.7	14.7	14.1	-	10.3	9.0	-
157	-	-	-	-	-	-	-	20.1	15.9	14.7	14.1	12.8	10.3	8.8	-
164	-	-	-	-	-	-	-	18.9	15.2	14.7	13.8	12.1	10.1	8.8	-
170	-	-	-	-	-	-	-	18.1	14.8	14.7	13.6	11.5	10.1	8.6	7.8
177	-	-	-	-	-	-	-	-	13.9	14.7	13.6	11.0	9.9	8.5	7.8
184	-	-	-	-	-	-	-	-	12.9	-	13.6	10.3	9.8	8.5	7.8
190	-	-	-	-	-	-	-	-	-	-	13.4	9.9	9.9	8.3	7.7
197	-	-	-	-	-	-	-	-	-	-	13.4	9.8	9.9	8.3	7.7
203	-	-	-	-	-	-	-	-	-	-	-	9.2	9.7	8.3	7.5
210	-	-	-	-	-	-	-	-	-	-	-	9.0	9.7	8.3	7.4
216	-	-	-	-	-	-	-	-	-	-	-	8.8	9.7	8.3	7.2
223	-	-	-	-	-	-	-	-	-	-	-	-	-	8.3	7.0
229	-	-	-	-	-	-	-	-	-	-	-	-	-	8.0	7.0
243	-	-	-	-	-	-	-	-	-	-	-	-	-	-	6.1

Remarks

- 1) Boom angle 82°
 - 2) plus 9.8 ft adapter
 - *) required weight of hook block + complementary weight on fly jib = 6,836 lb
 - ** required weight of hook block + complementary weight on fly jib = 9,308 lb
 - *** max. wind speed 19.3 mph
- Complementary weight and hook block are part of the load

Lifting capacities luffing fly jib, main boom 82° to 65°

Main boom: 111.8 ft²⁾

116,900 lb¹⁾ / 167,600 lb

360°

75%

Radius ft	Fly jib														
	65.6 ft ¹⁾			105.0 ft ²⁾			144.3 ft			177.1 ft			213.2 ft ³⁾		
	82°	73°	65°	82°	73°	65°	82°	73°	65°	82°	73°	65°	82°	73°	65°
	1,000 lb														
46	69.0	-	-	-	-	-	-	-	-	-	-	-	-	-	-
52	64.0	-	-	43.5	-	-	-	-	-	-	-	-	-	-	-
59	58.9	-	-	41.9	-	-	-	-	-	-	-	-	-	-	-
65	56.4	-	-	40.8	-	-	28.6	-	-	-	-	-	-	-	-
72	55.1	47.9	-	40.1	-	-	28.6	-	-	-	-	-	-	-	-
79	-	44.4	-	39.3	-	-	28.6	-	-	17.3	-	-	-	-	-
85	-	42.4	-	39.3	-	-	28.6	-	-	16.9	-	-	-	-	-
92	-	40.5	34.3	39.3	35.0	-	28.6	-	-	16.7	-	-	11.0	-	-
98	-	-	32.5	37.8	33.6	-	28.6	-	-	16.3	-	-	11.0	-	-
105	-	-	31.0	34.6	31.0	-	28.6	25.5	-	16.0	-	-	11.0	-	-
111	-	-	-	32.1	30.9	-	28.6	24.0	-	15.6	-	-	11.0	-	-
118	-	-	-	-	29.9	24.7	28.2	24.4	-	15.4	15.4	-	10.8	-	-
124	-	-	-	-	26.9	23.5	26.4	23.8	-	15.2	15.0	-	10.8	-	-
131	-	-	-	-	27.3	22.5	24.3	23.1	-	14.9	14.7	-	10.5	9.2	-
138	-	-	-	-	-	21.5	22.6	22.6	18.4	14.9	14.5	-	10.5	9.2	-
144	-	-	-	-	-	20.7	21.2	22.0	17.6	14.7	14.3	-	10.3	9.0	-
151	-	-	-	-	-	-	20.0	21.1	18.7	14.7	14.1	-	10.3	9.0	-
157	-	-	-	-	-	-	-	20.1	15.9	14.7	14.1	12.8	10.3	8.8	-
164	-	-	-	-	-	-	-	18.9	15.2	14.7	13.8	12.1	10.1	8.8	-
170	-	-	-	-	-	-	-	18.1	14.8	14.7	13.6	11.5	10.1	8.6	7.8
177	-	-	-	-	-	-	-	-	13.9	14.7	13.6	11.0	9.9	8.5	7.8
184	-	-	-	-	-	-	-	-	12.9	-	13.6	10.3	9.8	8.5	7.8
190	-	-	-	-	-	-	-	-	-	-	13.4	9.9	9.9	8.3	7.7
197	-	-	-	-	-	-	-	-	-	-	13.4	9.8	9.9	8.3	7.7
203	-	-	-	-	-	-	-	-	-	-	-	9.2	9.7	8.3	7.5
210	-	-	-	-	-	-	-	-	-	-	-	9.0	9.7	8.3	7.4
216	-	-	-	-	-	-	-	-	-	-	-	8.8	9.7	8.3	7.2
223	-	-	-	-	-	-	-	-	-	-	-	-	-	8.3	7.0
229	-	-	-	-	-	-	-	-	-	-	-	-	-	8.0	7.0
243	-	-	-	-	-	-	-	-	-	-	-	-	-	-	6.1

Remarks

- 1) Boom angle 82°
 - 2) plus 9.8 ft adapter
 - *) required weight of hook block + complementary weight on fly jib = 6,836 lb
 - ** required weight of hook block + complementary weight on fly jib = 9,308 lb
 - *** max. wind speed 19.3 mph
- Complementary weight and hook block are part of the load

Lifting capacities luffing fly jib, main boom 82° to 65°

Main boom: 127.9 ft²⁾

116,900 lb¹⁾ / 167,600 lb

 360°

75%

Radius ft	Fly jib														
	65.6 ft ²⁾			105.0 ft ^{**}			144.9 ft			177.1 ft			215.2 ft ^{***}		
	82°	73°	65°	82°	73°	65°	82°	73°	65°	82°	73°	65°	82°	73°	65°
	1 000 lb														
46	55.1	-	-	-	-	-	-	-	-	-	-	-	-	-	-
52	55.1	-	-	-	-	-	-	-	-	-	-	-	-	-	-
59	50.7	-	-	35.0	-	-	-	-	-	-	-	-	-	-	-
65	47.7	-	-	34.0	-	-	-	-	-	-	-	-	-	-	-
72	45.4	-	-	33.0	-	-	23.3	-	-	-	-	-	-	-	-
79	-	35.4	-	32.1	-	-	22.9	-	-	-	-	-	-	-	-
85	-	33.6	-	31.5	-	-	22.7	-	-	13.0	-	-	-	-	-
92	-	31.9	-	30.8	-	-	22.4	-	-	12.7	-	-	7.4	-	-
98	-	31.1	28.3	30.4	26.9	-	22.2	-	-	12.3	-	-	7.2	-	-
105	-	-	24.6	30.2	25.5	-	22.0	-	-	12.1	-	-	7.2	-	-
111	-	-	23.6	30.2	24.6	-	22.0	18.9	-	11.9	-	-	7.2	-	-
118	-	-	-	23.6	-	-	21.9	18.5	-	11.6	-	-	7.0	-	-
124	-	-	-	22.9	19.0	-	21.9	18.3	-	11.4	-	-	7.0	-	-
131	-	-	-	22.2	18.1	-	21.8	17.8	-	11.2	10.3	-	7.0	-	-
138	-	-	-	-	17.1	-	21.5	17.4	-	11.2	10.3	-	7.0	-	-
144	-	-	-	-	18.5	-	20.7	16.9	13.4	11.0	10.3	-	6.8	5.3	-
151	-	-	-	-	15.0	-	19.6	16.5	12.7	10.8	10.1	-	6.8	5.0	-
157	-	-	-	-	-	-	-	16.1	12.1	10.8	9.9	-	6.8	5.0	-
164	-	-	-	-	-	-	-	15.6	11.4	10.8	9.9	8.8	6.8	4.8	-
170	-	-	-	-	-	-	-	15.2	10.8	10.8	9.7	8.4	6.8	4.8	-
177	-	-	-	-	-	-	-	-	10.3	10.8	9.7	7.9	6.8	4.6	-
184	-	-	-	-	-	-	-	-	10.1	10.8	9.7	7.4	6.8	4.6	4.4
190	-	-	-	-	-	-	-	-	9.7	-	9.7	7.0	6.6	4.4	4.1
197	-	-	-	-	-	-	-	-	-	-	9.7	6.6	6.6	4.4	4.1
208	-	-	-	-	-	-	-	-	-	-	9.7	6.4	6.6	4.4	4.1
210	-	-	-	-	-	-	-	-	-	-	-	6.1	6.6	4.4	3.9
216	-	-	-	-	-	-	-	-	-	-	-	5.9	6.6	4.2	3.9
223	-	-	-	-	-	-	-	-	-	-	-	5.7	-	4.1	3.9
229	-	-	-	-	-	-	-	-	-	-	-	-	-	4.1	3.9
243	-	-	-	-	-	-	-	-	-	-	-	-	-	-	3.7
256	-	-	-	-	-	-	-	-	-	-	-	-	-	-	3.7

Remarks

- ¹⁾ Boom angle 82°
- ²⁾ plus 9.8 ft adapter
- * required weight of hook block + complementary weight on fly jib = 6,836 lb
- ** required weight of hook block + complementary weight on fly jib = 3,308 lb
- *** max. wind speed 13.3 mph

Lifting capacities luffing fly jib, main boom 82° to 65°

Main boom: 159.7 ft²⁾

116,900 lb¹⁾ / 167,600 lb



360°

75%

Radius	Fly jib														
	65.6 ft*			105.0 ft**			144.3 ft			179.1 ft			213.2 ft***		
	82°	73°	65°	82°	73°	65°	82°	73°	65°	82°	73°	65°	82°	73°	65°
ft	1,000 lb														
52	33.1	-	-	-	-	-	-	-	-	-	-	-	-	-	-
59	32.6	-	-	-	-	-	-	-	-	-	-	-	-	-	-
65	32.2	-	-	20.3	-	-	-	-	-	-	-	-	-	-	-
72	31.7	-	-	20.2	-	-	-	-	-	-	-	-	-	-	-
79	31.2	-	-	20.0	-	-	9.9	-	-	-	-	-	-	-	-
85	-	24.2	-	19.6	-	-	9.9	-	-	4.4	-	-	-	-	-
92	-	23.3	-	19.6	-	-	9.9	-	-	4.4	-	-	-	-	-
98	-	22.1	-	19.4	-	-	9.9	-	-	4.4	-	-	-	-	-
105	-	21.1	-	19.4	16.7	-	9.9	-	-	4.4	-	-	-	-	-
111	-	-	-	19.1	16.5	-	9.9	-	-	4.4	-	-	-	-	-
118	-	-	15.4	19.1	16.1	-	9.9	-	-	4.4	-	-	-	-	-
124	-	-	14.5	-	15.8	-	9.9	7.2	-	4.4	-	-	-	-	-
131	-	-	-	-	15.4	-	9.9	7.2	-	4.4	-	-	-	-	-
138	-	-	-	-	14.9	-	9.9	7.2	-	4.4	-	-	-	-	-
144	-	-	-	-	14.6	10.3	9.9	7.0	-	4.4	-	-	-	-	-
151	-	-	-	-	-	9.9	9.9	7.0	-	4.4	-	-	-	-	-
157	-	-	-	-	-	9.5	9.9	7.0	-	4.4	-	-	-	-	-
164	-	-	-	-	-	9.2	-	7.0	5.9	4.4	-	-	-	-	-
170	-	-	-	-	-	-	-	6.8	5.5	4.4	-	-	-	-	-
177	-	-	-	-	-	-	-	6.8	5.0	4.4	-	-	-	-	-
184	-	-	-	-	-	-	-	6.8	4.8	4.4	-	-	-	-	-
190	-	-	-	-	-	-	-	-	4.6	-	-	-	-	-	-
197	-	-	-	-	-	-	-	-	4.4	-	-	-	-	-	-
203	-	-	-	-	-	-	-	-	4.2	-	-	-	-	-	-

Main boom: 175.8 ft²⁾

116,900 lb¹⁾ / 167,600 lb



360°

75%

Radius	Fly jib														
	65.6 ft*			105.0 ft**			144.3 ft			179.1 ft			213.2 ft***		
	82°	73°	65°	82°	73°	65°	82°	73°	65°	82°	73°	65°	82°	73°	65°
ft	1,000 lb														
52	22.0	-	-	-	-	-	-	-	-	-	-	-	-	-	-
59	22.0	-	-	-	-	-	-	-	-	-	-	-	-	-	-
65	22.0	-	-	12.1	-	-	-	-	-	-	-	-	-	-	-
72	22.0	-	-	12.1	-	-	4.8	-	-	-	-	-	-	-	-
79	22.0	-	-	12.1	-	-	4.8	-	-	-	-	-	-	-	-
85	-	-	-	12.1	-	-	4.8	-	-	-	-	-	-	-	-
92	-	18.7	-	12.1	-	-	4.8	-	-	-	-	-	-	-	-
98	-	18.3	-	12.1	-	-	4.8	-	-	-	-	-	-	-	-
105	-	17.6	-	12.1	-	-	4.8	-	-	-	-	-	-	-	-
111	-	17.4	-	12.1	1.0	-	4.8	-	-	-	-	-	-	-	-
118	-	-	-	12.1	1.0	-	4.8	-	-	-	-	-	-	-	-
124	-	-	11.9	-	10.8	-	4.8	-	-	-	-	-	-	-	-
131	-	-	11.2	-	10.8	-	4.8	3.9	-	-	-	-	-	-	-
138	-	-	-	-	10.6	-	4.8	3.9	-	-	-	-	-	-	-
144	-	-	-	-	10.6	-	4.8	3.7	-	-	-	-	-	-	-
151	-	-	-	-	10.5	7.7	4.8	3.7	-	-	-	-	-	-	-
157	-	-	-	-	-	7.3	4.8	3.7	-	-	-	-	-	-	-
164	-	-	-	-	-	6.8	-	3.7	-	-	-	-	-	-	-
170	-	-	-	-	-	6.6	-	3.7	-	-	-	-	-	-	-
177	-	-	-	-	-	-	-	3.5	-	-	-	-	-	-	-
184	-	-	-	-	-	-	-	3.5	-	-	-	-	-	-	-

Remarks

- ¹⁾ Boom angle 82° ²⁾ plus 9.8 ft adapter
- * required weight of hook block – complementary weight on fly jib = 6,896 lb
- ** required weight of hook block – complementary weight on fly jib = 3,908 lb
- *** max. wind speed 13.0 mph

Technical description

Carrier

Drive/Steering:	12 x 6 x 8.
Frame:	Demag-built monobox main frame with outrigger boxes integral of high strength fine grain structural steel.
Outriggers:	4-point outrigger system, fully hydraulic horizontal and vertical extension.
Engine:	Daimler-Benz OM 442 LA water-cooled 8-cylinder diesel engine, rating: 405 kW (550 hp) at 2100 rpm, torque 2360 Nm at 1100 rpm, fuel tank capacity 174 gallons.
Transmission:	ZF-Transmatik transmission with converter and 16-speed synchromesh gearbox (16 speeds forward and 2 reverse), flanged-on transfer case with differential lockout control.
Axles:	Axles 2, 5 and 8 driven; 1, 2, 5 and 6 steering. Differential lockout control: axles 2, 5 and 6 with transverse lockout control, 5th axle with longitudinal lockout control.
Suspension:	Hydropneumatic suspension on all axles, all axles hydraulically lockable.
Wheels and tires:	12 disk-type wheels 11.0 - 25/1,7 fitted with 18.00 R 25 tires.
Steering:	Dual-circuit semi-link mechanics, steering with hydraulic booster.
Brakes:	to EC directives.
Electrical equipment:	24 V system.
Driver's cab:	Rubber mounted all steel low-line cab, driver and passenger seats, full instrumentation and carrier controls.

Superstructure

Engine:	Daimler-Benz OM 366 LA water-cooled 6-cylinder diesel engine, rating: 143 kW (194 hp) at 2200 rpm, torque 646 Nm at 1400 rpm, fuel tank capacity 74 gallons.
Hydraulic system:	Two variable displacement axial-piston pumps with automatic power control and one fixed-displacement pump to provide three hydraulic working circuits and three simultaneous working movements, one fixed-displacement pump for the low pressure servo control.
Hoist:	Variable-displacement axial-piston hydraulic motor, hoist drum with integral planetary gear reducer and brake.
Slew unit:	Axial-piston hydraulic motor with planetary gear reducer, foot-pedal operated brake and spring-applied holding brake.
Boom elevation:	One differential cylinder with pilot-controlled lowering brake valve.
Control:	Electric pilot control by two 4-way solenoid-actuated hand levers.
Crane cab:	Spacious all-steel comfortable cab with sliding door and large hinged window, roof window of armored glass, full instrumentation and crane controls, comfortable operator's seat with ergonomic armrest mounted joystick controls, working light. Self-contained and engine-dependent hot water heater with argine preheating and 7-day programmable timer, thermostat-controlled, intermittent control windshield wiper and washer.
Outrigger loading indicator:	Indication of outrigger loading in the upper cabin.
Main boom:	Boom base and four telescopic sections, fabricated from fine grain structural steel, hydraulically telescoping to full boom length. Buckling-resistant Demag ovaloid design with diagonal self-centering slider shoes, boom head incl. parts to fit the optional jibs and fold-away extension, boom sections pinned hydraulically.
Counterweight:	116,000 lb, in sections of 12,800 lb and 7,300 lb and 4 x 24,300 lb.
Safety devices:	Electronic safe load indicator with easy-to-read graphic display and sealed touch-type keyboard, and digital read-out for hook load, nominal load, radius, boom length and angle. Analog display to indicate capacity utilization and monitoring code to assist in trouble shooting. Integrated read-out for boom telescoping, display for duty charts and theoretical outrigger loading. In addition, the following safety devices have been installed: limit switches on hoist and lowering motions, pressure relief and safety holding valves, hoist rotation indicator and windmeter.

Optional equipment

Drive:	12 x 6, 3rd axle driven in addition.
Carrier engine:	Cummins N14, 6 cylinder diesel engine; rating: 500-hp at 1800 rpm; torque 1750 ft-lb at 1200 rpm; fuel tank capacity 174 gallons.
Superstructure engine:	Cummins 6BTA, 6-cylinder diesel engine; rating: 200-hp at 2200 rpm; torque 593 ft-lb at 1500 rpm; fuel tank capacity 74 gallons.
Tires:	20.5 R 25 tires.
Electric retarder:	As optional retarder.
Night heater:	Self-contained hot water heater for carrier cab.
Bunk bed:	Carrier cab with bunk bed.
Independent rear axle steering (crab steer):	The rear axles can be steered independent of the front axles. 3rd and 4th axles are raised hydraulically.
Superlift attachment:	This attachment is used to increase the crane's load moment. It consists of the boom suspension system and a 106,000 lb additional counterweight. The boom suspension provides for an automatic rope length adjustment for boom telescoping and is lowered to the main boom when not needed or for road transport. The rear suspension consists of bars, which fold automatically into transport position when lowered to the boom.
Main boom extension:	35.1 ft, side folding lattice structure 0° and 20° offset.
Luffing fly jib:	65.6 - 213.2 ft. with luffing mast and 9.8 ft adapter, pendant bars, electrical equipment and safety devices (the 2nd hoist drum is required when using the luffing fly jib).
Fixed fly jib:	65.6 - 134.5 ft. consisting of components taken from the luffing jib. Offset with 65.6 - 134.5 ft jib: 9° and 20°.
Additional counterweight:	106,000 lb, comprising of four sections, installed by the crane itself.
Hoist II:	Avoids re-reaving of hoist line when using the optional fly jibs. It is indispensable for fly jib luffing. Powered by variable displacement axial piston motor, hoist drum with integral planetary gear reducer and brake not ropes.
Heavy-lift attachment I:	Additional sheaves on main boom head.
Heavy-lift attachment II:	Central jack leg.