

Hydraulic Crawler Crane

7120S

Model : 7120S

Max. Lifting Capacity: **120 t x 5.0 m**

Max. Lifting Capacity With Tower Jib: **20.0 t x 15.0 m**

Max. Crane Boom Length: **61.0 m**

Max. Long Boom Length: **79.2 m**

Max. Fixed Jib Combination: **61.0 m + 30.5 m**

Max. Tower Jib Combination: **51.7 m + 44.2 m**

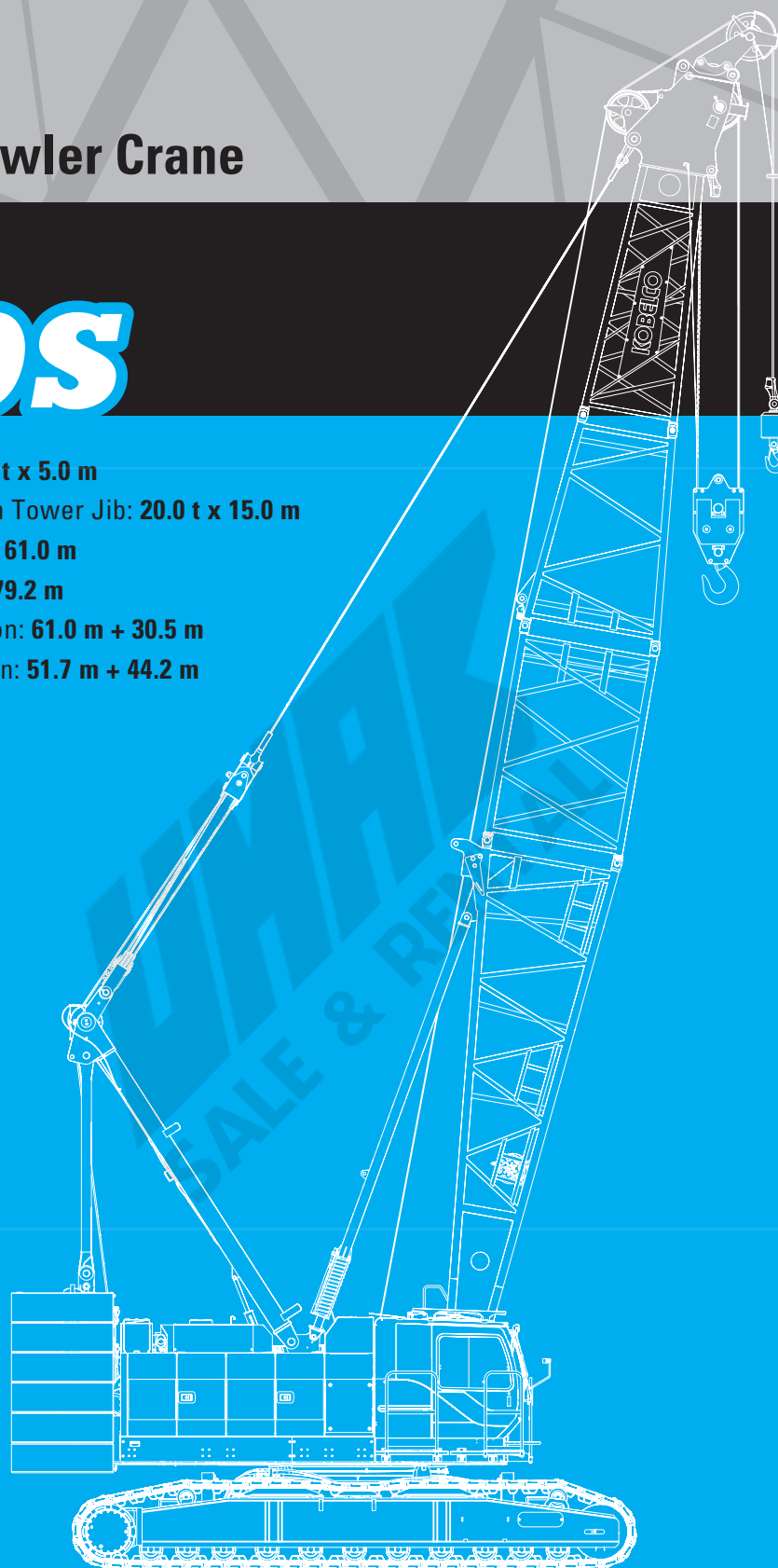

KOBELCO

UMAX
SALE & RENTAL

7120S

CONTENTS

3	SPECIFICATIONS
5	GENERAL DIMENSIONS
7	BOOM AND JIB ARRANGEMENTS
10	WORKING RANGES
15	SUPPLEMENTAL DATA
16	LIFTING CAPACITIES
24	SUPPLEMENTAL DATA
25	LIFTING CAPACITIES
31	GENERAL DIMENSION FOR CLAMSHELL
32	WORKING RANGE FOR CLAMSHELL
33	SUPPLEMENTAL DATA FOR CLAMSHELL
34	LIFTING CAPACITIES FOR CLAMSHELL
35	SUPPLEMENTAL DATA FOR REDUCED WEIGHTS
36	LIFTING CAPACITIES FOR REDUCED WEIGHTS
37	SUPPLEMENTAL DATA FOR BARGE
38	LIFTING CAPACITIES FOR BARGE
39	TRANSPORTATION PLAN
43	PARTS AND ATTACHMENTS

SPECIFICATIONS



Power Plant

Model: HINO P11C-VH

Type: 4 cycle, water-cooled, vertical in-line 6, direct injection, turbo-charger, intercooler

Displacement: 10,520 liters

Rated power: 271 kW/1,850 min⁻¹

Max. Torque: 1,469 N·m/1,400 min⁻¹

Cooling System: Water-cooled

Starter: 24V-6kW

Radiator: Corrugated type core, thermostatically controlled

Air cleaner: Dry type with replaceable paper element

Throttle: Twist grip type hand throttle, electrically actuated

Fuel filter: Replaceable paper element

Batteries: Two 12 V x 136 Ah/5HR capacity batteries, series connected

Fuel tank capacity: 400 liters



Hydraulic System

Main pumps: 4 variable displacement piston pumps

Control: Full-flow hydraulic control system for infinitely variable pressure to all winches, propel and swing. Controls respond instantly to the touch, delivering smooth function operation.

Cooling: Oil-to-air heat exchanger (plate-fin type)

Filtration: Full-flow and bypass type with replaceable element

Max. relief valve pressure:

Load hoist, boom hoist and propel system: 31.9 MPa

Swing system: 27.5 MPa

Control system: 5.4 MPa

Hydraulic Tank Capacity: 535 liters



Boom Hoisting System

Powered by a hydraulic motor through a planetary reducer.

Brake: A spring-set, hydraulically released multiple-disc brake is mounted on the boom hoist motor and operated through a counter-balance valve.

Drum Lock: External ratchet for locking drum

Drum: Single drum, grooved for 20 mm dia. wire rope

Line Speed: Single line on first drum layer

Hoisting/Lowering: 48 to 2 m/min

Boom hoisting/lowering: 20 mm x 190 m

Boom guy line: 30 mm

Boom backstops: Required for all boom length



Load Hoisting System

Front and rear drums for load hoist powered by a hydraulic variable plunger motors, driven through planetary reducers.

Negative Brake: A spring-set, hydraulically released multiple-disc brake is mounted on the hoist motor and operated through a counter-balance valve. (Positive free fall brake is optional)

Drum Lock: External ratchet for locking drum

Drums:

Front Drums:

666 mm P.C.D x 672 mm wide drum, grooved for 26 mm wire rope. Rope capacity is 275 m working length and 350 m storage length.

Rear Drum: 666 mm P.C.D x 672 mm, grooved for 26 mm wire rope. Rope capacity is 255 m working length and 350 m storage length.

Diameter of wire rope

Main winch: 26 mm x 275 m

Aux. winch: 26 mm x 255 m

Third winch: 26 mm x 240 m

Line Speed*:

Hoisting/lowering: 120 to 3 m/min

Line Pull:

Max. Line Pull*: 233 kN {23.8 tf}
(Referential performance)

Rated Line Pull: 118 kN {12.0 tf}

*Single line on first drum layer



Swing System

Swing unit is powered by hydraulic motor driving spur gears through planetary reducer, the swing system provides 360° rotation.

Swing parking brakes: A spring-set, hydraulically released multiple-disc brake is mounted on swing motor.

Swing circle: Single-row ball bearing with an integral internally cut swing gear.

Swing lock: Manually, four position lock for transportation

Swing Speed: 2.1 min⁻¹



Upper Structure

Torsion-free precision machined upper frame. All components are located clearly and service friendly. Engine will with low noise level.

Counterweight: 53.1 ton



Cab & Control

Totally enclosed, full vision cab with safety glass, fully adjustable, high backed seat with a headrest and armrests, and intermittent wiper and window washer (skylight and front window).

Cab fittings:

Air conditioner, convenient compartment (for tool), cup holder, cigarette lighter, sun visor, roof blind, tinted glass, floor mat, footrest, and shoe tray

**Lower Structure**

Steel-welded carbody with axles. Crawler assemblies are designed with quick disconnect feature for individual removal as a unit from axles. Crawler belt tension is maintained by hydraulic jack force on the track adjusting bearing block.

Crawler drive: Independent hydraulic propel drive is built into each crawler side frame. Each drive consists of a hydraulic motor propelling a driving tumbler through a planetary gear box. Hydraulic motor and gear box are built into the crawler side frame within the shoe width.

Crawler brakes: Spring-set, hydraulically released parking brakes are built into each propel drive.

Steering mechanism: A hydraulic propel system provides both skid steering (driving one track only) and counter-rotating steering (driving each track in opposite directions).

Track rollers: Sealed track rollers for maintenance-free operation.

Shoe (flat): 910 mm wide each crawler

Max. gradeability: 30%

**Weight**

Including upper and lower machine, 53.1 ton counterweight and basic boom (or basic boom + basic jib), hook, and other accessories.

Weight: 120 ton

Ground pressure: 93.6 kPa

**Attachment****Boom & Jib:**

Welded lattice construction using tubular, high-tensile steel chords with pin connection between sections.

Boom and Jib length

	Min. Length (Min. combination)	Max. Length (Max. combination)
Crane Boom	15.2 m	61.0 m
Fixed Jib	24.4 m + 12.2 m	61.0 m + 30.5 m

Main Specifications (Model: 7120S)

Crane Boom	
Max. Lifting Capacity	120 t x 5.0 m
Max. Length	61.0 m
Fixed Jib	
Max. Lifting Capacity	12.0 t x 28.0 m
Max. Combination	61.0 m + 30.5 m
Long Boom	
Max. Lifting Capacity	24.0 t x 16.0 m
Max. Length	79.2 m
Tower Jib	
Max. Lifting Capacity	20.0 t x 15.0 m
Max. Jib Length	44.2 m
Max. Combination	51.7 m + 44.2 m
Main & Aux. Winch	
Max. Line Speed (1st layer)	120 m/min
Rated Line Pull (Single line)	118 kN {12.0 tf}
Wire Rope Diameter	26 mm
Wire Rope Length	275m (Main), 255 m (Aux.)
Brake Type (Free fall)	Wet-type multiple disc brake (Optional)
Working Speed	
Swing Speed	2.1 min ⁻¹ {rpm}
Travel Speed	1.3/0.9 km/h

Power Plant	
Model	HINO P11C-VH
Engine Output	271 kW/1,850 min ⁻¹
Fuel Tank	400 liters
Hydraulic System	
Main Pumps	4 variable displacement
Max. Pressure	31.9 MPa {325 kgf/cm ² }
Hydraulic Tank Capacity	535 liters
Self-Removal Device	
	NA
Weight	
Operating Weight	120 t *1
Ground Pressure	93.6 kPa
Counterweight	53,110 kg
Transport Weight	34,800 kg *2

Units are SI units. { } indicates conventional units.

Line speeds in table are for light loads. Line speed varies with load.

*1 Including upper and lower machine, 53.1 ton counterweight, basic boom, hook, and other accessories.

*2 Base Machine with boom base gantry, wire ropes (front/rear/boom hoist)

GENERAL DIMENSIONS

(Unit: mm)

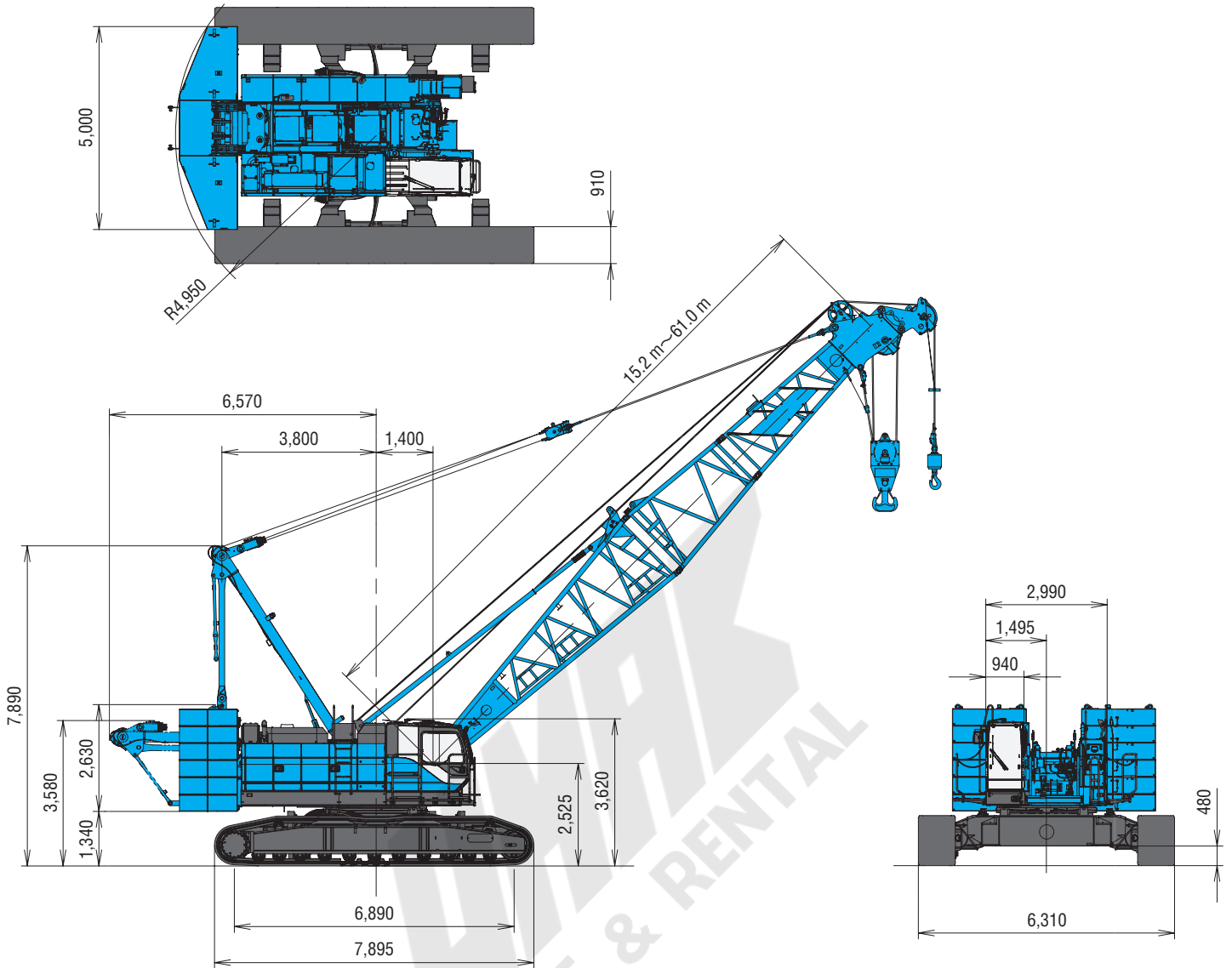

Limit of Hook Lifting

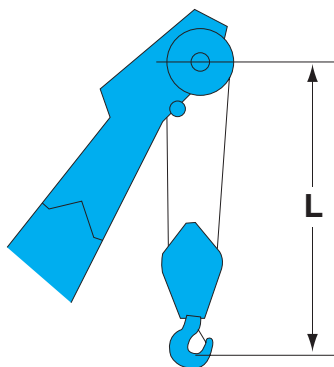

Hook	L
120 t hook	5.0 m
70 t hook	5.0 m
35 t hook	5.0 m

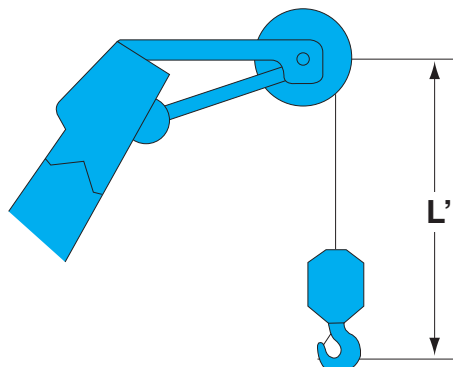

Hook	L'
Ball hook	4.2 m

Tower Jib

(Unit: mm)

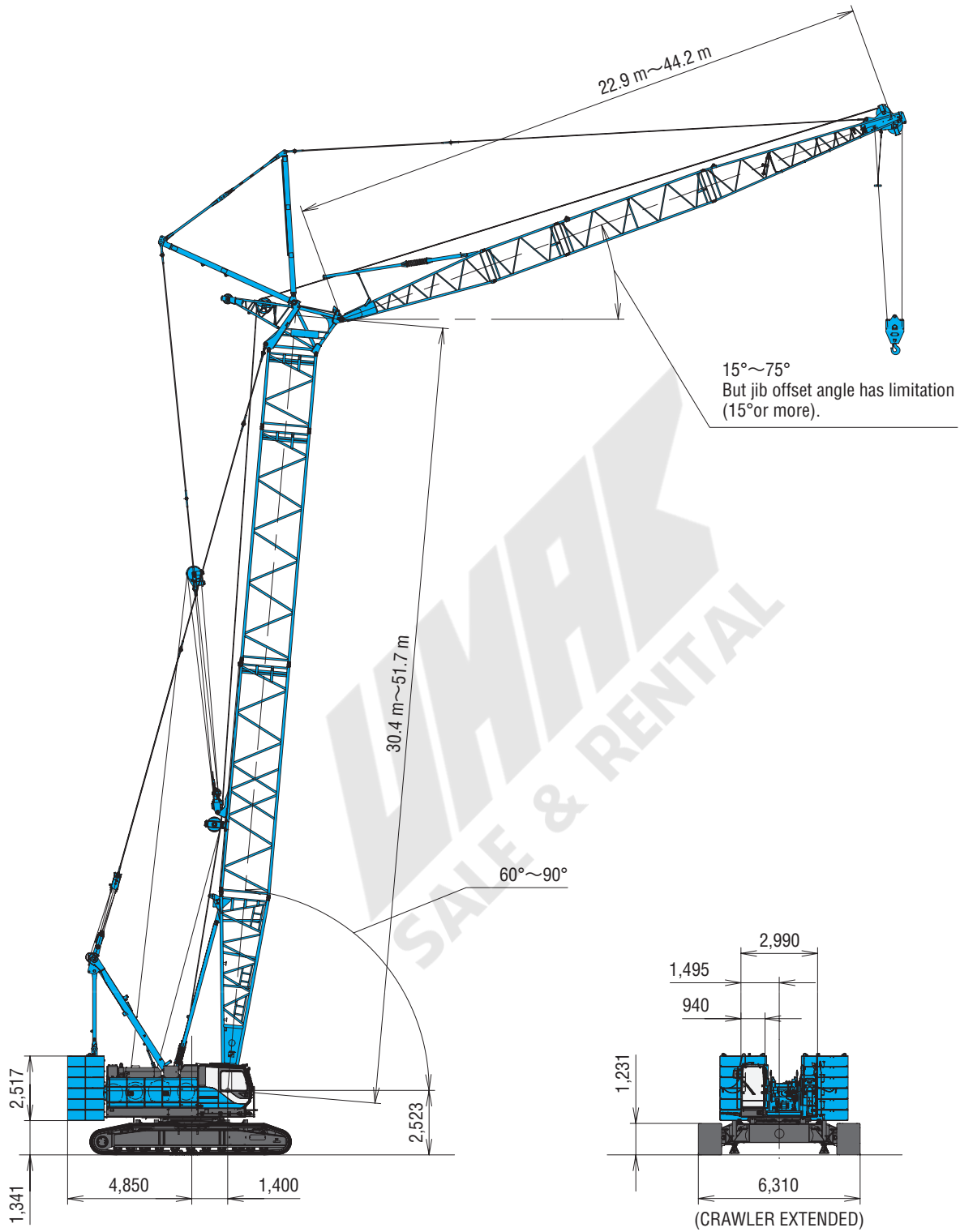

This catalog may contain photographs of machines with specifications, attachments and optional equipment.

BOOM AND JIB ARRANGEMENTS

Crane Boom Arrangements

Boom length m (ft)	Boom arrangement
15.2 (50)	
18.3 (60)	
21.3 (70)	
24.4 (80)	
27.4 (90)	
30.5 (100)	
33.5 (110)	
36.6 (120)	
39.6 (130)	

Boom length m (ft)	Boom arrangement
42.7 (140)	
45.7 (150)	
48.8 (160)	
51.8 (170)	
54.9 (180)	
57.9 (190)	
61.0 (200)	

Symbol	Boom Length	Remarks
	7.6 m	Boom Base
	4.6 m	Boom Top
	3.0 m	Tapered Boom
	3.0 m	Insert Boom
	6.1 m	Insert Boom
	9.1 m	Insert Boom

↗ mark shows the guy line installing position when the fixed jib is used.

※ Indicates the most flexible combination of insert booms, which can be modified to form all shorter boom arrangements.

Long Boom Arrangements

Boom length m (ft)	Long Boom arrangement
61.0 (200)	
64.0 (210)	*
67.1 (220)	*
70.1 (230)	
73.2 (240)	*
76.2 (250)	
79.2 (260)	

Symbol	Long Boom Length	Remarks
	7.6 m	Boom Base
	7.6 m	Tower Jib Top
	3.0 m	Insert Boom
	6.1 m	Insert Boom
	9.1 m	Insert Boom
	3.0 m	Tapered Boom
	3.0 m	Relay Jib
	3.0 m	Tower Insert Jib
	6.1 m	Tower Insert Jib
	9.1 m	Tower Insert Jib

※ Indicates the most flexible combination of insert long booms, which can be modified to form all shorter long boom arrangements.

Fixed Jib Arrangements

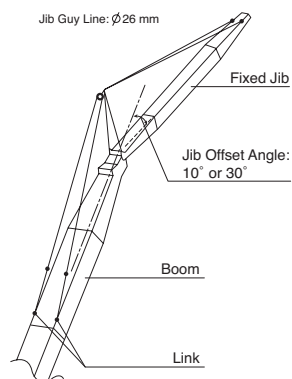

Crane boom length	Jib length m (ft)	Jib arrangement	Jib offset angle
24.4 m ~ 61.0 m	12.2 (40)		30°
	18.3 (60)		10°/30°
	24.4 (80)		10°/30°
	30.5 (100)		10°/30°





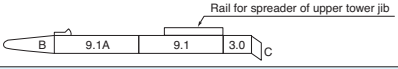
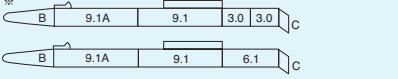
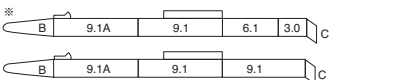
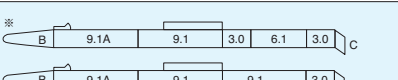
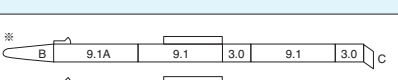
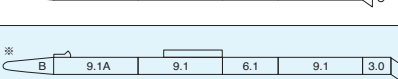
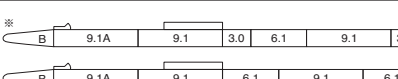
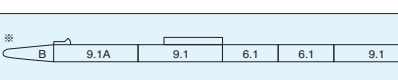

※ The jib length of 12.2 m is based on the only setting of 30 degrees offset.

Symbol	Jib Length	Remarks
	4.6 m	Jib Base
	4.6 m	Jib Top
	3.0 m	Insert Jib
	6.1 m	Insert Jib

BOOM AND JIB ARRANGEMENTS

Tower Arrangements



Tower length m (ft)	Tower arrangement
30.4 (100)	
33.4 (110)	
36.5 (120)	
39.5 (130)	
42.5 (140)	
45.6 (150)	
48.6 (160)	
51.7 (170)	

Symbol	Tower Length	Remarks
	7.6 m	Boom Base
	1.4 m	Tower Cap
	3.0 m	Insert Boom
	6.1 m	Insert Boom
	9.1 m	Insert Boom
	9.1 m	Special Insert Boom for Tower

※ Indicates the most flexible combination of insert tower booms, which can be modified to form all shorter tower boom arrangements.
9.1A should be basically used in tower, and it may be also used as insert boom for crane.

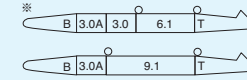
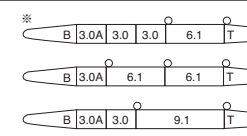
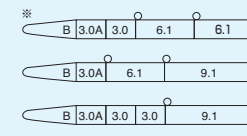
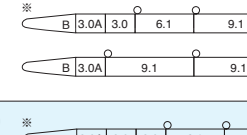
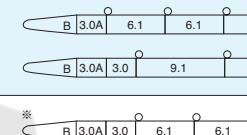
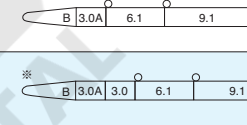
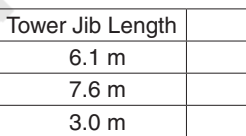
Tower Jib Arrangements

Jib length m (ft)	Jib arrangement
22.9 (75)	
25.9 (85)	
29.0 (95)	
32.0 (105)	
35.1 (115)	
38.1 (125)	
41.1 (135)	
44.2 (145)	

Symbol	Tower Jib Length	Remarks
	6.1 m	Tower Jib Base
	7.6 m	Tower Jib Top
	3.0 m	Relay Jib
	3.0 m	Tower Insert Jib
	6.1 m	Tower Insert Jib
	9.1 m	Tower Insert Jib

※ Indicates the most flexible combination of insert tower jibs, which can be modified to form all shorter tower jib arrangements.
○ mark indicates position where cable rollers attached

Tower and Jib Combinations and Allowable Tower Angle

Tower length \ Jib length		Tower length								
		22.9 m	25.9 m	29.0 m	32.0 m	35.1 m	38.1 m	41.1 m	44.2 m	Pillow plate
30.4 m	90°-60°	90°-60°	—	—	—	—	—	—	—	—
33.4 m	90°-60°	90°-60°	90°-60°	90°-60°	—	—	—	—	—	—
36.5 m	90°-60°	90°-60°	90°-60°	90°-60°	—	—	—	—	—	—
39.5 m	90°-60°	90°-60°	90°-60°	90°-60°	90°-60°	—	—	—	—	—
42.5 m	90°-60°	90°-60°	90°-60°	90°-60°	90°-60°	90°-60°	—	—	—	—
45.6 m	90°-60°	90°-60°	90°-60°	90°-60°	90°-60°	90°-60°	90°-70°	—	—	—
48.6 m	90°-60°	90°-60°	90°-60°	90°-60°	90°-60°	90°-70°	90°-70°	90°-70°	—	—
51.7 m	90°-60°	90°-60°	90°-60°	90°-60°	90°-70°	90°-70°	90°-70°	90°-70°	—	Need
Hook	35 ton hook	○	○	○	○	○	○	○	○	⊗
	Ball hook	×	○	○	○	○	○	○	○	

○ : Available
⊗ : Not available

WORKING RANGES

Crane Boom

Unit : m

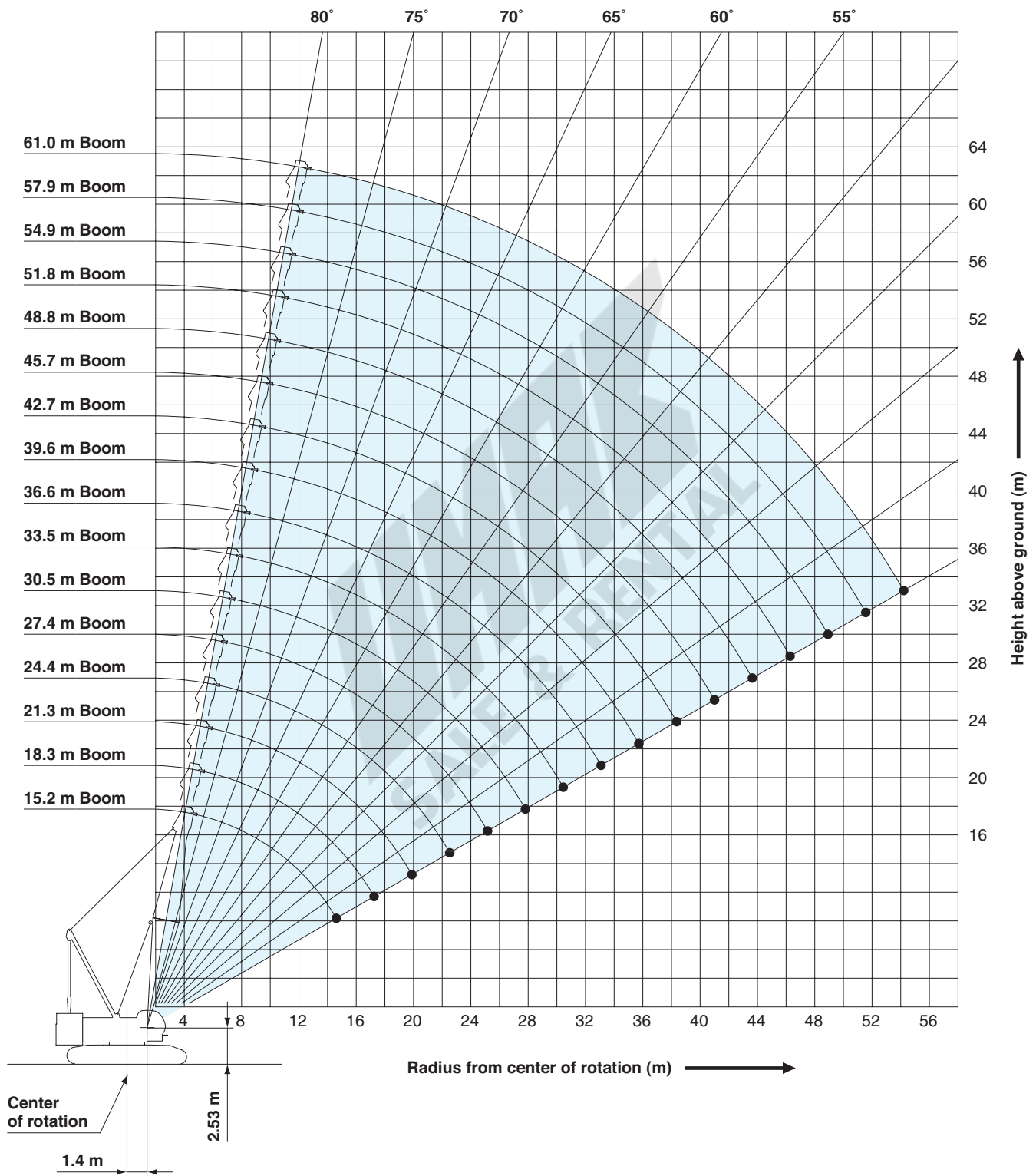

WORKING RANGES

Fixed Jib 10°, 30°

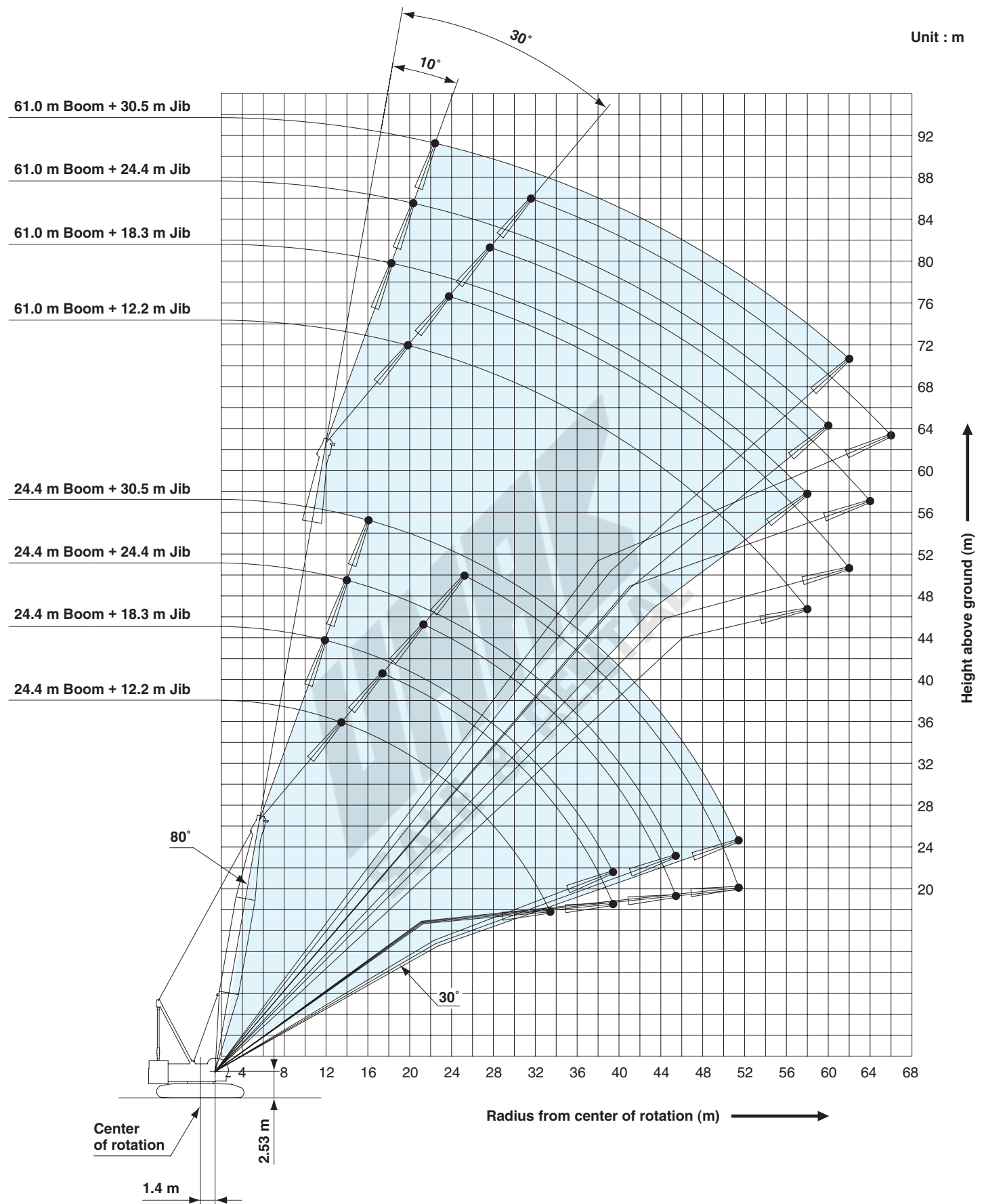

Long Boom

Unit : m

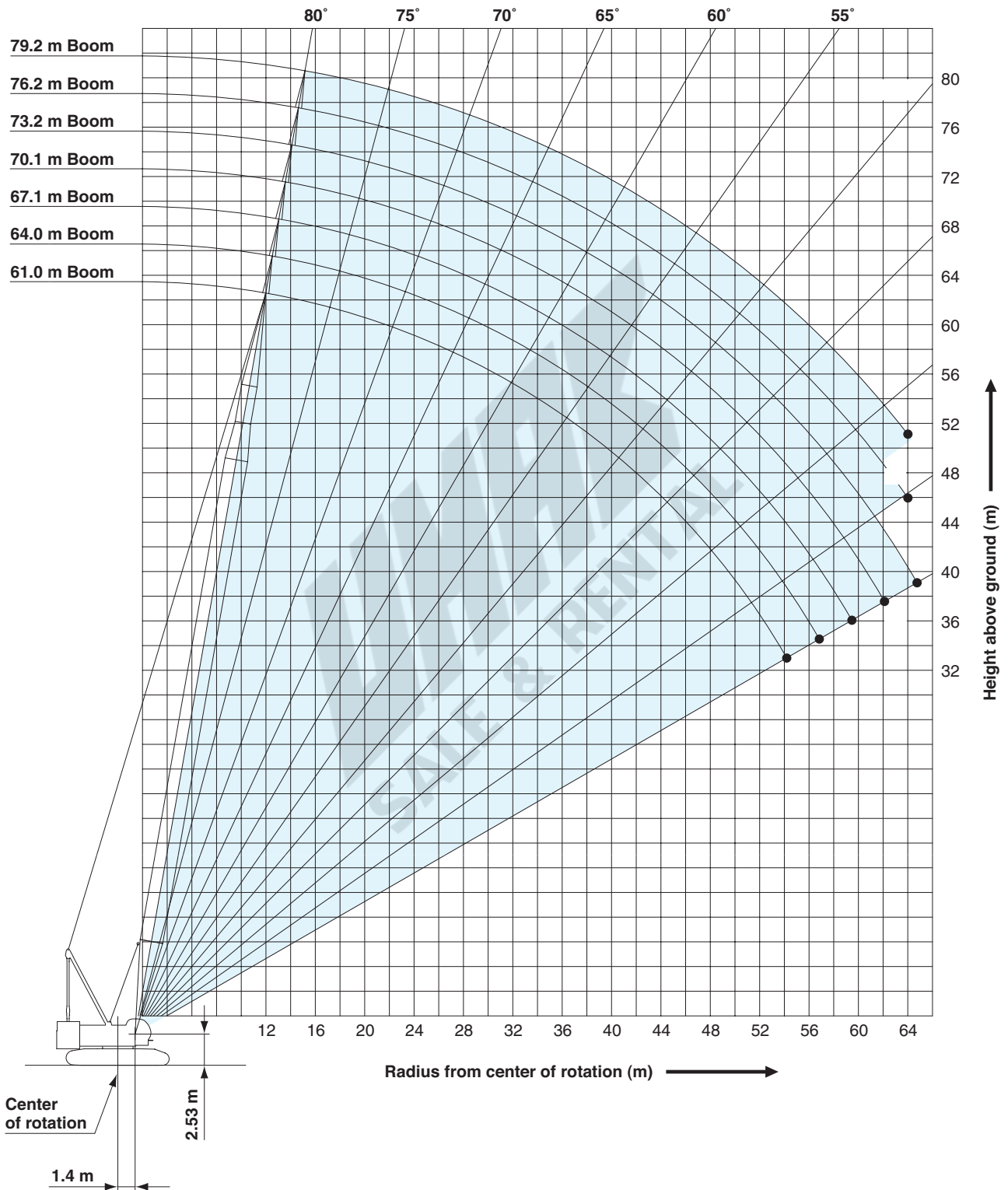

WORKING RANGES

Tower Jib

Tower Length: 39.5 m

Unit : m

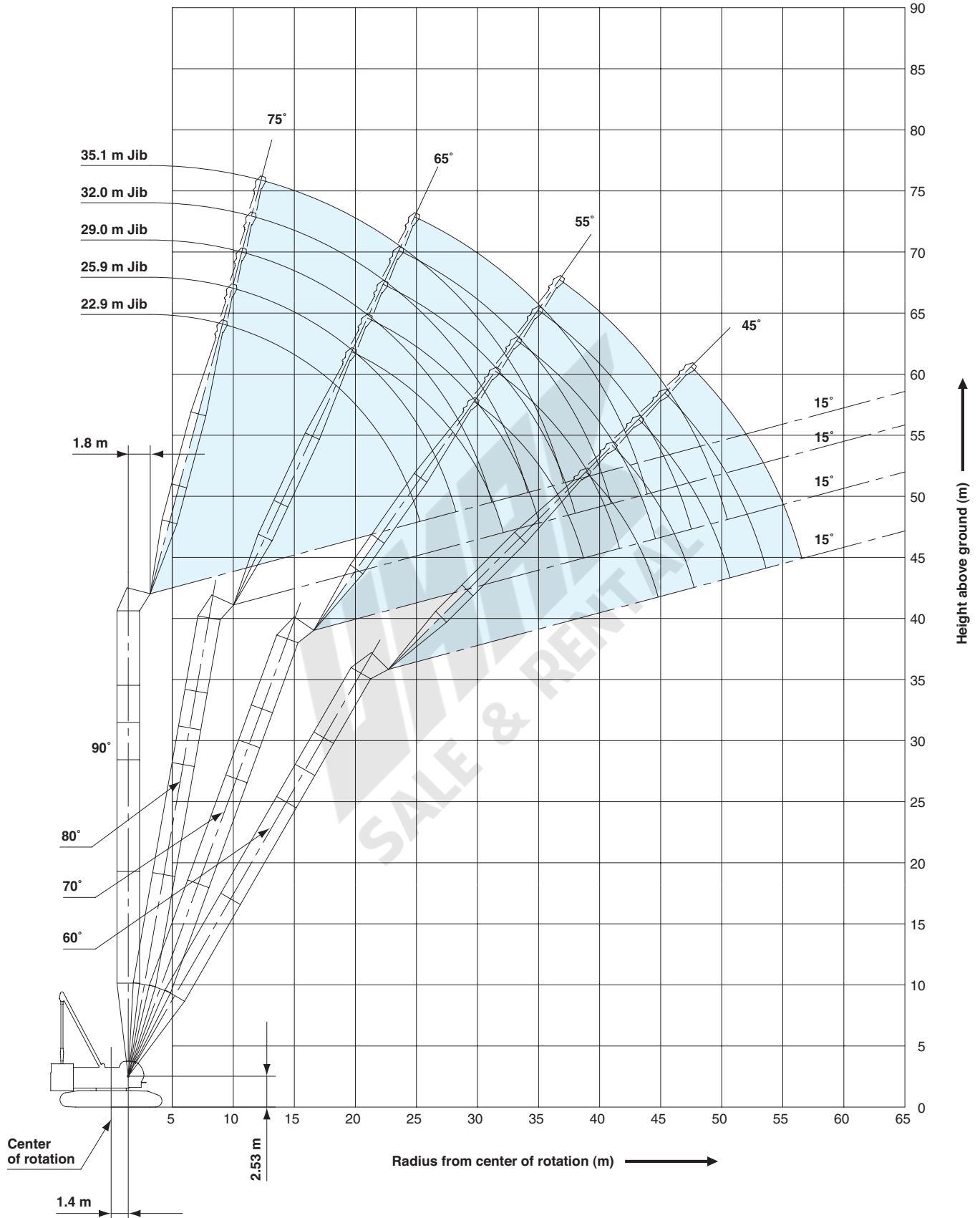

Tower Jib

Tower Length: 51.7 m

Unit : m

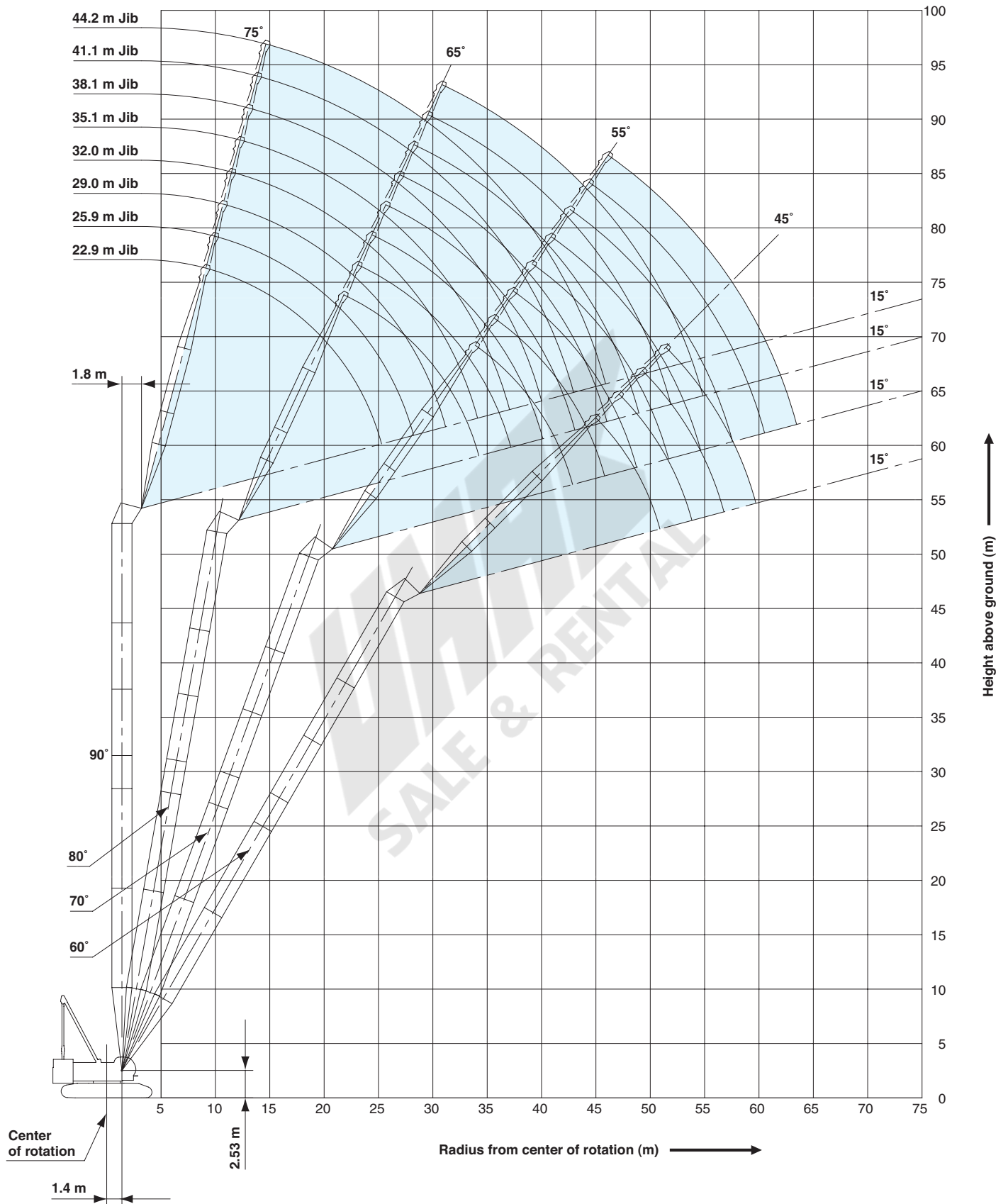

- Ratings according to Japanese Construction Codes for Mobile Cranes.
- Operating radius is the horizontal distance from centerline of rotation to a vertical line through the center of gravity of the load.
- Deduct weight of hook block (s), slings and all other load handling accessories from main boom ratings shown.
- Ratings shown are based on freely suspended loads and make no allowance for such factors as wind effect on lifted load, ground conditions, out-of-level, operating speeds or any other condition that could be detrimental to the safe operation of this equipment. The operator, therefore, has the responsibility to judge the existing conditions and reduce lifted loads and operating speeds accordingly.
- Ratings are for operation on a firm and level surface, up to 1% gradient.
- At radii and boom lengths where no ratings are shown on chart, operation is not intended nor approved.
- Boom inserts and guy lines must be arranged as shown in the "Operator's Manual".
- Boom hoist reeving is 12 part line.
- Gantry must be in raised position for all conditions.
- Boom backstops are required for all boom lengths.
- The boom should be erected over the front of the crawlers, not laterally.
- Ratings inside of boxes are limited by strength of materials.
- The minimum rated load is 2.0 (ton).

(Crane boom/long boom lifting)

- The total load that can be lifted is the value for weight of hook block, slings, and all other load handling accessories deducted from main boom ratings shown.

<Reference Information>

Main hoist loads

No. of Parts of Line	1	2	3	4	5
Maximum Loads (kN)	118	235	353	471	588
Maximum Loads (t)	12.0	24.0	36.0	48.0	60.0

No. of Parts of Line	6	7	8	9	10
Maximum Loads (kN)	706	824	941	1,059	1,177
Maximum Loads (t)	72.0	84.0	96.0	108.0	120.0

Auxiliary hoist loads

No. of Parts of Line	1
Maximum Loads (kN)	118
Maximum Loads (t)	12.0

Weight of hook block				
Hook Block	120 t	70 t	35 t	Ball Hook
Weight (t)	1.7	1.2	0.9	0.45

(Fixed jib lifting)

- The total load that can be lifted is the value for weight of jib hook block, slings, and all other load handling accessories deducted from fixed jib ratings shown.
- The availability of fixed jib mounting
 - on crane boom : range 24.4 m to 61.0 m.
- One part of line on hook is not allowed to use for 12.2 m jib length with offset angle 10 degrees.

Operation of this equipment in excess of rated loads or disregard of instruction voids the warranty.
--

LIFTING CAPACITIES



Crane Boom Lifting Capacities

Counterweight: 53.1 t

Unit: metric ton

Working radius (m)	Boom length (m)	15.2	18.3	21.3	24.4	27.4	30.5	33.5	36.6	Boom length (m)	Working radius (m)
	4.5	4.5m/120.0									
5.0	120.0	5.1m/108.0	5.6m/96.0								5.0
6.0	100.0	99.8	94.9	6.1m/84.0	6.7m/74.6						6.0
7.0	85.7	85.5	85.3	81.5	73.7	7.2m/66.4	7.7m/59.4				7.0
8.0	73.7	73.6	73.5	73.5	71.3	64.7	58.9	8.2m/53.6			8.0
9.0	61.5	61.3	61.2	61.1	61.0	60.9	57.2	52.5			9.0
10.0	52.6	52.5	52.3	52.2	52.1	52.0	52.0	51.2			10.0
12.0	40.6	40.5	40.3	40.2	40.0	40.0	39.9	39.7			12.0
14.0	33.0	32.8	32.6	32.5	32.3	32.3	32.2	32.0			14.0
16.0	14.9m/29.1	27.5	27.3	27.2	26.9	26.9	26.8	26.6			16.0
18.0		17.5m/24.5	23.3	23.2	23.0	22.9	22.8	22.6			18.0
20.0			20.3	20.2	20.0	19.9	19.8	19.5			20.0
22.0			20.1m/20.2	17.8	17.6	17.5	17.4	17.1			22.0
24.0				22.8m/17.1	15.6	15.5	15.4	15.2			24.0
26.0					25.4m/14.5	13.9	13.8	13.6			26.0
28.0						12.6	12.5	12.2			28.0
30.0							11.3	11.1			30.0
32.0							30.7m/11.0	10.1			32.0
34.0								33.3m/9.5			34.0
Reeves		10	9	8	7	7	6	5	5		Reeves

Working radius (m)	Boom length (m)	39.6	42.7	45.7	48.8	51.8	54.9	57.9	61.0	Boom length (m)	Working radius (m)
	8.0	8.8m/48.0									
9.0	48.0	9.3m/43.5	9.8m/39.6								9.0
10.0	46.8	42.8	39.5	10.4m/36.0	10.9m/32.1	11.4m/29.4					10.0
12.0	39.7	39.5	37.8	34.7	31.4	29.0	26.9	12.5m/24.0			12.0
14.0	31.9	31.8	31.6	31.6	30.1	27.9	25.9	23.5			14.0
16.0	26.5	26.4	26.2	26.1	26.0	25.8	24.9	22.8			16.0
18.0	22.5	22.4	22.2	22.1	22.0	21.8	21.6	21.4			18.0
20.0	19.5	19.3	19.1	19.1	18.9	18.7	18.6	18.5			20.0
22.0	17.1	16.9	16.7	16.6	16.5	16.3	16.1	16.0			22.0
24.0	15.1	14.9	14.7	14.7	14.5	14.3	14.1	14.1			24.0
26.0	13.5	13.3	13.1	13.0	12.9	12.7	12.5	12.4			26.0
28.0	12.1	12.0	11.7	11.7	11.5	11.3	11.1	11.0			28.0
30.0	11.0	10.8	10.6	10.5	10.3	10.1	10.0	9.9			30.0
32.0	10.0	9.8	9.6	9.5	9.3	9.1	9.0	8.9			32.0
34.0	9.1	8.9	8.7	8.6	8.5	8.2	8.1	8.0			34.0
36.0	8.4	8.2	8.0	7.9	7.7	7.5	7.3	7.2			36.0
38.0		7.5	7.3	7.2	7.0	6.8	6.6	6.5			38.0
40.0		38.6m/7.4	6.7	6.6	6.4	6.2	6.0	5.9			40.0
42.0			41.2m/6.4	6.1	5.9	5.7	5.5	5.4			42.0
44.0				43.9m/5.6	5.4	5.2	5.0	4.9			44.0
46.0					5.0	4.7	4.6	4.4			46.0
48.0					46.5m/4.9	4.3	4.1	3.9			48.0
50.0						49.2m/4.1	3.7	3.5			50.0
52.0							51.8m/3.3	3.1			52.0
54.0								2.7			54.0
56.0								54.4m/2.7			56.0
Reeves		4	4	4	3	3	3	3	2		Reeves

Note:

Ratings according to Japanese Construction Codes for Mobile Cranes and Japanese Safety Ordinance on Cranes, etc.

Ratings shown in are determined by the strength of the boom or other structural components.

Lifting capacities may vary depending on hook used or with/without auxiliary sheave.

Please refer rated chart in operator's cabin.

LIFTING CAPACITIES



Fixed Jib Lifting Capacities (Without Main Hook Block) (Jib Offset Angle : 10°)

Counterweight: 53.1 t

Unit: metric ton

Boom length (m)	24.4				27.4				30.5				Boom length (m)
Jib length (m)	12.2	18.3	24.4	30.5	12.2	18.3	24.4	30.5	12.2	18.3	24.4	30.5	Jib length (m)
10.0	10.2m/12.0				10.7m/12.0				11.2m/12.0				10.0
12.0	12.0	12.2m/12.0			12.0	12.8m/12.0			12.0	13.3m/12.0			12.0
14.0	12.0	12.0	14.3m/8.0		12.0	12.0	14.9m/8.0		12.0	12.0	15.4m/8.0		14.0
16.0	12.0	12.0	8.0	16.4m/4.0	12.0	12.0	8.0	16.9m/4.0	12.0	12.0	8.0	17.5m/4.0	16.0
18.0	12.0	12.0	8.0	4.0	12.0	12.0	8.0	4.0	12.0	12.0	8.0	4.0	18.0
20.0	12.0	12.0	8.0	4.0	12.0	12.0	8.0	4.0	12.0	12.0	8.0	4.0	20.0
22.0	12.0	12.0	7.6	4.0	12.0	12.0	7.8	4.0	12.0	12.0	8.0	4.0	22.0
24.0	12.0	12.0	7.3	4.0	12.0	12.0	7.4	4.0	12.0	12.0	7.6	4.0	24.0
26.0	12.0	12.0	7.0	4.0	12.0	12.0	7.1	4.0	12.0	12.0	7.3	4.0	26.0
28.0	12.0	11.8	6.7	3.9	12.0	12.0	6.9	4.0	12.0	12.0	7.0	4.0	28.0
30.0	12.0	11.0	6.4	3.7	11.8	11.7	6.6	3.8	11.7	11.9	6.8	3.9	30.0
32.0	11.1	10.3	6.2	3.5	10.8	11.0	6.4	3.6	10.6	10.9	6.5	3.7	32.0
34.0	10.2	9.7	6.0	3.4	9.9	10.1	6.2	3.5	9.8	10.0	6.3	3.6	34.0
36.0		9.2	5.8	3.2	9.2	9.4	6.0	3.3	9.0	9.2	6.1	3.4	36.0
38.0		8.7	5.6	3.1		8.7	5.8	3.2	8.3	8.5	5.9	3.3	38.0
40.0		8.3	5.5	3.0		8.1	5.6	3.1		7.9	5.8	3.2	40.0
42.0			5.3	2.9		7.5	5.5	3.0		7.3	5.6	3.1	42.0
44.0			5.2	2.8			5.4	2.9		6.9	5.5	3.0	44.0
46.0				2.7			5.2	2.8			5.4	2.9	46.0
48.0				2.6			5.2	2.7			5.3	2.8	48.0
50.0				2.6				2.6			5.2	2.7	50.0
52.0								2.6				2.6	52.0
54.0												2.6	54.0
56.0												2.5	56.0
Reeves	1	1	1	1	1	1	1	1	1	1	1	1	Reeves

Boom length (m)	33.5				36.6				39.6				Boom length (m)
Jib length (m)	12.2	18.3	24.4	30.5	12.2	18.3	24.4	30.5	12.2	18.3	24.4	30.5	Jib length (m)
10.0	11.7m/12.0												10.0
12.0	12.0	13.8m/12.0			12.3m/12.0				12.8m/12.0				12.0
14.0	12.0	12.0	15.9m/8.0		12.0	14.4m/12.0			12.0	14.9m/12.0			14.0
16.0	12.0	12.0	8.0		12.0	12.0	16.4m/8.0		12.0	12.0	17.0m/8.0		16.0
18.0	12.0	12.0	8.0	4.0	12.0	12.0	8.0	18.5m/4.0	12.0	12.0	8.0	19.1m/4.0	18.0
20.0	12.0	12.0	8.0	4.0	12.0	12.0	8.0	4.0	12.0	12.0	8.0	4.0	20.0
22.0	12.0	12.0	8.0	4.0	12.0	12.0	8.0	4.0	12.0	12.0	8.0	4.0	22.0
24.0	12.0	12.0	7.8	4.0	12.0	12.0	7.9	4.0	12.0	12.0	8.0	4.0	24.0
26.0	12.0	12.0	7.5	4.0	12.0	12.0	7.6	4.0	12.0	12.0	7.8	4.0	26.0
28.0	12.0	12.0	7.2	4.0	12.0	12.0	7.3	4.0	12.0	12.0	7.5	4.0	28.0
30.0	11.5	11.7	6.9	4.0	11.3	11.5	7.1	4.0	11.1	11.4	7.2	4.0	30.0
32.0	10.5	10.7	6.7	3.8	10.3	10.5	6.9	3.9	10.1	10.3	7.0	4.0	32.0
34.0	9.6	9.8	6.5	3.7	9.4	9.6	6.6	3.8	9.2	9.4	6.8	3.9	34.0
36.0	8.8	9.0	6.3	3.5	8.6	8.8	6.4	3.6	8.4	8.7	6.6	3.7	36.0
38.0	8.1	8.3	6.1	3.4	7.9	8.1	6.2	3.5	7.8	8.0	6.4	3.6	38.0
40.0	7.5	7.7	5.9	3.3	7.3	7.5	6.1	3.4	7.1	7.3	6.2	3.5	40.0
42.0	7.0	7.2	5.8	3.2	6.8	6.9	5.9	3.3	6.6	6.8	6.0	3.4	42.0
44.0		6.7	5.6	3.1	6.3	6.4	5.8	3.2	6.1	6.3	5.9	3.2	44.0
46.0		6.2	5.5	3.0		6.0	5.6	3.1	5.7	5.8	5.8	3.1	46.0
48.0			5.4	2.9		5.6	5.5	3.0		5.4	5.6	3.0	48.0
50.0			5.3	2.8		5.2	5.4	2.9		5.1	5.3	3.0	50.0
52.0			5.2	2.7			5.1	2.8		4.7	4.9	2.9	52.0
54.0				2.7			4.7	2.7			4.6	2.8	54.0
56.0				2.6			4.5	2.7			4.3	2.7	56.0
58.0				2.5				2.6			4.0	2.7	58.0
60.0								2.5				2.6	60.0
62.0												2.6	62.0
64.0												2.5	64.0
Reeves	1	1	1	1	1	1	1	1	1	1	1	1	Reeves

Note:

Ratings according to Japanese Construction Codes for Mobile Cranes and Japanese Safety Ordinance on Cranes, etc.

Ratings shown in are determined by the strength of the boom or other structural components.

Lifting capacities may vary depending on hook used or with/without auxiliary sheave.

Please refer rated chart in operator's cabin.



Fixed Jib Lifting Capacities (Without Main Hook Block) (Jib Offset Angle : 10°)

Counterweight: 53.1 t

Unit: metric ton

Boom length (m)		42.7				45.7				48.8				Boom length (m)
Jib length (m)		12.2	18.3	24.4	30.5	12.2	18.3	24.4	30.5	12.2	18.3	24.4	30.5	Jib length (m)
Working radius (m)	12.0	13.3m/12.0				13.9m/12.0								12.0
	14.0	12.0	15.4m/12.0			12.0	15.9m/12.0			14.4m/12.0				14.0
	16.0	12.0	12.0	17.5m/8.0		12.0	12.0			12.0	16.5m/12.0			16.0
	18.0	12.0	12.0	8.0	19.6m/4.0	12.0	12.0	8.0		12.0	12.0	18.6m/8.0		18.0
	20.0	12.0	12.0	8.0	4.0	12.0	12.0	8.0	20.1m/4.0	12.0	12.0	8.0	20.6m/4.0	20.0
	22.0	12.0	12.0	8.0	4.0	12.0	12.0	8.0	4.0	12.0	12.0	8.0	4.0	22.0
	24.0	12.0	12.0	8.0	4.0	12.0	12.0	8.0	4.0	12.0	12.0	8.0	4.0	24.0
	26.0	12.0	12.0	7.9	4.0	12.0	12.0	8.0	4.0	12.0	12.0	8.0	4.0	26.0
	28.0	12.0	12.0	7.6	4.0	11.9	12.0	7.8	4.0	11.8	12.0	7.9	4.0	28.0
	30.0	11.0	11.2	7.4	4.0	10.7	11.0	7.5	4.0	10.6	10.9	7.6	4.0	30.0
	32.0	9.9	10.2	7.1	4.0	9.7	10.0	7.3	4.0	9.6	9.8	7.4	4.0	32.0
	34.0	9.0	9.3	6.9	4.0	8.8	9.1	7.1	4.0	8.7	8.9	7.2	4.0	34.0
	36.0	8.3	8.5	6.7	3.8	8.0	8.3	6.8	3.9	7.9	8.1	7.0	4.0	36.0
	38.0	7.6	7.8	6.5	3.7	7.3	7.6	6.7	3.8	7.2	7.4	6.8	3.8	38.0
	40.0	7.0	7.2	6.3	3.6	6.7	7.0	6.5	3.6	6.6	6.8	6.6	3.7	40.0
	42.0	6.4	6.6	6.2	3.4	6.2	6.4	6.3	3.5	6.0	6.2	6.4	3.6	42.0
	44.0	5.9	6.1	6.0	3.3	5.7	5.9	6.2	3.4	5.5	5.7	6.0	3.5	44.0
	46.0	5.5	5.7	5.9	3.2	5.2	5.4	5.7	3.3	5.1	5.3	5.6	3.4	46.0
	48.0	5.1	5.2	5.5	3.1	4.8	5.0	5.3	3.2	4.7	4.9	5.1	3.3	48.0
	50.0	4.7	4.9	5.1	3.0	4.5	4.6	4.9	3.1	4.3	4.5	4.8	3.2	50.0
	52.0		4.5	4.8	3.0	4.1	4.3	4.5	3.0	4.0	4.1	4.4	3.1	52.0
	54.0		4.2	4.4	2.9		4.0	4.2	2.9	3.6	3.8	4.1	3.0	54.0
	56.0			4.1	2.8		3.7	3.9	2.9		3.5	3.8	2.9	56.0
	58.0			3.9	2.7		3.4	3.6	2.8		3.2	3.5	2.9	58.0
	60.0			3.6	2.7			3.4	2.7		2.9	3.2	2.8	60.0
	62.0				2.6			3.1	2.7			2.9	2.7	62.0
	64.0				2.6			2.9	2.6			2.6	2.7	64.0
	66.0				2.5				2.6			2.4	2.5	66.0
68.0								2.5				2.3	68.0	
70.0												2.1	70.0	
Reeves	1	1	1	1	1	1	1	1	1	1	1	1	Reeves	

Boom length (m)		51.8				54.9				57.9				Boom length (m)
Jib length (m)		12.2	18.3	24.4	30.5	12.2	18.3	24.4	30.5	12.2	18.3	24.4	30.5	Jib length (m)
Working radius (m)	14.0	14.9m/12.0				15.4m/12.0								14.0
	16.0	12.0	17.0m/12.0			12.0	17.5m/12.0			12.0				16.0
	18.0	12.0	12.0	19.1m/8.0		12.0	12.0	19.6m/8.0		12.0	18.1m/12.0			18.0
	20.0	12.0	12.0	8.0	21.2m/4.0	12.0	12.0	8.0	21.7m/4.0	12.0	12.0	20.1m/8.0		20.0
	22.0	12.0	12.0	8.0	4.0	12.0	12.0	8.0	4.0	12.0	12.0	8.0	22.2m/4.0	22.0
	24.0	12.0	12.0	8.0	4.0	12.0	12.0	8.0	4.0	12.0	12.0	8.0	4.0	24.0
	26.0	12.0	12.0	8.0	4.0	12.0	12.0	8.0	4.0	12.0	12.0	8.0	4.0	26.0
	28.0	11.6	11.9	8.0	4.0	11.4	11.7	8.0	4.0	11.2	11.5	8.0	4.0	28.0
	30.0	10.4	10.7	7.8	4.0	10.2	10.5	7.9	4.0	10.0	10.3	8.0	4.0	30.0
	32.0	9.4	9.7	7.5	4.0	9.2	9.5	7.6	4.0	9.0	9.3	7.7	4.0	32.0
	34.0	8.5	8.8	7.3	4.0	8.3	8.6	7.4	4.0	8.1	8.4	7.5	4.0	34.0
	36.0	7.7	8.0	7.1	4.0	7.5	7.8	7.2	4.0	7.3	7.6	7.3	4.0	36.0
	38.0	7.0	7.3	6.9	3.9	6.8	7.1	7.0	4.0	6.6	6.9	7.1	4.0	38.0
	40.0	6.4	6.6	6.7	3.8	6.2	6.4	6.8	3.9	6.0	6.2	6.6	3.9	40.0
	42.0	5.9	6.1	6.4	3.7	5.6	5.9	6.2	3.7	5.5	5.7	6.0	3.8	42.0
	44.0	5.4	5.6	5.9	3.6	5.1	5.4	5.7	3.6	4.9	5.2	5.5	3.7	44.0
	46.0	4.9	5.1	5.4	3.4	4.7	4.9	5.2	3.5	4.5	4.7	5.0	3.6	46.0
	48.0	4.5	4.7	5.0	3.4	4.3	4.5	4.8	3.4	4.0	4.3	4.6	3.5	48.0
	50.0	4.1	4.3	4.6	3.3	3.8	4.1	4.4	3.3	3.6	3.9	4.2	3.4	50.0
	52.0	3.7	4.0	4.2	3.2	3.4	3.7	4.0	3.2	3.2	3.4	3.9	3.3	52.0
	54.0	3.4	3.6	3.9	3.1	3.0	3.3	3.7	3.2	2.8	3.1	3.5	3.2	54.0
	56.0	3.0	3.3	3.6	3.0	2.7	3.0	3.3	3.1	2.4	2.7	3.1	3.1	56.0
	58.0		2.9	3.3	2.9	2.4	2.6	3.0	3.0	2.1	2.4	2.8	2.9	58.0
	60.0		2.6	3.0	2.9		2.3	2.7	2.8		2.1	2.4	2.6	60.0
	62.0		2.4	2.7	2.8		2.1	2.4	2.5			2.2	2.3	62.0
	64.0			2.4	2.5			2.1	2.3				2.0	64.0
	66.0			2.2	2.3				2.0					66.0
	68.0				2.0									68.0
Reeves	1	1	1	1	1	1	1	1	1	1	1	1	Reeves	

Note:

Ratings according to Japanese Construction Codes for Mobile Cranes and Japanese Safety Ordinance on Cranes, etc.

Ratings shown in are determined by the strength of the boom or other structural components.

Lifting capacities may vary depending on hook used or with/without auxiliary sheave.

Please refer rated chart in operator's cabin.

LIFTING CAPACITIES



Fixed Jib Lifting Capacities (Without Main Hook Block) (Jib Offset Angle : 10°)

Counterweight: 53.1 t

Unit: metric ton

Boom length (m)		61.0										Boom length (m)
Jib length (m)		12.2	18.3	24.4	30.5							Jib length (m)
Working radius (m)	16.0	16.5m/12.0										16.0
	18.0	12.0	18.6m/12.0									18.0
	20.0	12.0	12.0	20.7m/8.0								20.0
	22.0	12.0	12.0	8.0	22.8m/4.0							22.0
	24.0	12.0	12.0	8.0	4.0							24.0
	26.0	12.0	12.0	8.0	4.0							26.0
	28.0	11.1	11.4	8.0	4.0							28.0
	30.0	9.9	10.2	8.0	4.0							30.0
	32.0	8.9	9.1	7.8	4.0							32.0
	34.0	8.0	8.2	7.6	4.0							34.0
	36.0	7.2	7.4	7.4	4.0							36.0
	38.0	6.5	6.7	7.1	4.0							38.0
	40.0	5.8	6.1	6.4	4.0							40.0
	42.0	5.3	5.5	5.9	3.9							42.0
	44.0	4.8	5.0	5.4	3.8							44.0
	46.0	4.3	4.5	4.9	3.7							46.0
	48.0	3.8	4.1	4.5	3.6							48.0
	50.0	3.3	3.6	4.1	3.5							50.0
	52.0	2.9	3.2	3.6	3.4							52.0
	54.0	2.5	2.8	3.2	3.3							54.0
56.0	2.2	2.5	2.9	3.0							56.0	
58.0		2.1	2.5	2.7							58.0	
60.0			2.2	2.4							60.0	
62.0				2.1							62.0	
Reeves		1	1	1	1							Reeves

Note:

Ratings according to Japanese Construction Codes for Mobile Cranes and Japanese Safety Ordinance on Cranes, etc.

Ratings shown in are determined by the strength of the boom or other structural components.

Lifting capacities may vary depending on hook used or with/without auxiliary sheave.

Please refer rated chart in operator's cabin.

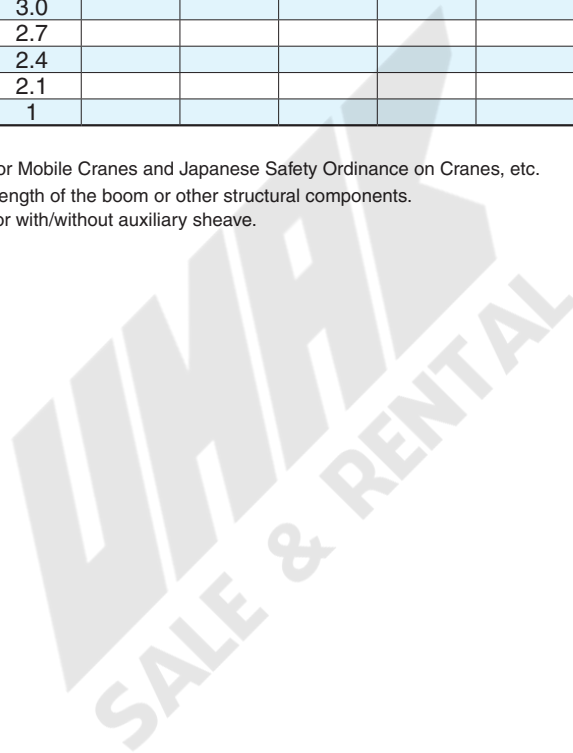



Fixed Jib Lifting Capacities (Without Main Hook Block) (Jib Offset Angle : 30°)

Counterweight: 53.1 t

Unit: metric ton

Boom length (m)		24.4				27.4				30.5				Boom length (m)	
Jib length (m)		12.2	18.3	24.4	30.5	12.2	18.3	24.4	30.5	12.2	18.3	24.4	30.5	Jib length (m)	
Working radius (m)	12.0	13.8m/10.0												12.0	
	14.0	10.0				14.3m/10.0				14.9m/10.0				14.0	
	16.0	10.0	17.7m/9.0			10.0				10.0				16.0	
	18.0	10.0	9.0			10.0	18.3m/9.0			10.0	18.8m/9.0			18.0	
	20.0	10.0	9.0	21.7m/6.0		10.0	9.0			10.0	9.0			20.0	
	22.0	10.0	9.0	6.0		10.0	9.0	22.2m/6.0		10.0	9.0	22.7m/6.0		22.0	
	24.0	10.0	9.0	6.0	25.6m/3.0	10.0	9.0	6.0		10.0	9.0	6.0		24.0	
	26.0	10.0	9.0	6.0	3.0	10.0	9.0	6.0	26.1m/3.0	10.0	9.0	6.0	26.6m/3.0	26.0	
	28.0	10.0	8.7	5.8	3.0	10.0	9.0	5.9	3.0	10.0	9.0	6.0	3.0	28.0	
	30.0	10.0	8.3	5.7	3.0	10.0	8.6	5.8	3.0	10.0	8.9	5.8	3.0	30.0	
	32.0	10.0	7.9	5.5	3.0	10.0	8.2	5.6	3.0	10.0	8.5	5.7	3.0	32.0	
	34.0	10.0	7.6	5.4	2.9	10.0	7.9	5.5	3.0	9.9	8.1	5.6	3.0	34.0	
	36.0		7.3	5.3	2.8	9.3	7.6	5.4	2.9	9.1	7.8	5.5	2.9	36.0	
	38.0		7.1	5.2	2.7		7.3	5.3	2.8	8.4	7.5	5.4	2.8	38.0	
	40.0		6.9	5.1	2.7		7.1	5.2	2.7	7.8	7.3	5.3	2.8	40.0	
	42.0			5.0	2.6		6.9	5.1	2.7		7.1	5.2	2.7	42.0	
	44.0			4.8	2.6			5.0	2.6		7.0	5.1	2.6	44.0	
	46.0			4.7	2.5			4.8	2.5		6.5	5.0	2.6	46.0	
	48.0				2.5			4.7	2.5			4.8	2.5	48.0	
	50.0				2.4				2.5			4.8	2.5	50.0	
52.0				2.4				2.4			4.7	2.5	52.0		
54.0								2.4				2.4	54.0		
56.0												2.4	56.0		
58.0												2.4	58.0		
Reeves	1	1	1	1	1	1	1	1	1	1	1	1	Reeves		

Boom length (m)		33.5				36.6				39.6				Boom length (m)	
Jib length (m)		12.2	18.3	24.4	30.5	12.2	18.3	24.4	30.5	12.2	18.3	24.4	30.5	Jib length (m)	
Working radius (m)	14.0	15.4m/10.0				15.9m/10.0								14.0	
	16.0	10.0				10.0				16.5m/10.0				16.0	
	18.0	10.0	19.3m/9.0			10.0	19.9m/9.0			10.0				18.0	
	20.0	10.0	9.0			10.0	9.0			10.0	20.4m/9.0			20.0	
	22.0	10.0	9.0	23.2m/6.0		10.0	9.0	23.8m/6.0		10.0	9.0			22.0	
	24.0	10.0	9.0	6.0		10.0	9.0	6.0		10.0	9.0	24.3m/6.0		24.0	
	26.0	10.0	9.0	6.0	27.2m/3.0	10.0	9.0	6.0	27.7m/3.0	10.0	9.0	6.0		26.0	
	28.0	10.0	9.0	6.0	3.0	10.0	9.0	6.0	3.0	10.0	9.0	6.0	28.2m/3.0	28.0	
	30.0	10.0	9.0	5.9	3.0	10.0	9.0	6.0	3.0	10.0	9.0	6.0	3.0	30.0	
	32.0	10.0	8.7	5.8	3.0	10.0	9.0	5.8	3.0	10.0	9.0	5.9	3.0	32.0	
	34.0	9.8	8.4	5.6	3.0	9.6	8.6	5.7	3.0	9.5	8.9	5.8	3.0	34.0	
	36.0	9.0	8.1	5.5	3.0	8.8	8.3	5.6	3.0	8.7	8.5	5.6	3.0	36.0	
	38.0	8.3	7.8	5.4	2.9	8.1	8.0	5.5	2.9	7.9	8.2	5.5	3.0	38.0	
	40.0	7.6	7.5	5.3	2.8	7.4	7.8	5.4	2.8	7.3	7.7	5.4	2.9	40.0	
	42.0	7.1	7.3	5.2	2.7	6.9	7.3	5.3	2.8	6.7	7.1	5.4	2.8	42.0	
	44.0		6.9	5.2	2.7	6.3	6.7	5.2	2.7	6.2	6.6	5.3	2.7	44.0	
	46.0		6.4	5.1	2.6		6.2	5.2	2.7	5.7	6.1	5.2	2.7	46.0	
	48.0		6.0	5.0	2.6		5.8	5.1	2.6	5.3	5.7	5.2	2.6	48.0	
	50.0			4.9	2.5		5.4	5.0	2.6		5.3	5.1	2.6	50.0	
	52.0			4.8	2.5			4.9	2.5		4.9	5.0	2.5	52.0	
54.0			4.7	2.5			4.8	2.5		4.5	4.8	2.5	54.0		
56.0				2.4			4.6	2.5			4.5	2.5	56.0		
58.0				2.4				2.4			4.1	2.5	58.0		
60.0				2.4				2.4			3.9	2.4	60.0		
62.0								2.4				2.4	62.0		
64.0												2.4	64.0		
66.0												2.4	66.0		
Reeves	1	1	1	1	1	1	1	1	1	1	1	1	Reeves		

Note:

Ratings according to Japanese Construction Codes for Mobile Cranes and Japanese Safety Ordinance on Cranes, etc.

Ratings shown in are determined by the strength of the boom or other structural components.

Lifting capacities may vary depending on hook used or with/without auxiliary sheave.

Please refer rated chart in operator's cabin.

LIFTING CAPACITIES



Fixed Jib Lifting Capacities (Without Main Hook Block) (Jib Offset Angle : 30°)

Counterweight: 53.1 t

Unit: metric ton

Boom length (m)		42.7				45.7				48.8				Boom length (m)
Jib length (m)		12.2	18.3	24.4	30.5	12.2	18.3	24.4	30.5	12.2	18.3	24.4	30.5	Jib length (m)
Working radius (m)	16.0	17.0m/10.0				17.5m/10.0								16.0
	18.0	10.0				10.0				18.1m/10.0				18.0
	20.0	10.0	20.9m/9.0			10.0	21.4m/9.0			10.0				20.0
	22.0	10.0	9.0			10.0	9.0			10.0	9.0			22.0
	24.0	10.0	9.0	24.8m/6.0		10.0	9.0	25.4m/6.0		10.0	9.0	25.9m/6.0		24.0
	26.0	10.0	9.0	6.0		10.0	9.0	6.0		10.0	9.0	6.0		26.0
	28.0	10.0	9.0	6.0	28.8m/3.0	10.0	9.0	6.0	29.3m/3.0	10.0	9.0	6.0	29.8m/3.0	28.0
	30.0	10.0	9.0	6.0	3.0	10.0	9.0	6.0	3.0	10.0	9.0	6.0	3.0	30.0
	32.0	10.0	9.0	5.9	3.0	10.0	9.0	6.0	3.0	10.0	9.0	6.0	3.0	32.0
	34.0	9.3	9.0	5.8	3.0	9.1	9.0	5.9	3.0	9.0	9.0	5.9	3.0	34.0
	36.0	8.5	8.7	5.7	3.0	8.3	8.8	5.8	3.0	8.2	8.7	5.8	3.0	36.0
	38.0	7.8	8.3	5.6	3.0	7.6	8.1	5.7	3.0	7.5	8.0	5.7	3.0	38.0
	40.0	7.1	7.6	5.5	2.9	7.0	7.4	5.6	2.9	6.8	7.3	5.6	3.0	40.0
	42.0	6.6	7.0	5.4	2.8	6.4	6.8	5.5	2.9	6.2	6.7	5.5	2.9	42.0
	44.0	6.1	6.5	5.3	2.8	5.8	6.3	5.4	2.8	5.7	6.2	5.4	2.8	44.0
	46.0	5.6	6.0	5.3	2.7	5.4	5.8	5.3	2.8	5.2	5.7	5.4	2.8	46.0
	48.0	5.1	5.5	5.2	2.7	4.9	5.3	5.2	2.7	4.8	5.2	5.3	2.7	48.0
	50.0	4.8	5.1	5.1	2.6	4.6	4.9	5.2	2.7	4.4	4.8	5.1	2.7	50.0
	52.0		4.7	5.0	2.6	4.2	4.6	4.8	2.6	4.1	4.4	4.7	2.6	52.0
	54.0		4.4	4.6	2.5		4.2	4.5	2.6	3.7	4.1	4.4	2.6	54.0
	56.0		4.1	4.3	2.5		3.9	4.1	2.5	3.4	3.8	4.0	2.6	56.0
58.0			4.0	2.5		3.6	3.8	2.5		3.5	3.7	2.5	58.0	
60.0			3.7	2.4			3.6	2.5		3.1	3.4	2.5	60.0	
62.0			3.5	2.4			3.3	2.4		2.8	3.2	2.5	62.0	
64.0				2.4			3.0	2.4			2.8	2.4	64.0	
66.0				2.4				2.4			2.6	2.4	66.0	
68.0				2.4				2.4			2.3	2.4	68.0	
70.0												2.3	70.0	
72.0								2.4				2.1	72.0	
Reeves	1	1	1	1	1	1	1	1	1	1	1	1	Reeves	

Boom length (m)		51.8				54.9				57.9				Boom length (m)
Jib length (m)		12.2	18.3	24.4	30.5	12.2	18.3	24.4	30.5	12.2	18.3	24.4	30.5	Jib length (m)
Working radius (m)	18.0	18.6m/10.0				19.1m/10.0				19.6m/10.0				18.0
	20.0	10.0				10.0				10.0				20.0
	22.0	10.0	22.5m/9.0			10.0	23.0m/9.0			10.0	23.6m/9.0			22.0
	24.0	10.0	9.0			10.0	9.0			10.0	9.0			24.0
	26.0	10.0	9.0	26.4m/6.0		10.0	9.0	26.9m/6.0		10.0	9.0	27.5m/6.0		26.0
	28.0	10.0	9.0	6.0		10.0	9.0	6.0		10.0	9.0	6.0		28.0
	30.0	10.0	9.0	6.0	30.3m/3.0	10.0	9.0	6.0	30.9m/3.0	10.0	9.0	6.0	31.4m/3.0	30.0
	32.0	9.8	9.0	6.0	3.0	9.6	9.0	6.0	3.0	9.5	9.0	6.0	3.0	32.0
	34.0	8.9	9.0	6.0	3.0	8.7	9.0	6.0	3.0	8.5	9.0	6.0	3.0	34.0
	36.0	8.1	8.6	5.9	3.0	7.9	8.5	5.9	3.0	7.7	8.3	5.9	3.0	36.0
	38.0	7.3	7.9	5.8	3.0	7.1	7.7	5.8	3.0	7.0	7.6	5.8	3.0	38.0
	40.0	6.7	7.2	5.7	3.0	6.5	7.0	5.7	3.0	6.3	6.9	5.7	3.0	40.0
	42.0	6.1	6.6	5.6	2.9	5.9	6.4	5.6	3.0	5.7	6.3	5.7	3.0	42.0
	44.0	5.6	6.0	5.5	2.9	5.4	5.9	5.5	2.9	5.2	5.7	5.6	2.9	44.0
	46.0	5.1	5.5	5.4	2.8	4.9	5.4	5.5	2.8	4.7	5.2	5.5	2.9	46.0
	48.0	4.7	5.1	5.3	2.8	4.5	4.9	5.2	2.8	4.3	4.8	5.1	2.8	48.0
	50.0	4.3	4.7	5.0	2.7	4.1	4.5	4.8	2.7	3.8	4.4	4.7	2.8	50.0
	52.0	3.9	4.3	4.6	2.7	3.6	4.1	4.4	2.7	3.4	4.0	4.3	2.7	52.0
	54.0	3.5	4.0	4.2	2.6	3.2	3.8	4.1	2.6	3.0	3.6	3.9	2.7	54.0
	56.0	3.1	3.6	3.9	2.6	2.8	3.4	3.7	2.6	2.6	3.2	3.6	2.6	56.0
	58.0	2.8	3.3	3.6	2.5	2.5	3.0	3.4	2.6	2.3	2.8	3.2	2.6	58.0
60.0		2.9	3.3	2.5	2.2	2.7	3.1	2.5	2.0	2.5	2.9	2.6	60.0	
62.0		2.6	3.0	2.5		2.4	2.7	2.5		2.2	2.5	2.5	62.0	
64.0		2.3	2.7	2.5		2.1	2.4	2.5			2.2	2.5	64.0	
66.0			2.4	2.4			2.1	2.4				2.2	66.0	
68.0			2.1	2.4				2.1					68.0	
70.0				2.1									70.0	
Reeves	1	1	1	1	1	1	1	1	1	1	1	1	Reeves	

Note:

Ratings according to Japanese Construction Codes for Mobile Cranes and Japanese Safety Ordinance on Cranes, etc.

Ratings shown in are determined by the strength of the boom or other structural components.

Lifting capacities may vary depending on hook used or with/without auxiliary sheave.

Please refer rated chart in operator's cabin.



Fixed Jib Lifting Capacities (Without Main Hook Block) (Jib Offset Angle : 30°)

Counterweight: 53.1 t

Unit: metric ton

Boom length (m)		61.0										Boom length (m)
Jib length (m)		12.2	18.3	24.4	30.5							Jib length (m)
Working radius (m)	20.0	20.1m/10.0										20.0
	22.0	10.0										22.0
	24.0	10.0	24.1m/9.0									24.0
	26.0	10.0	9.0									26.0
	28.0	10.0	9.0	6.0								28.0
	30.0	10.0	9.0	6.0	31.9m/3.0							30.0
	32.0	9.3	9.0	6.0	3.0							32.0
	34.0	8.4	9.0	6.0	3.0							34.0
	36.0	7.6	8.2	6.0	3.0							36.0
	38.0	6.8	7.4	5.9	3.0							38.0
	40.0	6.2	6.8	5.8	3.0							40.0
	42.0	5.6	6.1	5.7	3.0							42.0
	44.0	5.1	5.6	5.6	3.0							44.0
	46.0	4.6	5.1	5.5	2.9							46.0
	48.0	4.1	4.6	5.0	2.8							48.0
	50.0	3.6	4.2	4.6	2.8							50.0
	52.0	3.2	3.8	4.2	2.7							52.0
	54.0	2.8	3.4	3.8	2.7							54.0
	56.0	2.4	3.0	3.4	2.7							56.0
	58.0	2.0	2.6	3.0	2.6							58.0
60.0		2.3	2.7	2.6							60.0	
62.0		2.0	2.3	2.5							62.0	
64.0			2.0	2.3							64.0	
66.0				2.0							66.0	
Reeves	1	1	1	1							Reeves	

Note:

Ratings according to Japanese Construction Codes for Mobile Cranes and Japanese Safety Ordinance on Cranes, etc.

Ratings shown in are determined by the strength of the boom or other structural components.

Lifting capacities may vary depending on hook used or with/without auxiliary sheave.

Please refer rated chart in operator's cabin.

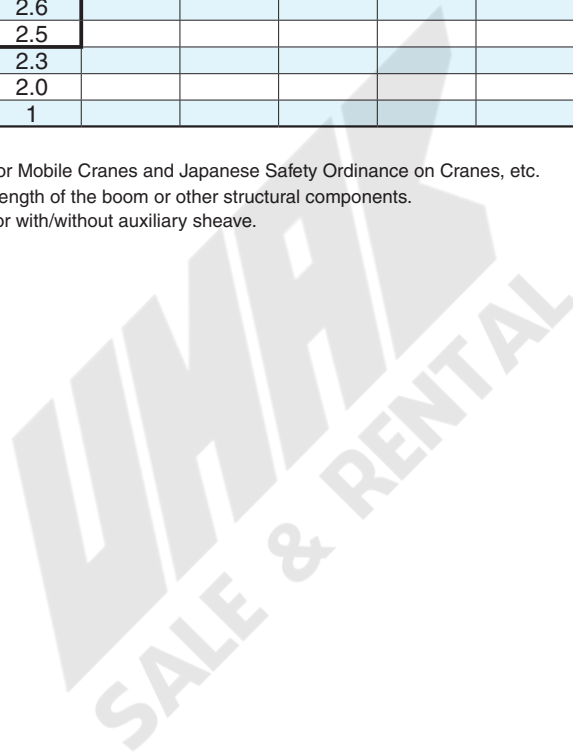

LIFTING CAPACITIES



Long Boom Lifting Capacities

Counterweight: 53.1 t

Unit: metric ton

Working radius (m) \ Boom length (m)	61.0	64.0	67.1	70.1	73.2	76.2	79.2	Working radius (m) \ Boom length (m)
12.0	12.3m/24.0	12.8m/24.0	13.3m/24.0	13.9m/24.0				12.0
14.0	24.0	24.0	24.0	24.0	14.4m/22.1	14.9m/18.7	15.4m/16.3	14.0
16.0	24.0	24.0	24.0	24.0	20.9	17.9	15.9	16.0
18.0	22.8	22.6	22.5	22.5	19.5	16.7	14.8	18.0
20.0	19.7	19.5	19.5	19.4	18.3	15.7	13.9	20.0
22.0	17.3	17.1	17.0	17.0	16.9	14.8	13.1	22.0
24.0	15.3	15.1	15.0	15.0	14.9	14.0	12.3	24.0
26.0	13.7	13.5	13.4	13.4	13.3	13.1	11.7	26.0
28.0	12.3	12.1	12.0	12.0	11.9	11.7	11.2	28.0
30.0	11.1	10.9	10.8	10.8	10.7	10.6	10.5	30.0
32.0	10.1	9.9	9.8	9.8	9.7	9.5	9.5	32.0
34.0	9.2	9.0	8.9	8.9	8.8	8.7	8.6	34.0
36.0	8.4	8.3	8.2	8.1	8.0	7.9	7.8	36.0
38.0	7.8	7.6	7.5	7.5	7.4	7.2	7.2	38.0
40.0	7.2	7.0	6.9	6.8	6.7	6.6	6.5	40.0
42.0	6.6	6.4	6.3	6.3	6.2	6.0	6.0	42.0
44.0	6.1	5.9	5.8	5.8	5.7	5.5	5.5	44.0
46.0	5.7	5.5	5.4	5.3	5.2	5.1	5.0	46.0
48.0	5.3	5.1	5.0	4.9	4.8	4.7	4.6	48.0
50.0	4.9	4.7	4.6	4.6	4.5	4.3	4.3	50.0
52.0	4.6	4.4	4.3	4.2	4.1	4.0	3.9	52.0
54.0	4.3	4.1	3.9	3.9	3.8	3.6	3.5	54.0
56.0	54.4m/4.2	3.8	3.7	3.6	3.5	3.3	3.2	56.0
58.0		57.0m/3.6	3.4	3.3	3.2	2.9	2.9	58.0
60.0			59.7m/3.1	3.0	2.9	2.6	2.6	60.0
62.0				2.8	2.6	2.4	2.3	62.0
64.0				62.3m/2.7	2.4	2.1	2.0	64.0
66.0					64.9m/2.2			66.0
Reeves	2	2	2	2	2	2	2	Reeves

Note:

Ratings according to Japanese Construction Codes for Mobile Cranes and Japanese Safety Ordinance on Cranes, etc.

Ratings shown in are determined by the strength of the boom or other structural components.

Lifting capacities may vary depending on hook used or with/without auxiliary sheave.

Please refer rated chart in operator's cabin.

SALE & RENTAL

- Ratings according to Japanese Construction Codes for Mobile Cranes.
- Operating radius is the horizontal distance from centerline of rotation to a vertical line through the center of gravity of the load.
- Ratings shown are based on freely suspended loads and make no allowance for such factors as wind effect on lifted load, ground conditions, out-of-level, operating speeds or any other condition that could be detrimental to the safe operation of this equipment. The operator, therefore, has the responsibility to judge the existing conditions and reduce lifted loads and operating speeds accordingly.
- Ratings are for operation on a firm and level surface, up to 1% gradient.
- At radii and boom lengths where no ratings are shown on chart, operation is not intended nor approved.
- Tower and jib inserts and guy lines must be arranged as shown in the "Operator's Manual".
- Tower hoist reeving is 12 part line.
- Jib hoist reeving is 8 part line.
- Gantry must be in raised position for all conditions.
- Tower and jib backstops are required for all tower and jib combinations.
- Ratings inside of boxes are limited by strength of materials.
- The tower should be erected over the front of the crawlers, not laterally.
- When erecting and lowering the tower length of 51.7 m, the blocks for erection must be placed at the end of the crawlers.
- The minimum rated load is 2.0 (ton).
- The total load that can be lifted is the value for weight of hook block, slings, and all other load handling accessories deducted from tower jib ratings shown.
- One part of line on hook is not allowed to use for 22.9 m jib length.

Tower and jib combinations

		Jib Length (m)							
		22.9	25.9	29.0	32.0	35.1	38.1	41.1	44.2
Tower Length (m)	30.4	○*	○	×	×	×	×	×	×
	33.4	○*	○	○	×	×	×	×	×
	36.5	○*	○	○	○	×	×	×	×
	39.5	○*	○	○	○	○	×	×	×
	42.5	○*	○	○	○	○	○	×	×
	45.6	○*	○	○	○	○	○	○	×
	48.6	○*	○	○	○	○	○	○	○
	51.7	○*	○	○	○	○	○	○	○

- : Combinations which is allowed.
- * : One part of line on hook is not allowed to use.

- Maximum hoist load for number of reeving parts of line for hoist rope.

For jib hook

No. of Parts of Line	1	2
Maximum Loads (kN)	118	196
Maximum Loads (t)	12.0	20.0

Weight of hook block		
Hook Block	35 t	Ball Hook
Weight (t)	0.9	0.45

Operation of this equipment in excess of rated loads or disregard of instruction voids the warranty.

LIFTING CAPACITIES



Tower Jib Lifting Capacities

Counterweight: 53.1 t

Unit: metric ton

30.4 m Tower Length	Tower length (m)	30.4								Tower length (m)	
	Jib length (m)	22.9				25.9				Jib length (m)	
	Tower angle	90°	80°	70°	60°	90°	80°	70°	60°	Tower angle	
Working radius (m)	9.4	20.0									9.4
	10.0	20.0				10.2m/20.0					10.0
	12.0	20.0				20.0					12.0
	14.0	20.0				20.0					14.0
	15.0	20.0				20.0					15.0
	16.0	18.7				18.7					16.0
	18.0	16.6	18.4m/16.3			16.6	19.7m/15.2				18.0
	20.0	15.0	15.0			15.0	15.0				20.0
	22.0	13.3	13.6			13.6	13.6				22.0
	24.0	9.9	12.5			12.1	12.5				24.0
	26.0	25.4m/7.1	11.5	26.8m/11.1		9.5	11.5				26.0
	28.0		10.7	10.7		6.7	10.7	28.6m/10.4			28.0
	30.0		10.0	10.0		28.3m/6.1	10.0	10.0			30.0
	32.0		30.6m/9.4	9.3			9.3	9.3			32.0
	34.0			8.8	34.5m/8.5		33.5m/7.7	8.8			34.0
	36.0			35.6m/8.4	7.9			8.3	36.7m/7.7		36.0
	38.0				7.5			7.8	7.3		38.0
	40.0				7.0			38.6m/7.7	6.9		40.0
42.0				40.3m/6.9				6.4		42.0	
44.0								43.2m/6.2		44.0	
Reeves	2	2	2	2	2	2	2	2	2	Reeves	

33.4 m Tower Length	Tower length (m)	33.4												Tower length (m)
	Jib length (m)	22.9				25.9				29.0				Jib length (m)
	Tower angle	90°	80°	70°	60°	90°	80°	70°	60°	90°	80°	70°	60°	Tower angle
Working radius (m)	9.4	20.0												9.4
	10.0	20.0				10.2m/20.0				11.0m/20.0				10.0
	12.0	20.0				20.0				20.0				12.0
	14.0	20.0				20.0				20.0				14.0
	15.0	20.0				20.0				20.0				15.0
	16.0	18.7				18.7				18.7				16.0
	18.0	16.6	18.9m/15.8			16.6				16.6				18.0
	20.0	15.0	15.0			15.0	20.2m/14.8			15.0	21.5m/13.9			20.0
	22.0	13.4	13.6			13.6	13.6			13.6	13.6			22.0
	24.0	10.0	12.5			12.3	12.5			12.5	12.5			24.0
	26.0	25.4m/7.2	11.5	27.9m/10.7		9.7	11.5			11.2	11.5			26.0
	28.0		10.7	10.7		6.9	10.7	29.6m/10.1		9.1	10.7			28.0
	30.0		10.0	10.0		28.3m/6.2	10.0	10.0		7.0	10.0	31.4m/9.5		30.0
	32.0		31.1m/9.5	9.3			9.3	9.3		31.2m/5.3	9.3	9.3		32.0
	34.0			8.8			8.6	8.8			8.8	8.8		34.0
	36.0			8.3	7.6		34.1m/8.1	8.3			8.3	8.3		36.0
	38.0			36.7m/8.1	7.0			7.8	38.2m/6.9		37.0m/7.0	7.8		38.0
	40.0				6.6			39.6m/7.5	6.4			7.4	40.3m/6.3	40.0
42.0				41.8m/6.2				6.1			6.9	5.8	42.0	
44.0								5.7			42.6m/6.8	5.6	44.0	
46.0								44.8m/5.6				5.2	46.0	
48.0												47.7m/5.0	48.0	
Reeves	2	2	2	2	2	2	2	2	2	2	2	2	Reeves	

Note:

Ratings according to Japanese Construction Codes for Mobile Cranes and Japanese Safety Ordinance on Cranes, etc.

Ratings shown in are determined by the strength of the tower or other structural components.

Lifting capacities may vary depending on hook used or with/without auxiliary sheave.

Please refer rated chart in operator's cabin.



Tower Jib Lifting Capacities

Counterweight: 53.1 t

Unit: metric ton

36.5 m Tower Length	36.5																	
	Tower length (m)	36.5																Tower length (m)
	Jib length (m)	22.9				25.9				29.0				32.0				Jib length (m)
Working radius (m)	Tower angle	90°	80°	70°	60°	90°	80°	70°	60°	90°	80°	70°	60°	90°	80°	70°	60°	Tower angle
9.4	20.0																	9.4
10.0	20.0					10.2m/20.0				11.0m/20.0				11.8m/20.0				10.0
12.0	20.0					20.0				20.0				20.0				12.0
14.0	20.0					20.0				20.0				19.6				14.0
15.0	20.0					20.0				20.0				19.1				15.0
16.0	18.7					18.7				18.7				18.6				16.0
18.0	16.6	19.4m/15.4				16.6				16.6				16.6				18.0
20.0	15.0	15.0				15.0	20.7m/14.4			15.0				15.0				20.0
22.0	13.5	13.6				13.6	13.6			13.6	13.6			13.6	23.3m/12.8			22.0
24.0	10.1	12.5				12.4	12.5			12.5	12.5			12.5	12.5			24.0
26.0	25.4m/7.3	11.5				9.8	11.5			11.2	11.5			11.5	11.5			26.0
28.0		10.7	28.9m/10.3			6.9	10.7			9.2	10.7			10.2	10.7			28.0
30.0		10.0	10.0			28.3m/6.3	10.0	30.7m/9.7		7.1	10.0			8.6	10.0			30.0
32.0		31.7m/9.4	9.3				9.3	9.3		31.2m/5.4	9.3	32.4m/9.2		6.9	9.3			32.0
34.0			8.8				8.8	8.8			8.8	8.7		5.0	8.8	34.2m/8.6		34.0
36.0			8.3	37.6m/6.8		34.6m/8.2	8.3			8.3	8.2		34.2m/4.6	8.3	8.0			36.0
38.0			37.7m/7.9	6.6			7.8	39.7m/6.2		37.6m/7.1	7.7			7.8	7.6			38.0
40.0				6.2			7.2	6.0			7.2	41.9m/5.6		7.0	7.1			40.0
42.0				5.8				40.7m/7.1	5.7		6.7	5.5		40.5m/6.2	6.6			42.0
44.0					43.3m/5.6				5.4			43.6m/6.3	5.2			6.2	5.0	44.0
46.0									5.0				4.9		5.9	4.7		46.0
48.0								46.3m/5.0					4.6		46.5m/5.7	4.6		48.0
50.0													49.2m/4.4				4.3	50.0
52.0																	4.0	52.0
54.0																	52.2m/3.8	54.0
Reeves	2	2	2	2	2	2	2	2	2	2	2	2	2	2	2	2	2	Reeves

39.5 m Tower Length	39.5																						
	Tower length (m)	39.5																		Tower length (m)			
	Jib length (m)	22.9				25.9				29.0				32.0				35.1				Jib length (m)	
Working radius (m)	Tower angle	90°	80°	70°	60°	90°	80°	70°	60°	90°	80°	70°	60°	90°	80°	70°	60°	90°	80°	70°	60°	Tower angle	
9.4	20.0																						9.4
10.0	20.0					10.2m/20.0				11.0m/20.0				11.8m/20.0									10.0
12.0	20.0					20.0				20.0				20.0				12.5m/16.5					12.0
14.0	20.0					20.0				20.0				19.6				16.3					14.0
15.0	20.0					20.0				20.0				19.1				16.0					15.0
16.0	18.7					18.7				18.7				18.6				15.7					16.0
18.0	16.6					16.6				16.6				16.6				15.3					18.0
20.0	15.0	15.0				15.0	21.2m/14.1			15.0				15.0				14.9					20.0
22.0	13.6	13.6				13.6	13.6			13.6	22.5m/13.3			13.6	23.8m/12.6			13.6					22.0
24.0	10.2	12.5				12.4	12.5			12.5	12.5			12.5	12.5			12.5	25.1m/11.9				24.0
26.0	25.4m/7.4	11.5				9.8	11.5			11.3	11.5			11.5	11.5			11.5	11.5				26.0
28.0		10.7				7.0	10.7			9.3	10.7			10.2	10.7			10.7	10.7				28.0
30.0		10.0	10.0			28.3m/6.3	10.0	31.7m/9.4		7.2	10.0			8.6	10.0			9.4	10.0				30.0
32.0		9.3	9.3				9.3	9.2		31.2m/5.4	9.3	33.5m/8.6		6.9	9.3			8.0	9.3				32.0
34.0		32.2m/9.3	8.7				8.8	8.6			8.8	8.4		5.0	8.8	35.2m/8.0		6.7	8.8				34.0
36.0			8.1			35.1m/8.2	8.0			8.3	7.9		34.2m/4.7	8.3	7.7			5.2	8.3	36.9m/7.4			36.0
38.0			7.5	39.1m/6.0			7.5			7.5	7.3			7.8	7.2			37.1m/4.1	7.8	7.0			38.0
40.0			38.8m/7.3	5.7			7.0	41.2m/5.3		38.1m/7.1	6.9			7.4	6.8				7.5	6.7			40.0
42.0				5.4				41.7m/6.5	5.2		6.4	43.4m/4.7		41.0m/6.2	6.3				7.1	6.3			42.0
44.0				5.1				5.0			6.0	4.7			6.0	45.5m/4.3			5.4	5.9			44.0
46.0				44.9m/4.8				4.7			44.6m/5.9	4.5			5.6	4.3				5.5	4.7m/4.0		46.0
48.0								47.8m/4.4				4.3			47.6m/5.3	4.2				5.2	4.0		48.0
50.0												4.0				3.9				4.9	3.8		50.0
52.0												50.8m/3.9				3.7				50.5m/4.8	3.6		52.0
54.0																53.7m/3.5					3.4		54.0
56.0																					3.2		56.0
58.0																					56.6m/3.1		58.0
Reeves	2	2	2	2	2	2	2	2	2	2	2	2	2	2	2	2	2	2	2	2	2	2	Reeves

Note:

Ratings according to Japanese Construction Codes for Mobile Cranes and Japanese Safety Ordinance on Cranes, etc.

Ratings shown in are determined by the strength of the tower or other structural components.

Lifting capacities may vary depending on hook used or with/without auxiliary sheave.

Please refer rated chart in operator's cabin.

LIFTING CAPACITIES



Tower Jib Lifting Capacities

Counterweight: 53.1 t

Unit: metric ton

42.5 m Tower Length	Tower length (m)	42.5												Tower length (m)
	Jib length (m)	22.9				25.9				29.0				Jib length (m)
	Tower angle	90°	80°	70°	60°	90°	80°	70°	60°	90°	80°	70°	60°	Tower angle
Working radius (m)	9.4	20.0												9.4
	10.0	20.0				10.2m/20.0				11.0m/20.0				10.0
	12.0	20.0				20.0				20.0				12.0
	14.0	20.0				20.0				20.0				14.0
	15.0	20.0				20.0				20.0				15.0
	16.0	18.7				18.7				18.7				16.0
	18.0	16.6				16.6				16.6				18.0
	20.0	15.0	20.5m/14.6			15.0	21.8m/13.7			15.0				20.0
	22.0	13.6	13.6			13.6	13.6			13.6	23.1m/12.9			22.0
	24.0	10.3	12.5			12.5	12.5			12.5	12.5			24.0
	26.0	25.4m/7.5	11.5			9.9	11.5			11.3	11.5			26.0
	28.0		10.7			7.1	10.7			9.3	10.7			28.0
	30.0		10.0	31.0m/9.5		28.3m/6.4	10.0			7.2	10.0			30.0
	32.0		9.3	9.0			9.3	32.7m/8.7		31.2m/5.5	9.3			32.0
	34.0		32.7m/9.1	8.4			8.8	8.2			8.8	34.5m/8.0		34.0
	36.0			7.8			35.7m/8.2	7.7			8.3	7.5		36.0
	38.0			7.3				7.2			7.8	7.1		38.0
	40.0			39.8m/6.8	40.6m/5.2			6.7			38.6m/7.1	6.6		40.0
	42.0				5.0			6.3	42.8m/4.6			6.2		42.0
	44.0				4.7			42.7m/6.1	4.5			5.8	44.9m/4.2	44.0
46.0				4.4				4.3			45.7m/5.4	4.1	46.0	
48.0				46.4m/4.3				4.1				3.9	48.0	
50.0								49.3m/3.9				3.7	50.0	
52.0												3.5	52.0	
54.0												52.3m/3.4	54.0	
Reeves	2	2	2	2	2	2	2	2	2	2	2	2	Reeves	

42.5 m Tower Length	Tower length (m)	42.5												Tower length (m)
	Jib length (m)	32.0				35.1				38.1				Jib length (m)
	Tower angle	90°	80°	70°	60°	90°	80°	70°	60°	90°	80°	70°	60°	Tower angle
Working radius (m)	10.0	11.8m/20.0												10.0
	12.0	20.0				12.5m/16.5				13.3m/13.6				12.0
	14.0	19.5				16.2				13.6				14.0
	15.0	19.0				16.0				13.4				15.0
	16.0	18.5				15.7				13.1				16.0
	18.0	16.6				15.3				12.7				18.0
	20.0	15.0				14.8				12.3				20.0
	22.0	13.6				13.6				11.9				22.0
	24.0	12.5	24.4m/12.2			12.5	25.6m/11.7			11.6				24.0
	26.0	11.5	11.5			11.5	11.5			11.2	26.9m/11.1			26.0
	28.0	10.3	10.7			10.7	10.7			10.5	10.7			28.0
	30.0	8.7	10.0			9.4	10.0			9.6	10.0			30.0
	32.0	7.0	9.3			8.0	9.3			8.5	9.3			32.0
	34.0	5.1	8.8			6.7	8.8			7.4	8.8			34.0
	36.0	34.2m/4.7	8.3	36.2m/7.4		5.3	8.3			6.3	8.3			36.0
	38.0		7.8	6.8		37.1m/4.1	7.8	6.8		5.1	7.8	39.7m/6.3		38.0
	40.0		7.5	6.5			7.5	6.4		3.7	7.5	6.1		40.0
	42.0		41.5m/6.2	6.1			7.1	6.0		40.1m/3.5	7.1	5.9		42.0
	44.0			5.7			6.1	5.6			6.7	5.5		44.0
	46.0			5.4	47.1m/3.8		44.5m/5.4	5.3			5.9	5.2		46.0
48.0			5.0	3.7			5.0	49.2m/3.4		47.4m/4.7	4.9		48.0	
50.0			48.6m/4.9	3.6			4.7	3.4			4.6	51.4m/3.2	50.0	
52.0				3.4			51.6m/4.4	3.3			4.3	3.1	52.0	
54.0				3.2				3.1			4.1	3.0	54.0	
56.0				55.2m/3.0				2.9			54.5m/3.8	2.8	56.0	
58.0								2.8				2.6	58.0	
60.0								58.2m/2.7				2.5	60.0	
62.0												61.1m/2.4	62.0	
Reeves	2	2	2	2	2	2	2	2	2	2	2	2	Reeves	

Note:

Ratings according to Japanese Construction Codes for Mobile Cranes and Japanese Safety Ordinance on Cranes, etc.

Ratings shown in are determined by the strength of the tower or other structural components.

Lifting capacities may vary depending on hook used or with/without auxiliary sheave.

Please refer rated chart in operator's cabin.



Tower Jib Lifting Capacities

Counterweight: 53.1 t

Unit: metric ton

45.6 m Tower Length	45.6																	
	22.9				25.9				29.0				32.0					
	Tower angle	90°	80°	70°	60°	90°	80°	70°	60°	90°	80°	70°	60°	90°	80°	70°	60°	Tower angle
9.4	20.0																	9.4
10.0	20.0				10.2m/20.0				11.0m/20.0				11.8m/20.0					10.0
12.0	20.0				20.0				20.0				20.0					12.0
14.0	20.0				20.0				20.0				19.5					14.0
15.0	20.0				20.0				20.0				19.0					15.0
16.0	18.7				18.7				18.7				18.5					16.0
18.0	16.6				16.6				16.6				16.6					18.0
20.0	15.0	21.0m/14.2			15.0				15.0				15.0					20.0
22.0	13.6	13.6			13.6	22.3m/13.4			13.6	23.6m/12.7			13.6					22.0
24.0	10.3	12.5			12.5	12.5			12.5	12.5			12.5	24.9m/12.0				24.0
26.0	25.4m/7.5	11.5			9.9	11.5			11.3	11.5			11.5	11.5				26.0
28.0		10.7			7.1	10.7			9.3	10.7			10.3	10.7				28.0
30.0		10.0			28.3m/6.4	10.0			7.2	10.0			8.7	10.0				30.0
32.0		9.3	8.7			9.3	33.8m/8.0		31.2m/5.5	9.3			7.0	9.3				32.0
34.0		33.2m/9.0	8.0			8.8	7.8			8.8	35.5m/7.4		5.2	8.8				34.0
36.0			7.5			8.3	7.4			8.3	7.1		34.2m/4.8	8.3	37.3m/6.8			36.0
38.0			7.0			36.2m/8.2	6.9			7.8	6.8			7.8	6.5			38.0
40.0			6.5				6.4			39.1m/7.1	6.3			7.5	6.2			40.0
42.0			40.8m/6.3	42.1m/4.4			6.0				5.9			6.5	5.8			42.0
44.0				4.3			43.8m/5.6	44.3m/4.0			5.5			42.1m/6.2	5.5			44.0
46.0				4.1				3.9			5.2	46.4m/3.6			5.1			46.0
48.0				47.9m/3.9				3.7			46.7m/5.0	3.5			4.8	48.6m/3.3		48.0
50.0								3.5				3.4			49.7m/4.4	3.2		50.0
52.0								50.9m/3.4				3.2				3.1		52.0
54.0												53.8m/3.0				2.9		54.0
56.0																2.7		56.0
58.0																56.7m/2.6		58.0
Reeves	2	2	2	2	2	2	2	2	2	2	2	2	2	2	2	2	2	Reeves

45.6 m Tower Length	45.6																
	35.1				38.1				41.1								
	Tower angle	90°	80°	70°	60°	90°	80°	70°	60°	90°	80°	70°	Tower angle				
12.0	12.5m/16.5				13.3m/13.6							12.0					
14.0	16.2				13.6				14.1m/10.7			14.0					
15.0	16.0				13.3				10.7			15.0					
16.0	15.7				13.1				10.5			16.0					
18.0	15.2				12.7				10.2			18.0					
20.0	14.8				12.3				9.8			20.0					
22.0	13.6				11.9				9.5			22.0					
24.0	12.5				11.6				9.2			24.0					
26.0	11.5	26.2m/11.4			11.1	27.5m/10.9			8.9			26.0					
28.0	10.7	10.7			10.5	10.7			8.6	28.7m/9.8		28.0					
30.0	9.4	10.0			9.6	10.0			8.3	9.6		30.0					
32.0	8.1	9.3			8.5	9.3			7.8	9.3		32.0					
34.0	6.7	8.8			7.4	8.8			7.3	8.8		34.0					
36.0	5.3	8.3			6.3	8.3			6.8	8.3		36.0					
38.0	37.1m/4.1	7.8	39.0m/6.3		5.1	7.8			6.2	7.8		38.0					
40.0		7.5	6.0		3.8	7.5	40.8m/5.7		5.2	7.5		40.0					
42.0		7.1	5.7		40.1m/3.5	7.1	5.4		4.1	7.1	42.5m/5.4	42.0					
44.0		6.8	5.4			6.7	5.2		43.0m/3.2	6.6	5.0	44.0					
46.0		45.0m/5.4	5.1			6.2	4.9			6.2	4.8	46.0					
48.0			4.8			4.7	4.6			5.8	4.5	48.0					
50.0			4.5	50.7m/3.0			4.4			5.2	4.3	50.0					
52.0			4.2	2.9			4.1	52.9m/2.7		50.9m/4.3	4.0	52.0					
54.0			52.6m/3.9	2.8			3.9	2.6			3.8	54.0					
56.0				2.7			55.6m/3.4	2.5			3.5	56.0					
58.0				2.5				2.4			3.3	58.0					
60.0				59.7m/2.3				2.2			58.5m/3.1	60.0					
62.0								2.1				62.0					
64.0								62.6m/2.0				64.0					
Reeves	2	2	2	2	2	2	2	2	2	2	2	Reeves					

Note:

Ratings according to Japanese Construction Codes for Mobile Cranes and Japanese Safety Ordinance on Cranes, etc. Ratings shown in are determined by the strength of the tower or other structural components. Lifting capacities may vary depending on hook used or with/without auxiliary sheave. Please refer rated chart in operator's cabin.

LIFTING CAPACITIES



Tower Jib Lifting Capacities

Counterweight: 53.1 t

Unit: metric ton

48.6 m Tower Length	48.6																	
	22.9				25.9				29.0				32.0				Tower length (m)	
	Tower angle	90°	80°	70°	60°	90°	80°	70°	60°	90°	80°	70°	60°	90°	80°	70°	60°	Jib length (m)
Working radius (m)	9.4	20.0																9.4
	10.0	20.0				10.2m/20.0			11.0m/20.0				11.8m/19.9					10.0
	12.0	20.0				20.0			20.0				19.9					12.0
	14.0	20.0				20.0			19.5				18.6					14.0
	15.0	20.0				19.8			18.9				18.0					15.0
	16.0	18.7				18.7			18.3				17.5					16.0
	18.0	16.6				16.6			16.6				16.5					18.0
	20.0	15.0	21.5m/13.9			15.0			15.0				15.0					20.0
	22.0	13.6	13.6			13.6	22.8m/13.1			13.6			13.6					22.0
	24.0	10.4	12.5			12.5	12.5			12.5	24.1m/12.4		12.5	25.4m/11.8				24.0
	26.0	25.4m/7.5	11.5			10.0	11.5			11.4	11.5		11.5	11.5				26.0
	28.0		10.7			7.1	10.7			9.4	10.7		10.3	10.7				28.0
	30.0		10.0			28.3m/6.4	10.0			7.3	10.0		8.7	10.0				30.0
	32.0		9.3	33.1m/8.0			9.3			31.2m/5.5	9.3		7.1	9.3				32.0
	34.0		33.8m/8.8	7.6			8.8	34.8m/7.4			8.8		5.2	8.8				34.0
	36.0			7.2			8.3	6.9			8.3	36.6m/6.8	34.2m/4.8	8.3				36.0
	38.0			6.7			36.7m/8.1	6.6			7.8	6.3		7.8	38.3m/6.2			38.0
	40.0			6.3				6.2			39.7m/7.1	6.0		7.3	5.8			40.0
	42.0			41.9m/5.8	43.7m/3.8			5.8				5.6		6.7	5.5			42.0
	44.0				3.8			5.4	45.8m/3.4			5.3		42.6m/6.2	5.2			44.0
	46.0				3.7			44.8m/5.2	3.4			5.0			4.9			46.0
48.0				3.4				3.3			47.8m/4.5	3.1		4.6			48.0	
50.0				49.4m/3.1				3.1				3.0		4.3	50.1m/2.7		50.0	
52.0								2.9				2.8		50.7m/4.0	2.6		52.0	
54.0								52.4m/2.8				2.6			2.5		54.0	
56.0												55.3m/2.4			2.4		56.0	
58.0															2.2		58.0	
60.0															58.3m/2.1		60.0	
Reeves	2	2	2	2	2	2	2	2	2	2	2	2	2	2	2	2	2	Reeves

48.6 m Tower Length	48.6														
	35.1				38.1				41.1				44.2		Tower length (m)
	Tower angle	90°	80°	70°	60°	90°	80°	70°	90°	80°	70°	90°	80°	70°	Jib length (m)
Working radius (m)	12.0	12.5m/16.5				13.3m/13.6								12.0	
	14.0	16.2				13.6			14.1m/10.7			14.9m/9.1		14.0	
	15.0	15.9				13.3			10.7			9.1		15.0	
	16.0	15.7				13.1			10.5			8.9		16.0	
	18.0	15.2				12.7			10.1			8.6		18.0	
	20.0	14.8				12.3			9.8			8.3		20.0	
	22.0	13.6				11.9			9.5			8.0		22.0	
	24.0	12.5				11.5			9.2			7.7		24.0	
	26.0	11.5	26.7m/11.2			11.1			8.9			7.4		26.0	
	28.0	10.7	10.7			10.5	10.7		8.6	29.3m/9.8		7.2		28.0	
	30.0	9.4	10.0			9.6	10.0		8.3	9.6		6.9	30.6m/8.0	30.0	
	32.0	8.1	9.3			8.5	9.3		7.8	9.2		6.7	7.8	32.0	
	34.0	6.7	8.8			7.4	8.8		7.3	8.8		6.4	7.6	34.0	
	36.0	5.3	8.3			6.3	8.3		6.8	8.3		6.0	7.3	36.0	
	38.0	37.1m/4.1	7.8			5.1	7.8		6.2	7.8		5.6	7.1	38.0	
	40.0		7.5	40.1m/5.7		3.8	7.5	41.8m/5.2	5.2	7.3		5.2	6.9	40.0	
	42.0		7.1	5.3		40.1m/3.5	6.9	5.2	4.1	6.8	43.6m/4.8	4.8	6.7	42.0	
	44.0		6.5	5.1			6.5	5.0	43.0m/3.2	6.4	4.7	4.0	6.2	45.3m/4.4	44.0
	46.0		45.6m/5.4	4.8			6.0	4.7		5.9	4.6	2.8	5.8	4.3	46.0
	48.0			4.5			5.5	4.4		5.5	4.3		5.5	4.1	48.0
	50.0			4.2			48.5m/4.7	4.1		5.1	4.0		5.1	3.9	50.0
52.0			4.0	52.3m/2.4			3.8		51.4m/4.3	3.7		4.7	3.6	52.0	
54.0			53.7m/3.5	2.3			3.6			3.5		4.3	3.4	54.0	
56.0				2.2			3.4			3.3		54.4m/3.8	3.1	56.0	
58.0				2.1			56.6m/3.3			3.0			2.9	58.0	
60.0				2.0						59.6m/2.8			2.7	60.0	
62.0													2.5	62.0	
64.0													62.5m/2.4	64.0	
Reeves	2	2	2	2	2	2	2	2	2	2	2	2	2	Reeves	

Note:

Ratings according to Japanese Construction Codes for Mobile Cranes and Japanese Safety Ordinance on Cranes, etc.

Ratings shown in are determined by the strength of the tower or other structural components.

Lifting capacities may vary depending on hook used or with/without auxiliary sheave.

Please refer rated chart in operator's cabin.



Tower Jib Lifting Capacities

Counterweight: 53.1 t

Unit: metric ton

51.7 m Tower Length	51.7																	
	22.9				25.9				29.0				32.0					
	Tower angle	90°	80°	70°	60°	90°	80°	70°	60°	90°	80°	70°	60°	90°	80°	70°	60°	Tower angle
9.4	20.0																	9.4
10.0	20.0				10.2m/20.0				11.0m/20.0				11.8m/18.6					10.0
12.0	20.0				20.0				19.4				18.6					12.0
14.0	20.0				19.2				18.2				17.4					14.0
15.0	20.0				18.6				17.7				16.8					15.0
16.0	18.7				18.1				17.2				16.4					16.0
18.0	16.6				16.6				16.3				15.5					18.0
20.0	15.0				15.0				15.0				14.7					20.0
22.0	13.6	22.1m/13.5			13.6	23.4m/12.8			13.6				13.6					22.0
24.0	10.4	12.5			12.5	12.5			12.5	24.7m/12.1			12.5	25.9m/11.5				24.0
26.0	25.4m/7.6	11.5			10.0	11.5			11.4	11.5			11.5	11.5				26.0
28.0		10.7			7.2	10.7			9.4	10.7			10.3	10.7				28.0
30.0		10.0			28.3m/6.5	10.0			7.3	10.0			8.7	10.0				30.0
32.0		9.3				9.3			31.2m/5.5	9.3			7.1	9.3				32.0
34.0		8.8	34.1m/7.3			8.8	35.9m/6.6			8.8			5.2	8.8				34.0
36.0		34.3m/8.7	6.7			8.3	6.5			8.3	37.6m/6.0		34.2m/4.8	8.3				36.0
38.0			6.3			37.3m/8.2	6.2			7.6	5.9			7.8	39.4m/5.4			38.0
40.0			5.9				5.8			6.9	5.7			7.4	5.4			40.0
42.0			5.5				5.4			40.2m/6.8	5.3			6.8	5.2			42.0
44.0			42.9m/5.2	45.2m/3.3			5.1				5.0			43.1m/6.2	4.9			44.0
46.0				3.2			45.9m/4.8	47.3m/3.0			4.7				4.6			46.0
48.0				3.1				2.9			4.4	49.5m/2.6			4.3			48.0
50.0				2.9				2.8			48.8m/4.2	2.6		4.0	51.6m/2.2			50.0
52.0				51.0m/2.8				2.6				2.5			51.8m/3.7	2.2		52.0
54.0								53.9m/2.4				2.3				2.1		54.0
56.0												2.1				2.0		56.0
58.0												56.8m/2.0						58.0
Reeves	2	2	2	2	2	2	2	2	2	2	2	2	2	2	2	2	2	Reeves

51.7 m Tower Length	51.7												
	35.1			38.1			41.1			44.2			
	Tower angle	90°	80°	70°	90°	80°	70°	90°	80°	70°	90°	80°	70°
12.0	12.5m/16.5			13.3m/13.6									12.0
14.0	16.2			13.6			14.1m/10.7			14.9m/9.1			14.0
15.0	15.9			13.3			10.7			9.1			15.0
16.0	15.6			13.1			10.5			8.9			16.0
18.0	14.7			12.6			10.1			8.6			18.0
20.0	14.0			12.2			9.8			8.3			20.0
22.0	13.4			11.9			9.5			8.0			22.0
24.0	12.5			11.5			9.1			7.7			24.0
26.0	11.5	27.2m/10.7		11.1			8.9			7.4			26.0
28.0	10.7	10.3		10.4	28.5m/10.0		8.6	29.8m/8.5		7.1			28.0
30.0	9.4	9.9		9.6	9.1		8.3	8.5		6.9	31.1m/8.0		30.0
32.0	8.1	9.3		8.5	8.8		7.8	8.2		6.7	7.6		32.0
34.0	6.8	8.8		7.4	8.5		7.3	7.9		6.4	7.3		34.0
36.0	5.3	8.3		6.3	8.2		6.8	7.6		6.0	7.1		36.0
38.0	37.1m/4.2	7.8		5.2	7.7		6.3	7.4		5.6	6.8		38.0
40.0		7.3	41.1m/4.9	3.8	7.1		5.2	7.0		5.2	6.6		40.0
42.0		6.8	4.9	40.1m/3.5	6.6	42.9m/4.4	4.1	6.5		4.8	6.4		42.0
44.0		6.3	4.8		6.2	4.4	43.0m/3.2	6.1	44.6m/4.2	4.0	5.9		44.0
46.0		5.7	4.5		5.7	4.3		5.7	4.0	2.8	5.5	46.4m/3.8	46.0
48.0		46.1m/5.4	4.2		5.3	4.0		5.3	3.8		5.2	3.6	48.0
50.0			3.9		49.0m/4.7	3.7		4.9	3.6		4.8	3.4	50.0
52.0			3.6			3.5		4.3	3.3		4.5	3.2	52.0
54.0			3.4			3.2			3.1		4.2	3.0	54.0
56.0			54.7m/3.3			3.0			2.9		54.9m/3.8	2.8	56.0
58.0						57.6m/2.8			2.7			2.6	58.0
60.0									2.5			2.4	60.0
62.0									60.6m/2.4			2.2	62.0
64.0												63.5m/2.0	64.0
Reeves	2	2	2	2	2	2	1	1	1	1	1	1	Reeves

Note:

Ratings according to Japanese Construction Codes for Mobile Cranes and Japanese Safety Ordinance on Cranes, etc.

Ratings shown in are determined by the strength of the tower or other structural components.

Lifting capacities may vary depending on hook used or with/without auxiliary sheave.

Please refer rated chart in operator's cabin.

GENERAL DIMENSION FOR CLAMSHELL

Clamshell Specification

(Unit: mm)

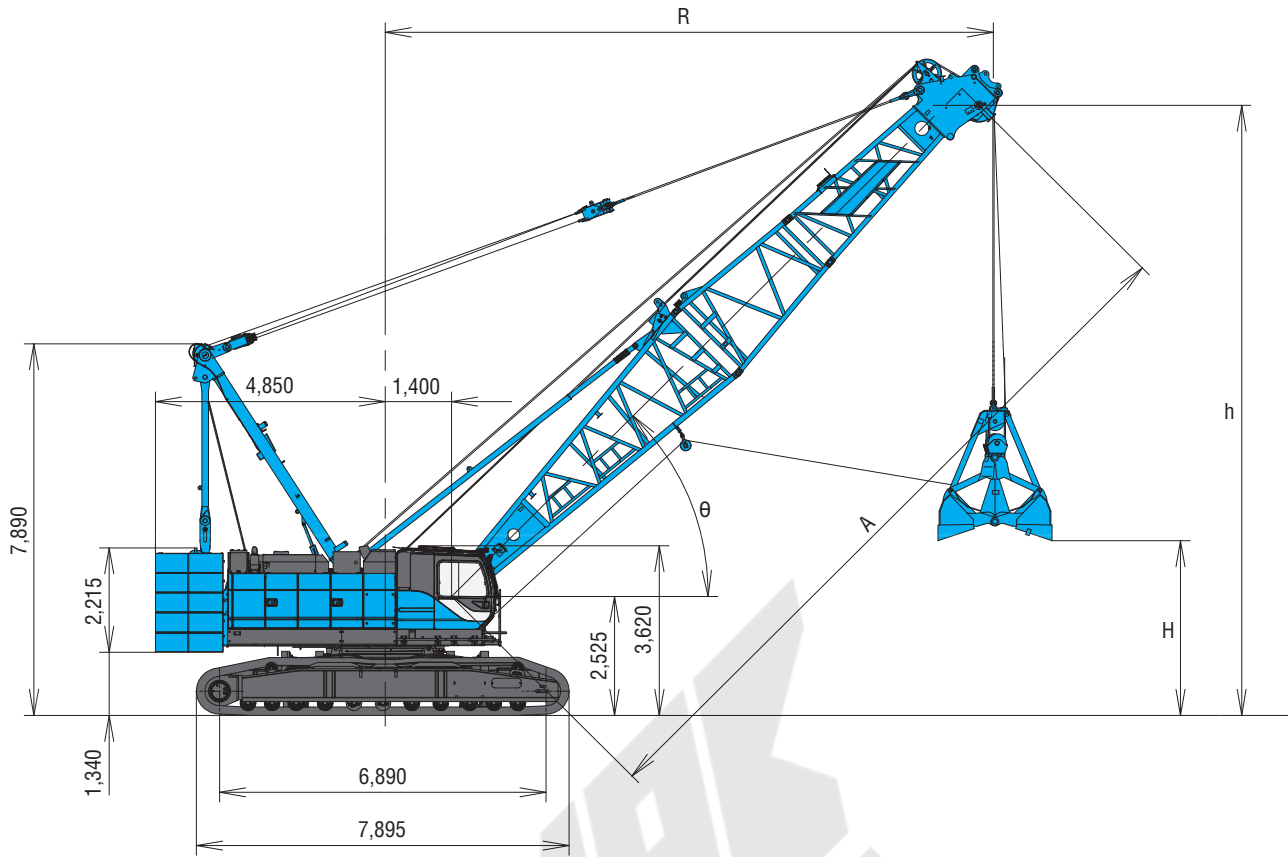

Boom length	m	A	15.2					18.3					21.3				
Boom angle	deg.	θ	38	45	55	65	72	40	45	55	65	71	42	45	55	65	68
Load radius	m	R	14.0	12.8	10.9	8.6	7.0	16.0	15.0	12.6	9.9	8.0	18.0	17.1	14.4	11.2	10.0
Bucket capacity	2.0 m ³	H	2.6	4.0	5.8	7.2	7.9	7.5	8.7	10.8	12.5	13.3	9.9	10.9	13.3	15.3	15.8
	2.5 m ³		2.2	3.6	5.4	6.8	7.5	7.1	8.3	10.4	12.1	12.9	9.5	10.5	12.9	14.9	15.4
	3.0 m ³		2.0	3.4	5.2	6.6	7.3	6.9	8.1	10.2	11.9	12.7	9.3	10.3	12.7	14.7	15.2
	4.0 m ³		1.8	3.2	5.0	6.4	7.1	6.7	7.9	10.0	11.7	12.5	9.1	10.1	12.5	14.5	15.0
Boom point height	m	h	11.5	12.9	14.7	16.1	16.8	13.9	15.1	17.2	18.9	19.7	16.3	17.3	19.7	21.7	22.2
Rated load	t	t	10.0														

Boom length	m	A	24.4					27.4				
Boom angle	deg.	θ	43	45	55	65	66	43	45	55	65	69
Load radius	m	R	20.0	19.3	16.1	12.5	12.0	22.0	21.5	17.9	13.8	12.0
Bucket capacity	2.0 m ³	H	12.3	13.0	15.8	18.0	18.2	14.6	15.2	18.3	20.8	21.6
	2.5 m ³		11.9	12.6	15.4	17.6	17.8	14.2	14.8	17.9	20.4	21.2
	3.0 m ³		11.7	12.4	15.2	17.4	17.6	14.0	14.6	17.7	20.2	21.0
	4.0 m ³		11.5	12.2	15.0	17.2	17.4	13.8	14.4	17.5	20.0	20.8
Boom point height	m	h	18.7	19.4	22.2	24.4	24.6	21.0	21.6	24.7	27.2	28.0
Rated load	t	t	10.0									

WORKING RANGE FOR CLAMSHELL

Clamshell Working Range

Unit: m

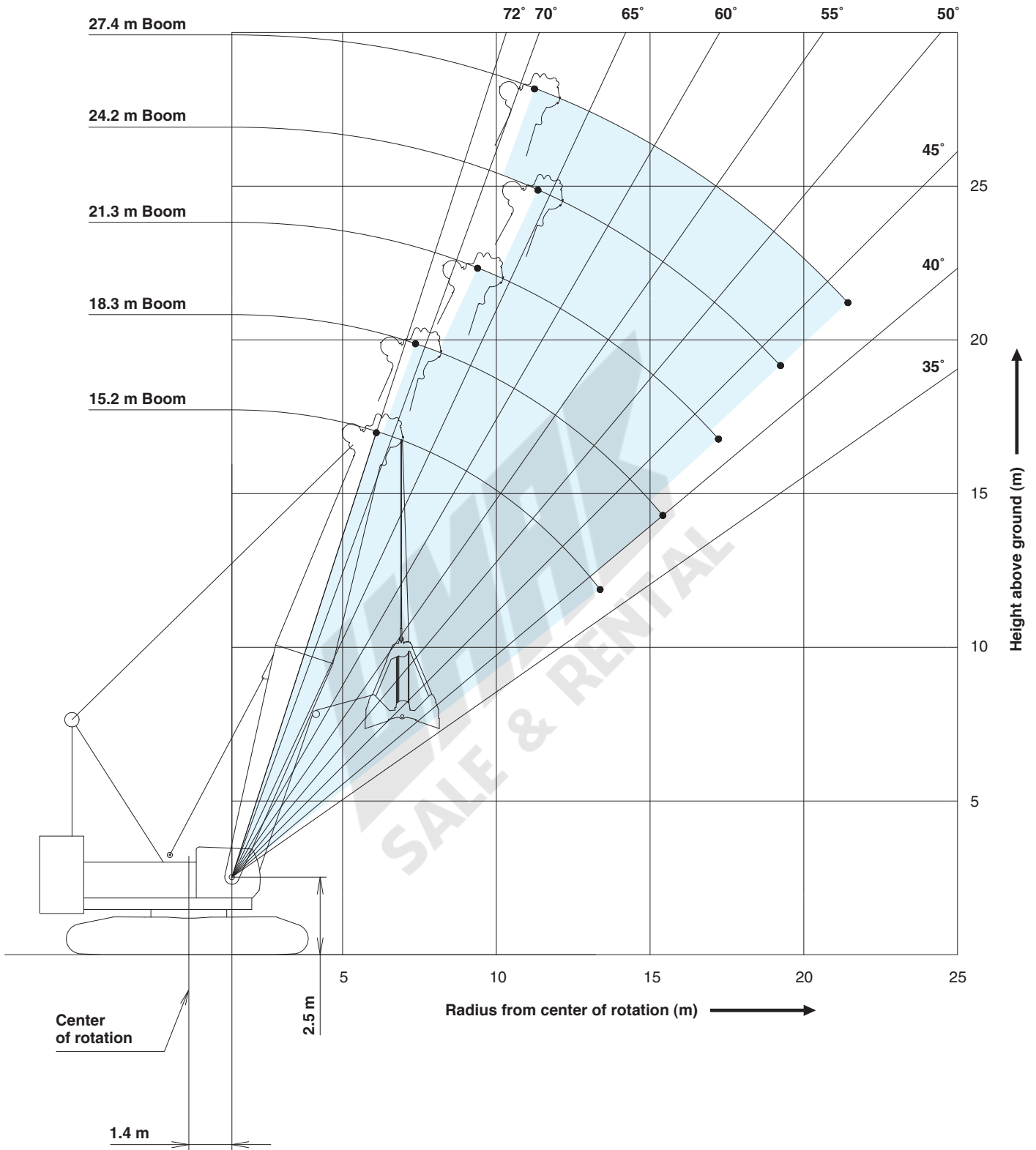

- Operating radius is the horizontal distance from centerline of rotation to a vertical line through the center of gravity of the load.
- Deduct weight of bucket, slings and all other load handling accessories from main boom ratings shown.
- Ratings shown are based on freely suspended loads and make no allowance for such factors as wind effect on lifted load, ground conditions, out-of-level, operating speeds or any other condition that could be detrimental to the safe operation of this equipment. The operator, therefore, has the responsibility to judge the existing conditions and reduce lifted loads and operating speeds accordingly.
- Rated loads do not exceed 66% of minimum tipping loads.
- Ratings are for operation on a firm and level surface, up to 1% gradient.
- At radii and boom lengths where no ratings are shown on chart, operation is not intended nor approved.
- Boom inserts and guy lines must be arranged as shown in the "Operator's Manual".
- Boom hoist reeving is 12 part line.
- Gantry must be in raised position for all conditions.
- Boom backstops are required for all boom lengths.
- The boom should be erected over the front of the crawlers, not laterally.

(Clamshell bucket lifting)

- The total load that can be lifted is the value for weight of bucket, slings, and all other load handling accessories deducted from main boom ratings shown.
- The weight of bucket and materials must not exceed rated load.
- Optimum bucket should be required according to material. $\text{Bucket capacity (m}^3\text{)} \times \text{specified gravity of material (ton/m}^3\text{)} + \text{bucket weight (ton)} = \text{rated load}$.
- Bucket weight must also be decreased according to operating cycle and bucket lowering height.
- Rated loads are determined by stability and boom strength. During simultaneous operations of boom and swing, rapid acceleration or deceleration must be avoided.
- Do not attempt to cast the bucket while swinging or diagonal draw-cutting.

<Reference Information>

Main hoist loads

No. of Parts of Line	1
Maximum Loads (kN)	98
Maximum Loads (t)	10.0

Assembling the counterweight

45.1 ton counterweight

No.6	No.7
No.4	No.5
No.3	
No.2	
No.1	

Counterweights

Operation of this equipment in excess of rated loads or disregard of instruction voids the warranty.

LIFTING CAPACITIES FOR CLAMSHELL



Clamshell Bucket Specification

Bucket capacity (m ³)	Bucket height when opened (m)
2.0	3.9
2.5	4.3
3.0	4.5
4.0	4.7



Clamshell Rating Charts Crane Boom Capacities

Counterweight: 45.1 t

Unit: metric ton

Working radius (m)	Boom length (m)	Counterweight: 45.1 t					Boom length (m)	Working radius (m)
		15.2	18.3	21.3	24.4	27.4		
7.0	10.0						7.0	
8.0	10.0	10.0					8.0	
9.0	10.0	10.0	10.0				9.0	
10.0	10.0	10.0	10.0	10.0			10.0	
12.0	10.0	10.0	10.0	10.0	10.0	10.0	12.0	
14.0	10.0	10.0	10.0	10.0	10.0	10.0	14.0	
16.0		10.0	10.0	10.0	10.0	10.0	16.0	
18.0			10.0	10.0	10.0	10.0	18.0	
20.0				10.0	10.0	10.0	20.0	
22.0					10.0	10.0	22.0	
Reeves		1	1	1	1	1	Reeves	

Note:
Please refer rated chart in operator's cabin.



SUPPLEMENTAL DATA FOR REDUCED WEIGHTS RATING CHART

- Ratings according to Japanese Construction Codes for Mobile Cranes.
- Operating radius is the horizontal distance from centerline of rotation to a vertical line through the center of gravity of the load.
- Deduct weight of hook block (s), slings and all other load handling accessories from main boom ratings shown.
- Ratings shown are based on freely suspended loads and make no allowance for such factors as wind effect on lifted load, ground conditions, out-of-level, operating speeds or any other condition that could be detrimental to the safe operation of this equipment. The operator, therefore, has the responsibility to judge the existing conditions and reduce lifted loads and operating speeds accordingly.
- Ratings are for operation on a firm and level surface, up to 1% gradient.
- At radii and boom lengths where no ratings are shown on chart, operation is not intended nor approved.
- Boom inserts and guy lines must be arranged as shown in the "Operator's Manual".
- Boom hoist reeving is 12 part line.
- Gantry must be in raised position for all conditions.
- Boom backstops are required for all boom lengths.
- The boom should be erected over the front of the crawlers, not laterally.
- Ratings inside of boxes are limited by strength of materials.
- The minimum rated load is 2.0 (ton).
- Crawler frames must be fully extended for all crane operations.

(Crane boom lifting)

- The total load that can be lifted is the value for weight of hook block, slings, and all other load handling accessories deducted from main boom ratings shown.

<Reference Information>

Main hoist loads

No. of Parts of Line	1	2	3	4	5
Maximum Loads (kN)	118	235	353	471	588
Maximum Loads (t)	12.0	24.0	36.0	48.0	60.0

No. of Parts of Line	6	7	8	9	10
Maximum Loads (kN)	706	824	941	1,059	1,177
Maximum Loads (t)	72.0	84.0	96.0	108.0	120.0

Auxiliary hoist loads

No. of Parts of Line	1
Maximum Loads (kN)	118
Maximum Loads (t)	12.0

Weight of hook block				
Hook Block	120 t	70 t	35 t	Ball Hook
Weight (t)	1.7	1.2	0.9	0.45

Assembling the counterweight

45.1 ton counterweight

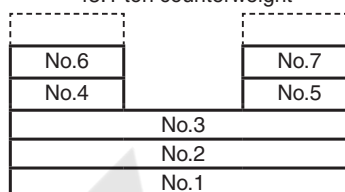

Counterweights

- The lifting capacity does not change due to the type of counterweights.

Operation of this equipment in excess of rated loads or disregard of instruction voids the warranty.

LIFTING CAPACITIES FOR REDUCED WEIGHTS



Reduced Weights Rating Charts Crane Boom Lifting Capacities

Counterweight: 45.1 t

Unit: metric ton

Working radius (m)	Boom length (m)	15.2	18.3	21.3	24.4	27.4	30.5	33.5	36.6	Boom length (m)	Working radius (m)
		4.5	4.5m/120.0								
5.0	120.0	5.1m/108.0	5.6m/96.0							5.0	
6.0	100.0	99.8	94.9	6.1m/84.0	6.7m/74.6					6.0	
7.0	78.8	78.7	78.6	78.6	73.7	7.2m/66.4	7.7m/59.4			7.0	
8.0	63.2	63.1	63.0	63.0	62.8	62.8	58.9	8.2m/53.6		8.0	
9.0	52.7	52.5	52.4	52.4	52.2	52.2	52.1	52.0		9.0	
10.0	45.0	44.9	44.8	44.7	44.5	44.5	44.4	44.3		10.0	
12.0	34.8	34.6	34.4	34.4	34.2	34.1	34.1	33.9		12.0	
14.0	28.2	28.0	27.8	27.7	27.5	27.5	27.4	27.2		14.0	
16.0	14.9m/25.9	23.4	23.2	23.1	22.9	22.8	22.7	22.5		16.0	
18.0		17.5m/20.8	19.8	19.7	19.5	19.4	19.3	19.1		18.0	
20.0			17.2	17.1	16.9	16.8	16.7	16.5		20.0	
22.0			20.1m/17.2	15.1	14.8	14.7	14.6	14.4		22.0	
24.0				22.8m/14.4	13.2	13.1	12.9	12.7		24.0	
26.0					25.4m/12.2	11.7	11.6	11.3		26.0	
28.0						28.0m/10.5	10.4	10.2		28.0	
30.0							9.4	9.2		30.0	
32.0							30.7m/9.1	8.4		32.0	
34.0								33.3m/7.9		34.0	
Reeves	10	9	8	7	7	6	5	5	Reeves		

Working radius (m)	Boom length (m)	39.6	42.7	45.7	48.8	51.8	54.9	57.9	61.0	Boom length (m)	Working radius (m)
		8.0	8.8m/48.0								
9.0	48.0	9.3m/43.5	9.8m/39.6							9.0	
10.0	44.2	42.8	39.5	10.4m/36.0	10.9m/32.1	11.4m/29.4				10.0	
12.0	33.8	33.7	33.5	33.5	31.4	29.0	12.0m/26.9	12.5m/24.0		12.0	
14.0	27.1	27.0	26.8	26.8	26.7	26.5	25.9	23.5		14.0	
16.0	22.5	22.3	22.2	22.1	22.0	21.8	21.6	21.6		16.0	
18.0	19.0	18.9	18.7	18.7	18.5	18.3	18.2	18.1		18.0	
20.0	16.4	16.3	16.1	16.0	15.9	15.7	15.5	15.5		20.0	
22.0	14.3	14.2	14.0	13.9	13.8	13.6	13.4	13.4		22.0	
24.0	12.6	12.5	12.3	12.2	12.1	11.9	11.7	11.6		24.0	
26.0	11.3	11.1	10.9	10.8	10.7	10.5	10.3	10.2		26.0	
28.0	10.1	9.9	9.7	9.7	9.5	9.3	9.1	9.1		28.0	
30.0	9.1	8.9	8.7	8.6	8.5	8.3	8.1	8.0		30.0	
32.0	8.2	8.1	7.9	7.8	7.6	7.4	7.3	7.2		32.0	
34.0	7.5	7.3	7.1	7.0	6.9	6.7	6.5	6.4		34.0	
36.0	36.0m/6.9	6.7	6.5	6.4	6.2	6.0	5.8	5.7		36.0	
38.0		6.1	5.9	5.8	5.6	5.4	5.3	5.1		38.0	
40.0		38.6m/6.0	5.4	5.3	5.1	4.9	4.7	4.6		40.0	
42.0			41.2m/5.1	4.8	4.6	4.4	4.2	4.1		42.0	
44.0				43.9m/4.4	4.2	4.0	3.8	3.7		44.0	
46.0					3.8	3.6	3.4	3.3		46.0	
48.0					46.5m/3.8	3.3	3.1	2.9		48.0	
50.0						49.2m/3.1	2.6	2.5		50.0	
52.0							51.8m/2.3	52.0m/2.1		52.0	
Reeves	4	4	4	3	3	3	3	2	Reeves		

Note:

Ratings according to Japanese Construction Codes for Mobile Cranes.

Ratings shown in are determined by the strength of the boom or other structural components.

Lifting capacities may vary depending on hook used or with/without auxiliary sheave.

Please refer rated chart in operator's cabin.

SUPPLEMENTAL DATA FOR BARGE RATING CHART

- Operating radius is the horizontal distance from centerline of rotation to a vertical line through the center of gravity of the load.
- Deduct weight of hook block (s), slings and all other load handling accessories from main boom ratings shown.
- Condition of barge stability this rating chart were determined under the condition below. The stability of barge shall meet below condition. During operation the machinery static inclination against horizontal level.
 - (A) Both sides (right & left) of machine
Maximum inclination shall be within 1.5 degrees
 - (B) Front & backward of machine
Maximum inclination shall be within 3.0 degrees

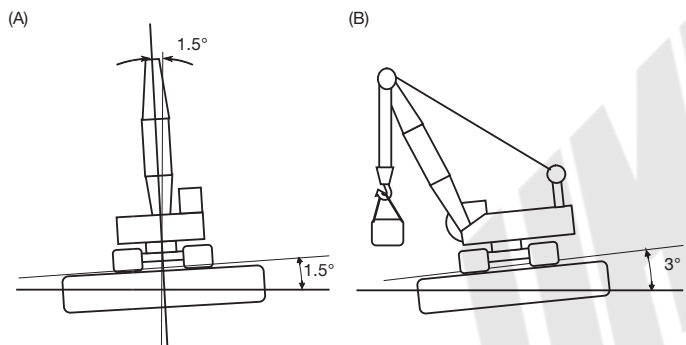
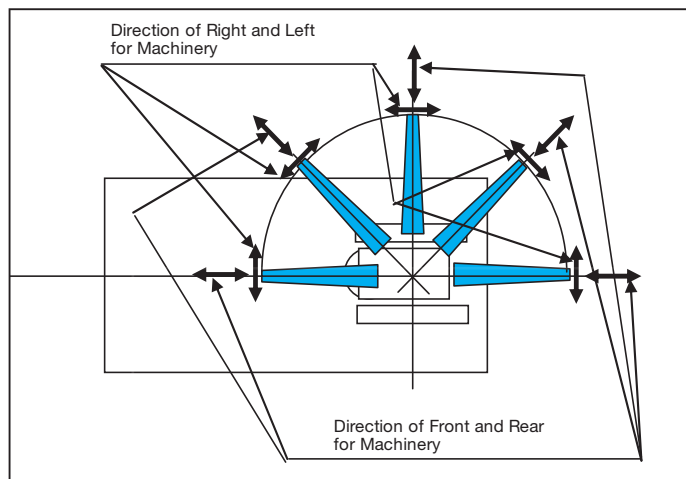

- Towing area
Towing area shall be within coastal area and quiet wave condition. Offshore and open sea is not considered for this machinery. Depend on the height of wave, counterweight shall be reduced during towing.

(Crane Boom)

- The total load that can be lifted is the value for weight of hook block, slings, and all other load handling accessories deducted from main boom ratings shown.

<Reference Information>

Main hoist loads

No. of Parts of Line	1	2	3	4	5
Maximum Loads (kN)	118	235	353	471	588
Maximum Loads (t)	12.0	24.0	36.0	48.0	60.0

No. of Parts of Line	6	7
Maximum Loads (kN)	706	785
Maximum Loads (t)	72.0	80.0

Auxiliary hoist loads

No. of Parts of Line	1
Maximum Loads (kN)	118
Maximum Loads (t)	12

Weight of hook block				
Hook Block	120 t	70 t	35 t	Ball Hook
Weight (t)	1.7	1.2	0.9	0.45

Operation of this equipment in excess of rated loads or disregard of instruction voids the warranty.

- Working area shall be inshore and smooth water.
- Applicable regulations for structure
- Japanese construction codes for mobile crane
 - ※ Regulation of class of shipping (abs, lloyd, bv, nk, etc) are not adapted.
- At radii and boom lengths where no ratings are shown on chart, operation is not intended nor approved.
- Boom inserts and guy lines must be arranged as shown in the "Operator's Manual".
- Boom hoist reeving is 12 part line.
- Gantry must be in raised position for all conditions.
- Boom backstops are required for all boom lengths.
- The boom should be erected over the front of the crawlers, not laterally.
- Ratings inside of boxes are limited by strength of materials.
- The minimum rated load is 2.0 (ton).
- The machinery should be fastened to the deck of the barge to prevent tip over and sliding.

LIFTING CAPACITIES FOR BARGE



Barge Rating Charts Crane Boom Lifting Capacities

Counterweight: 53.1 t

Unit: metric ton

Working radius (m)	Boom length (m)							Boom length (m)	Working radius (m)
		15.2	18.3	21.3	24.4	27.4	30.5		
5.0	5.3m/80.0								5.0
6.0	69.1	6.0m/66.8	6.7m/63.0						6.0
7.0	60.7	60.4	60.1	7.4m/56.6					7.0
8.0	52.7	52.4	52.1	51.9	8.1m/51.2	8.7m/46.7			8.0
9.0	46.5	46.3	46.0	45.8	45.5	45.4	9.4m/41.6		9.0
10.0	41.6	41.3	41.0	40.9	40.6	40.4	40.3		10.0
12.0	34.2	33.9	33.6	33.4	33.2	33.0	32.9		12.0
14.0	25.0	28.4	28.4	28.2	27.9	27.7	27.5		14.0
16.0	14.9m/21.3	22.6	23.8	24.2	23.9	23.8	23.6		16.0
18.0		17.5m/17.7	19.4	20.2	20.7	20.7	20.5		18.0
20.0			15.1	16.7	17.2	18.2	17.8		20.0
22.0			20.1m/14.8	14.0	14.5	15.3	15.7		22.0
24.0				22.8m/12.5	12.2	13.1	13.8		24.0
26.0					25.4m/10.5	11.2	11.9		26.0
28.0						28.0m/9.5	10.3		28.0
30.0							8.8		30.0
32.0							30.7m/8.4		32.0
Reeves	7	6	6	5	5	4	4	Reeves	

Working radius (m)	Boom length (m)				Boom length (m)	Working radius (m)
		36.6	39.6	42.7		
10.0	10.1m/37.5	10.8m/33.5	11.5m/29.4		10.0	
12.0	32.6	32.2	29.0		12.0	
14.0	27.3	27.1	27.0		14.0	
16.0	23.3	23.1	23.0		16.0	
18.0	20.3	20.1	19.9		18.0	
20.0	17.6	17.5	17.4		20.0	
22.0	15.4	15.3	15.2		22.0	
24.0	13.7	13.6	13.4		24.0	
26.0	12.2	12.1	12.0		26.0	
28.0	10.7	10.9	10.8		28.0	
30.0	9.4	9.8	9.7		30.0	
32.0	8.2	8.6	8.8		32.0	
34.0	33.3m/7.4	7.5	7.9		34.0	
36.0		36.0m/6.6	6.9		36.0	
38.0			6.2		38.0	
40.0			38.6m/5.9		40.0	
Reeves	4	3	3	Reeves		

Note:



Ratings according to Japanese Construction Codes for Mobile Cranes and Japanese Safety Ordinance on Cranes, etc.

Ratings shown in are determined by the strength of the boom or other structural components.

Lifting capacities may vary depending on hook used or with/without auxiliary sheave.

Please refer rated chart in operator's cabin.

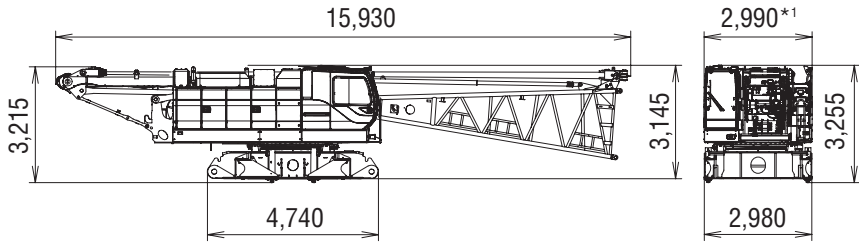
TRANSPORTATION PLAN

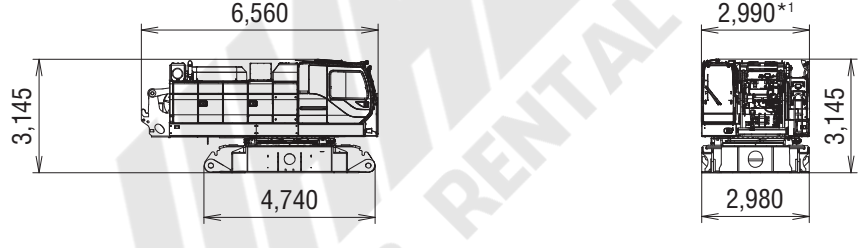
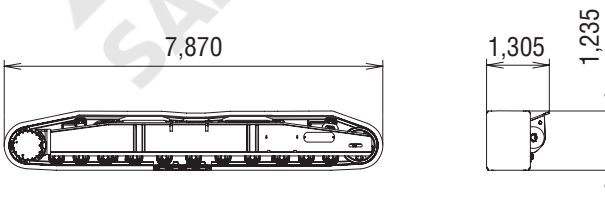
Name	Dimension (mm)	Weight (kg)
Base machine <ul style="list-style-type: none"> • Boom base • Gantry • Wire rope (Front / rear / boom hoist) • Crane backstop • Without crawler • Without side steps 		34,800
Base machine <ul style="list-style-type: none"> • Gantry • Wire rope (Front / rear / boom hoist) • Without crawler • Without self removal cylinder 		31,000
Base machine <ul style="list-style-type: none"> • Without crawler • Without gantry • Without wire rope (Boom hoist) • Without self removal cylinder • Without side steps 		25,400
Crawler		14,500

*1 With the side step on cabin side: 3,170
With the side steps on the both sides: 3,340

PARTS AND ATTACHMENTS

Base Machine

Boom base, Gantry, Wire rope (Front/rear/boom hoist)
Crane backstop, Without crawler, Without side steps
Weight: 34,800 kg Width: 2,990 mm*1

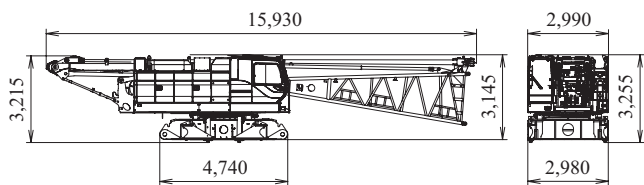

*1 With the side step on cabin side : 3,170
With the side steps on the both sides : 3,340

Crawler

Weight: 14,500 kg

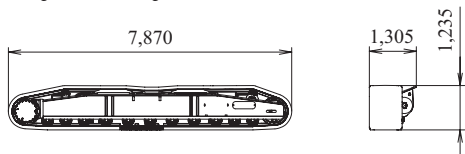

Gantry

Weight: 2,090 kg

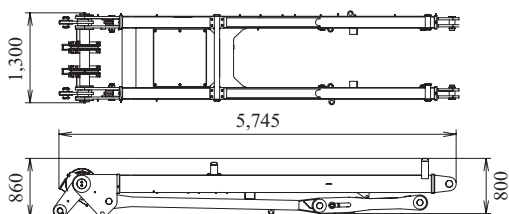

Boom Tip (for Crane)

Weight: 1,850 kg

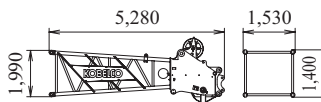

Boom Base (with Tower Backstop)

Weight: 3,100 kg

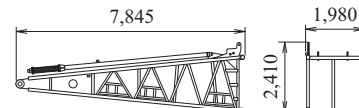

3.0 m Boom Insert

Weight: 530 kg

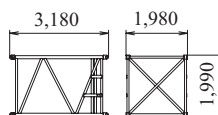

6.1 m Boom Insert

Weight: 850 kg

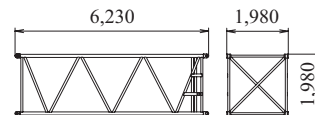

9.1 m Boom Insert

Weight: 1,160 kg

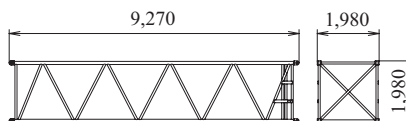

Taper Boom Insert

Weight: 490 kg

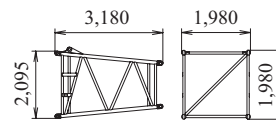

9.1m (9.1A) Special Boom Insert for Tower Boom (Inc. Guide Sheave and Steps)

Weight: 1,540 kg

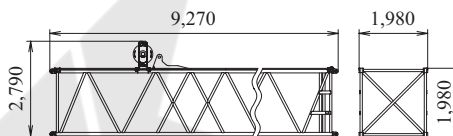

Jib Top (Fixed Jib)

Weight: 315 kg

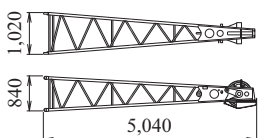

Jib Base (Fixed Jib)

Weight: 210 kg

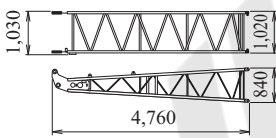

Tower Jib Top

Weight: 900 kg



Tower Jib Base

Weight: 1,200 kg

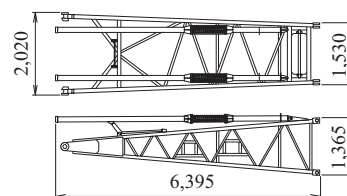

3.0 m Jib Insert (Tower Jib)

Weight: 210 kg

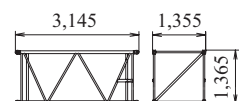

6.0 m Jib Insert (Tower Jib)

Weight: 360 kg

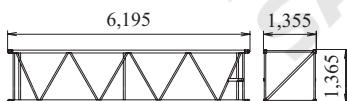

9.0 m Jib Insert (Tower Jib)

Weight: 510 kg

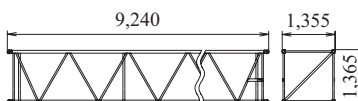

3.0 m (3.0A) Special Tower Jib Insert (Special Boom Insert)

Weight: 230 kg

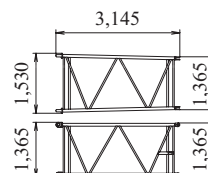

3.0 m Jib Insert (Fixed Jib)

Weight: 110 kg

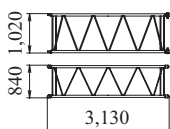

6.1 m Jib Insert (Fixed Jib)

Weight: 190 kg

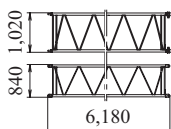

Jib Strut (Tower Jib)

Weight: 1,355 kg

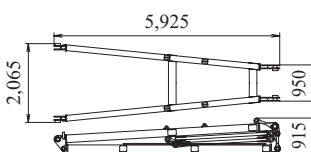

Crane Jib Strut

Weight: 300 kg

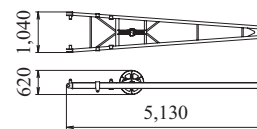

Tower Cap
Weight: 1,780 kg

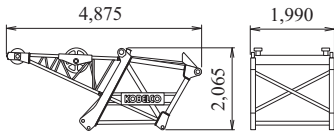

Crane Backstop
Weight: 210 kg / 1 piece

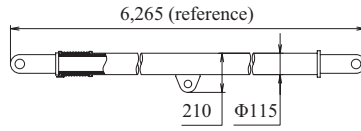

Backstop (for Tower)
Weight: 420 kg / 1 piece

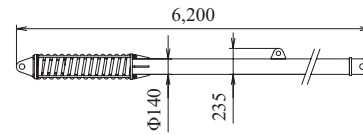

Upper Spreader (for Crane)
Weight: 485 kg

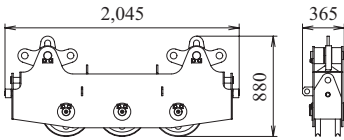

Lower Spreader (for Crane)
Weight: 315 kg

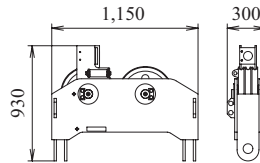

Upper Spreader (for Tower)
Weight: 310 kg

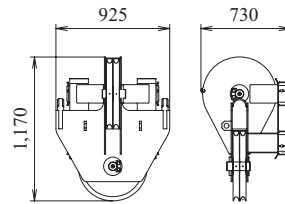

Lower Spreader (for Tower)
Weight: 410 kg

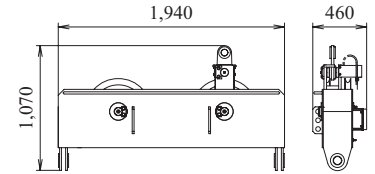

Counterweight (1)
Weight: 9,800 kg

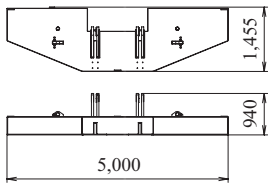

Counterweight (2)
Weight: 9,610 kg

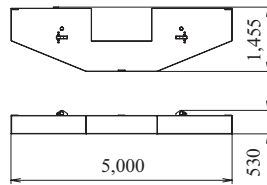

Counterweight (3)
Weight: 9,700 kg

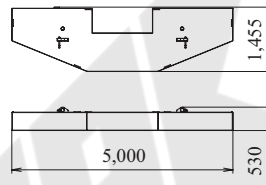

Counterweight (L)
(4) (6) (8) (4L) (5L) (6L)
Weight: 4,000 kg

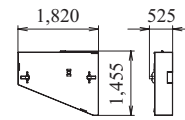

Counterweight (R)
(5) (7) (9) (4R) (5R) (6R)
Weight: 4,000 kg

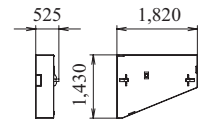

120 t Hook
Weight: 1,700 kg

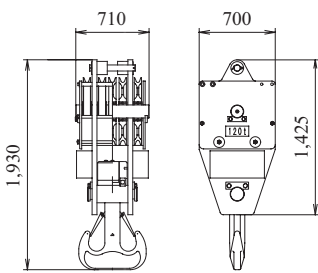

70 t Hook
Weight: 1,200 kg

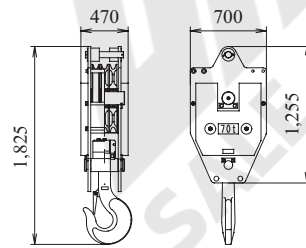

35 t Hook
Weight: 900 kg

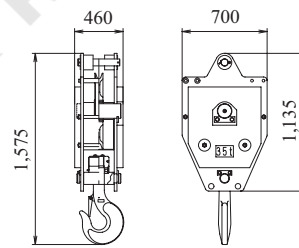

Ball Hook
Weight: 450 kg

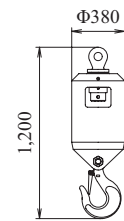

Translifter
Weight: 1,220 kg / 4 pieces

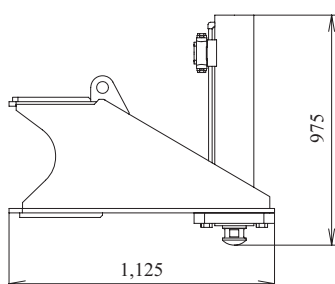

Note: Estimated weights may vary ± 2%.

WMAK
SALE & RENTAL

Note: This catalog may contain photographs of machines with specifications, attachments and optional equipment not certified for operation in your country. Please consult KOBELCO for those items you may require. Due to our policy of continual product improvements all designs and specifications are subject to change without advance notice.

Copyright by KOBELCO CRANES CO., LTD. No part of this catalog may be reproduced in any manner without notice.

KOBELCO CRANES CO., LTD.

17-1, Higashigotanda 2-chome, Shinagawa-ku, Tokyo 141-8626 JAPAN

Tel: +81-3-5789-2130 Fax: +81-3-5789-3372

URL: <http://www.kobelco-cranes.com/>

Inquiries To: