

# **KATO**

## **NK-1200**

**FULLY HYDRAULIC  
TRUCK CRANE**

Lifting Capacity **120t**



**KATO WORKS CO.,LTD.**



# NK-1200

## FULLY-HYDRAULIC FULL-SLEWING TRUCK CRANE

Maximum lifting capacity : 120tons

Maximum boom length : 70m(with jib)

### FIVE SECTION ZOOMMATIC® BOOM



#### FIVE SECTION ZOOMMATIC BOOM

- The NK-1200's rational boom controllable system (a sequential boom controllable system of extension and retraction and in which one lever operation controls the extension and the retraction of the boom ranging from 13.6 m to 50 m) prevents erroneous operation and provides safety and precise operation, irrespectively of the load variation.
- ACS moment limiter, of which KATO is proud, provides an appropriate total rating load and safety crane control at any boom length.
- The jib is easily attachable because the boom can be lowered to  $-2^{\circ}$ .
- The balanced design of the boom is highly durable because of the balanced super high tensile steel.

#### ROOSTER SHEAVE

- The rooster sheave mounted at the edge of the boom enables an easy single rope operation while housing the jib as it is, thus, enabling effective crane operation.

#### SUPERIOR RELIABLE ELECTRONICAL MOMENT LIMITER

- In conventional machines, crane operations depends upon experience of eye measurement and the intuition of the operator, but now the operations are controllable rational safety devices.
- Unique high accuracy of fully automatic overload protection device that prevents tipping and fracture of the crane.
- Most reliable moment limiter promotes an operator's self confidence and a feeling of a full command of his machine enabling him to operate the crane while confirming the safety work range as indicated on the moment comparator meter.
- Also, it is equipped with other highly accurate safety devices such as a boom length meter, boom angle indicator, and etc.
- The total moment, produced by a lifted load and a dead weight of the boom, is detected by the accurate detector. A buzzer alarm is sounded just as the total moment arrives at the 5% below the limit moment where a red lamp lights as it arrives at the limit moment thereby stopping the lowering of the boom, extension of the boom and the hoisting of the winch, automatically.



## FREE SPEED CHANGE FROM SUPER-LOW SPEED TO HIGH SPEED FINE SPEED CONTROL

### Powerful Freomatic Winch

- Smooth and continuous free high lifting operations as well as fine inching operations, using the levers and functioning of the flow controllable system, are achieved through the use of the super-low to high speed functioning of the powerful non-step controllable main and sub-winches.
- An automatic brake functions automatically, when a lever is returned to the neutral position. The free fall pedal significantly improves the operational efficiency, and the triple safety structure contains a counter balancing valve, automatic brake, drum lock device etc. that prevents danger and gives a precise safety operation.
- The grooved drum has an irregular winding prevention device that prevents irregular winding of the rope to lengthen rope life.

## SPLENDID MECHANISM OF WEIGHT DISTRIBUTION

- The ideal weight distribution and low center of gravity provide a superior operation and an excellent stability as well as excellent travelability and maneuverability.

## OPERATOR'S CONVENIENCES AND COMFORTABLE CAB

- Operator may enjoy his conveniences in the cab.
- One easy observable position of all levers and instruments.
- A heater is standard cab equipment and a cooler is optional.
- A deluxe soft fully reclinable seat that is re-adjustable to various positions to cause the operator no fatigue during extended periods of operation.
- Heat absorbent glass is glazed and clear to refract heat and to filter out the ultra-violet light which causes general fatigue. The glazed heat absorbent glass has a large water wiper blade adequately mounted to use in high lift operations during rainy inclement weather.
- The maximized glass portions are large so as to give the operator a necessary view of all surroundable areas.

## RAPID TRANSPORTATION IN AND OUT OF NARROW SITES

- The independently mounted engine enables a crane operation while traveling. Also, while traveling to and from a limited site, the jib can be mounted thereon.

## WIDE RANGE OF LIFTING CAPABILITY

Front Jack assures lifting operation in the range of 360°.

- The KATO CARRIER is provided with the Front Jack at its front frame as the standard equipment which enables the same lifting duty over 360 degrees.

## CONTINUOUSLY SMOOTH CRANE SLEWING

During a continuous crane slewing, the slewing mechanism remains stable all of the time.

- The crane's slewing is quite smooth because the slewing system contains an anti-shock brake valve in its mechanism.
- Smoothly fine slewing is obtained from the functioning of the cushion valve which weakens the shock that is generated during the starting and the stopping time.
- Abnormal shock that is generated by the counter lever operation is, also, prevented to assure safety operation.

## A TOUGH 254 PS DIESEL ENGINE

A tough 254 PS engine is exclusively used for the crane operation.

- An independently mounted tough and durable 254 PS diesel engine is, exclusively, used for the crane. It is separate from the carrier engine and preserves power during severe continuous operation of heavy loads and while high lifting as well as lifting of light loads that is done without any difficulty.

## STABLE OPERATION

Outriggers have high holding strength.

- The rugged box structure H-type hydraulic outriggers with long out stretched length and high holdable strength assures safety and stable operations.
- The long vertical cylinder stroke of the outriggers, in conjunction with the level vial, assures a horizontal settling of the crane at not only leveled land, but also non-leveled land such as sloped land or uneven land to cause a stable operation.





## SUPERSTRUCTURE SPECIFICATIONS

### CRANE PERFORMANCE

Rated lifting capacities: 120,000kg x 3.35m (13.6m boom)  
 50,000kg x 6.5m (20.4m boom)  
 40,000kg x 7.5m (27.2m boom)  
 32,000kg x 8.5m (34.0m boom)  
 26,000kg x 9.5m (40.9m boom)  
 20,000kg x 10.5m (45.5m boom)  
 15,000kg x 12.0m (50.0m boom)  
 7,500kg x 15.0m (50m boom + 11m Jib)  
 4,700kg x 18.0m (50m boom + 20m Jib)

### ENGINE

Maker: Mitsubishi Motors Corp.  
 Model: 8DC61C  
 Type: 4 cycle, water cooled, V type diesel engine  
 Maximum output: 254 ps/1950 rpm. (JIS)  
 Maximum torque: 97 kg-m/1200 rpm. (JIS)

### CRANE

Boom length: 13.6m~50m (5 section fullpower)  
 Jib length: 11m~20m (2 section)  
 Boom derricking angle:  $-2^{\circ} \sim 82^{\circ}$   
 \*Boom derricking time: 76sec. ( $0^{\circ} \sim 82^{\circ}$ )  
 \*Boom telescoping speed  
 Extension: 0.16m/sec. (from 13.6m boom  
 to 40.9m boom)  
 \*Hoisting and lowering line speed  
 (Main and auxiliary winches): (1st layer)  
 High 102m/min.  
 Low 51m/min.  
 \*Hoisting and lowering hook speed  
 Main winch (parts of line: 14): (1st layer)  
 High 7.2m/min.  
 Low 3.6m/min.  
 Auxiliary winch (parts of line: 1): High 102m/min.  
 Low 51m/min.  
 \*Slewing speed: 1.9r.p.m.

### WIRE ROPE FOR HOISTING

Main hoist: Type: 6 x Fi (29) I.W.R.C.  
 Diameter: 24mm $\phi$   
 Length: 265m  
 Auxiliary hoist: Type: 6 x Fi (29) I.W.R.C.  
 Diameter: 24mm $\phi$   
 Length: 150m

### HYDRAULIC SYSTEM

Hydraulic pump: 2 variable axial plunger type & 1 gear type.  
 Hoisting motor: Axial plunger type.  
 Slewing motor: Radial piston type.  
 Cylinder: Double acting type.  
 Control valve: 3 position 4 way double acting with  
 integral check, and relief valves.

Fluid reservoir capacity: 1250lit.

### CRANE CAB:

All steel welded construction.

### SAFETY DEVICES:

Outrigger lock device,  
 Boom derricking safety device,  
 Boom retracting safety device,  
 Over winding alarm device,  
 Boom angle indicator,  
 Hydraulic circuit safety valve (relief valve),  
 ACS (automatic crane stopper),  
 Drum turn indicator,  
 Drum lock device.

\*Speed: Subject to no load.

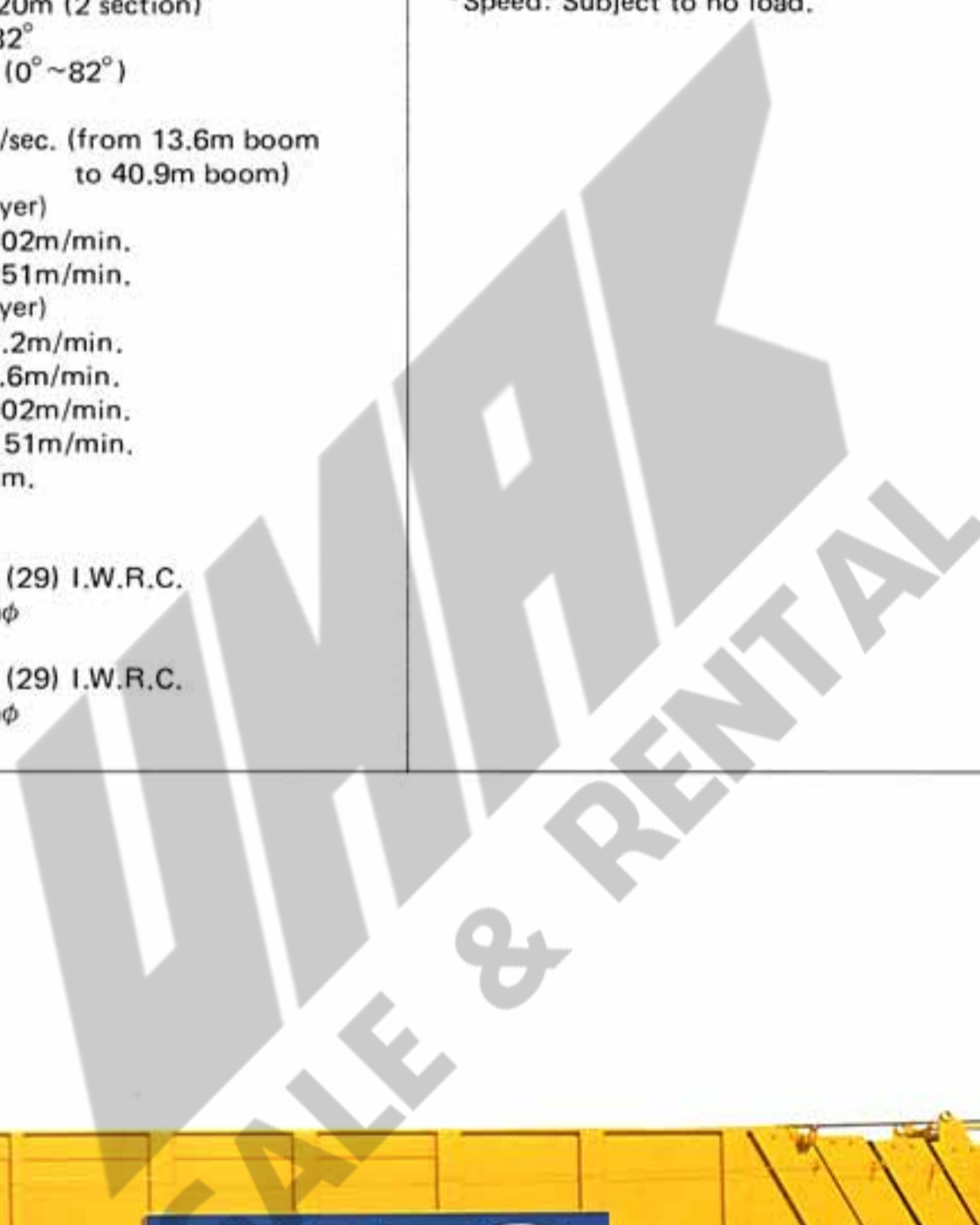



# CARRIER SPECIFICATIONS

## CARRIER

Model: KATO 6150  
 Drive system: 12 x 6  
 Maximum traveling speed: 65 km/h

## GENERAL DIMENSIONS

Overall length: approx. 16400mm  
 Overall width: approx. 3000mm  
 Overall height: approx. 4000mm  
 Wheel base: 6200mm  
 Treads: Front: 2540mm  
           Rear: 2156mm  
 Overall width outriggers extended  
 Center to center: 8000mm  
 Traveling weight: approx. 71,800kg  
 (without counterweight)

## ENGINE

Maker: Detroit Diesel Allison  
 Model: 8V-92TA  
 Type: 2 cycle, water cooled, V type diesel with turbocharger and aftercooler  
 Number of cylinder: 8  
 Bore x stroke: 123mm x 127mm  
 Piston displacement: 12.07lit.  
 Max. output horsepower: 435BHP/2100r.p.m.  
 Max. output torque: 171kg-m/1400r.p.m.  
 Clutch: 2 dry plate, hydraulic control with air booster  
 Transmission: 10 forward and 3 reverse  
 Axles: Front: Reverse "ELLIOT" type.  
           Rear: 1st: Reverse "ELLIOT" type  
               2nd, 3rd & 4th: Full floating type  
 Steering: Left hand steering with power booster  
 Suspension: Front: Leaf springs and torque rods  
               Rear: 1st: Hydropneumatic suspension  
                   2nd, 3rd & 4th: Underslung tridem walking beams and torque rods

## BRAKE

Service brake: 2 circuit air brake and air over hydraulic brake acting on all wheels,  
                   Front: Disc brake  
                   Rear: 1st Disc brake  
                       2nd, 3rd & 4th internal expanding type  
 Parking brake and Emergency brake: Variable air operated, spring loaded type, acting on 6 rear wheels  
 Electric system: 24V  
 Battery: 12V-150AHX2  
 Fuel tank capacity: 400lit.  
 Driver's cab: All steel welded construction, 2 persons, low line type  
 Tire size: Front: 14.00-24-24PR x 4  
               Rear (single tire): 14.00-24-24PR (1st) x 2  
               Rear (dual tire): 14.00-24-24PR (2nd, 3rd & 4th) x 12

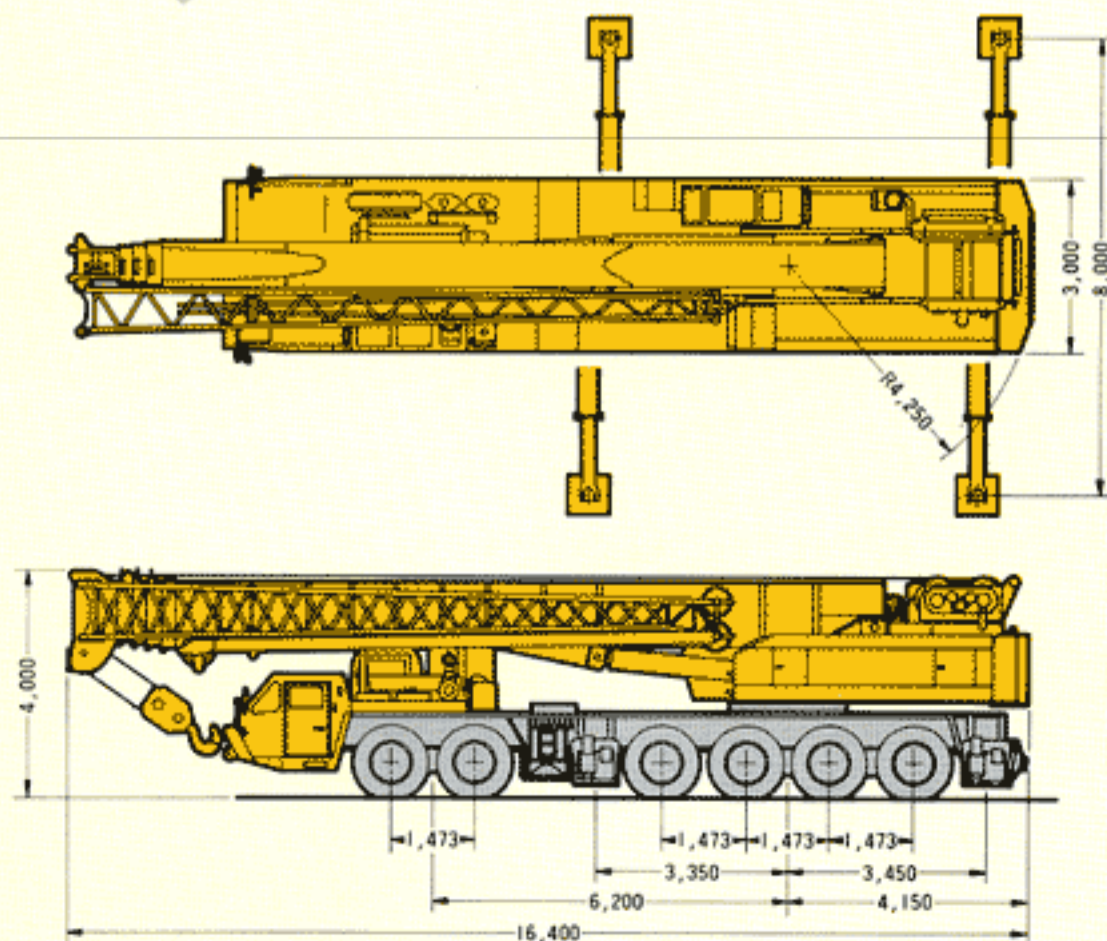



# WORKING RANGES

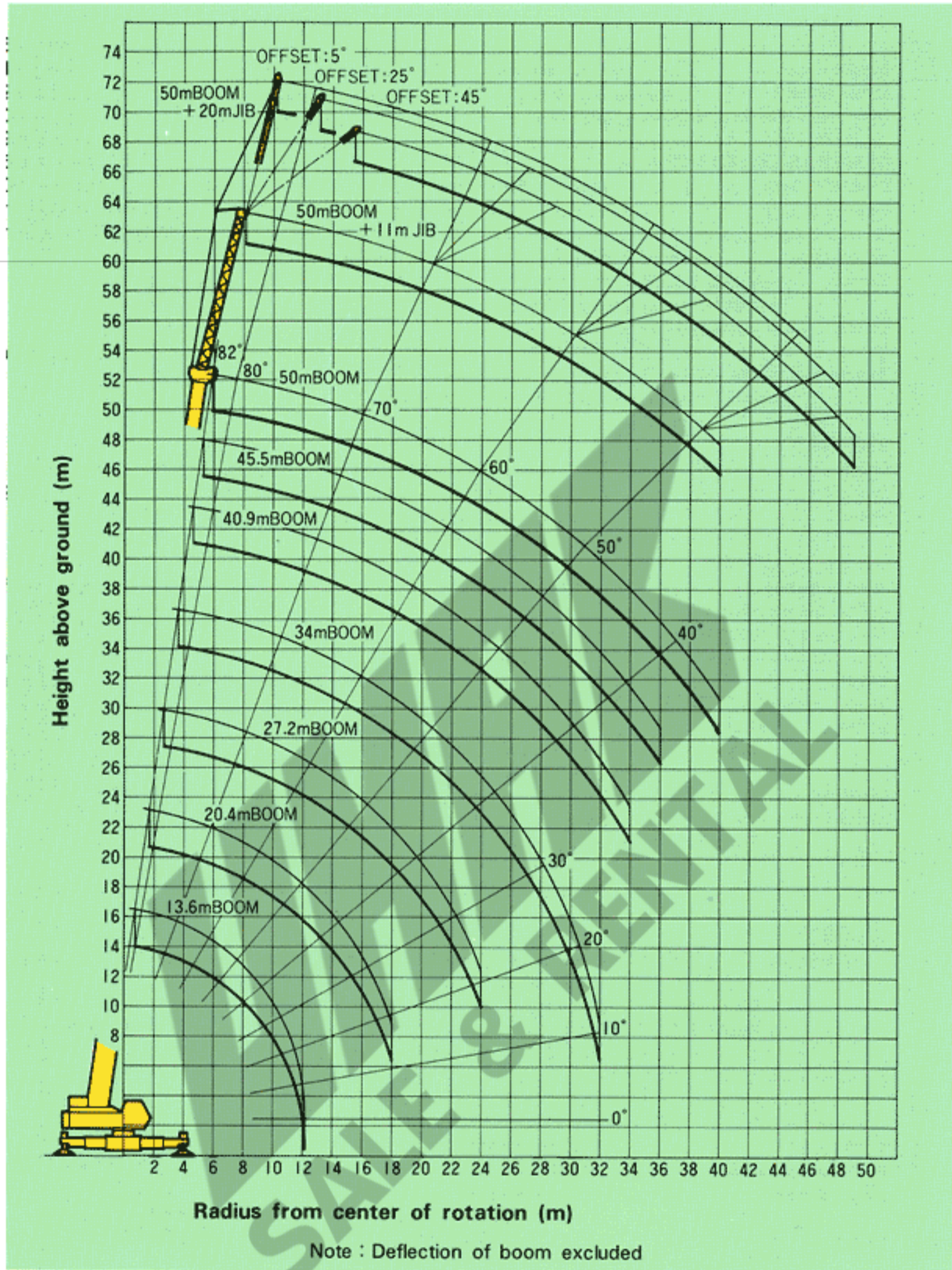



# RATED LIFTING CAPACITY (DIN 15019 Blatt2)

in metric ton

Working radius (m)	13.6m Boom		20.4m Boom		27.2m Boom		34.0m Boom		40.9m Boom		45.5m Boom		50m Boom	
	360°	Over rear	360°	Over rear	360°	Over rear	360°	Over rear	360°	Over rear	360°	Over rear	360°	Over rear
3.35	120.00	←	50.00	←	40.00	←								
4.0	100.00	←	50.00	←	40.00	←								
4.5	87.20	←	50.00	←	40.00	←	32.00	←						
5.5	72.30	←	50.00	←	40.00	←	32.00	←	26.00	←				
6.5	59.00	←	50.00	←	40.00	←	32.00	←	26.00	←	20.00	←		
7.5	49.40	←	44.05	←	40.00	←	32.00	←	26.00	←	20.00	←	15.00	←
8.5	42.50	←	39.15	←	35.60	←	32.00	←	26.00	←	20.00	←	15.00	←
9.5	37.50	←	35.80	←	32.05	←	28.75	←	26.00	←	20.00	←	15.00	←
10.0	35.30	←	34.25	←	30.50	←	27.35	←	24.55	←	20.00	←	15.00	←
10.5	32.85	←	32.85	←	29.05	←	26.05	←	23.25	←	20.00	←	15.00	←
11.0	31.30	←	31.30	←	27.75	←	24.95	←	22.00	←	19.25	←	15.00	←
12.0	26.60	27.10	26.60	27.10	25.40	←	22.95	←	19.90	←	17.60	←	15.00	←
13.0			22.70	23.45	22.70	23.45	21.15	←	18.30	←	16.30	←	13.80	←
14.0			19.50	20.40	19.50	20.40	19.50	←	17.00	←	15.10	←	12.80	←
15.0			17.05	17.95	17.05	17.95	17.05	17.95	15.80	←	14.10	←	11.95	←
16.0			14.90	15.80	14.90	15.80	14.90	15.80	14.75	←	13.27	←	11.15	←
18.0			11.55	12.45	11.55	12.45	11.55	12.45	11.55	12.45	11.75	←	9.90	←
20.0					9.05	9.90	9.05	9.90	9.05	9.90	9.85	10.50	8.80	←
22.0					7.10	7.90	7.10	7.90	7.10	7.90	7.90	8.65	7.90	←
24.0					5.55	6.30	5.55	6.30	5.55	6.30	6.30	7.05	7.05	7.20
26.0							4.25	5.00	4.25	5.00	5.00	5.70	5.70	6.40
28.0							3.20	3.90	3.20	3.90	3.95	4.60	4.60	5.25
30.0							2.30	2.95	2.30	2.95	3.00	3.65	3.70	4.30
32.0							1.50	2.15	1.50	2.15	2.20	2.85	2.90	3.50
34.0									0.85	1.45	1.55	2.15	2.20	2.75
36.0											1.00	1.55	1.60	2.15
38.0													1.05	1.60
40.0													0.60	1.10
Standard hook	for 120 tons						for 50 tons						for 15 tons	
Hook weight	1,050kg						600kg						330kg	
Parts of line	14		6		5		4		3		3		2	
Min. boom angle									15°		30°		35°	

- When the boom length exceeds the specified value, the rated lifting capacities for the boom lengths adjacent to the present boom length should be referred to, and the crane should be operated with the smaller lifting capacity. Especially for 13.6m boom, operate the crane with the rated lifting capacities for 20.4m boom except when the boom is fully retracted.
- For a working radius between the main specified values, refer to the larger working radius, or the smaller load. For a boom angle for jib operation between the main specified values, similarly refer to the lower angle, or the smaller load.
- When using the boom with the jib installed 3.900kg should be subtracted from rated lifting capacities besides the weight of the hoisting equipment, etc.

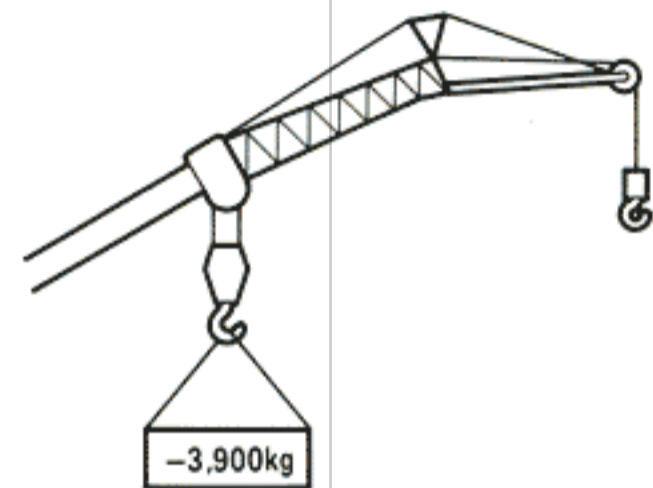

- "360°" in the table means lifting over the entire circumference, and "over rear" does lifting over rear within a zone of 60°.
- Lifting over front (a zone of 150° in front of the carrier) is not permitted if front jack is not used.

Radius in meter, load in metric ton

Boom angle (°)	50m Boom + 11m Jib (5°)				50m Boom + 20m Jib (5°)				50m Boom + 20m Jib (25°)				50m Boom + 20m Jib (45°)			
	360°		Over rear		360°		Over rear		360°		Over rear		360°		Over rear	
	Working radius	Load	Working radius	Load	Working radius	Load	Working radius	Load	Working radius	Load	Working radius	Load	Working radius	Load	Working radius	Load
79°	15.0	7.50	←	←	18.0	4.70	←	←	20.5	3.40	←	←	22.2	2.30	←	←
77.5°	16.6	7.05	←	←	19.6	4.45	←	←	22.3	3.30	←	←	24.0	2.30	←	←
76°	18.2	6.55	←	←	21.6	4.15	←	←	24.0	3.05	←	←	25.7	2.25	←	←
74°	20.2	5.90	←	←	23.9	3.75	←	←	26.3	2.80	←	←	27.8	2.20	←	←
72°	22.1	5.30	←	←	26.0	3.40	←	←	28.5	2.60	←	←	30.0	2.15	←	←
70°	24.0	4.80	←	←	28.2	3.05	←	←	30.7	2.40	←	←	32.2	2.10	←	←
68°	26.0	4.40	←	←	30.5	2.75	←	←	32.9	2.20	←	←	34.3	2.05	←	←
66°	28.0	4.05	←	←	32.8	2.50	←	←	35.1	2.05	←	←	36.5	1.90	←	←
64°	29.9	3.75	←	←	34.9	2.30	←	←	37.2	1.90	←	←	38.4	1.80	←	←
62°	32.1	3.40	32.1	3.50	37.0	2.10	←	←	39.1	1.80	←	←	40.1	1.70	←	←
60°	33.4	2.75	33.4	3.35	39.0	1.95	←	←	41.1	1.70	←	←	42.0	1.60	←	←
58°	35.0	2.20	35.1	2.75	41.0	1.75	41.0	1.80	43.0	1.60	←	←	43.9	1.50	←	←
56°	36.6	1.75	36.8	2.20	43.0	1.35	43.0	1.65	44.8	1.30	44.8	1.50	45.8	1.35	45.8	1.40
54°	38.0	1.35	38.3	1.80	44.8	1.00	44.9	1.45	46.5	1.00	46.6	1.40	47.5	1.05	47.5	1.35
52°	39.5	0.95	39.8	1.40	46.4	0.70	46.6	1.10	48.1	0.80	48.3	1.20	49.0	0.75	49.0	1.20
50°	41.0	0.65	41.3	1.10												
Use hook	for 7.5 tons (weight : 320kg)															
Min. boom angle	48°				50°				50°				50°			

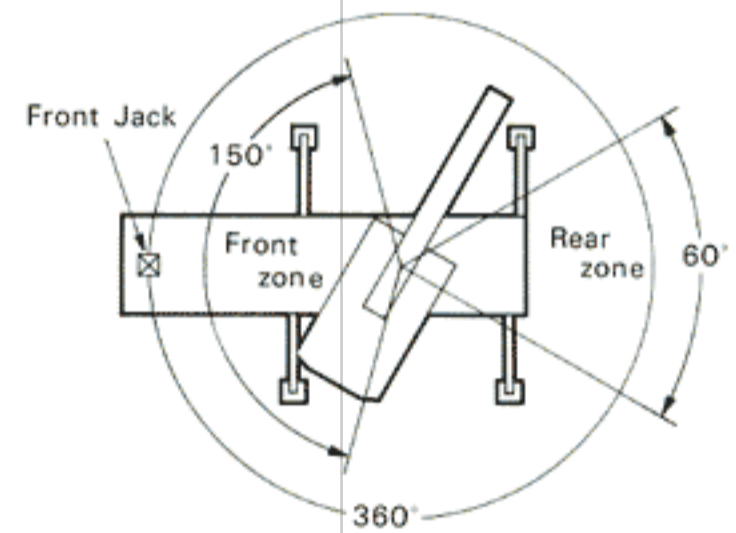

## [NOTE]

- The rated lifting capacities are the maximum loads guaranteed on a firm level ground when the outriggers, front jack and axle lock are set properly.
- The rated lifting capacities include the weight of hook block and other lifting equipment. The capacities in the blue area are based on the structural strength.
- The working radii given in the table for main boom operation are the actual values including the deflection of the booms. Therefore operate the crane based on the working radius.
- The working radii given in the table for jib operation indicate the values when operating 50m boom with jib mounted on it, and the crane should be operated based on the working radii. For other boom lengths, carry out jib operation based on boom angle alone.
- The arrows in the tables indicate that "load" for lifting over rear is the same as that for 360°.
- Do not lower the boom below the min. boom angle for each boom length. Otherwise the machine might tip over even without load. When the boom length exceeds the specified value, do not lower the boom below the min. boom angle for the next longer boom.
- The number of parts of line optimum for the hook is determined according to lifting load, winch capacity, rope length, etc. Standard hook and parts of line for each boom length are shown in the table.
- The rated lifting capacities for the rooster sheave are equal to those of the main boom, but the maximum rated lifting capacity is 7,500kg, which includes the weight of hook blocks for the rooster sheave operation and main boom operation.
- The crane will tip-over or be damaged if operated with a load other than specified in the rated lifting capacity table or not conforming to correct handling.





Address inquiries to:

• NOTE: Illustrations may include optional equipment. KATO products and specifications are subject to improvements and changes without notice.



## **KATO WORKS CO.,LTD.**

9-37, Higashi-ohi 1-chome, Shinagawa-ku, Tokyo 140, Japan

Tel : Head Office Tokyo (03) 3458-1111

Overseas Marketing Department Tokyo (03)3458-1115

Telex : 0222-4519 (CRKATO J)

Fax : Tokyo (03)3458-1152

Cable : CRANEKATO TOKYO